

Demonstration of Long-Reach PON Using 10Gb/s 3R Burst-Mode Wavelength Converter for Metro-Access Convergence

Nguyen-Cac Tran, *Student Member, IEEE*, Johan Bauwelinck, *Member, IEEE*, Xin Yin, *Member, IEEE*, Eduward Tangdiongga, *Member, IEEE*, and Ton Koonen, *Fellow, IEEE*

Abstract—Long-reach optical access networks promise significant cost savings. To merge existing metro and access networks to a single long-reach network, the long-reach technology have to address not only the power loss and fiber dispersion problems but also the incomparability between two merged entities in terms of wavelengths and operational modes, especially during the transition period. In this paper, we demonstrate a long reach network employing 10 Gb/s burst-mode O/E/O wavelength converter. The converter can simultaneously address the power loss, dispersion, and incomparability problems by a compact assembly. Two upstream wavelengths located in the 1310 nm and 1550 nm windows in the access section are converted to a DWDM wavelength of 1554.13 nm in the metro section. The error-free performance is achieved with a loud/soft ratio of 10 dB at a sensitivity of -27 dBm and the overhead for the burst-mode operation is as low as 0.512%.

Index Terms—Wavelength division multiplexing; Optical wavelength conversion; Optical fiber communication.

I. INTRODUCTION

HIGH-SPEED optical access networks have become a key infrastructure in the modern society and economy since they can deliver large bandwidth with low cost in a much longer distance in respect to other technologies. Passive optical access networks (PON) can typically reach up to 20 km between the optical line terminal (OLT) in the central office (CO) and the optical network unit (ONU) in the customer premise. The network reach beyond 20 km has been widely studied since long-reach networks promise significant operational expenditure (OPEX) savings by network consolidation [1]. In fact, the reach of 60 km was already considered as an option for gigabit-capable PON (GPON),

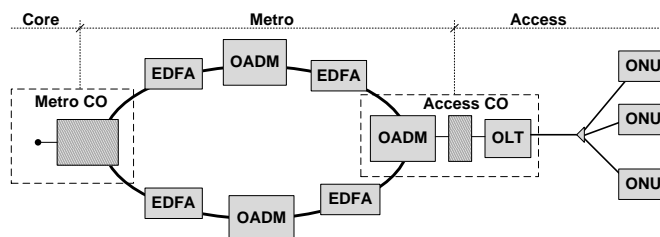

Fig. 1. Typical configuration of metro and access networks in which OADMs and EDFAs are used in the metro network.

which is the most widely-deployed PON standard [2]. Using the reach of 60 km, the network of Deutsche Telekom, the German telecom incumbent, can be consolidated into 900 COs from around 8000 COs based on a survey reported in [3]. To cover more deployment scenarios, the reach of up to 100 km is typically referred to as the long-reach distance.

The main constraint for long-reach is the optical power loss which is contributed by the split losses and fiber attenuation. To compensate the additional fiber attenuation in long-reach while maintaining a cost-effective split ratio (1:32 or 1:64), an optical amplifier, also known as the extender box, can be placed in the mid-span [4]. The amplifier should be able to handle the burst-mode optical signal in the upstream since the burst from the near ONU can be stronger by several orders of magnitude than that from the far ONU. In addition to the optical power constraint, fiber dispersion also becomes significant because of long transmission distance. The more stringent quality transceivers (TRx) should be used in association with a dispersion compensation technique such as using a negative dispersion fiber for dispersion mitigation. As an alternative, the optical/electronic/optical (O/E/O) solution for the extender box was also investigated since it can provide 3R (re-amplifying, re-shaping, and re-timing) to the optical signal [5][6][7][8]. The 3R solution can solve both the power budget and dispersion problem at one point which promises cost-effectiveness.

There are also other practical difficulties for long-reach PON deployments. In many scenarios, long-reach PONs are the result of merging existing metro and access networks. Figure 1 shows a typical configuration of metro and access networks in which the current access OLT interfaces to the metro network through electrical L2 or L3 (Layer 2/3)

Manuscript received Feb. 18, 2013. This work was supported in part by the EU FP7 ALPHA and EURO-FOS projects.

Nguyen-Cac Tran, Eduward Tangdiongga and Ton Koonen are with the COBRA Institute, Eindhoven University of Technology, NL-5600MB Eindhoven, The Netherlands (e-mail: c.tran.nguyen@tue.nl; E.Tangdiongga@tue.nl; a.m.j.koonen@tue.nl).

Johan Bauwelinck and Xin Yin are with INTEC/IMEC, Ghent University, Sint-Pietersnieuwstraat 41, B-9000, Ghent, Belgium (email: johan.bauwelinck@intec.ugent.be, xin.yin@intec.ugent.be)

Copyright (c) 2011 IEEE. Personal use of this material is permitted. However, permission to use this material for any other purposes must be obtained from the IEEE by sending a request to pubs-permissions@ieee.org

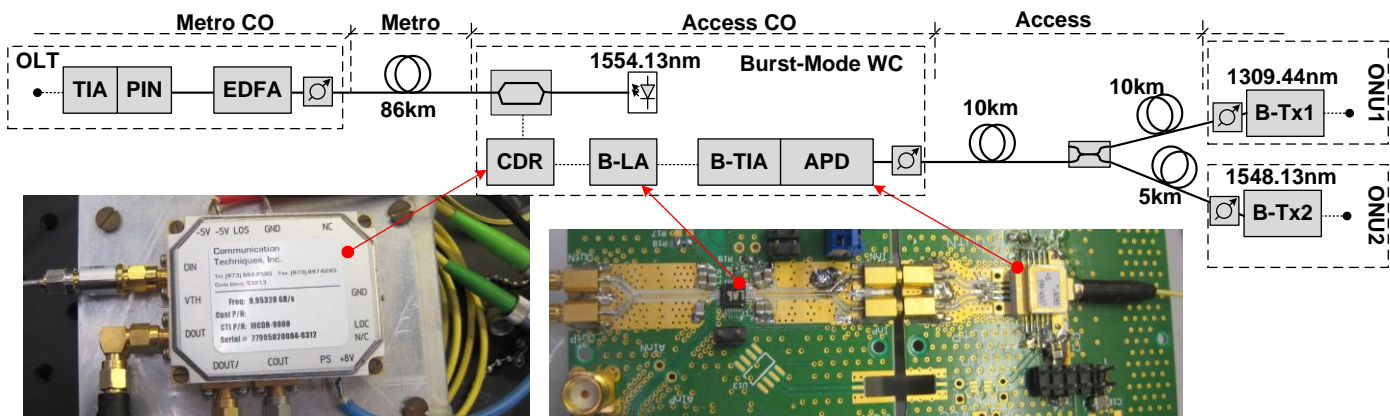

Fig. 2. Experimental setup for metro/access convergence using 3R wavelength converter

switches and optical metro transport equipments illustrated as shaded boxes. To consolidate COs, the long-reach OLT is moved deeper into the metro CO leaving the access CO with only small footprint, low-power-consumption, and low-maintenance equipments. However, the metro network is usually designed for the signal in continuous and synchronous mode using SONET/SDH standards. Furthermore, metro wavelengths are located in the C band covering 1528 nm to 1563 nm since it is the operational window of metro equipments such as erbium-doped fiber amplifiers (EDFAs) and optical add/drop multiplexers (OADMs) while the access network uses different windows, e.g. 1310 nm for the upstream [9]. Thus, merging the two incompatible networks are not a straightforward process, especially during the long transition period when the metro network still has to serve other legacy services. Wavelength conversion methods have been investigated to address the incompatibility problem. Demonstrations for optically converting the burst-mode upstream signal at 2.5 Gb/s have been reported in [10] and [11]. These demonstrations employed semiconductor optical amplifiers (SOAs) to equalize the burst power and optically convert to a dense wavelength division multiplexing (DWDM) wavelength by using cross gain modulation. These techniques can be considered as an 1R (re-amplifying) solution with signal power equalization.

In this paper, we present a demonstration of burst-mode wavelength conversion using 3R O/E/O converter at 10 Gb/s. The 3R converter can provide a 3-in-1 solution by re-amplifying to address the power loss, re-shaping at a new wavelength to address the metro/access incompatibility problem, and re-timing to address the fiber dispersion. The demonstration shows a low overhead for burst-mode data recovery without any timing knowledge from the medium access control (MAC) layer.

II. EXPERIMENTAL SETUP

The experimental setup is shown in Fig. 2 in which two ONUs send upstream bursts alternatively towards the OLT at 9.95328 Gb/s. This bit-rate is determined by the operational bit-rate of the clock and data recovery (CDR) module in the

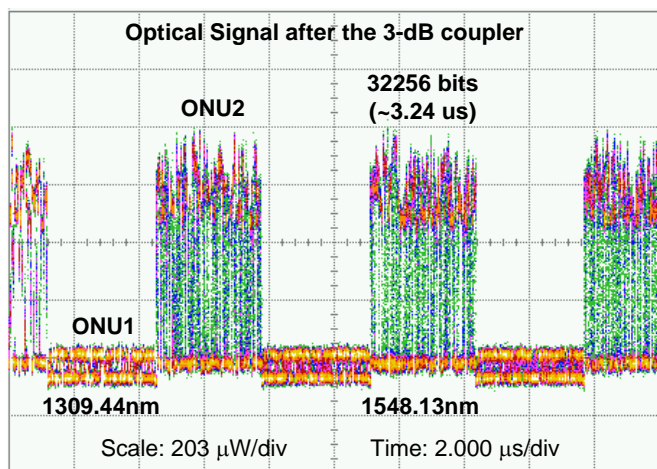

Fig. 3. Time trace of the optical signal with loud and soft packets after the 3-dB coupler

wavelength converter. Both ONUs employ integrated EML (Electro-absorption modulated laser) as the burst-mode transmitter. *ONU1* and *ONU2* transmit the signal at 1309.44 nm and 1548.13 nm, respectively at room temperature. The large wavelength distance between ONU's wavelengths was selected in order to demonstrate the wide operational window of the converter.

The signal from *ONU1* reaches the 3dB coupler after 10km standard single mode fiber (SMF-28) while a 5km of SMF-28 is placed between *ONU2* and the coupler. Optical bursts from both ONUs after the coupler are shown in Fig. 3. The loud/soft ratio between strong bursts from *ONU2* and weak bursts from *ONU1* is adjusted to be 10dB by variable optical attenuators in front of the ONU transmitters. This ratio can account for more than 20km differential distance between the near and far ONUs. Each burst is 32256 bits long composed of two parts. The preamble of 768 alternating 0 and 1 bits and the payload of 31488 bits derived from pseudo-random binary sequence (PRBS) $2^{31}-1$. The guard time between two consecutive bursts measured at the transmitter output is 53.7ns equivalent to 512 bits.

After the coupler, bursts travel through another 10km of SMF-28 to reach the 3R burst-mode wavelength converters.

The wavelength converter is composed of 4 stages in which the burst-mode optical signal is converted to the electrical domain by DC-coupled integrated burst-mode receiver (B-Rx) in the first stage. The burst-mode receiver employs an avalanche photodiode (APD) to detect the optical signal. The circuitry after the APD is able to detect the burst power and reset the gain internally to handle large variations in burst. Generating the reset signal internally eliminates the need of the MAC layer that greatly simplifies the wavelength converter. The MAC layer module is typically required to generate the external gain reset signal based on timing allocations if the B-RX is not capable of detecting the burst power and resetting gain by itself. The B-Rx is also integrated with burst-mode transimpedance amplifier (B-TIA). The detail design and operation of the B-Rx can be found in [12]. After the B-TIA, the signal is dc-coupled to the burst-mode limiting amplifier (B-LA) in the second stage to fully equalize the bursts. After equalization, the signal is ac-coupled to a commercial CDR for re-timing in the third stage. Finally, the “clean” signal is converted back to the optical domain by a LiNbO₃ external modulator. The continuous-wave wavelength fed to the external modulator is provided by a DWDM DFB laser working at 1554.13 nm.

The signal travels through 83km of SMF-28 to reach the final destination in which it is amplified by a conventional EDFA pre-amp before entering the PIN photodiode.

III. RESULTS AND DISCUSSIONS

The time traces after the first, the second, and the third stage of the wavelength converter are shown in Fig. 4. These traces focus on the transition period between the strong burst from *ONU2* and the soft burst from *ONU1*. The alternating 0 and 1 preamble sequence assists the B-RX, the B-LA, and the CDR in their operation against burst-mode signal. The alternating 0 and 1 pattern is used to maximize the number of level transitions. In each stage, the preamble is shortened because the lost portion is used to adjust the module operating parameters to the new burst. The lost portion after the B-TIA is used to reset the gain according the burst power while the lost part after the B-LA is used to obtain the correct decision threshold. The lost portion after the CDR is used to synchronize the clock signal. After three stages, the remaining preamble is 585 bits meaning that 183 bits are lost which is equivalent to 18.4 ns. Therefore, 20 ns preamble can provide adequate margin for the operation of the wavelength converter. This small preamble results in only 0.512% overhead in a GPON-like network (125 μ s transmission round) with 32 ONUs.

After the CDR, the signal is completely re-shaped and re-timed to prepare for a long transmission distance. At this point, a high quality modulator is used to convert the signal back to the optical domain. The metro wavelength can be fully controlled by the CW wavelength, thus any available metro wavelength can be used. The LiNbO₃ modulator can provide the modulated signal with a high signal-to-noise (SNR) ratio

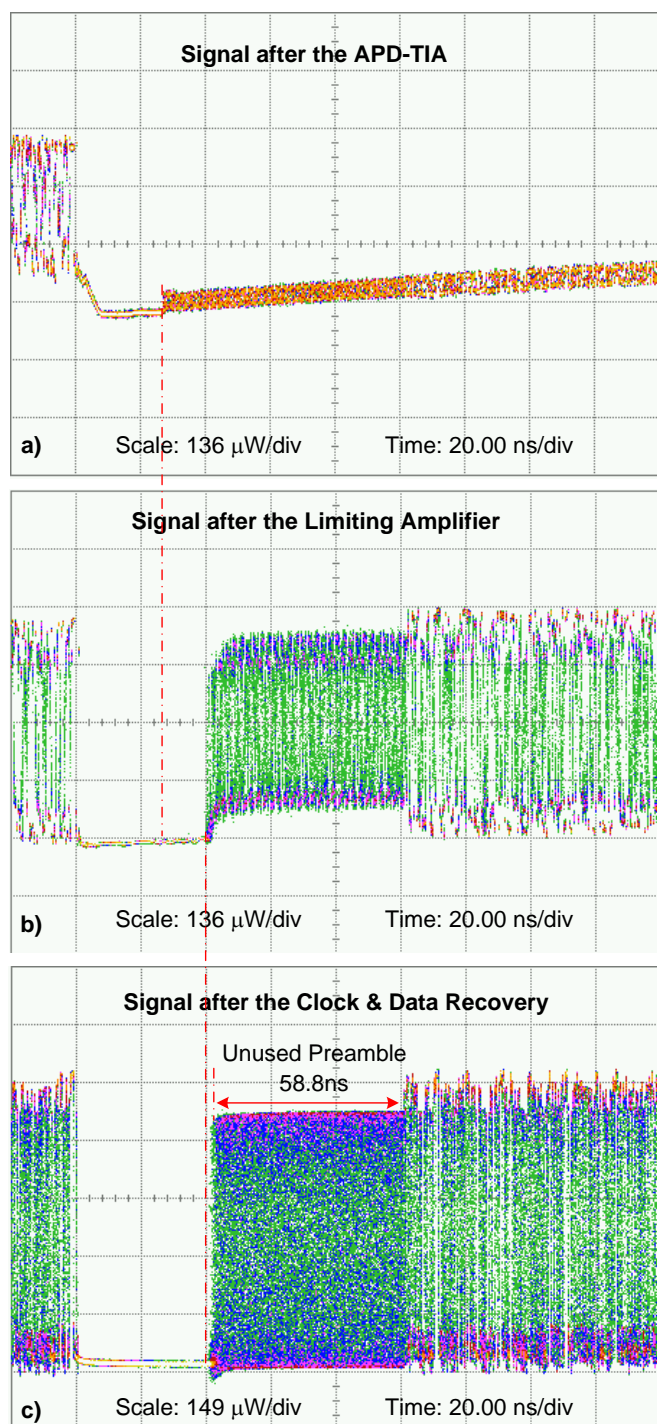

Fig. 4. Time trace of electrical signals within the burst-mode wavelength converter, a) after the burst-mode APD-TIA chip (measured via AC-coupling), b) after LA chip, c) after CDR module

and a low jitter which can survive 86 km transmission without any dispersion compensation technique. The bit error rate (BER) performance shown in Fig. 5 confirmed this fact. The system achieves error-free operation when the average received optical power is higher than -29 dBm. The received optical power is measured in front of the pre-amp EDFA. The BER from both *ONU1* and *ONU2* bursts are almost identical due to the fact that these bursts are completely 3R in the wavelength converter. The back-to-back case, when all SMF-

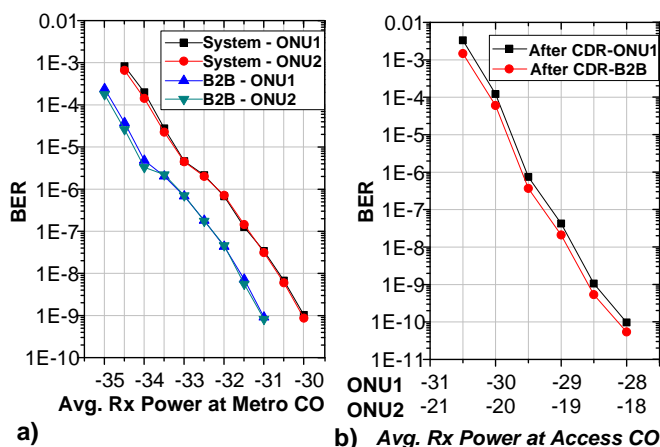

Fig. 5. Bit error rate performance, a) at the metro CO, b) at the access CO

28 fibers are removed, is also shown in Fig.5.a). The power penalty is around 1 dB which is mainly contributed by dispersion in the 86 km transmission. In this system BER measurement, the average received optical power at the input of the wavelength converter is fixed to be -17 dBm to guarantee error-free operation in the access section. This received power level is mainly determined by the strong bursts from *ONU2* since the soft bursts from *ONU1* are 10 dB weaker.

The detail BER performance in the access section (after the CDR) is shown in Fig. 5.b) in which only the BER of the soft bursts from *ONU1* can be observed (as the bursts from *ONU2* are 10 dB stronger and consequently error-free). When the received optical power from *ONU1* is higher than -27 dBm, the error-free operation is achieved on both ONUs. At this level, the power from *ONU2* is -17 dBm which is well within the dynamic range of the B-Rx. The power penalty in comparison to the back-to-back case when SMF-28 fibers are removed is less than 0.5 dB that means the fiber dispersion in this section is not significant. The Rx sensitivity of -27 dBm and the launch power of 3 dBm allows 30 dB loss in the access section that results in up to 1:128 split ratio and 20km reach with adequate margin.

The pre-amp EDFA used in the metro section is not only to increase the Rx sensitivity but also to demonstrate that a continuous-mode EDFA operates properly in this configuration. The power of bursts is completely equalized after the wavelength converter as indicated in Fig. 4.c). The power void period occurring during the guard time between two bursts may create a transient effect in the EDFA if it is too long. However, the guard time of 512 bits used in this experiment, which is much longer than the recommended 64 bits in ITU-T. G.987.3, created no transient effect in the EDFA. In the case that the metro section can only tolerate a shorter void period, a gap filling technique by inserting dummy bits should be used in the wavelength converter, which is similar to the technique demonstrated in [13].

IV. CONCLUSION

This paper demonstrated for the first time a 10 Gb/s 3R wavelength conversion technique which can be employed in 10G-EPON-based and XG-PON-based long-reach access networks. The technique aims to facilitate a smooth transition in metro and access convergence. The demonstrated wavelength converter is ready to be compactly assembled in a line card. The converter was able to handle 10 dB loud/soft ratio with only a 20 ns overhead for each burst. The O/E/O technique can address both the fiber dispersion and wavelength conversion at the same time in the expense of less signal transparency in comparison to an all-optical wavelength conversion technique. However, the O/E/O wavelength conversion is considered to be more reliable and mature than the all-optical counterpart. Furthermore, the capability to handle bursts in the bit level without support from the MAC layer allows the 3R converter to remain protocol independent.

REFERENCES

- [1] R.P. Davey et al., "Long-Reach Passive Optical Networks," *J. Lightw. Technol.*, vol. 27, no. 3, pp. 273–291, Feb. 2009.
- [2] "Gigabit-capable passive optical networks (GPON): Long reach." ITU-T Recommendation G.984.7, Jul-2010.
- [3] M. Fricke, "Examining the Evolution of the Access Network Topology," in *Proc. of Global Telecom. Conf. (GLOBECOM 2009)*, 2009, pp. 1–3.
- [4] K.-I. Suzuki, Y. Fukada, D. Nettet, and R. Davey, "Amplified gigabit PON systems [Invited]," *J. of Opt. Netw.*, vol. 6, no. 5, pp. 422–433, May 2007.
- [5] R.P. Davey et al., "DWDM reach extension of a GPON to 135 km," *J. Lightw. Technol.*, vol. 24, no. 1, pp. 29–31, Jan. 2006.
- [6] K.-O. Kim, K.-H. Doo, and S.-S. Lee, "Implementation of OEO based reach extender for 60km long reach GPON," in *Proc. of 9th Int. Conf. on Opt. Internet (COIN2010)*, 2010, pp. 1–3.
- [7] J. Park, G. Y. Kim, H. J. Park, and J. H. Kim, "FTTH Deployment Status & Strategy in Korea: GW-PON Based FTTH Field Trial and Reach Extension Strategy of FTTH in Korea," in *Proc. of Global Telecom. Conf. (GLOBECOM 2008)*, 2008, pp. 1–3.
- [8] Noriyuki Miyazaki, Keiji Tanaka, and Yukio Horiuchi, "Hybrid TDM-WDM EPON Repeater," in *Proc. of Opt. Fiber Commun. Conf. and Expo. and the National Fiber Opt. Engineers Conf. (OFC/NFOEC 2008)*, 2008, p. NMD2.
- [9] T. Pfeiffer, "Converged heterogeneous optical metro-access networks," in *Proc. of 36th European Conf. and Exhibit. on Opt. Commun. (ECOC2010)*, 2010, p. Tu.5.B.1.
- [10] D.P. Shea, and J.E. Mitchell, "Architecture to integrate multiple PONs with long reach DWDM backhaul," *J. on Sel. Areas in Commun.*, vol. 27, no. 2, pp. 126–133, Feb. 2009.
- [11] B. Cao, J.M.D. Mendinueta, B.C. Thomsen, and J.E. Mitchell, "Demonstration of a 10 Gbit/s Long Reach Wavelength Converting Optical Access Network," *J. Lightw. Technol.*, vol. 31, no. 2, pp. 328–333, Jan. 2013.
- [12] Xin Yin et al., "Experiments on a 10 Gb/s fast-settling high-sensitivity burst-mode receiver with on-chip auto-reset for 10G-GPONs [Invited]," *J. Opt. Commun. Netw.*, vol. 6, no. 11, pp. B68–B76, Nov. 2012.
- [13] F. Saliou, P. Chanclou, B. Landousies, N. Genay, and C. Le Bouette, "Extended reach access network based on aggregation of the G-PON traffic," in *Proc. of Opt. Fiber Commun. Conf. and Expo. and the National Fiber Opt. Engineers Conf. (OFC/NFOEC 2009)*, 2009, p. NThC2.