

DENTAL IMPLANTS, WHAT SHOULD BE KNOWN BEFORE STARTING AN *IN VITRO* STUDY

K. Verplancke¹, W. De Waele² and H. De Bruyn³

¹ Ghent University, Belgium

² Ghent University, Laboratory Soete, Belgium

³ Ghent University, Periodontology & Oral Implantology, Belgium

Abstract Dental implant–abutment systems are used as anchors to support single or multi-unit prostheses for partially or fully edentulous patients. *In vitro* experiments and finite element analyses can be used to investigate their mechanical performance. Accurate information is needed on the geometry, material properties and friction coefficients of different implant-abutment components, on real loading conditions, and elastic properties of human jawbone. Information can be retrieved from previously reported studies or experiments. This paper provides a summary of a small but representative part hereof. Research has shown that the elastic properties of human jawbone are direction dependent and that the Young's modulus (E) also depends on the bone type. Other studies investigated the maximum bite forces and reported a broad range of results, from 200 to 2000 N. Static experiments are typically performed with axial or bending loads to evaluate the performance of dental implant systems. Dynamic tests simulate chewing cycles and are used to evaluate the fatigue endurance. The supporting structure of the implant system should be representative for the bone structure. Finite element models are ideally suited to evaluate the biomechanical behaviour of implant systems. Accurate representation of the supporting bone and its interaction with the implant is crucial.

Keywords dental implants, *in vitro* experiments, human bite force, elastic properties

1 INTRODUCTION

Dental implant–abutment systems are used as anchors to support single or multi-unit prostheses for partially or fully edentulous patients. If a fixed partial denture (FPD) on implants is to be constructed in the premolar and/or molar region, where the implants stand approximately on a straight line, it is advisable to select an implant system with high strength values. Implant systems with lower values would suffice if a full arch fixed prosthesis (for fully edentulous patients) is planned. In the latter situation, the implants are approximately placed in a horseshoe formation, which favours strength and stability. A dental implant system consists of an implant that is surgically implanted in maxilla (upper jawbone) or mandible (lower jawbone), and an abutment that mates with the implant. In the 2-stage protocol the placement of the abutment happens once the implant successfully osseointegrates to the bone. This is after a 3 to 4 months submerged healing period. In the immediate loading protocol, the placement of the abutment happens at the same time as the surgical placement of the implant. Research has shown that micro motion less than 150 to 200 μm does not cause failure in osseointegration [1-2]. However, most studies have reported that to achieve successful outcomes, the maximum safe motion would be 100 to 150 μm [3]. Depending on the specific system used, an abutment can include a machined connection mechanism within itself (tapered implant) or can be clamped onto the implant by means of an abutment screw. The dental prosthesis is then fabricated over the abutment. The restoration for a fully edentulous mandible consists mainly of a U-shaped prosthesis, supported by anteriorly (front) placed fixtures and with posterior (back) extensions (cantilever) (Figure 1) [3-7].

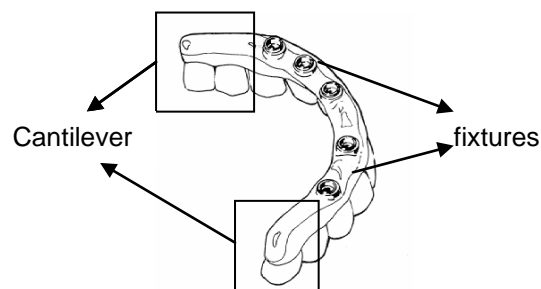

Figure 1: A typical complete-arch prosthesis [7].

Successful implant therapy requires a dynamic equilibrium between biological and mechanical factors. The biological factors are generally considered multi-factorial, whereas mechanical failure has been associated with screw joint instability between the abutment and the implant [4, 6, 8-10]. In tightening the abutment screw, a compressive force is generated that maintains contact between the bearing surfaces of implant and abutment. The success of this screw joint is directly related to the stretch of the abutment screw or the preload achieved from the tightening torque and maintenance of this preload over time. If the screw loosens and the preload falls below a critical level, joint stability may be compromised and may potentiate clinical failure. This includes soft tissue complications, abutment screw fracture, framework fracture, and abutment screw loosening. In most follow-up studies this screw loosening is reported as the most common complication. Overall, most investigators claim the better the maintenance of preload, the better the long-term stability of the joint. Factors that may result in screw joint instability or micro motion include inadequate preload, inadequate (screw) design, poor component fit, settling of surface micro roughness, excessive loading, and elasticity of bone. When tapered interference fits are used, abutment loosening seems to be less of a problem. The biting force acts in the direction of the abutment insertion, hence aids to secure the connection.

Any external tension load that is less than the preload will be taken up as a small increase in the screw tension and a larger decrease of the compression force on the cylinders. To obtain this favourable function in the screw joint, the preload must be maintained so that the screw joint will not open up. As soon as opening occurs, all of the external tension load has to be taken entirely by the screw. The opening of the screw joint, or its loosening, is the primary cause of screw breakage. If fracture occurs, it should preferably be the screw, since this component is the easiest to replace. The process of screw loosening has been described as occurring in 2 phases, both involving loss of preload. The first phase occurs as the preload is eroded because of slippage between threads as a result of functional forces. The second phase of loosening occurs when the preload has been eroded to the extent that any external load or vibration causes the threads to turn or "back off" [9]. To accomplish the desired function of the screw joint, the following conditions should be met: (1) optimal preload should be achieved and (2) there should be a precise fit between the implant and the abutment [7].

2 ELASTIC PROPERTIES OF THE HUMAN YAWBONE

The experimental measurement of the mandibular mechanical characteristics, although not impossible, is limited due to the restriction in cost, patient availability and other factors. The elastic constants quantify the relationship between a load (stress) placed on a structure and the resulting deformation of that structure (strain), within its elastic range. Elastic constants and ultimate strength can be related in bone. For instance, in the mandible, cortical bone is most resistant to deformation in the direction in which it is also the strongest. However, if a wider variety of bone types are examined, there is an overall inverse relationship between stiffness and strength which is related to the degree of mineralization [11-12].

Values of bone strain along the human mandibular corpus of up to 800 $\mu\epsilon$ in human mandibles loaded with artificial muscle forces up to 60 kilopounds (± 270 kN) have been published. Densities for each sample were determined using Archimedes' principle, the result was a bone density of 1.768 ± 0.115 g/cm³ ($= 1768 \pm 115$ kg/m³) [11].

Because bone is an anisotropic material, its elastic properties vary with direction. The most significant differences in elastic moduli were found between the longitudinal direction and the other two directions tested in the mandible (Table 1 and Figure 2). Significant differences in shear moduli were found for different orientations (Table 1). Mandibular bone samples were not taken from the edentulous individuals, as data from several specimens suggest that edentulation renders mandibular bone slightly less dense and less stiff [11].

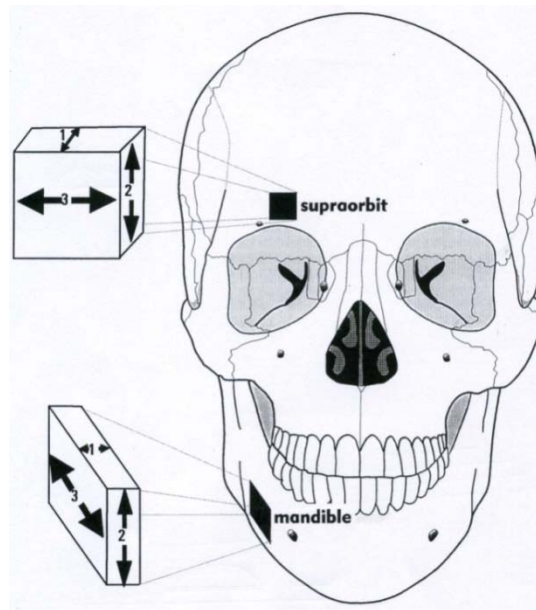

Figure 2: Orientations in bone samples taken from the mandible [11]

$E_1 =$	$11.3 \pm 2.4 \text{ GPa}$	$G_{12} =$	$4.5 \pm 1.0 \text{ GPa}$
$E_2 =$	$13.8 \pm 2.8 \text{ GPa}$	$G_{13} =$	$5.2 \pm 1.0 \text{ GPa}$
$E_3 =$	$19.4 \pm 4.0 \text{ GPa}$	$G_{23} =$	$6.2 \pm 0.7 \text{ GPa}$

Table 1: Elastic moduli and shear moduli measured on bone in the mandible [11]

The differences between edentulous and dentate mandibles were studied in [13]. The results show that throughout most of the edentulous mandibles, cortical bone was significantly thinner than in dentate mandibles. No significant differences in density between edentulous and dentate mandibles were found. This suggests that cortical bone density following edentulation is maintained despite changes in structure, stiffness and anisotropy. The differences in elastic moduli and shear moduli between the edentulous and dentate mandibles are shown in Table 2. This suggests that three-dimensional structural changes can occur within cortical bone, while density changes little [13].

Edentulous:	Dentate:		Edentulous:	Dentate:
$E_1 = 12.5 \pm 2.3 \text{ GPa}$	$E_1 = 12.7 \pm 1.8 \text{ GPa}$		$G_{12} = 4.5 \pm 0.9 \text{ GPa}$	$G_{12} = 5.0 \pm 0.6 \text{ GPa}$
$E_2 = 17.9 \pm 3.3 \text{ GPa}$	$E_2 = 17.9 \pm 2.5 \text{ GPa}$		$G_{31} = 5.3 \pm 1.0 \text{ GPa}$	$G_{31} = 5.5 \pm 0.7 \text{ GPa}$
$E_3 = 26.6 \pm 5.9 \text{ GPa}$	$E_3 = 22.8 \pm 5.4 \text{ GPa}$		$G_{23} = 7.1 \pm 1.1 \text{ GPa}$	$G_{23} = 7.4 \pm 0.8 \text{ GPa}$

Table 2: A comparison of elastic moduli and shear moduli for edentulous and dentate mandibles [13]

According to the index of Lekholm and Zarb, the jawbone can be divided into four different classes of bone quality, where class 4 represents the poorest quality with a high proportion of trabecular bone (Figure 3). In the maxilla (upper jaw), the dominant bone type is trabecular bone. The thin layer of cortical bone can make it difficult to achieve primary stability, which is a prerequisite for successful osseointegration. Several studies report lower implant success rates in the maxilla than in the mandible, which often has a higher proportion of cortical bone. Other authors are of the opinion that the high proportion of trabecular bone in the maxilla makes bone tissue more sensitive to optimal healing conditions [14].

231 Classification of bone quality according to Lekholm and Zarb (1985)

- Class I** Jaw consists almost exclusively of homogeneous compact bone
- Class II** Thick compact bone surrounds highly trabecular core
- Class III** Thin cortical bone surrounds highly trabecular core
- Class IV** Thin cortical bone surrounds loose, spongy core

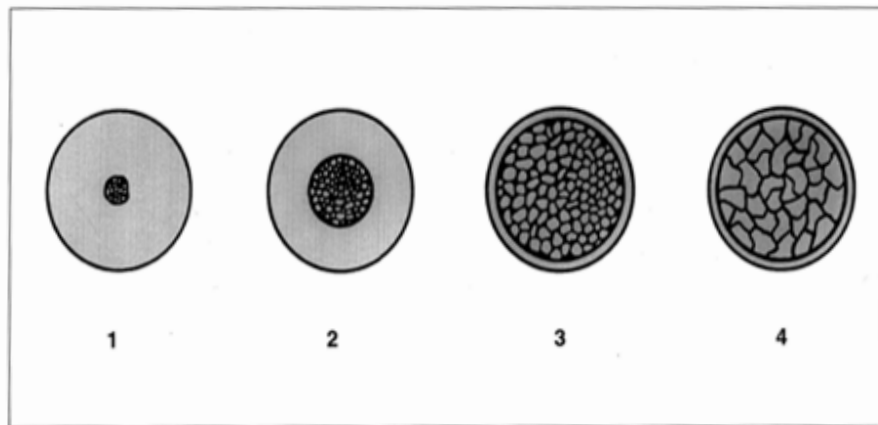

Figure 3: Classification of bone quality according to Lekholm and Zarb (1985) [15].

3 HUMAN BITE FORCE

Mastication mainly induces vertical forces in the dentition. However, transverse forces are also created by horizontal motion of the mandible and the inclination of tooth cusps (Figure 4). These forces are transferred through the prosthesis into the fixture, and finally into the bone. During this force flow, a given occlusal force creates completely different patterns of strain and stress because of the geometric configuration of the prosthesis in question [7].

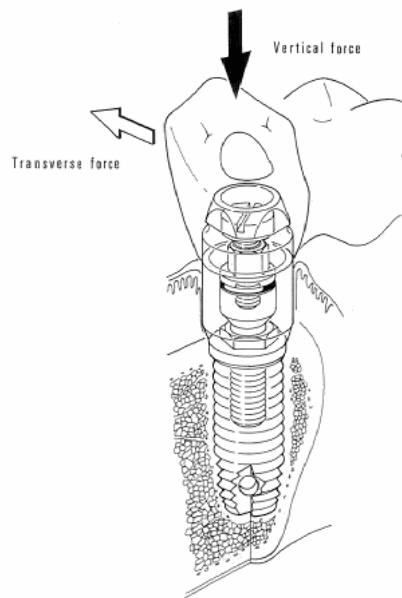

Figure 4: Vertical and transverse forces from occlusion acting on an implant prosthesis [7].

Two completely different types of loading are axial forces and bending moments. The axial force is more favourable, as it distributes stresses more homogeneously throughout the implant. The bending moment exerts stress gradients in the implant as well as in the bone. Axial forces can be of a compressive or a tensile nature. A compressive force presses the components of the system together and normally does not introduce any mechanical problems in the anchorage unit itself. On the other hand, tensile loading refers to a force that tends to separate components. Therefore, this force is of the greatest concern in regard to mechanical failure. The most essential aspect of this situation is the significance of the ratio of cantilever length relative to interfixture distance (a/b) (Figure 5). How this ratio approximately influences the tension load on an implant resulting from an occlusal force is shown in Figure 6 [7].

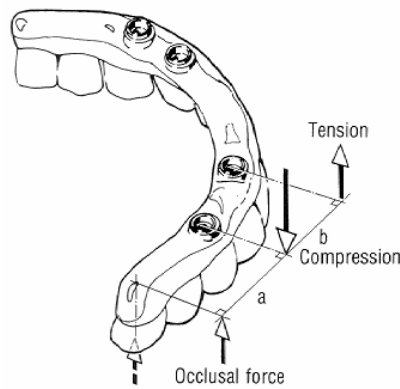

Figure 5: The implant loads induced by an occlusal force [7].

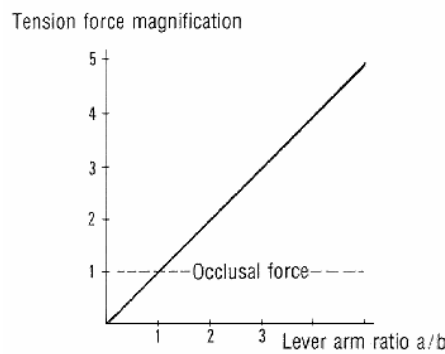

Figure 6: Tension force magnification as a function of the lever arm ratio (a/b) [7].

Forces are usually supported by first and second molars and second premolars in each arch (Figure 7) [16-17]. The greatest bite force recorded in a study was 435 N, but the teeth of the test person were abraded in evidence of his bruxing-clenching habit. This proves that the bite strength in some bruxer-clenchers can be as much as six times that of the non-bruxer. In Table 3 the bite force of other (normal) subject groups are listed [16].

Subject group	N	Range	Average	Reference and year
Natural teeth	20	55 to 280 lbs (25 to 127 kg)	162 lbs (74 kg)	Gibbs et al., ⁶ 1981
Complete denture	5	22 to 47 lbs (10 to 21 kg)	35 lbs (16 kg)	Colaizzi et al., ⁷ 1984
Maxillary complete denture-mandibular overdenture	6	14 to 159 lbs (6 to 72 kg)	51 lbs (23 kg)	Sposetti et al., ⁸ 1985

Table 3: Bite force in other subject groups [16]

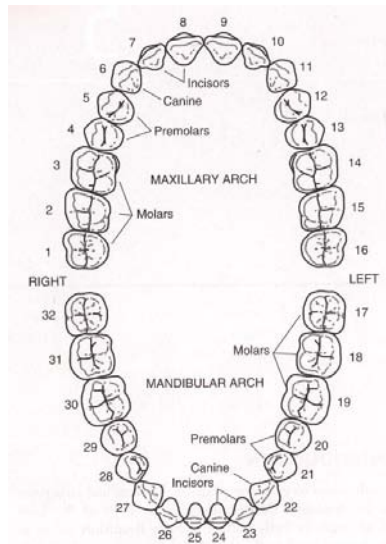

Figure 7: Numbering of the teeth (<http://www.toothmingle.com/information/what-is-tooth-numbering/>)

Generally, both bite force and occlusal contact area of male patients are greater than those of female patients (Table 4) [18]. Research has shown that the maximum human bite force can range from 200 N to 2440 N and that the lateral component is about 20 N [9].

	male	female	mean
Bite force of healthy subjects (N)	721.0 ± 505.5	530.7 ± 204.6	625.9 ± 387.9
Occlusal contact area of healthy subjects (mm ²)	16.6 ± 13.0	11.5 ± 5.1	14.1 ± 10.0

Table 4: Bite force and occlusal contact area of healthy persons [18]

4 IN VITRO STUDIES

4.1 Static loading

Static failure conditions occur when bending or axial force causes stresses larger than the yield strength of the screw, resulting in a permanent deformation of the screw. In such situations, there is a loss of preload (tensile force) in the screw stem, thus the implant–abutment joint opens and/or the abutment screw loosens [10].

In a first experimental study, clinical conditions were simulated. The crowns were provided with a V-formed notch 6mm from the crown margin. A compressive force was applied to the notch, resulting in a bending load on the system (Figure 8). The whole sample, consisting of implant, abutment, gold crown and one (or in certain cases two) screw was embedded in auto-polymerizing acrylic resin in a well fitting brass pipe. Once aligned in a universal test machine, a compressive load was applied to the sample at a rate of 0.1mm/s until failure (screw loosening, screw fracture, screw deformation or abutment fracture) of the sample was evident [6].

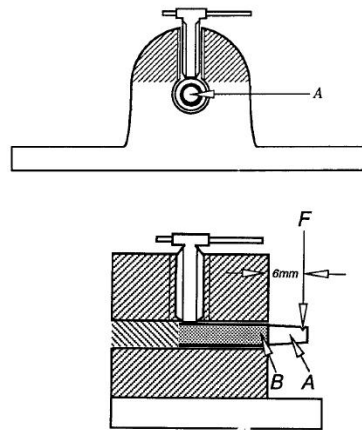

Figure 8: Experimental setup for static loading of dental implants [6]

The failure forces ranged from 138N to 693N. In this investigation, the load was a pure bending force, being perpendicular relative to the longitudinal axis of the sample, which is not clinically relevant. If a more axially oriented loading had been applied, then the samples would probably have tolerated a greater load before failure, and the failure forces would consequently have been larger [6].

In a second experimental study the tests were done using artificial bone (with representative mechanical properties) made of glass fibre reinforced composite and structural foam (Figure 9). The cross section dimensions of the artificial bone are for a typical mandible (Figure 9). An axial load was applied onto the implant head until failure was reached. For the classical geometry this was at approximately 50-55kg (± 500 N), for the special geometry this was at approximately 70kg (± 700 N) [19].

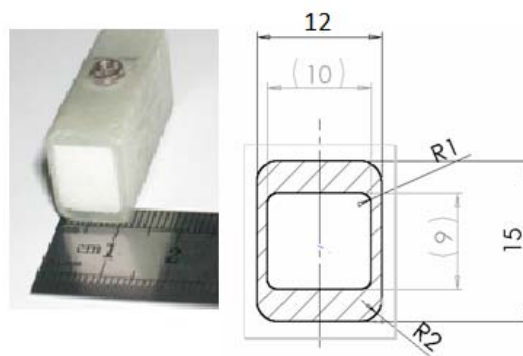

Figure 9: Artificial bone specimen and the dimensions [19].

4.2 Dynamic loading

Fatigue failure can occur when a force below the ultimate strength of the abutment screw is cyclically exerted on the system. Micro motion in the screw system can lead to cracks in the material at the implant surface as well as at the abutment and screw joint interfaces [10].

In a first experimental study, dynamic loading was applied to the 25-degree offset angulated platform of each abutment by a unidirectional vertical piston, cycling between 20 and 200N (Figure 10). A sinusoidal waveform was applied at a frequency of 8 cycles per second to simulate values found in human mastication. Cyclic loading continued for 5000000 cycles, or the approximate equivalent of 5 years of in vivo mastication [8]. The number of loading cycles were based on the assumption that an individual has 3 episodes of chewing per day, each 15 minutes in duration at a chewing rate of 60 cycles per minute (1Hz). This is equivalent to 2700 chewing cycles per day or roughly 10^6 cycles per year [9].

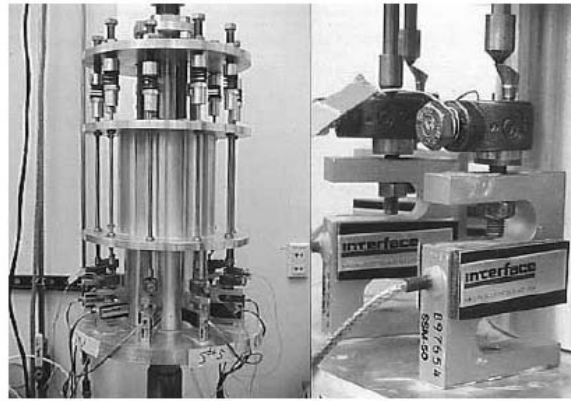

Figure 10: Carousel-type fatigue testing device [8]

In a second experimental study, the experimental device uses a linear solenoid to create a magnetic field that cycles the loading stylus at a user-defined rate (Figure 11). The solenoid chosen for this project allowed the device to cycle from 0 to more than 20 cycles per second while providing a load in the range of 0 to greater than 200 N for a duty of 500,000 cycles. The advantage of this device is its capacity to cycle at a faster rate than a conventional screw or hydraulic testing machine. The relative disadvantage of this device is the need to calibrate each specimen each time a loading period is performed. Loading was localized on the cantilever side of the implant joint opening, 4 mm from the center (Figure 11). The loading position of 4 mm off-axis was chosen to simulate a force applied to a cusp on a molar [10].

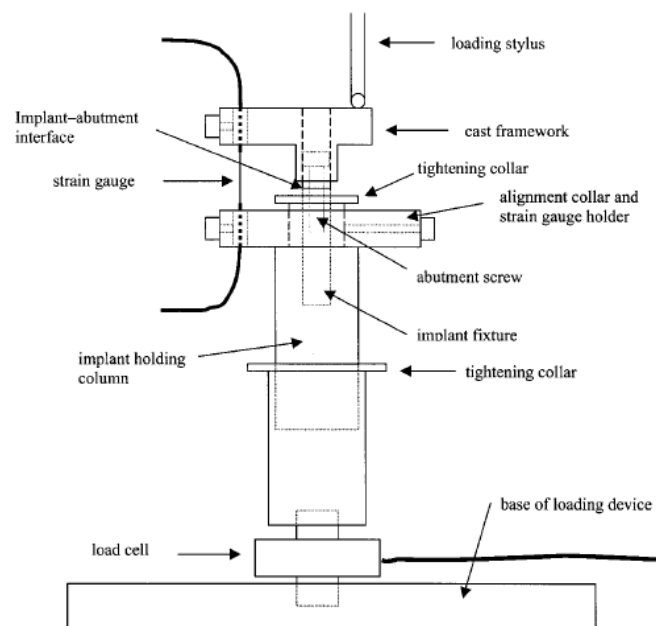

Figure 11: Solenoid driven dynamic loading test apparatus (schematic) [10]

5 FINITE ELEMENT ANALYSIS (FEA)

Different studies agree that biomechanical behaviour plays an important role in the survival of an implant, and that the finite element method (FEM) can be a reliable tool for studying this phenomenon. The degree of accuracy of the FEM is related to the knowledge of real load and supporting conditions. But it should be noted that the validity of simulation highly depends on assumptions made in modeling geometry, material properties, boundary conditions and the bone-implant interface. So that is why the results obtained from finite element simulations need substantiation by clinical research [20]. This paragraph shortly discusses the modeling of the supporting bone and its interaction with the implant.

As discussed higher, bone is an inhomogeneous anisotropic material. However, most data on the elastic properties suggest that cortical bone can be effectively modeled as either an orthotropic or transversely isotropic material. In most FEA studies the model structures were assumed to be homogeneous, isotropic and to possess linear elasticity. To describe such mechanical behaviour, knowledge of the value of two parameters is sufficient: Young's elastic modulus (E) and Poisson's ratio (ν) [11-12, 20-23].

In a first FEA, the modeled section of the mandible was composed of spongiosa with a thickness of 7mm in the bucco-lingual direction (this is the cheek-tongue direction), surrounded by 2mm of cortical bone bilaterally (Figure 12). The elastic properties used in this FEA are listed in Table 5. In this study, the basic loading conditions, biting with occlusal contact at the site of the molars and premolars was investigated. This site corresponds quite well with the focal point of masticatory forces. A wide range of magnitudes for chewing forces has been reported in the literature. The magnitude of the vertical load in this study was set at 500N, the loading forces on the models were static [3, 12].

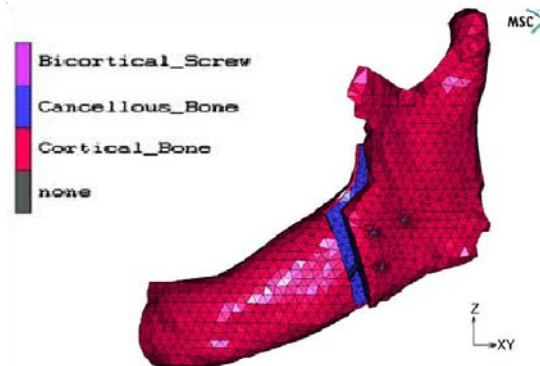

Figure 12: Modeled section of the mandible [12].

Material	Modulus of elasticity	Poisson's ratio
Cortical layer	13.7-14.8 GPa	0.3
Spongiosa/trabecular bone/cancellous bone	1.37-1.85 GPa	0.3

Table 5: Elastic properties used in the FEA [12, 20-22]

To investigate the initial stability for the situation immediately after implantation, the implant-bone interface was assumed as before the occurrence of osseointegration and simulated by non-linear contact zones with friction. The coefficient of friction was set to 0.3. This means that the contact zones transfer only pressure and tangential frictional forces (shear forces), whereas tension is not transferred [20].

Literature information on the precise material properties of maxillary trabecular bone is scarce. Trabecular bone is the dominant type in the maxilla, especially in the posterior regions where the surrounding compact bone often has a thickness less than 1mm. In a second FEA model, the maxilla was designed to be of homogeneous trabecular bone (Table 6) and to be isotropic and linearly elastic [14].

	Young's Modulus (E) [MPa]	Poisson's Ratio [ν]
Trabecular bone I	560	0.3
Trabecular bone II	273	0.3

Table 6: Material properties used in the FE Model of [14].

6 CONCLUSIONS

Based on an extensive literature review, this paper summarizes the main observations concerning the information needed to design and perform *in vitro* experiments and finite element simulations of dental implant-abutment systems. The real elastic properties of a human jawbone are provided. Reported studies showed that the properties are direction dependant. This is difficult to realise in FEA, and therefore the materials are mostly modelled as homogeneous isotropic and linear elastic. Also provided is the range of human bite forces, 200 to 2000 N. These forces are used in *in vitro* studies to simulate the static performance of implant systems or to simulate chewing cycles in fatigue tests. Based on this information, new *in vitro* experiments and finite element models will be designed and evaluated.

7 ACKNOWLEDGEMENTS

The authors would like to acknowledge the support of SouthernImplants and ProScan

8 REFERENCES

- [1] Pilliar, R.M., J.M. Lee, and C. Maniopoulos, *Observations on the Effect of Movement on Bone Ingrowth into Porous-Surfaced Implants*. Clinical Orthopaedics and Related Research, 1986(208): p. 108-113.
- [2] Viceconti, M., et al., *Large-sliding contact elements accurately predict levels of bone-implant micromotion relevant to osseointegration*. Journal of Biomechanics, 2000. **33**(12): p. 1611-1618.
- [3] Fazel, A., et al., *Micromotion and Stress Distribution of Immediate Loaded Implants: A Finite Element Analysis*. Clinical Implant Dentistry and Related Research, 2009. **11**(4): p. 267-271.
- [4] Bozkaya, D. and S. Muftu, *Mechanics of the tapered interference fit in dental implants*. Journal of Biomechanics, 2003. **36**(11): p. 1649-1658.
- [5] Taylor, T.D. and J.R. Agar, *Twenty years of progress in implant prosthodontics*. Journal of Prosthetic Dentistry, 2002. **88**(1): p. 89-95.
- [6] Mollersten, L., P. Lockowandt, and L.A. Linden, *Comparison of strength and failure mode of seven implant systems: An in vitro test*. Journal of Prosthetic Dentistry, 1997. **78**(6): p. 582-591.
- [7] Rangert, B., *Forces and Moments on Branemark Implants*. International Journal of Oral and Maxillofacial Implants, 1989. **4**(3): p. 7.
- [8] Cibirka, R.M., et al., *Examination of the implant-abutment interface after fatigue testing*. Journal of Prosthetic Dentistry, 2001. **85**(3): p. 268-275.
- [9] Gratton, D.G., S.A. Aquilino, and C.M. Stanford, *Micromotion and dynamic fatigue properties of the dental implant-abutment interface*. Journal of Prosthetic Dentistry, 2001. **85**(1): p. 47-52.
- [10] Hoyer, S.A., et al., *Dynamic fatigue properties of the dental implant-abutment interface: Joint opening in wide-diameter versus standard-diameter hex-type implants*. Journal of Prosthetic Dentistry, 2001. **85**(6): p. 599-607.
- [11] Dechow, P.C., et al., *ELASTIC PROPERTIES OF HUMAN SUPRAORBITAL AND MANDIBULAR BONE*. American Journal of Physical Anthropology, 1993. **90**(3): p. 291-306.
- [12] Erkmén, E., et al., *Comparison of different fixation methods following sagittal split ramus osteotomies using three-dimensional finite elements analysis - Part 1: advancement surgery posterior loading*. International Journal of Oral and Maxillofacial Surgery, 2005. **34**(5): p. 551-558.
- [13] Schwartz-Dabney, C.L. and P.C. Dechow, *Edentulation alters material properties of cortical bone in the human mandible*. Journal of Dental Research, 2002. **81**(9): p. 613-617.
- [14] Bergkvist, G., et al., *A finite element analysis of stress distribution in bone tissue surrounding uncoupled or splinted dental implants*. Clinical Implant Dentistry and Related Research, 2008. **10**(1): p. 40-46.
- [15] Spiekermann, D., *Implantology*. Color atlas of dental medicine. 1995, Stuttgart: Thieme.
- [16] Gibbs, C.H., et al., *LIMITS OF HUMAN BITE STRENGTH*. Journal of Prosthetic Dentistry, 1986. **56**(2): p. 226-229.
- [17] Olmsted, M.J., et al., *Human bite force: the relation between EMG activity and bite force at a standardized gape*. American Journal of Physical Anthropology, 2005: p. 160-161.
- [18] Harada, K., et al., *Measure of bite force and occlusal contact area before and after bilateral sagittal split ramus osteotomy of the mandible using a new pressure-sensitive device: A preliminary report*. Journal of Oral and Maxillofacial Surgery, 2000. **58**(4): p. 370-373.
- [19] Uri Arni, I.W., Oved Gihon, *Hybrid Dual Thread Screw Implant - Analytical and Experimental Research*. 2007.
- [20] Ding, X., et al., *Effect of Diameter and Length on Stress Distribution of the Alveolar Crest around Immediate Loading Implants*. Clinical Implant Dentistry and Related Research, 2009. **11**(4): p. 279-287.
- [21] Cehreli, M., M. Akkocaoglu, and K. Akca, *Numerical simulation of in vivo intraosseous torsional failure of a hollow-screw oral implant*. Head & Face Medicine, 2006. **2**(1): p. 36-36.
- [22] Borchers, L. and P. Reichart, *3-DIMENSIONAL STRESS-DISTRIBUTION AROUND A DENTAL IMPLANT AT DIFFERENT STAGES OF INTERFACE DEVELOPMENT*. Journal of Dental Research, 1983. **62**(2): p. 155-159.
- [23] Abu-Hammad, O., et al., *Effect of dental implant cross-sectional design on cortical bone structure using finite element analysis*. Clinical Implant Dentistry and Related Research, 2007. **9**(4): p. 217-221.