

Full-scale Laboratory Validation of a MEMS-based Technology for Post-earthquake Damage Assessment



D. Trapani, D. Zonta, M. Molinari

DIMS, University of Trento, via Mesiano 77, 38123 Trento, Italy

A. Amditis, M. Bimpas

ICCS, Institute of Communication and Computer Systems, 9, Iroon. Polytechniou Str., GR-157 73 Zografou – Hellas

N. Bertsch

MEMSCAP SA, Parc Activillage des Fontaines, ZI Bernin, 38926 Crolles Cedex, France

V. Spiering

C2V, P.O. Box 318, 7500 AH Enschede, The Netherlands

J. Santana

Holst Centre/Imec, Hight Tech Campus 31, 5656AE, Eindhoven, The Netherlands

T. Sterken, T. Torfs

Imec Belgium, Kapeldreef 75, 3001 Leuven, Belgium

D. Bairaktaris, M. Bairaktaris

D. Bairaktaris & Asc. Ltd, Pesmazoglou 17A, Kifissia 14561, Athens, Greece

S. Camarinopulos, M. Frondistou-Yannas

RISA Sicherheitsanalysen GmbH, Krumme Straße 55, 10627 Berlin-Charlottenburg, Germany

D. Ulieru

SITEX 45 SRL, Ghica Tei Blvd, 114, 023709, Bucharest 2, Romania

SUMMARY:

In this work a new generation of long-term monitoring system, named Memsccon, is presented. The Memsccon system consists of a set of sensor nodes using custom-developed capacitive MEMS strain and acceleration sensors, a low power wireless network architecture and a low power readout ASIC for a battery life of up to 10 years. The aim of the system is to provide the user information about the safety of reinforced concrete buildings while in service or after a seismic event. After outlining the monitoring system operation principles at both unit and network levels, this paper reports on a validation campaign conducted under laboratory condition on a full-scale reinforced concrete three dimensional frame, instrumented with Memsccon technology, undergoing a seismic-like event up to extensive damage and collapse. Finally, a comparison between the performance of Memsccon technology and the performance of different tethered measurements system assumed as reference is reported.

Keywords: Reinforced Concrete, Laboratory Validation, Seismic Analysis, MEMS, Decision Support System

1. INTRODUCTION

The Memsccon Project is an EC co-founded research project which aims to develop a cost-efficient, effective monitoring system to be installed in new reinforced concrete (RC) buildings, for their protection against earthquake and unforecasted settlement. With this purpose, a new-generation of acceleration and strain sensors based on Micro-Electro-Mechanical-Systems (MEMS) and Radio-Frequency-Identification (RFID) technologies interfacing with a specifically designed software have been developed within the project. The system layout, illustrated in Figure 1, consists of a network of strain and acceleration sensors installed inside the building, recording data when a severe seismic

event occurs or when it is scheduled by the user. The sensors (Santana J. et. al., 2011, Torfs T. et. al., 2011) transmit data wirelessly to a remote acquisition unit where data are stored, processed and interpreted using the developed software. This software consists of a damage assessment module and a decision support module, providing respectively an estimation of the level of damage inside the building and an insight of the rehabilitation methodologies and costs.

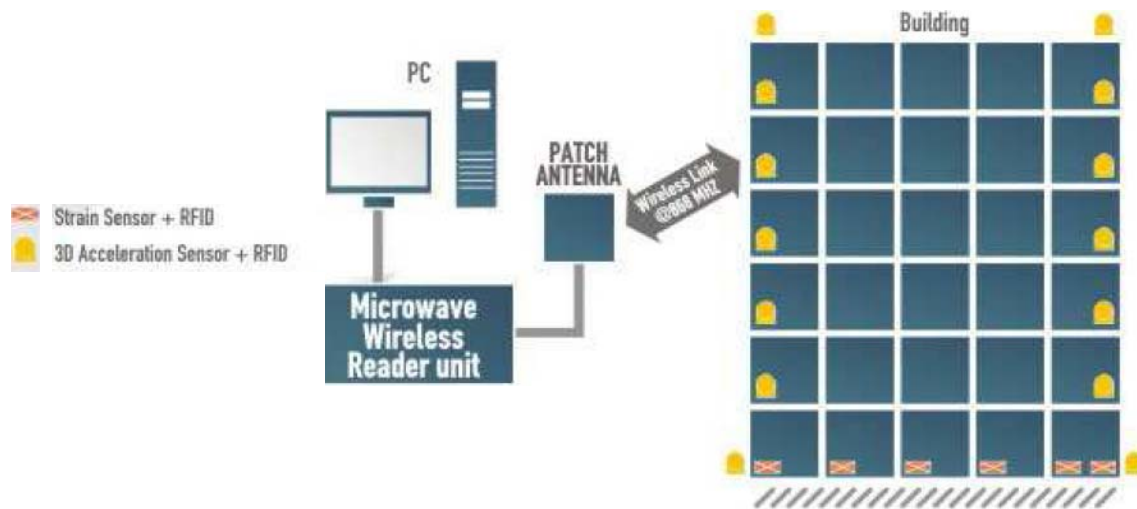

Figure 1. Memscon layout

In the Memscon system the accelerometers are installed in pairs at every floor of the building, measuring the response of the structure to the ground motions in terms of acceleration. Acceleration measures are used in order to perform a damage assessment analysis, estimating the displacements by the double integration of accelerations and imposing them to a finite element model of the structure; the output for the user are the information about the structural safety.

The designed accelerometers (Figure 2c) are three-dimensional capacitive MEMS accelerometers based on different technologies: while for the in plane accelerations (X and Y channels) the sensor has a interdigitated-comb structure, for the out of plane acceleration (Z channel) a pendulum system is used. These MEMS devices are packaged inside a plastic housing together with a lithium battery, an ASIC, an ADC, a Zigbit module and an antenna. Features of the device are 200 Hz sampling rate, a 54 seconds maximum acquisition period, 16 bit resolution, 2,5V range of the ADC. Moreover, the Memscon acceleration sensor is characterized by a reduced energy consumption, due to the fact that it remains in the idle state until a seismic event particularly relevant occurs.

The Memscon strain sensors (Figures 2a and 2b) are designed to be directly bonded to the reinforcing bars embedded in the RC columns at the ground level, namely at the interface between foundation and column. The strain measures, recorded in correspondence of three reinforcing bars inside the element, are used to indirectly estimate the stress inside the whole building, recognizing any stress changes due to unforecasted settlement or overloads. Besides this, strain sensors provide the deformed shape of the structure from which the structure undergoes damage due to the earthquake, and the strain field inside the building after the seismic event. The Memscon strain sensor consists of two parts: the front-end sensor embedded into the RC element and the mote to be attached externally. The front-end sensor is a capacitive MEMS strain sensor connected to an ASIC, both embedded in a PDMS substrate 4 cm long and 5 mm thick. The whole package is bonded to a polyimide carrier 8 cm long and 1 cm wide, to be bonded in turn to the reinforcing bars, by using a cyanoacrylate glue. The external mote is instead a plastic housing (externally identical to the housing of the accelerometer) inside which there are a lithium battery, a Zigbit module and an antenna. The mote allows for connection up to three strain sensors at a time, in order to reduce to one the required number of devices per columns.

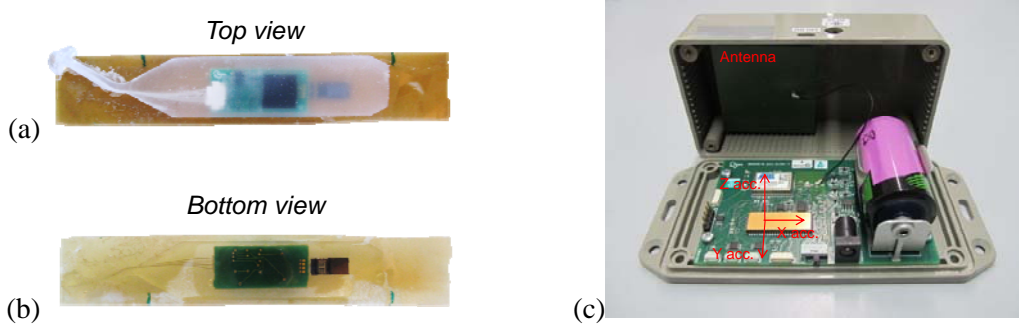

Figure 2. Memsccon strain sensor top view (a) and bottom view (b); Memsccon accelerometer (c)

2. PROTOTYPE BUILDING

The Memsccon technology was preliminary validated performing static and dynamic tests on small-scale reinforced concrete specimens (Pozzi M. et. al., 2011, Zonta D. et. al., 2011). In this work, both Memsccon strain sensors and accelerometers, as well as Memsccon damage assessment methodology and software, were instead validated installing the system into a three-dimensional RC frame specimen, tested under laboratory conditions inducing to it different seismic events of increasing amplitude. The frame had been extracted from a two floors prototype building sited in a seismic zone, showed in Figure 3, in order to reproduce in laboratory the dynamic response of such a building when undergoing an earthquake. The frame realized in laboratory consisted of four foundation beams anchored to the ground, with the aim to reproduce the full restraint, four columns, four beams along orthogonal directions and a concrete slab. The prototype building from which the frame was extracted had been selected as a commercial building, consisting of two different parts, named simply part A and part B: part A was assumed to be in concrete, with plane dimensions 12.3x12.3 meters, while part B was assumed to be in precast concrete, with plane dimensions 26.9x12.5 meters. The lateral stiffness of part B was assumed equal to zero in both directions, hence the total lateral stiffness of the building was considered as offered by part A of the building only. The 25 300x300 mm columns of part A were pitched in plan at 3x3 meters and were parts of frames connected by beams section 300x500 mm along the length and 300x500 along the width. The vertical floor pitch was 3.20 meters so the columns had a net height of 2.80 meters. The total load of each floor was estimated at 1368+1022 kN. The seismic mass of Part B of the prototype building was instead estimated as equal to 3305 + 2485 kN. The vertical loads applied to both parts of the prototype building were used to estimate the vertical load applied to the columns during an earthquake; considering the columns pitch, the load applied to each column in seismic combination was 150 kN. In order to study the whole structure, we adopted a two degrees of freedom system, characterized by a stiffness equal to the stiffness of the part A of the building and the two seismic masses equal to those of both A and B parts. We obtained, assuming the structure behaviour as the behaviour of a shear type structure and the column stiffness as the stiffness near to bars yielding, bending stiffness $K = 25k$ where $k = 3650$ kN/m is the bending stiffness of the single column, and seismic masses m_1 and m_2 equal to 4685 kN and 3515 kN respectively. The natural frequencies of such a system can be expressed as:

$$\omega_{1,2} = \frac{m_1 k_2 + m_2 k_1 + m_2 k_2 \pm \sqrt{(m_1 k_2 + m_2 k_1 + m_2 k_2)^2 - 4m_1 m_2 k_1 k_2}}{2m_1 m_2} \quad (2.1)$$

If $m_2 = 3/4 m_1$ the first eigenvalue, that is the frequency of the first vibration mode of the system (dominant in case of regularity in plan and elevation), can be approximated as:

$$\omega_1 \cong 0.682 \sqrt{\frac{k}{m}} = 0.682 \sqrt{\frac{25 \times 3650000}{468500}} = 9.43 \frac{\text{rad}}{\text{sec}} \cong 1.5 \text{ Hz} \quad (2.2)$$

This natural frequency, together with a 5% damping ratio was used to estimate the response of the prototype building to a spectrum compatible earthquake in accordance to Eurocode 8, characterized by the following parameters: site C class, topographic amplification factor 1, $S = 1.15$, $T_B = 0.20s$, $T_C = 0.60s$, $T_D = 2.0$ sec. The so evaluated displacement response of the first floor of the prototype building was used as test calibration parameter as illustrated in the sections below.

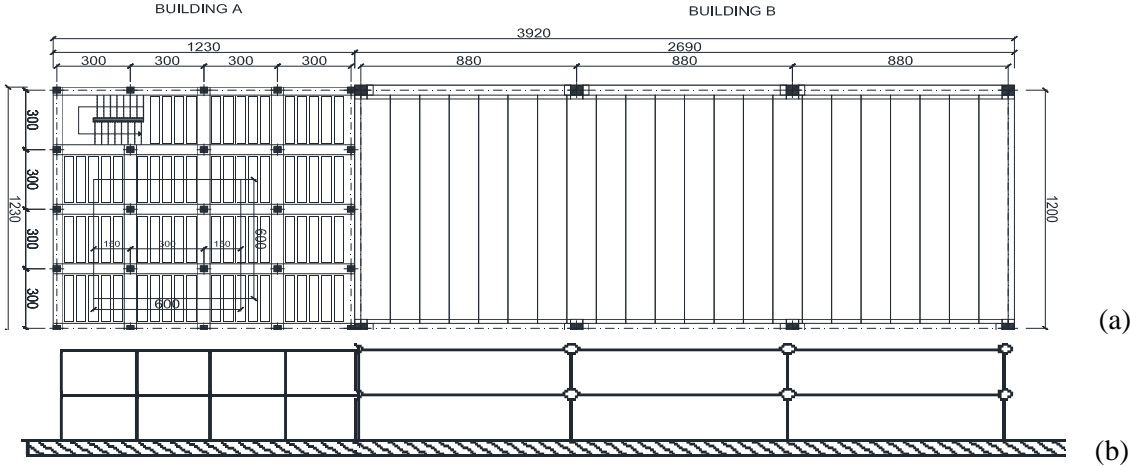

Figure 3. Plane view (a) and front view (b) of the prototype building

3. SPECIMEN CONSTRUCTION AND INSTRUMENTATION

As stated in the previous section the three-dimensional frame constructed in laboratory was extracted from the part A of the prototype building. The materials selected to construct the specimen were B450C steel reinforcing bars and C25/30 concrete. The dimensions of the frame were 3.20x6.35 meters in plane and 3.90 meters in elevation. The columns, named C1, C2, C3 and C4, were designed with section 300x300 mm, reinforced longitudinally with 4 ribbed 20mm steel bars type B450C and transversally with 8 mm diameter B450C stirrups, at 100 mm pitch, to avoid fragile failure due to shear. The longitudinal foundations were designed to avoid cracking during the experimental campaign. To obtain this, in addition to the massive cross section of dimensions 350x700 mm reinforced with 4+4 bars 16 mm diameter, the foundations were post-tensioned with a force of 1400 kN, increasing the first crack bending moment. The longitudinal top beams had section 300x500 mm and were reinforced with 2+2 bars 16 mm diameter, in addition to the 20 mm diameter bars connecting to the columns. The resisting bending moment was 1.5 times the one of the column. The concrete slab, 120 mm thick and reinforced with crossed 10 mm diameter bars spaced at 200x200mm, was designed to ensure the diaphragm behaviour of the deck. No loads were foreseen directly on the slab excluding its self-weight. The plane and the front views of the frame are showed in the following figure.

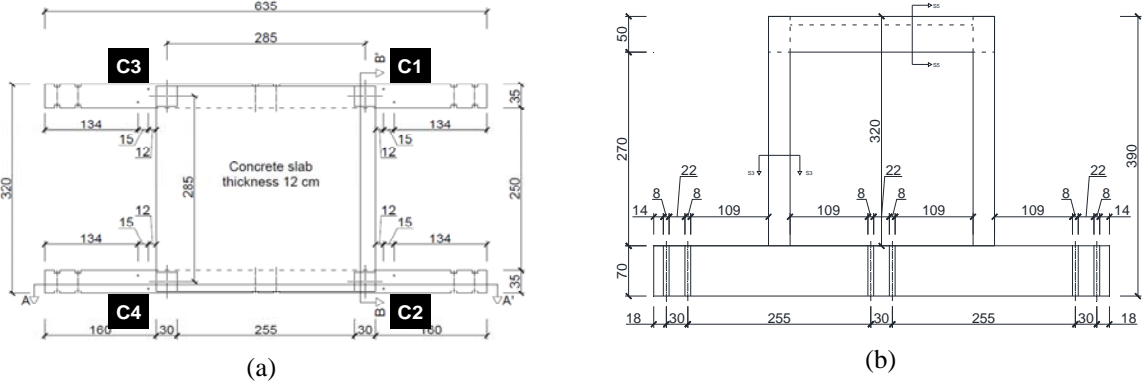

Figure 4. Plane view (a) and front view (b) of the three-dimensional RC frame

Each of the four bars inside each frame column were instrumented using the Memscon strain sensors and two reference strain sensors (LY41-3/700 strain gauges produced by HBM GmbH) with the aim to validate Memscon devices' response. The Memscon strain sensors were connected via cable to the motes, placed externally the columns and transmitting recorded data wirelessly to the Memscon receiver placed near the frame. The reference sensors were instead acquired using a wired acquisition system (National Instruments Field Point system, consisting of one FP2000 and 3 FPSG140). Both the systems were on during the construction of the frame, in order to monitor strains induced by the loads, creep and shrinkage. The strains have been recorded also during earthquake simulation, in order to know the deformed shape of the structure at the moment of the simulated earthquake.

Above the slab four Memscon accelerometers were installed, fastening them to the concrete surface using a set of screws. Back to back to them we mounted also a pair of reference accelerometers (piezoelectric accelerometers model PCB 393C produced by PCB Piezotronics), acquired by an acquisition unit NI PXI 4472B produced by National Instruments, in order to assess the accuracy of the Memscon devices compared with commercial available devices specifically intended for seismic measurements. Finally, during the dynamic tests we recorded also displacements. Besides the data acquired by the load application system (specifically by the horizontal actuator described below) a set of Linear variable differential transformer (LVDT) displacement transducers (Gefran LT-F-0500-S) were mounted along the columns at different heights and acquired every 0.1 seconds.

4. LOAD PROTOCOL AND TEST SETUP

A spectrum compatible earthquake was founded into the database attached to the Rexel software (Iervolino I. et. al., 2009): it is the earthquake occurred in Chenoua, Algeria, in 1989, characterized by a 0.22g PGA (Bounif A. et. al., 2003). The ground acceleration time history of this target earthquake was applied to the model discussed above and the displacement response at the first floor of the building was estimated using the Newmark's method, applied to a two-degrees-of-freedom model. This response was used as reference in designing the tests load protocol. Indeed, scaling the maximum displacement to different amplitudes had been possible to reproduce various damage scenarios in the prototype building, including cracking, steel reinforcement yielding and concrete spalling. A cantilever scheme for the columns were selected to obtain the different displacements, corresponding to the different levels of damage: it was obtained for example that the displacement at first cracking of the concrete (Δ_{crack}) was 1.5 mm to which a lateral force of 110 kN corresponded, while the displacement at yielding was 17.0 mm to which a lateral force of 304 kN corresponded.

The selected load protocol, showed in Figure 5, consisted of a vertical load, which was produced by a vertical actuator, MTS model 243.60, placed inside the frame, kept as constant during the application of the horizontal displacement time history (actually a reduction of the vertical force transmitted from the vertical actuator was detected in the central part of the tests), which was produced by an horizontal actuator, MTS model 244.51, reproducing the displacements at the first floor of the prototype building during the target earthquake. The load application system was designed in such a way that the vertical load was directly applied to the columns and not to the slab, which was not designed to resist to vertical loads. Moreover, the horizontal load was applied always pushing the slab and never pulling it, this achieved realizing a system consisting of a set of threaded bars in tension connected to a pair of steel plates external to the transversal beams, as showed in Figure 6. The test sequence was selected in order to induce cracking of the concrete at the interface between columns and foundations during the first earthquake simulation (maximum displacement equal to Δ_{crack}). Next, maximum displacements multiple of 25% the displacement expected at steel yielding (Δ_y) were produced up to yielding (25-50-75-100 Δ_y). Finally, the frame underwent maximum displacements multiple of 100% Δ_y (200-300-400-500-600 Δ_y).

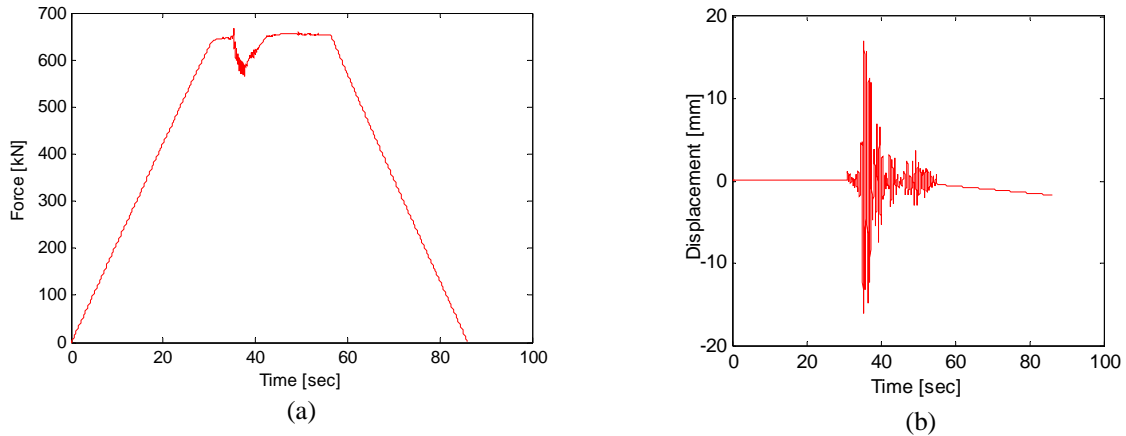

Figure 5. Time history of the vertical load (a) and of the horizontal displacement (b)

4. TEST OUTCOMES

Each dynamic test was characterized by a maximum displacement of the time history of displacement. This displacement was also statically applied to the frame after each dynamic test. The static tests allowed us to evaluate the evolution of damage in terms of stiffness loss due to the increasing earthquake intensity, and to record the force-displacement relationships of the RC frame. The displacements were recorded during the tests using the displacement transducers presented in the previous section, while the load was recorded by the load cell of the horizontal actuator. The displacements along the columns are shown in Figure 7a for different maximum displacements induced to the frame. Analysing the plot we hypothesize that a plastic hinge developed at the base of each of the columns during tests at 75% Δ_y or 100% Δ_y . Increasing damage was then observed also at the top of the columns: for example, the plot related to the 400% Δ_y test indicates a plastic hinge also at the interface between column and beam. Figure 7b shows instead the force-displacement plot, where energy dissipation by hysteresis is appreciable.

Each Memscon accelerometer was validated by comparing it with a couple of reference piezoelectric accelerometers, acquired using a NI PXI 4472B acquisition unit sampling 32768 measures at 1000Hz, mounted in two orthogonal directions in order to validate both the sensing directions of the Memscon device. We selected to measure acceleration in two points above the slab, one at the top of column C2 (sensors 103, 104) and the other at the top of column C3 (sensors 102, 106). All the devices were fastened to the concrete slab, recording in this way its actual acceleration. The comparison between the signals recorded during the induced shaking motion highlighted that no critical deviation in the response of the Memscon accelerometers occurred during the tests, in comparison with the wired reference sensors.

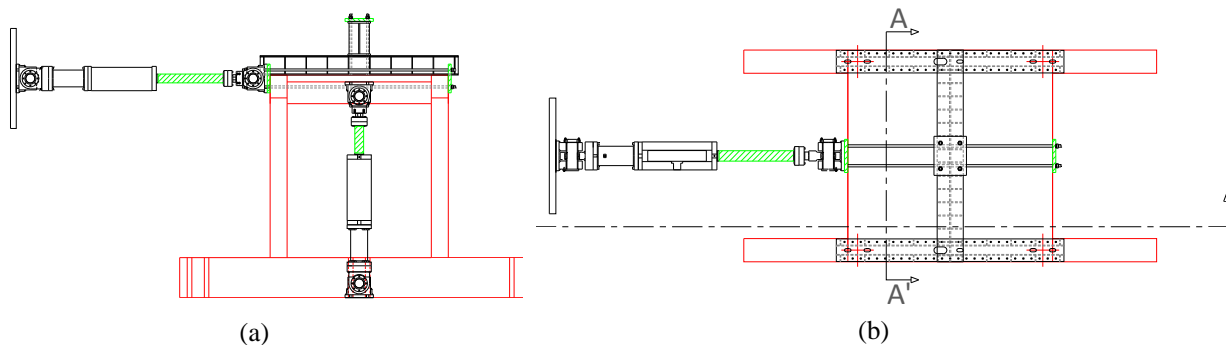

Figure 6. Front view (a) and plane view (b) of the loading system

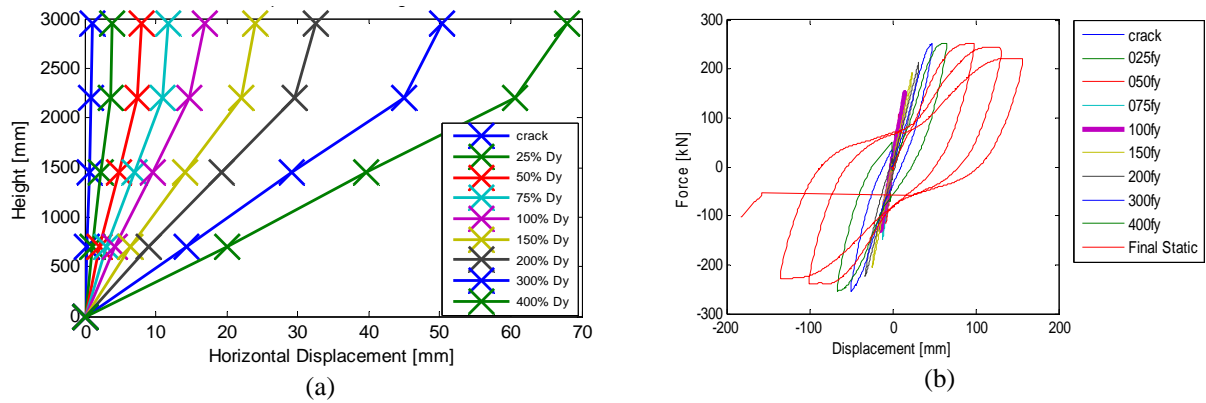

Figure 7. Displacements along column C3 during different tests (a), force-displacement plot (b)

Indeed, discrepancies less than 20 mg, evaluated in terms of RMS, were observed between the two monitoring systems, as it can be seen in Figure 8 below. Moreover, it is not clear if these discrepancy were due to the Memscon system or to the reference one. Even if the value of the background noise of the Memscon accelerometers is about 10-15 mg, the signals from the Memscon devices appears smoother than the signals from reference system. Reference signals are probably affected by some noise component, lacking from Memscon signals.

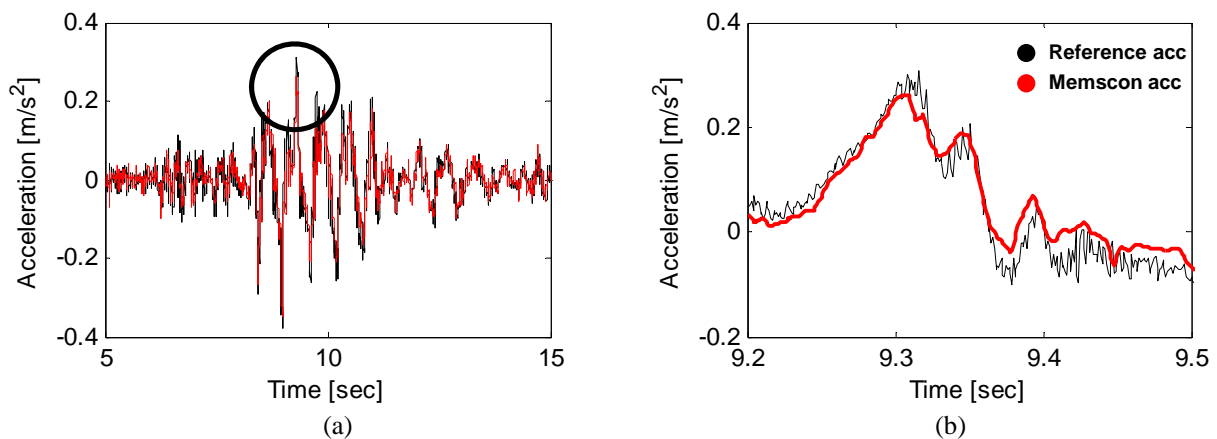

Figure 8. Comparison between Memscon accelerometer and reference accelerometer responses

The acceleration data recorded by the Memscon sensors were used to estimate the displacement time history induced in the frame by the horizontal actuator, double integrating the time histories. To do this, an high-pass filter was implemented during post-processing analysis, this characterized by 0.2 Hz stop band frequency, 1.2 Hz pass band frequency, 0.0001 stop band attenuation, 0.0575 pass band ripple and 20 density factor. The so estimated displacement time histories were compared to those recorded by the MTS system, which provided the displacement actually produced by the horizontal actuator. We observed that performing the double integration of the filtered signal it was possible to evaluate the displacement time history without inducing a drift to the response. For example the comparison between the displacement time history obtained by double integration of the accelerations recorded during tests 100 Δ y and the one actually produced during the same test, showed in the plot in Figure 9a, indicates a discrepancy of the order of 0.5 mm.

The acceleration measures were subsequently imported into the Memscon software in order to assess if it was able to provide the user with a reliable estimation of the maximum displacements induced to the frame during the tests. The software includes an high-pass filter, similar to the filter briefly presented above, which cuts low frequencies from the acceleration signals. The filtered signals are double-integrated and the maximum displacement is estimated. This target displacement value is

imposed to a finite element model of the structure, within an ETABS/SAP2000 environment, and a non-linear analysis is performed. For each element a damage index is calculated, comparing the force induced by the earthquake and the design forces. The output of the analysis is based on this damage index and is supplied in the form of a “traffic light”: the element is showed in red if severe damage occurred, in yellow if visual inspections are needed, in green if no damage occurred. The occurred damage is then expressed by a damage index. Figure 9b shows the output of the test $200\Delta_y$, during which a displacement two times the displacement expected at column reinforcement’s yielding: almost all elements are red, being this consistent with the severe damage occurred at the base of the columns.

5. CONCLUSIONS

Dynamic tests reproducing an actual earthquake of increasing amplitude were performed under laboratory conditions on a three-dimensional-reinforced-concrete-frame instrumented with Memscon technology. The frame underwent different levels of damage, such as concrete cracking, steel reinforcement yielding and concrete spalling. Memscon accelerometers, installed above the concrete slab, were validated comparing their response to the response of a set of reference piezoelectric accelerometers measuring in plane accelerations along both directions, assumed as reference. The observed discrepancy between Memscon devices response and reference devices is in the order of 20mg, evaluated in terms of root mean square, which is also the amplitude of the observed background noise. Preliminarily filtering the signals in order to remove low frequencies, Memscon accelerometers allows also the estimation of the displacement time history starting from recorded acceleration measures. The comparison between these estimation and the time histories of horizontal displacements actually induced by the horizontal actuator indicates that the estimation is reliable, being the discrepancy less than a few tenths of a millimetre. Recorded acceleration data have been also used to validate the modules of the Memscon software, which allows to assess the damage occurred into the building after a seismic event. after importing the acceleration measures into the software, it automatically deduces time histories of displacement, applying them to a finite element model of the structure. The output for the user is a three-dimensional representation of the building in which the elements are showed with colours depending on a damage index representing the occurred damage. The comparison between this output and the damage assessment manually performed and visually observed highlights that Memscon damage assessment methodology implemented into the software is reliable and effective.

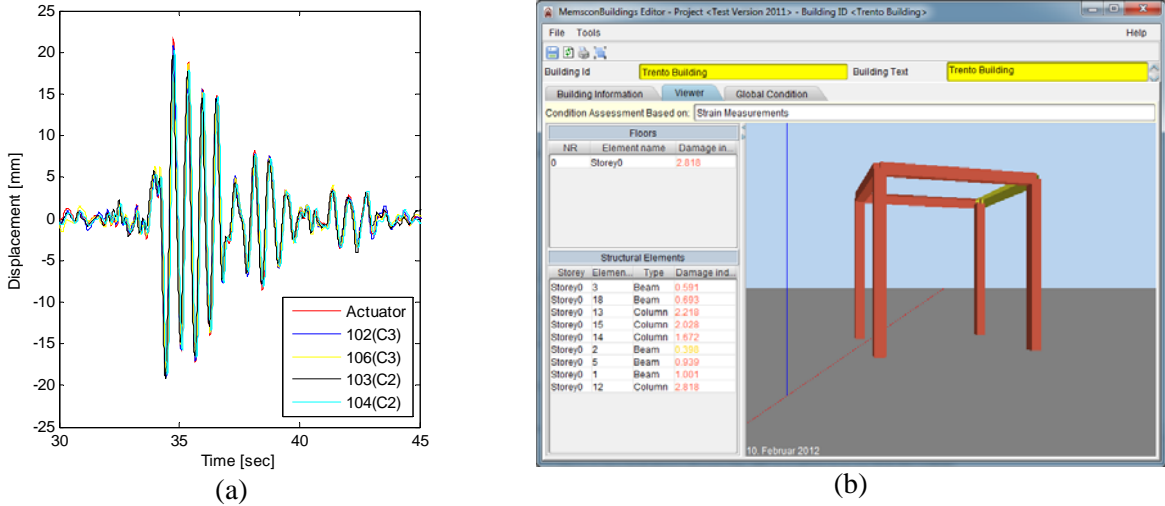

Figure 9. Comparison between displacements actually induced by the actuator and displacements estimated by double integrating the acceleration measures recorded by the four Memscon accelerometers (a), output of the Memscon software (b)

ACKNOWLEDGEMENTS

The Memscop project was funded by the European Community with Grant Agreement n. CP-TP 212004-2. The authors wish also to thank Giacomo Cigognetti and Daniele Coato, master students at University of Trento, and all the workers at the UniTN DIMS Laboratory for their invaluable collaboration during specimen design, construction and testing.

REFERENCES

- Bounif A., Bezzeghoud M., Dorbath L., Legrand D., Deschamps A., Rivera L., Benhallou H. (2003). Seismic source study of the 1989, October 29, Chenoua (Algeria) earthquake from aftershocks, broad-band and strong ground motion records. *Annals of Geophysics*. **46**:625-646.
- Iervolino I., Galasso C., Cosenza E. (2009). REXEL: computer aided record selection for code-based seismic structural analysis. *Bulletin of Earthquake Engineering*. **8**:339-362.
- Pozzi M., Zonta D., Trapani D., Amditis A.J., Bimpas M., Stratakos Y.E., Ulieru D. (2011). MEMS-based sensors for post-earthquake damage assessment. *9th international Conference on Damage Assessment of Structures*.
- Torfs T., Sterken T., Brebels S., Santana J., van den Hoven R., Saillen N, Trapani D., Zonta D., Marmaras P., Bimpas M., Van Hoof C. (2011). Low Power Wireless Sensor Network for Building Monitoring. *IEEE Sensors 2011*.
- Santana J., Van den Hoven, R., Van Liemp C., Colin M., Saillen N., Trapani D., Zonta D., Torfs T., Van Hoof C. (2011). A 3-axis accelerometer and strain sensor system for building integrity monitoring. *Sensors and Actuators A: Physical*.
- Zonta D., Trapani. D, Larcher F., Amditis A., Bertsch N., Bimpas M., Garetsos A., Saillen N., Santana J., Sterken T., Stratakos Y., Torfs T., Ulieru D. (2011). Laboratory validation of MEMS-based sensors for post-earthquake damage assessment. *8th International Workshop on Structural Health Monitoring*. **Vol I**: 2165-2172.