

Total harmonic current of a large number of non-linear single phase loads

Jan Desmet¹⁾, Isabel Sweertvaegher²⁾, Greet Vanalme³⁾, Ronnie Belmans⁴⁾

^{1, 2, 3)} HOGESCHOOL WEST-VLAANDEREN, DEPT. P.I.H.
Graaf Karel de Goedelaan 5, B-8500 Kortrijk, Belgium
Tel.: +32 56 24 12 39, Fax: +32 56 24 12 34
jan.desmet@ieee.org

⁴⁾ K.U.LEUVEN, DEPT. ESAT/ELEN
Kasteelpark Arenberg 10, B-3001 Leuven, Belgium
Tel.: +32 16 32 10 20, Fax: +32 16 32 19 85
ronnie.belmans@esat.kuleuven.ac.be

Keywords

Power quality, Harmonics, Single phase systems, Measurements

Abstract

The cumulative harmonic currents of a large number of non-linear single phase loads, particularly PC's and monitors, are investigated experimentally. In reference [1], it is shown, by means of an analytical model, that there is a significant attenuation of the current harmonics above the third when a large number of such loads is considered. In this paper, the simulation results are verified by measurements.

1. Introduction

Nowadays non linear loads (compact fluorescent lamps, computers, variable speed drives, ...), mostly used with the aim of rational use of electrical energy, are very common. Such loads, producing harmonic currents, can yield high neutral conductor currents [2-6]. However, in practice, the neutral conductor fusing and cross section of most installations is not rated for such high neutral conductor currents [7].

In this paper comprehensive measurements are reported on monitors and PC's in order to predict the neutral conductor current in case of a large-scale introduction of IT-equipment. The influence of the number of PC's and/or monitors on the cumulative current harmonic spectrum is considered, both at a sinusoidal voltage generated by a power source and at the supply voltage by the public distribution system. These results are discussed and compared with the simulation results [1].

2. Test configuration

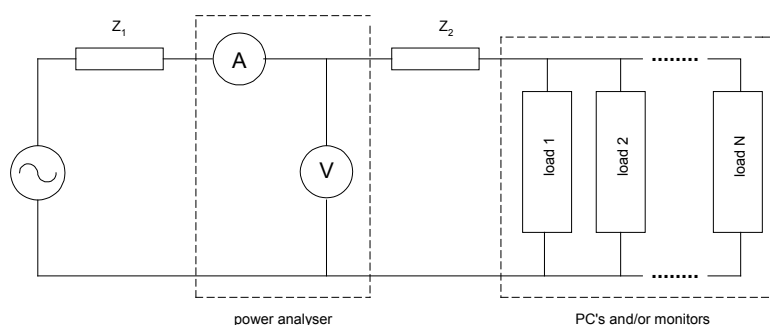

Fig.1. Measurement set-up

Measurements are performed in a computer room where a varying number of identical PC's and/or monitors are installed.

Two situations are considered. In the first one a sinusoidal voltage with rms-value 230 V, 50 Hz is generated by a programmable power source where the impedance Z_1 equals the minimum impedance of the power source (table I). In the second set-up the supply voltage from the public distribution network is used. In this case, Z_1 equals the short circuit impedance in the considered point of common coupling. In both situations the impedance Z_2 , the impedance of the cable connecting the load to the power analyser, and the impedance Z_A , the impedance of the power analyser, are the same.

An overview of the impedance values (resistance R and inductance L) is given in table I.

Table I: Overview of impedance values

supply voltage	Z_1	Z_2	Z_A (ampere-meter)
power source	R = 4 m Ω , L = 135 μ H	R = 58 $\mu\Omega$, L = 2 μ H	R = 3.5 m Ω
public distribution network	R = 700 m Ω , L = 30 μ H	R = 58 $\mu\Omega$, L = 2 μ H	R = 3.5 m Ω

3. Measurements

3.1 Measurements with the power source

The measurements are done with respect to the requirements given by the IEC standards [8].

Fig.2 shows the current waveform of a monitor. It is composed of a small sine wave about 90° leading with respect to the supply voltage and a peak just before the top of this voltage. The sine wave originates from the RFI filter of the power supply, while the peak comes from the rectifier bridge, containing the most energy. This current finger print is typical for monitors and PC's.

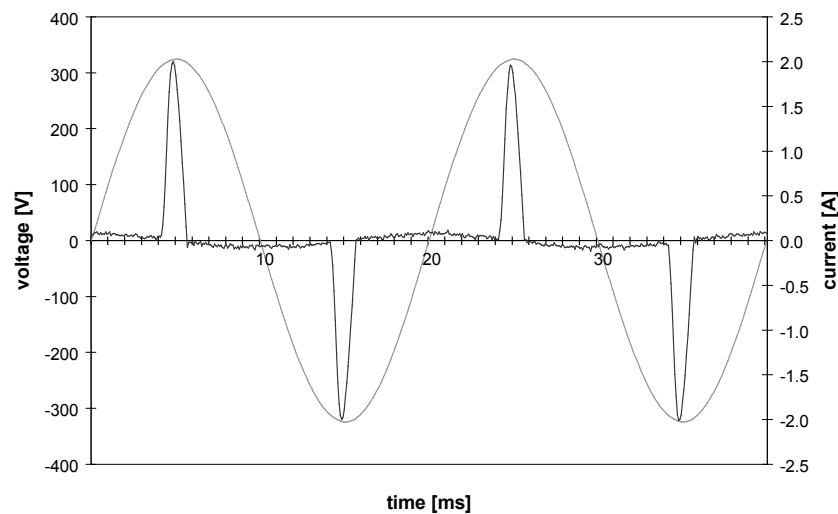

Fig. 2. Current and corresponding voltage of a monitor.

In figure 3 the normalised current waveform is shown for different numbers of PC's with monitor. Note that an increasing number leads to a widening of the peak. This widening is caused by both the flattening of the voltage peak due to voltage drop across the series impedance during the current peak and the small statistically different load currents. This leads to the attenuation of the higher order current harmonics. The total harmonic distortion of the current varies from 194 % (N = 1) to 147 % (N = 12).

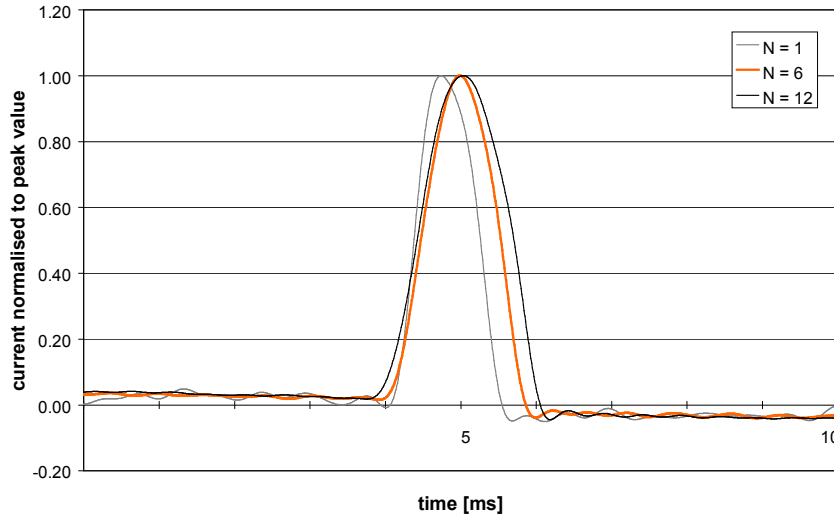

Fig.3. Influence of the number of PC's with monitor on the current waveform

Fig.4 shows the rms-value of the total current, the fundamental and the harmonics with order ≤ 19 as function of the number of PC's with monitor. There is a linear correlation between the number of loads and rms-values of the total current, its fundamental, 3rd and 5th harmonic. For the higher order current harmonics, the deviations from the linear relationship become more pronounced and even unpredictable with increasing harmonic order. One of the reasons for this unpredictable behaviour is the presence of voltage harmonics, highly affecting the current harmonics [4,5]. The voltage at the load contains harmonics because of the presence of the impedance ($Z_1+Z_2+Z_A$).

Notice that for one load the harmonic spectrum shows a monotonic decay of the increasing order harmonics, while this is not always true for several loads.

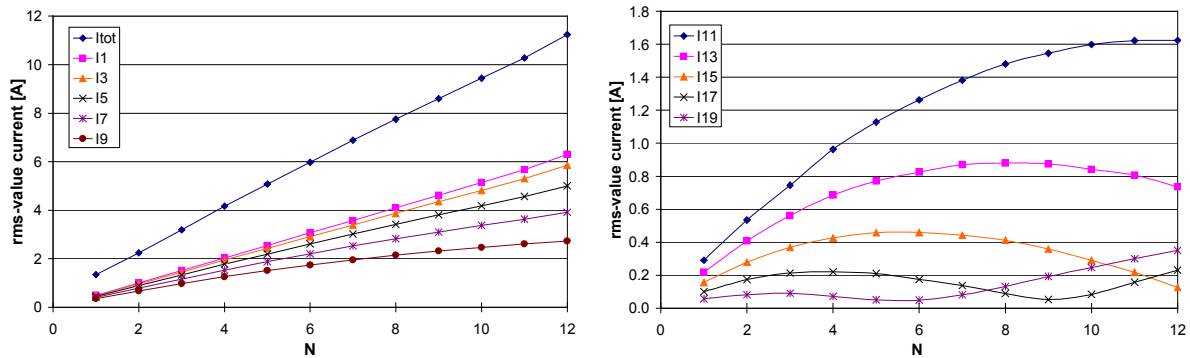

Fig.4. Rms-value of the total current, the fundamental and the harmonics with order ≤ 19 as function of the number of PC's with monitor

Fig.5 shows the attenuation factors for the harmonics [1]:

$$AF_h = \frac{I_h^N}{N \cdot I_h^1} \quad (1)$$

where I_h^N : Resultant current for harmonic h for N units operating in parallel
 I_h^1 : Current for harmonic h when N = 1

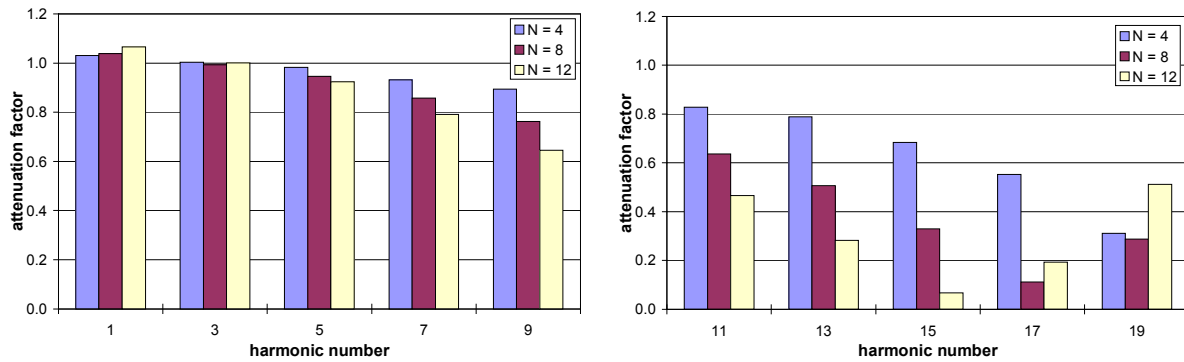

Fig.5. Attenuation factors of harmonic currents

As in reference [1], the attenuation due to the shared system impedance is more pronounced for higher order harmonics and tends to increase with N (leaving the 17th and 19th harmonic out of consideration).

3.2 Measurements at the voltage of the public distribution network

In figures 6, 7 and 8 the results are shown in case of a practical situation, where the total harmonic distortion of the supply voltage THD(U) is influenced by the line and source impedance (THD(U) = 1.10 %, 1.68 %, 2.57 % for N = 1, 12, 24 respectively). In comparison to the previous situation, there is a further widening of the current peak signal (figures 3 and 6), resulting in a lower total harmonic distortion of the current (THD(I) = 163 %, 123 %, 112 % for N = 1, 12, 24 respectively). For the higher order harmonics there is a larger deviation from the linear relationship between the rms-value and the load number (figures 4 and 7). This is due to the larger impedance causing a higher distortion of the voltage at the load. Variations in the supply voltage of the public distribution network can also be a cause.

Fig.8 shows that, for the current harmonics with order ≤ 9 , the attenuation factor decreases with the harmonic order and with the load number, in correspondence with the results of [1]. However, for some higher order harmonics, the attenuation factor can be higher than 1: these harmonics increase. Notice that the attenuation of the current harmonics with order ≤ 9 is stronger than in the previous situation because of the higher series impedance.

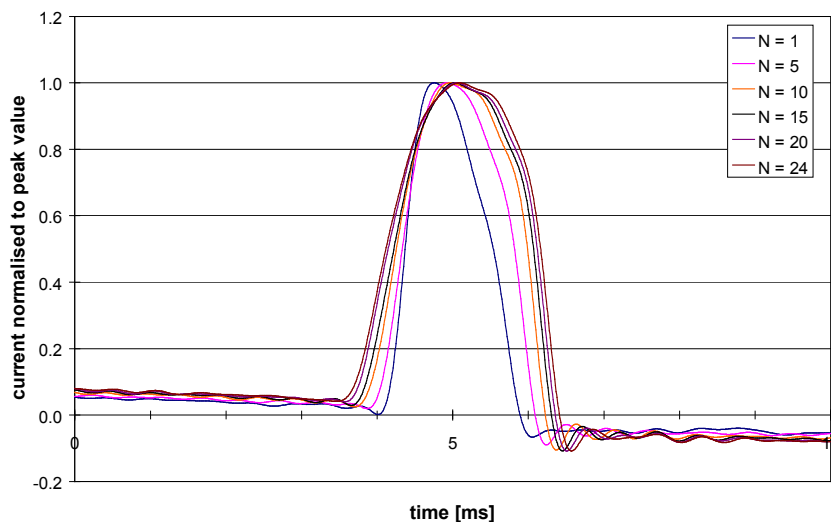

Fig.6. Influence of the number of PC's with monitor on the current waveform (voltage from public distribution network)

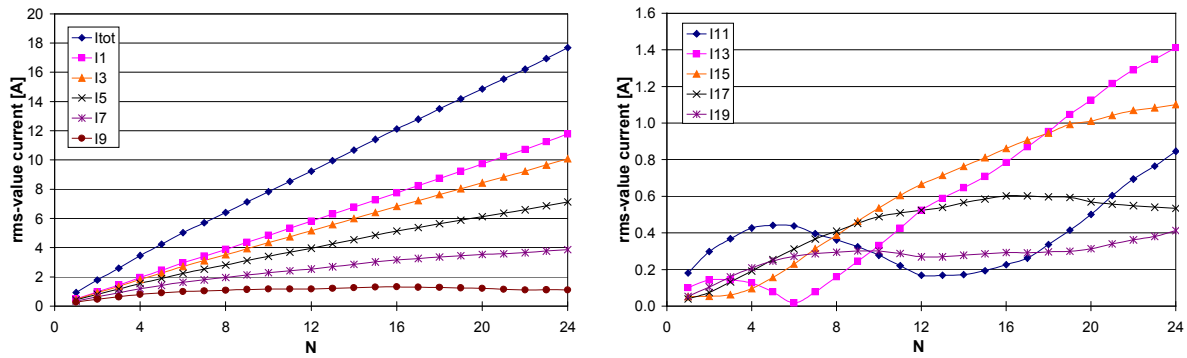

Fig.7. Rms-value of the total current, the fundamental and the harmonics with order ≤ 19 as function of the number of PC's with monitor (voltage from public distribution network)

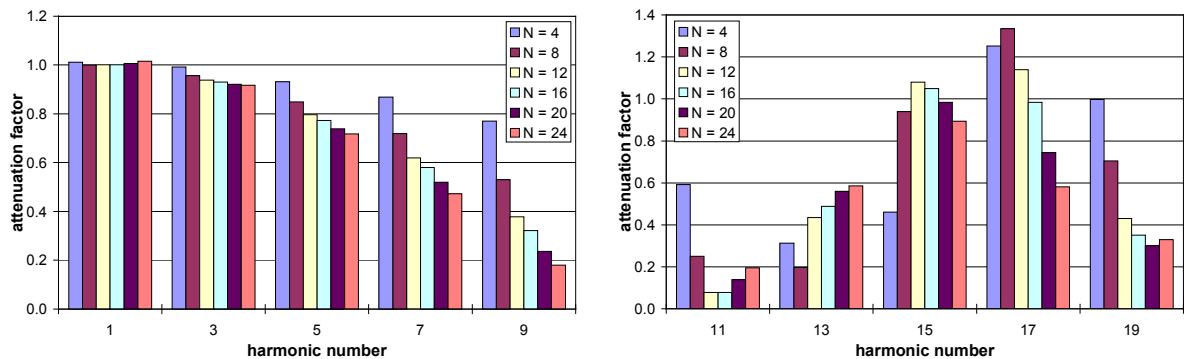

Fig.8. Attenuation factors for harmonic currents (voltage from public distribution network)

4. Conclusions

The cumulative harmonic currents of a large number of non-linear single phase loads, specifically PC's and/or monitors, are analysed, both at a sinusoidal voltage generated by a power source and at the supply voltage of the public distribution system. It is shown that the cumulative current harmonic spectrum of a large number of non-linear single phase loads differs from that of one such load. This is due to the shared series impedance and to the fact that the current finger prints of all loads are not identical.

The third current harmonic increases nearly proportionally with increasing load, while for the higher order current harmonics, there are deviations from the linear relationship becoming more pronounced and even unpredictable with increasing order of the harmonic.

For both set-ups, there is an attenuation of the 5th, 7th and 9th current harmonic that is more pronounced for an increasing load and for higher order harmonics, in correspondence with the simulation results. The attenuation is higher for the set-up where the supply voltage of the public distribution system is used, due to the higher series impedance.

The cumulative behaviour of the higher order harmonics is unpredictable. In the situation with the supply voltage of the public distribution system, some of these harmonics are not attenuated as simulated in [1], but amplified. The presence of a minor harmonic voltage in the power supply has a major effect on current harmonics, more pronounced for higher order harmonics [5].

Acknowledgement

The authors wish to thank the Flemish Government for granting the project "Studie van de nadelige gevolgen van het grootschalig gebruik van verlichting en office-equipment in nutsgebouwen" (IWT-HOBU).

References

- [1] A. Mansoor, W.M. Grady, A.H. Chowdhury, M.J. Samotyj, "An Investigation of Harmonics Attenuation and Diversity Among Distributed Single-Phase Power Electronic Loads," *IEEE Transactions on Power Delivery*, Vol. 10, No. 1, January 1995, pp. 467-473
- [2] T.M. Gruz, "A survey of neutral currents in three-phase computer power systems," *IEEE Transactions on Industry Applications*, Vol. 26, No. 4, July/August 1990, pp. 719-725
- [3] A.-C. Liew, "Excessive neutral currents in three-phase fluorescent lighting circuits," *IEEE Transactions on Industry Applications*, Vol. 25, No. 4, July/August 1989, pp. 776-782
- [4] J. Desmet, I. Sweertvaegher, G. Vanalme and R. Belmans, "On-line monitoring of the neutral conductor current in a three phase supplied network with non-linear load for different power supply and load conditions," *Proc. ERA Conf. on Quality and security of electrical supply*, Oxford, UK, 26-27 February 2001
- [5] J. Desmet, I. Sweertvaegher, G. Vanalme, K. Stockman and R. Belmans, "Analysis of the neutral conductor current in a three phase supplied network with non-linear single phase loads," *Proc IEMDC/IEEE Conf.*, MIT, Cambridge, Massachusetts, USA, 17-21 June 2001
- [6] J. Desmet, I. Sweertvaegher, G. Vanalme, K. Stockman and R. Belmans, "Analysis of electrical and power quality parameters of IT-equipment," *Proc. IASTED International Conference on Power and Energy Systems (EuroPES2001)*, Rhodos, Greece, 3-6 July 2001, pp.280-285
- [7] L. Van der Veken, "Safety and inspection perspective," *European Copper Institute: Workshop on economic cost of poor power quality*, Brussels, Belgium, 8 June 2000
- [8] IEC61000-3-2:2000, *Electromagnetic compatibility (EMC) – Part 3-2: Limits for harmonic current emissions (equipment input current ≤ 16 A per phase)*