

FPGA based digital signal processing for EPR spectroscopy with an application to MRI

Punithavathi Duraiswamy

Department of Information Technology, Ghent University

Supervisor(s): Jan Vandewege, Johan Bauwelinck

Electron Paramagnetic Resonance (EPR), a magnetic resonance technique similar to nuclear magnetic resonance, detects paramagnetic species such as free radicals. Like Magnetic Resonance Imaging (MRI), EPR can be implemented as an imaging technique for small animals and potentially human applications both in pulsed and continuous wave mode. Typical frequencies used for in vivo applications are about 300 MHz with a corresponding static magnetic field of about 100 G (10mT). As demonstrated with high field MRI imaging systems, a frequency of 300 MHz is applicable for clinical use since the penetration depth of this frequency is high enough to image humans. CW EPR techniques are commonly used since they permit detection of paramagnetic species with large width. Building an EPR spectrometer, as shown in Figure 1, is a challenge. The major goal is to have a high sensitivity receiver, which requires special attention to noise, crosstalk from the transmitter, clock jitter, phase noise, power supply filtering, and high speed measurements and processing. In this research, a new measurement method and its processing in FPGA to improve the sensitivity of the system is investigated.

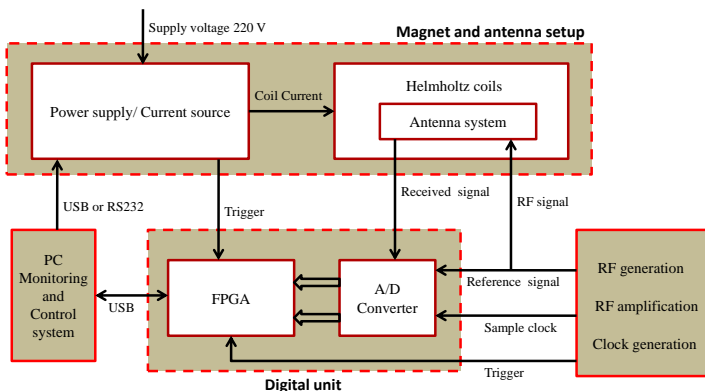

Figure 1. An overview of the EPR spectrometer