



Ghent University  
Faculty of Medicine and Health Sciences  
Department of Internal Medicine  
Nephrology Division

# **Screening for Fabry disease**

## indications, methods and implications

**Wim Terryn**

Thesis submitted in fulfilment of the requirements  
for the degree of Doctor in Medical Sciences  
2013

Promotors:  
prof. dr. Raymond Vanholder  
prof. dr. Bruce Poppe





Faculteit Geneeskunde en Gezondheidswetenschappen  
Departement Interne Geneeskunde  
Divisie Nefrologie

# **Screening voor de Ziekte van Fabry** indicaties, methoden en implicaties

**Wim Terry**

Proefschrift voorgelegd tot het behalen van de graad  
van Doctor in de Medische Wetenschappen  
2013

Promotoren:  
prof. dr. Raymond Vanholder  
prof. dr. Bruce Poppe

## **Promotors**

Prof. dr. Raymond Vanholder  
Ghent University, Faculty of Medicine and Health Sciences  
Department of Internal Medicine, Nephrology Division

Prof. dr. Bruce Poppe  
Ghent University, Faculty of Medicine and Health Sciences  
Center for Medical Genetics

## **Members of the examination committee**

Prof. dr. Elfriede Debaere  
Universiteit Gent, België

Prof. dr. Linda De Meirleir  
Vrije Universiteit Brussel, België

Prof. dr. Olivier Devuyst  
Universität Zürich, Switzerland

Dr. Gabor Linthorst  
Universiteit van Amsterdam, Nederland

Prof. dr. Koen Pameleire  
Universiteit Gent, België

Prof. dr. Rudy Van Coster  
Universiteit Gent, België

Prof. dr. Koen Vandewoude  
Universiteit Gent, België

---

© Wim Terryn

*Screening for Fabry disease: indications, methods and implications / W. Terryn*

*Universiteit Gent, Campus UZ Gent, De Pintelaan 185, 9000 Gent*

*Thesis Universiteit Gent 2013 – with summary in Dutch and French*

*Lay-out, cover & figures: Dirk De Weerd (www.ddwdesign.be)*

# General Table of Contents



<i>Chapter 1</i>	<b>The Place of Fabry Disease among the Sphingolipidoses and Inborn Errors of Metabolism</b>	<b>7</b>
<i>Chapter 2</i>	<b>Screening for Fabry Disease in High-Risk Populations</b>	<b>49</b>
<i>Chapter 3</i>	<b>Attenuated Fabry Disease</b>	<b>85</b>
<i>Chapter 4</i>	<b>Screening and Treatment in Chronic Kidney Disease</b>	<b>99</b>
<i>Chapter 5</i>	<b>General Discussion and Perspectives</b>	<b>123</b>
	<i>Appendix: Population Screening: Problems associated with the detection of atypical or unknown variants and presentation of a possible solution</i>	<b>131</b>
	<i>Summary</i>	<b>137</b>
	<i>Samenvatting</i>	<b>141</b>
	<i>Résumé</i>	<b>145</b>
	<i>Curriculum Vitae</i>	<b>149</b>
	<i>Woorden van dank</i>	<b>153</b>



# *Chapter 1*



## The Place of Fabry Disease among the Sphingolipidoses and Inborn Errors of Metabolism



## **Chapter 1: Contents**

---

**Preface 9**

**Introduction 11**

*Metabolism 11*

*Inborn errors of metabolism: from black urine to gene alterations 11*

*The lysosome is the stomach of the cell 13*

*In lysosomal storage disorders, an enzyme deficiency causes storage of intermediary degradation products 14*

*The clinical presentation of LSDs is extremely variable 16*

*Sphingolipidoses are lysosomal storage disorders caused by accumulation of sphingolipid degradation products 17*

**Fabry disease: Case Study 27**

**A short review on Fabry disease 28**

*Epidemiology 29*

*Clinical description 29*

*Determination of enzyme activity is the gold standard for diagnosis of Fabry disease in males 34*

*In females, mutation analysis should confirm a clinical suspicion of Fabry disease 34*

*Mutation detection and mutation scanning 36*

*Fabry disease has a wide phenotypical spectrum, a low genotype-phenotype correlation and is difficult to recognize 37*

*Conventional medical treatment of Fabry disease 37*

*Enzyme replacement therapy in Fabry disease 38*

*Case study: Discussion 38*

*Conclusion 39*

**Aims and Outlines of this thesis 40**

**References 42**



**PREFACE**

**F**abry disease is a rare X-linked progressive multisystem disorder that belongs to the group of lysosomal storage disorders (LSDs). Signs and symptoms of Fabry disease may be first noted in childhood, such as acroparesthesia, heat intolerance, the inability to sweat and micro-albuminuria. However, because physicians often do not attribute these signs and symptoms to Fabry disease, patients may not be diagnosed until adulthood, when cerebrovascular disease, cardiac hypertrophy and progressive kidney disease can occur. Fabry disease manifests itself not only in males but also in heterozygotes. Heterozygous females show a more variable and in general a more attenuated course. Nonetheless, the mean life expectancy is significantly shortened in both sexes albeit more prominent in males than in females.

The name “Fabry disease” originates from the 19th century. In Fabry patients, angiokeratomas, which are small purplish skin lesions, progressively appear on the skin and were first described in 1898 by two independently working physicians, William Anderson and Johannes Fabry (Figure 1.1.) <sup>1</sup>.

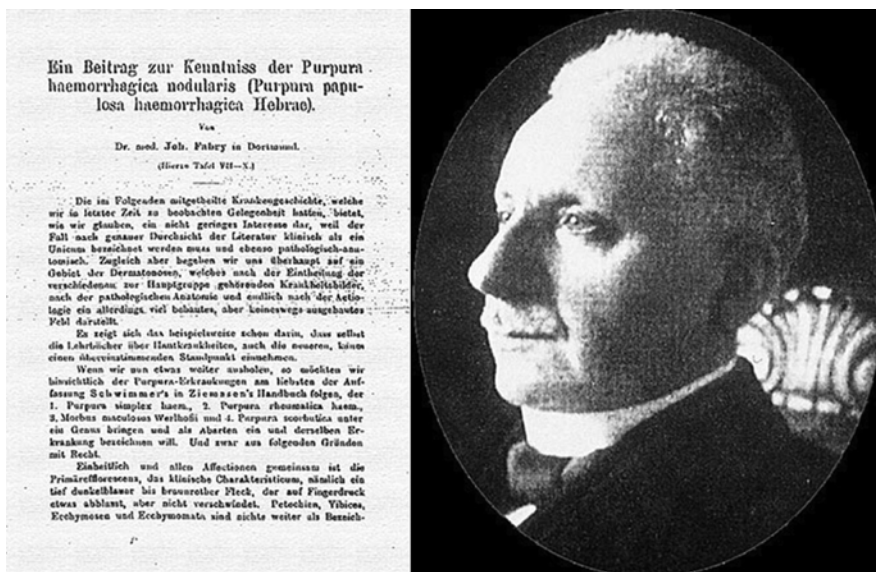

**Figure 1.1.** Johannes Fabry. “Ein beitrag zur Kenntniss der Purpura haemorrhagica nodularis” (Purpura papulosa haemorrhagica Hebrae) 1898.

In the late 1950s and early 1960s, de Duve and colleagues identified the lysosome as a cellular organelle responsible for intracellular digestion and recycling of macromolecules. This was the scientific breakthrough that would lead to the understanding of the physiological basis of the LSDs. Pompe disease was the first disease to be identified as a LSDs in 1963<sup>2</sup>. The deficiency of  $\alpha$ -Galactosidase was first shown to be the enzymatic defect in Fabry disease in 1967 by Brady and colleagues using radiolabelled globotriaosylceramide (Gb-3), which is accumulated in Fabry disease<sup>3</sup>. Subsequently, Kint from the Ghent University demonstrated that  $\alpha$ -Galactosidase could act on the synthetic substrates (p-nitrophenyl- $\alpha$ -d-galactoside and 4-methylumbelliferyl- $\alpha$ -d-galactoside) and was specific for the  $\alpha$ -anomeric galactosidic linkage<sup>4</sup>. This breakthrough eventually facilitated the diagnosis of Fabry disease.

## INTRODUCTION

---

In inborn errors of metabolism (IEMs), a defect in a protein that functions as enzyme, co-factor or transport protein leads to the accumulation or the deficiency of a metabolite. Most of these deficiencies concern one single protein. They can be classified according to the general type of metabolism or the specific cellular organelle that is involved. Classes of IEMs concern the metabolism of amino acids, organic acids, carbohydrates, fatty acids, metals, or are due to deficiencies in lysosomal or peroxisomal enzymes. Most IEMs are very rare, but as a group, they are common. The symptoms of IEMs are extremely diverse, and can be almost any presenting complaint, especially in children, ranging from growth failure and skin rashes to immunodeficiency, vomiting and hyperventilation. Owing primarily to advances in diagnostic technology, a rapidly growing list of IEM presenting in adulthood is emerging. Some of these, e.g. Scheie disease, are caused by milder variants of the same enzyme deficiency that commonly causes death in childhood. Others, such as classical hemochromatosis, almost never present in childhood. Fabry disease belongs to the sphingolipidoses, which are a group of LSDs, where a defective activity of a lysosomal protein results in intra-lysosomal accumulation of undegraded metabolites.

In the first part of this chapter, a short introduction to the IEMs is presented with more details on the sphingolipidoses.

### **Metabolism**

In all cells of living organisms, a set of chemical reactions, called “metabolism” enables growth, reproduction, maintenance of structure, and response to the environment. The term metabolism is derived from the Greek “μεταβολη”, which means “change”: a chemical reaction takes place where substance 1 is being transformed into substance 2, because substance 1 has to be degraded or because substance 2 has to be generated. In multicellular organisms, enzymes mediate a significant number of these chemical reactions. These are large biological molecules that catalyse or increase the rate of the chemical reaction. In case of IEMs, changes in the genes that encode for an enzyme disable the chemical reaction, resulting either in the accumulation of substance 1 or in a deficiency of substance 2. (Figure 1.2.)

### ***Inborn errors of metabolism: from black urine to gene alterations***

Alkaptonuria or “black urine disease” is a key example of how IEMs shaped our current understanding of these rare diseases<sup>5</sup>. It was the first IEM described in 1902 by Sir Archibald Garrod. This disease was much later fully described as the result of a defect in the hepatic enzyme homogentisate 1,2 –deoxygenase (encoded by the *HGD* gene) which participates in the degradation of the amino-acid tyrosine. As a result, a toxic tyrosine degradation product

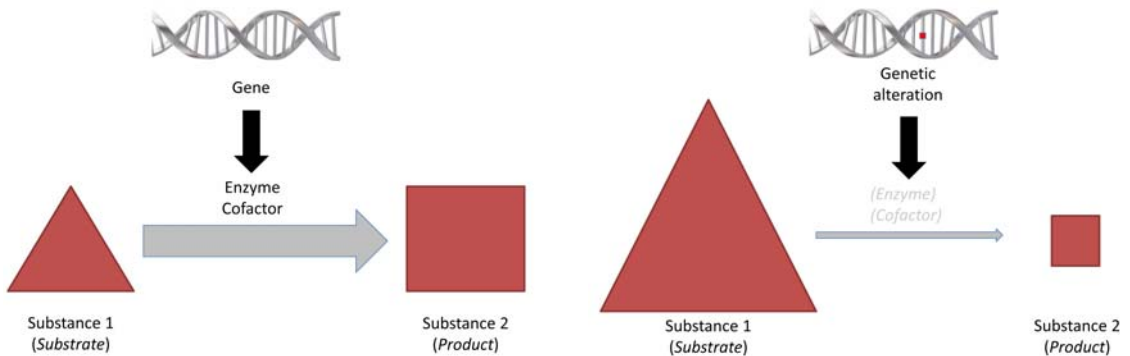

**Figure 1.2.** Inborn errors of metabolism: a mutation in the gene that codes for an enzyme results in the accumulation of substance 1 or the deficiency of substance 2.

homogentisic acid or alkapton accumulates and is excreted in the urine in large quantities. This causes damage to cartilage (resulting in osteoarthritis, especially causing low back pain at young age) and heart valves and precipitates as kidney stones. Homogentisic acid, when exposed to air, colours black staining the sclera and urine of these patients.

Since 1902, hundreds of IEM have been described and can be classified according to the concerning defective metabolic pathway or cellular organelle ,

Presentation is usually in the neonatal period but can occur at any time, even in adulthood. In older children and adolescents, an IEM should be considered in case of subtle neurologic or psychiatric abnormalities. Many of these patients who have been diagnosed with “birth injury”, atypical psychiatric disorders or medical diseases like multiple sclerosis, migraine or stroke may actually have an undiagnosed IEM.

As other IEMs, Fabry disease presents with a myriad of symptoms that frequently present in other diseases but not directly point to an IEM. For this reason, Fabry disease has been called “the new great imposter” <sup>6</sup>. Even psychosis or schizophrenia in adults with typical auditory hallucinations or catatonia can result from IEMs such as Wilson’s disease, Niemann-Pick disease, ureum cycle disorders or acute intermittent porphyria <sup>7</sup>. Inherited metabolic disorders can remain undiagnosed or are misdiagnosed for a number of reasons. Most important is the fact that many physicians are unfamiliar with the symptoms or syndromes of these rare conditions that are excellent keys to the diagnosis. Consequently they do not perform comprehensive examinations but discard signs and symptoms as non-specific or attributable to other conditions. For example, exercise intolerance or fatigue in Fabry disease is frequently attributed to psychological factors, and stroke at young age to a family history of presumed classical atherosclerotic disease.

IEMs individually are very rare but collectively they represent a relatively common group of diseases. In a study in British Columbia <sup>8</sup>, the overall minimum incidence of the metabolic diseases surveyed in children is 40 cases per 100 000 live births, but this is probably an underestimation as not all metabolic diseases have been surveyed; the data do not include

diseases of collagen, such as osteogenesis imperfecta; disorders of metal metabolism, such as Menkes or Wilson's disease; diseases of porphyrin metabolism or any of the blood lipid diseases, such as hypercholesterolemia (other than the LSDs involving glycolipids). As a consequence, we argue that the actual overall incidence is probably much higher.

### ***The lysosome is the stomach of the cell***

An important part of IEMs takes origin in lysosomal enzymes. The lysosome is a cytoplasmic organelle described by the Belgian Christian De Duve <sup>9</sup>who was awarded with the Noble price for this landmark discovery in 1974 (Figure 1.3.) <sup>10</sup>. Lysosomes are present in all eukaryotic cell types except in erythrocytes and can be described as the recycling centres of the cell where macromolecules are degraded for (re) utilisation <sup>11</sup>. This process is achieved in a stepwise manner by removal of terminal residues by a series of lysosomal enzymes, usually hydrolases. The released monomeric units are either transported or diffuse out of the lysosome <sup>12</sup>.

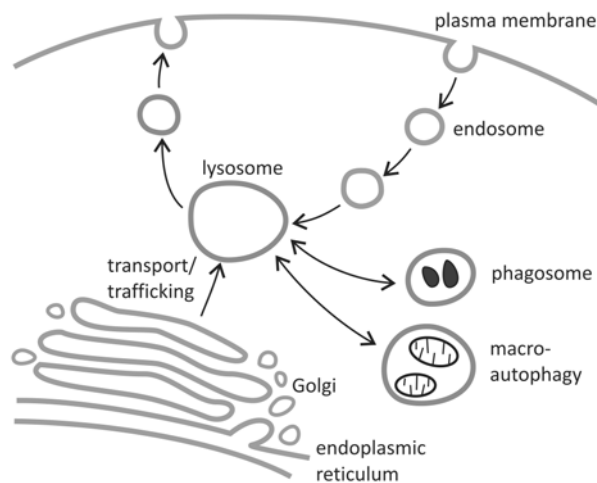

**Figure 1.3.** *The endo-lysosomal pathway.*

*Lysosomes receive substances for degradation via endocytosis: this is invagination and pinching-off of membrane-bound vesicles from the plasma membrane. Through a series of vesicle fusion and fission events involving protein sorting, early endosomes gradually transform into late endosomes, a process called endosomal maturation. mRNA transcripts from genes for lysosomal proteins are translated by ribosomes on the rough endoplasmic reticulum. The nascent peptide chains are translocated into the rough endoplasmic reticulum where they are modified and transported to Golgi. In Golgi, a small molecule, mannose-6-phosphate is added to the peptides. This molecule makes it possible for the peptides to leave the Golgi Apparatus and are ready for trafficking to the lysosome. The lysosome matures, as it becomes more acidic by means of proton pumps making the hydrolases active. The lysosome interacts with endosomes and phagosomes and digests and recycle their macromolecules, or secretes its content.*

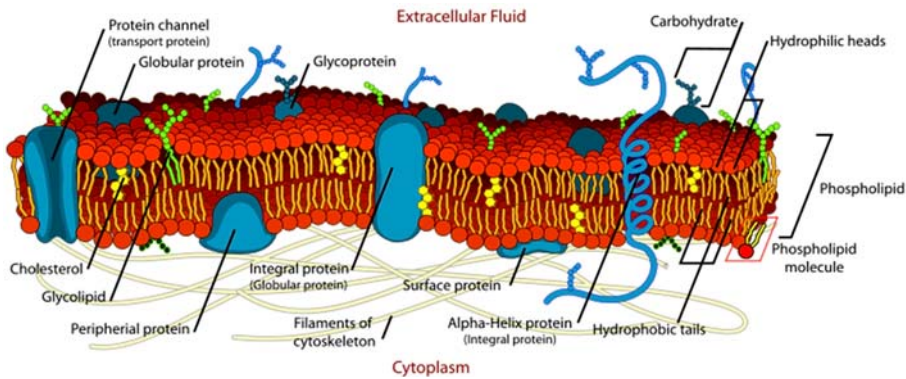

**Figure 1.4.** Glyco(sphingo)lipids are building blocks of eukaryotic membranes.

Glyco(sphingo)lipids are a part of the lipid bi-layer, with carbohydrate chains on the extracellular side of the cell.

The lysosome has a double-layered membrane consisting of phospholipids, integral proteins and a  $\text{Na}^+/\text{K}^+$  ATPase that produces a pH in the lysosome of 4.5. (Figure 1.4.). The inner leaflet of the membrane around the lysosome contains a dense glycocalyx that protects the cell from the degradative effects of lysosomal enzymes<sup>13</sup>. The lysosomal enzymes are active at this acidic pH, and most are soluble and localized in the lysosomal lumen. The macromolecules that are degraded by the lysosomal enzymes come from phagocytosis of viruses and bacteria, autophagy of worn-out mitochondria, endoplasmic reticula or cytoplasmic material, or endocytosis of mycopolysaccharides, lipoproteins and cell remnants. There are estimates that there are at least 50–60 soluble hydrolases and at least 7 integral membrane proteins in lysosomes. Since many of the substrates are complex lipids, which are not water soluble, proteins that function as cofactors or activators are also involved in enzyme-substrate interactions. Other proteins are involved in protecting enzymes from being degraded themselves in this proteolytic environment. A third function of the proteins is the transportation of the degradation products<sup>12</sup>.

In principle, mutations in the genes that encode any of these proteins could cause a LSD. Over 40 LSDs that involve soluble hydrolases are known and recently, a number of diseases have been identified that involve the integral membrane proteins<sup>11,13,14</sup>.

### ***In lysosomal storage disorders, an enzyme deficiency causes storage of intermediary degradation products***

LSDs can be grouped according to various classifications, but perhaps the most useful one is based on characterization of the defective enzyme or protein, rather than on the nature of the accumulated substrate(s) (Table 1.1.)<sup>15</sup>

*Glucosaminoglycans* or *mucopolysaccharides* are long, linear, charged polysaccharides that are composed of a repeating pair of sugars, of which one is an amino sugar. They are accu-

## Fabry disease among the sphingolipidosis and inborn errors of metabolism

**Table 1.1.** Lysosomal storage disorders, adapted from Futerman et al.<sup>15</sup>.

Diseases	Defective protein	Main storage materials
<b>Sphingolipidoses</b>		
Fabry	$\alpha$ -Galactosidase A	Globotriacylceramide and blood-group-B substances
Farber lipogranulomatosis	Ceramidase	Ceramide
Gaucher	$\beta$ -Glucosidase Saposin-C activator	Glucosylceramide
Globoid cell leukodystrophy (Krabbe)	Galactocerebroside $\beta$ -galactosidase	Galactosylceramide
Metachromatic leukodystrophy	Arylsulphatase A Saposin-B activator	Sulphated glycolipids and GM1 ganglioside
Niemann - Pick A and B	Sphingomyelinase	Sphingomyelin
Sphingoipid-activator deficiency	Sphingolipid activator	Glycolipids
GM1 gangliosidosis	$\beta$ -Galactosidase	GM1 ganglioside
GM2 gangliosidosis (Tay-Sachs)	$\beta$ -Hexosaminidase A	GM2 ganglioside and related glycolipids
GM2 gangliosidosis (Sandhoff)	$\beta$ -Hexosaminidase A and B	GM2 ganglioside and related glycolipids
GM2 gangliosidosis (GM2-activator deficiency)	GM2-activator protein	GM2 ganglioside and related glycolipids
<b>Mucopolysaccharidoses (MPS)</b>		
MPS I (Hurler, Scheie, Hurler/Scheie)	$\alpha$ -Iduronidase	Dermatan sulphate and heparan sulphate
MPS II (Hunter)	Iduronate-2-sulphatase	Dermatan sulphate and heparan sulphate
MPS IIIA (Sanfilippo)	Heparan <i>N</i> -sulphatase (sulphamidase)	Heparan sulphate
MPS IIIB (Sanfilippo)	<i>N</i> -Acetyl- $\alpha$ -glucosaminidase	Heparan sulphate
MPS IIIC (Sanfilippo)	Acetyl-CoA: $\alpha$ -glucosamide <i>N</i> -acetyltransferase	Heparan sulphate
MPS IIID (Sanfilippo)	<i>N</i> -Acetylglucosamine-6-sulphatase	Heparan sulphate
Morquio-A disease	<i>N</i> -Acetylgalactosamine-4-sulphatase (arylsulphatase B)	Keratan sulphate, chondroitin-6-sulphate
Morquio-B disease	$\beta$ -Galactosidase	Keratan sulphate
MPS VI (Maroteaux-Lamy)	<i>N</i> -Acetylgalactosamine-4-sulphatase (arylsulphatase B)	Dermatan sulphate
MPS VII (Sly)	$\beta$ -Glucuronidase	Heparan sulphate, dermatan sulphate, chondroitin-4- and -6-sulphates
MPS IX	Hyaluronidase	Hyaluronan
<b>Oligosaccharidoses and glycoproteinoses</b>		
Aspartylglucosaminuria	Aspartylglucosaminidase	Aspartylglucosamine
Fucosidosis	$\alpha$ -Fucosidase	Fucosides and glycolipids
$\alpha$ -Mannosidosis	$\alpha$ -Mannosidase	Mannose-containing oligosaccharides
$\beta$ -Mannosidosis	$\beta$ -Mannosidase	Man( $\beta$ 1 $\rightarrow$ 4)GlcNAc
Glycogen storage disease II (Pompe disease)	$\alpha$ -Glucosidase	Glycogen
Sialidosis	Sialidase	Sialyloligosaccharides and sialylglycopeptides
Schindler disease	$\alpha$ - <i>N</i> -Acetylgalactosaminidase	Glycoconjugates containing $\alpha$ - <i>N</i> -acetylgalactosaminyl
<b>Lipidoses</b>		
Wolman disease and cholesterol-ester storage disease	Acid lipase	Cholesterol esters and triglycerides
<b>Diseases caused by defects in integral membrane proteins</b>		
Cystinosis	Cystinosin	Cystine
Danon disease	LAMP2	Cytoplasmic debris and glycogen
Infantile sialic acid storage disease and Salla disease	Sialin	Sialic acid
Mucopolipidosis (ML) IV	Mucolipin-1	Lipids and acid mucopolysaccharides and lipids
Niemann-Pick C (NPC)	NPC1 and 2	Cholesterol and sphingolipids

mulated in the mucopolysaccharidoses, due to the impaired function of one of the 11 lysosomal enzymes that include exoglycosidases, sulphatases and non-hydrolytic transferases that are required for the sequential degradation of glycosaminoglycans.

In the sphingolipidoses, unmetabolized *sphingolipids* accumulate due to the defective activity of one of a number of enzymes or activator proteins (see further sections).

In the oligosaccharidoses, *oligosaccharides* accumulate.

In some cases, a deficiency in a single enzyme can result in the accumulation of different substrates. For example, GM1 gangliosidosis and Morquio-B disease are both caused by defects in acid  $\beta$ -Galactosidase activity, but they result in GM1 ganglioside and keratansulphate accumulation, respectively, and each disease displays distinct clinical and biochemical features. Similarly, defects in oligosaccharide degradation can result in the accumulation of glycolipids, glycoproteins or proteoglycans<sup>15</sup>.

As a group, the LSDs comprise at least 50 diseases that have a combined incidence of 1 in 5000–7000 live births<sup>16</sup>.

### ***The clinical presentation of LSDs is extremely variable***

At birth, except in case of hydrops fetalis, most newborns with LSDs appear normal, because many of the toxic metabolites cross the placenta during pregnancy and are cleared by the mother during gestation. Hydrops fetalis or congenital ascites may be an earlier manifestation of several different LSDs. The mechanism contributing to the development of hydrops in storage diseases is not fully understood. It may involve the obstruction of venous blood return resulting from organomegaly. It can also result from hypoproteinemia caused by liver dysfunction or from congestive heart failure and liver cirrhosis<sup>16</sup>.

Most LSDs give symptoms in the first months to years after birth, though some can be asymptomatic until late in adulthood. Most often these manifestations include hypotonia or weakness caused by toxic effects of accumulating metabolites in the muscles and central nervous system. Several different LSDs can present with respiratory distress. Other common symptoms are coarse facial features, organomegaly, skeletal dysplasia and skin changes.

LSDs are monogenic (involve only a single gene), but, for most LSDs, extensive allelic heterogeneity has been described: numerous different mutations in the same gene can contribute to the disease. These mutations include missense, nonsense and splice-site mutations, deletions and insertions. Some mutations lead to the complete loss of enzyme activity, whereas others lead to reduced activity. There is no strong genotype–phenotype correlation for most LSDs and prediction of the clinical course of the disease usually cannot be made on the basis of a specific mutation.

Next to the genotype, other factors influence the phenotype in a particular patient. Downstream secondary biochemical and cellular pathways are altered due to substrate accumulation in lysosomes. This is probably important, though is up to now largely unknown.

In many LSDs, severe neuropathology is typical, which leads to death at an early age, whereas in other diseases, the symptoms are mainly restricted to peripheral tissues.



The majority of the LSDs are inherited in an autosomal recessive manner, with three exceptions: the X-linked disorders Fabry disease, Hunter syndrome (mucopolysaccharidosis type II) and Danon disease.

In view of the recessive inheritance pattern, consanguinity is a key factor to consider in diagnosis of neonates from isolated communities. Certain ethnic groups have an increased carrier frequency for specific disorders. For example, Gaucher disease, which results from the deficiency of the enzyme glucocerebrosidase, is the most common genetic disorder in Ashkenazi Jews, with a frequency of ~1 in 855 live births<sup>16</sup>.

The recent development and availability of enzyme-replacement therapy for several of the LSDs makes diagnosis early in the clinical course particularly important. Early diagnosis and intervention is essential for maximizing the potential benefit from some of these therapies and may prevent irreversible organ damage. Early diagnosis can provide parents with realistic information about their child's prognosis and can enable appropriate genetic counselling for future pregnancies. It can also help families avoid the "diagnostic odyssey" that many patients undergo before a diagnosis is made.

### ***Sphingolipidoses are lysosomal storage disorders caused by accumulation of sphingolipid degradation products***

#### **Sphingolipids are building blocks of eukaryotic membranes**

Sphingolipids, together with phospholipids, cholesterol and transmembranous proteins, are building blocks of eukaryotic membranes (Figure 1.3.). Sphingolipids contain a sphingoid base such as sphingosine acylated with a fatty acid (Figure 1.5.). This results in ceramide, which itself is hydrophobic, but it can carry hydrophilic head groups: *phosphorylcholine* in case of sphingomyelin or *oligosaccharide chains*, which are carbohydrate monomers or dimers in case of *cerebrosides* or *globosides* and complex carbohydrates in case of *gangliosides*. These ceramide-oligosaccharide molecules (the cerebrosides, globosides and gangliosides) are called the glycosphingolipids (GSLs). The hydrophilic oligosaccharide chains are located at the extra-cytoplasmic side of the lipid bi-layer of the cell. There is a large variation of glycosphingolipid expression, depending on species and cell type. Neuronal cells are especially rich in acid glycosphingolipids of the ganglio-series. This is the reason why defects in ganglioside degradation affect especially the nervous system<sup>13</sup>.

The *function* of GSLs on the cell surface can be divided into two basic categories. First, they are involved in cell adhesion/recognition processes by interactions with GSLs and lectins (proteins that recognize carbohydrates) on other cells. Second, they modulate signal transduction by influencing receptor proteins on the cell surface. GSLs do not distribute homogeneously in the outer plasma membrane. Together with cholesterol, they form semi-ordered lipid micro-domains, also called "lipid rafts". Certain proteins appear to associate with GSLs in these lipid rafts, such as the epidermal growth factor receptor and the insulin receptor.

### Glycosphingolipids

Example:  $G_{M3}$  ganglioside

NANA - Gal - Glc - Cer

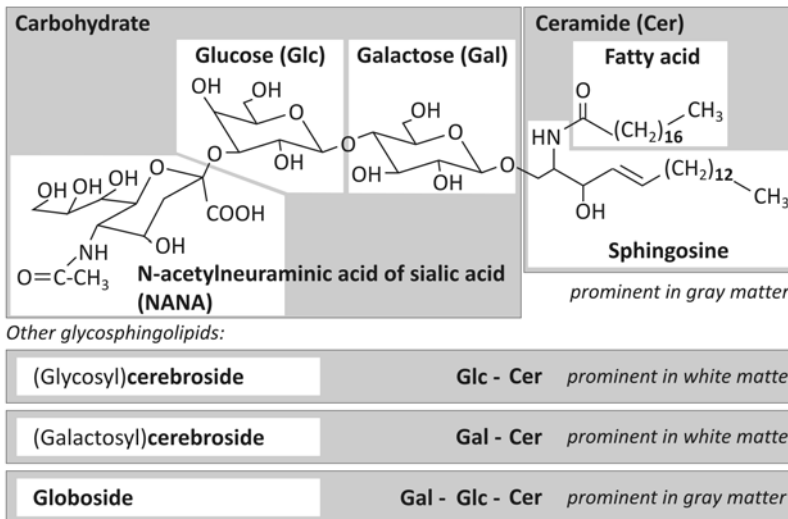

**Figure 1.5.** The structure of glycosphingolipids.

Sphingolipids play important roles in (patho)physiology: some examples:

- Heat shock, oxidative stress, and other damaging conditions induce cells to produce an elevated level of **ceramide**, which has been implicated in signal-transduction pathways that lead to *apoptosis*, and as such have anti-mitogenic effects. This has been used for therapeutic purposes; *vascular stents* have been coated with a ceramide analog and show reduced stenosis <sup>17</sup>.
- **Sphingosine-1-phosphate** is an extracellular ligand for several G-protein-coupled receptors and is involved in many signalling pathways involving cell migration, cell growth, and angiogenesis. In general, sphingosine-1-phosphate has the opposite effect of ceramide, in that it *promotes cell growth and survival*. The balance between sphingosine-1-phosphate and ceramide is called the sphingolipid rheostat <sup>18</sup> and is important in cancer pathogenesis. The acid ceramidase gene that causes Farber disease (a sphingolipidosis) is implicated in prostate cancer: its gene product degrades ceramide and is overexpressed in prostate cancer cells <sup>19</sup>. Drugs that inhibit acid ceramidase have shown to have anti-cancer effects <sup>17</sup>.
- **Sphingosylphosphorylcholine** has been shown to stimulate cell division and has also been implicated in *pro-inflammatory* signalling pathways.
- During embryogenesis and the postnatal period a small subset of acidic **gangliosides** is highly expressed in the developing *brain*. The levels of gangliosides are much lower in the adult brain, but many more different types of gangliosides are expressed. In mouse models, selective deletion of **glycosylceramidesynthase** (GCS) in neural cells prevented

the formation of the brain gangliosides and resulted in the birth of animals with severe neural defects that died within three weeks. Brain gangliosides have also been implicated in several neurological diseases. A lowered GCS activity in the brain tissue of *Alzheimer* patients causes an increase in ceramide and a decrease in the levels of complex GSLs, which in turn may cause abnormal functioning of neural cells. In contrast to this, GM1-enriched membrane micro domains have also been shown to play a critical role in the pathology of Alzheimer disease by promoting the formation of amyloid deposits or plaques by aggregation of amyloid  $\beta$  protein.

- **Ceramides** and **keratins** are the essential components of the *epidermal stratum corneum*, which makes the skin of all land-dwelling animals impermeable to water, thereby preventing lethal dehydration.
- GSLs are found at increased concentrations on the outer membranes of apical cells that line the inside of the stomach, intestines, and respiratory tract. Apical cells represent the initial barrier of the body to the external world and are the first to make contact with potential pathogens. Many pathogens have evolved mechanisms that exploit apical cell surface GSLs to infect and invade their host <sup>20</sup>. For instance, **sialic acids** (= N-Acetylneuraminic acid or NANA) on **gangliosides** serve as parts of the bindings sites for *influenza*. The influenza virus uses neuraminidase, an enzyme that cleaves sialic acid groups from GSLs, to enable release from host cells after replication. The pharmacological inhibition of these enzymes with zanamivir (Relenza®) or oseltamivir (Tamiflu®) is the current basis of influenza treatment.
- **Globotriaosylceramide or Gb-3** is the cell surface receptor for Shiga toxins produced by *E. coli* strains, which are the cause of *hemolytic uremic syndrome*. Genetically engineered mice with targeted disruption of Gb-3 synthase are asymptomatic and insensitive to Shiga toxins. Also the mouse model of Fabry disease is insensitive to Shiga toxin <sup>21</sup>.
- GSLs play an important role in *HIV/AIDS*. The viral envelope gp120 first recognizes its primary receptor on host cells, CD4. This interaction gives rise to a conformational change in gp120 which exposes its third variable loop (V3) which contains a consensus amino acid motif that allows for binding to a trans membrane-spanning chemokine co-receptor (CXCR4 or CCR5, Figure 1.6) <sup>22</sup>. Both interactions are necessary for viral fusion and entry. Apart from binding to this co-receptor, V3 also binds GLSs, especially **Gb-3**, which is normally not expressed on CD4+ T lymphocytes, and could have a protective role in HIV-1 infection. Studies in Fabry disease where Gb-3 accumulates revealed that Fabry disease had a protective effect on the infection of peripheral blood mononuclear cells (PBMCs) by R5 HIV-1. Additional studies assessed the ability of HIV to infect PBMCs from people having a low or high Gb-3 expression. Taken together, these results indicate that over-expressed Gb-3 acts as a natural resistance factor for HIV infection, likely due to its ability to interact with and compete for the chemokine co-receptor binding site within the V3 loop of gp120, thereby preventing interaction of gp120 with the chemokine co-

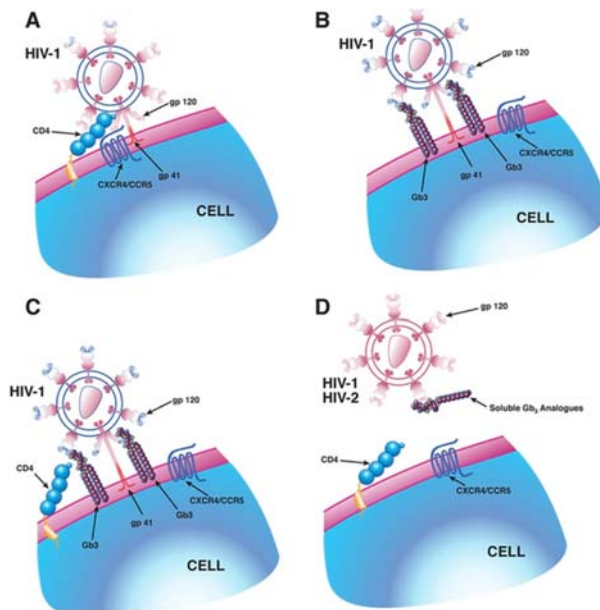

**Figure 1.6.** Interaction of Gb-3 and HIV. (Adapted from Lingwood 21)

A. HIV binds first via gp120 to CD4, causing a conformational change in gp120 and its binding to a chemokine co-receptor (CXCR4 or CCR5), triggering gp41 and cell fusion.

B. CD4-negative cells constitutively express or can be made to overexpress Gb-3, Gb-3 may bind directly to HIV gp120 without HIV binding first CD4. This may result in diminished HIV fusion as the chemokine binding motif is blocked by Gb-3 binding to gp120.

C. If HIV binds to CD4 the binding affinity of Gb-3 to gp120 can be increased to result in an inability for HIV gp120 to bind to a chemokine co-receptor, preventing fusion. Soluble Gb-3 analogue can bind to HIV gp120 independently of CD4 binding and prevent binding to CD4 and/or chemokine co-receptor, preventing HIV infection.

receptor and inhibiting subsequent fusion of HIV to the host cell membrane <sup>22</sup>.

- **Lysosphingolipids** are present in high-density lipoprotein (HDL) and mediate *atheroprotection* via release of nitric oxide, and can also mediate anticoagulation.
- Most tumour cells show altered GSL patterns on their surface as well as abnormal SL signalling and increased GSL biosynthesis, which together play a major role in *tumour growth, angiogenesis, and metastasis*. The human *sialidase Neu3* cleaves terminal Neu5Ac residues from GSLs. It is overexpressed in many types of cancer and plays an important role in tumour growth and survival. Tumour cells also actively shed specific gangliosides from the cell surface to cloak themselves from the body's immune system <sup>20</sup>.
- Fingolimod (Gilenya®, code name FTY720 during the trials) is an oral agent approved for use for the treatment of relapsing forms of *multiple sclerosis* and was originally proposed as an antirejection medication indicated after kidney transplantation. Fingolimod is rapidly converted in vivo to the active moiety S-fingolimod-

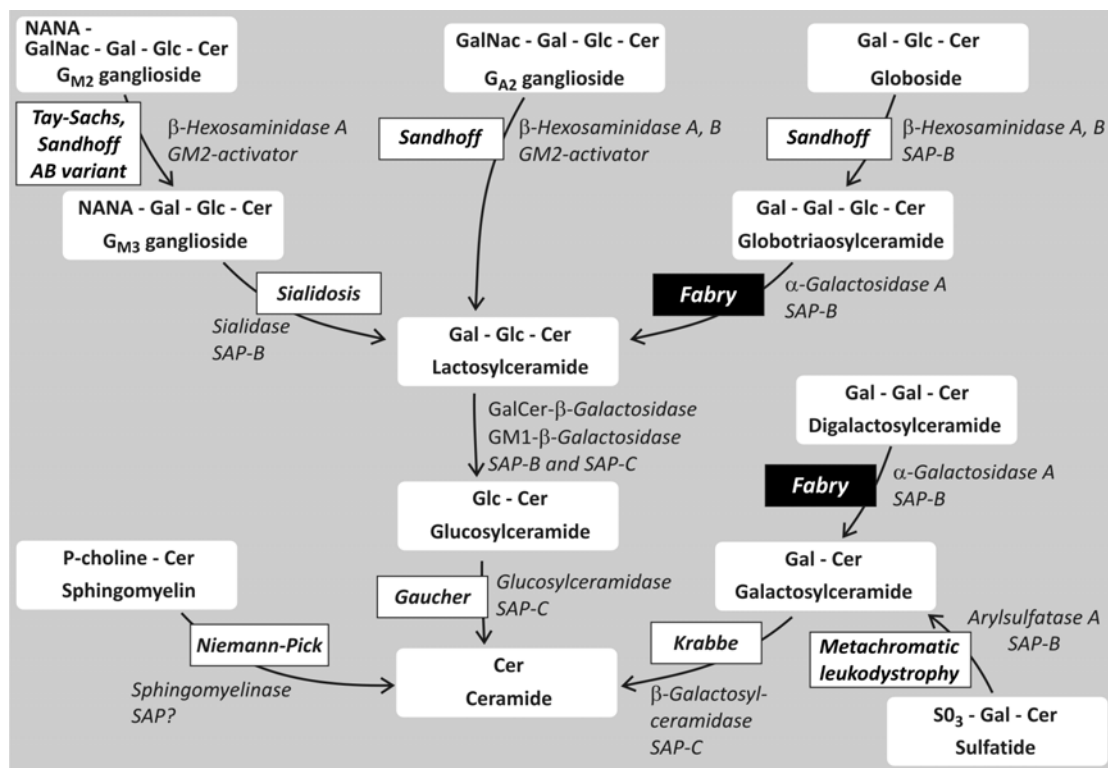

Figure 1.7. Inborn errors of glycosphingolipid metabolism..

phosphate, which binds with high affinity to **Spingosine-1-phosphate (S1P) receptors**, thereby sequestering lymphocytes in the lymph nodes and preventing their egress into the peripheral circulation<sup>17</sup>. As a consequence, there is a reduction in the infiltration of auto-aggressive lymphocytes into the central nervous system or in a transplanted kidney.

### Inborn errors of glycosphingolipid metabolism (Figure 1.7)

Degradation of (glyco)sphingolipids takes place in endosomes and secondary lysosomes. Together with other membrane components, most (glyco)sphingolipids enter the acidic compartment of the lysosome via endocytosis and are cleaved into their building blocks at the surface of intra-endosomal and intra-lysosomal membranes (Figure 1.3.). This requires the presence of hydrolytic enzymes (glycosidases) and co-factors: sphingoid activator proteins (SAP or saposins A to D) and GM2 activator proteins. (Glyco)sphingolipid degradation is a stepwise process and deficiency of one single step causes accumulation of the substrates in the endo-lysosomal compartment. Due to the lipid nature of the storage material, this cannot leave the compartment.

Nutrient delivery through the endolysosomal system can be impaired by a “traffic jam”

caused by storage material. For example, iron homeostasis is impaired in animals with two glycolipid storage diseases, the GM1- and Sandhoff-disease. Supplementation of the animals with iron ions improved their condition and increased their life expectancy by nearly 40%<sup>13</sup>. Another characteristic feature of sphingolipidoses is the accumulation of other lipids as secondary storage products, which arises from the lipid nature of the primary storage compounds that co-precipitate. For example, secondary accumulation of ceramide and the ganglioside GM3 might account for insulin resistance observed in Gaucher disease patients<sup>17</sup>.

With the exception of X-linked Fabry disease, sphingolipidoses are inherited in an autosomal recessive manner. In general, patients display large genotypic and phenotypic heterogeneity: different genotypes can cause similar clinical symptoms, and the outcome of a disease can be different even among patients with identical mutations. The manifestations of the diseases can vary drastically between different sphingolipidoses: while gangliosidoses affect predominantly the grey matter of the brain, Krabbe disease and metachromatic leukodystrophy affect the white matter. Fabry disease is especially a disease of heart and kidney, and Farber disease affects the skin. Also within one and the same disease, broad heterogeneities can be observed. For example, in Gaucher disease, 95% of the patients suffer from the non-neuropathic type 1 without involvement of the nervous system. The other patients have the more severe type 2 with infantile onset or type 3 with juvenile or early adult onset.

### *Diagnosis*

The diagnosis of sphingolipidoses is based on the evaluation of clinical symptoms, characteristic pathological manifestations, analysis of storage compounds, and especially the measurement of enzyme activities. Enzyme sources are serum, leukocytes, cultured skin fibroblasts, amnion cells, chorion villi, or biopsy material. Disease markers like plasma chitotriosidase in Gaucher disease are valuable means for diagnosis and for therapeutic monitoring.

### **Sphingolipidoses are, at least theoretically, treatable**

The theoretical basis for the therapeutic approach is the “threshold theory”<sup>17</sup>. According to this theory, the ratio of substrate influx into the lysosomes and the degradation capacity determines storage and thus the severity of the disease. Both parameters can be addressed by therapeutic approaches, especially since the theory predicts that already slight changes in this ratio can improve the condition of the patient.

The objective of most of the causal therapies is the restoration of the defective degradation capacity within the lysosome by means of enzyme replacement therapy (ERT), cell-mediated therapy including heterologous bone marrow transplantation, gene therapy and enzyme-enhancement therapy with chemical chaperones. An additional strategy for the treatment of sphingolipidoses consists in the reduction of substrate influx into the lysosomes. This can be achieved by substrate reduction (substrate deprivation) therapy.

### *Enzyme replacement therapy*

Lysosomal enzymes have the unique characteristic that, although most of the expressed enzyme is targeted to the endosomal system via binding of the enzyme to the mannose 6-phosphate receptor, a small percentage of expressed enzyme is also *secreted* from the cell, which can be taken up by distal cells and trafficked to the lysosome. Current ERT and bone marrow transplantation therapies take advantage of this process of uptake of secreted enzyme, which is also known as cross-correction<sup>23</sup>. The result of this is a (partial) reduction in substrate storage by the exogenous supply of the defective lysosomal enzyme. The enzymes in ERT are targeted for uptake by the mannose-6-phosphate receptor system, present in nearly all cells, or the mannose receptor, present in cells of the macrophage lineage. ERT is effective in depleting the storage in visceral organs in some LSDs such as non-neuropathic Gaucher disease and Fabry disease, but not for most LSDs that involve the central nervous system, since systemically administered enzyme cannot cross the blood-brain barrier. For delivery to the central nervous system, intrathecal routes of administration have been explored in Gaucher disease, mucopolysaccharidosis type 1 and other LSDs, in animal models as well as in human, with partial success<sup>24</sup>.

### *Cell-mediated therapy*

After allogeneic bone marrow transplantation, donor cells could partially replace for the defective cell population, so that cells with normal enzyme activity would compensate for the defective cells as enzymes are secreted for uptake by deficient cells (*cross correction*).

Over 500 patients with lysosomal and peroxisomal metabolic storage diseases due to deficiency of primary enzymes have been treated with hematopoietic stem cell transplantation. One example is Hurler disease where the enzymatic leukocyte deficiency of  $\alpha$ -L-iduronidase has been totally corrected and has remained at normal levels, with great clinical benefit and spectacular amelioration of neurocognitive functioning<sup>25</sup>.

### *Gene therapy*

Gene therapy aims at restoring gene function by insertion of a functional copy of the mutated gene into cells.

The transfected gene should be stably expressed by a few cells, which might correct the phenotype of adjacent cells via cross-correction. To date, most gene therapy-mediated cross-correction strategies have targeted the liver as the production depot of therapeutic protein as hepatocytes normally synthesize and secrete many different proteins. Another way to deliver cells to the body who stably express the deficient enzyme is the transduction of autologous bone marrow or hematopoietic stem cells with a gene therapy vector to express the therapeutic protein and are then introduced into the affected individual<sup>23</sup>.

Despite the successes of cross-correction-based strategies, for both gene therapy and ERT, these strategies cannot overcome the blood-brain barrier, leaving the neuropathological problems untreated. One problem is the relative inefficiency of the secretion – reuptake



mechanism in comparison with the primary pathway of intracellular production of lysosomal proteins, which are processed via the usual pathway. Delivery of gene therapy vectors directly to affected tissue, allowing the deficient cell to produce the therapeutic protein in an autonomous manner is the most straightforward gene therapy strategy. The challenge in direct correction lies in the technical aspect of delivery of the gene e.g. to the central or peripheral nervous system. Animal model studies of LSDs including MPS, Sandhoff disease, metachromatic leukodystrophy and Neumann-Pick showed biochemical and histological correction in the brain and even improvement in behavioural symptoms after injection of a gene therapy vector<sup>14,23</sup>.

Several viral vectors for gene therapy have been used; retroviruses, adenoviruses and adeno-associated viruses. Retroviruses are single-stranded, RNA-containing enveloped viruses. After entry into a cell, the viral genome is reversed-transcribed into DNA that can then integrate into chromosomal DNA. Adenoviruses are naked, double-stranded DNA viruses. Advantages of adenoviral vectors are the ability to infect a broad range of cell types, both dividing and nondividing, and the capacity for large foreign DNA constructs. Furthermore, recombinant adenoviral vectors generally do not integrate into chromosomal DNA and persist as episomal DNA, thereby minimizing the risk of unwanted insertional mutagenesis. Adeno-associated viruses are nonpathogenic, single-stranded DNA-containing parvoviruses, which as retroviruses and adenoviruses have been used successfully in both small and large animal models of several LSDs, including mucopolysaccharidosis, Fabry disease, and Pompe disease. For example, ventricular infusion of a lentivirus expressing  $\beta$ -glucuronidase in the MPS VII mouse resulted in widespread biochemical and histologic normalization of regions within the brain with significant improvement in behavioural performance<sup>23</sup>. In a murine model of Krabbe disease, a recombinant adenovirus encoding for  $\beta$ -galactocerebrosidase was injected into the cerebral ventricle. Improvement in neurological symptoms and a prolonged lifespan were observed<sup>26</sup>. These and other experiments suggest that gene therapy will be effective *for the treatment of LSDs with CNS involvement. Human experiments are* on their way, e.g. in Gaucher disease (NCT00004294). In this study, patients undergo autologous transplantation using peripheral blood stem cells stimulated with filgrastim (Granulocyte-colony stimulating factor) and transduced with a retroviral vector containing the human glucocerebrosidase gene. Patients may receive up to 4 transplants if a deficient glucocerebrosidase level is found in peripheral leukocytes 1 month following transplantation. Results from this study have not yet been published.

*The innate and adaptive immune system has the capability of limiting the success of viral gene transfer. Immune reactions have been noted in individuals to all LSD receiving ERT resulting in hypersensitivity reactions and the production of antibodies against the enzyme, which is a protein that is foreign to the body. This can lead to neutralization of enzyme activity. Antihistamines and/or other immunosuppressive drugs can control these immune responses. A strategy to avoid immune response has been the timing of gene transfer to the neonatal or even the prenatal stage of development. Introduction of foreign proteins at this time could allow for tolerization to the therapeutic product.*



To date, several Phase I/II clinical studies have been initiated for gene therapy-based treatments for LSDs (Table 1.2.)<sup>23,27.</sup>

**Table 1.2.** Phase I/II clinical studies for gene therapy in lysosomal storage disorders.

Lysosomal storage disorder	Approved treatment	Gene therapy clinical trial and viral vector
Fabry disease	ERT (agalsidase $\alpha$ and $\beta$ )	NCT00001234 RV-a-Galactosidase A
Gaucher's disease I	ERT (imiglucerase, velaglucerase $\alpha$ , taliglucerase $\alpha$ ); SRT (miglustat)	NCT00001234 and NCT00004294 RV-glucoocerebrosidase
Gaucher's disease III	ERT (imiglucerase)	
Glycogen storage disease II (Pompe disease)	ERT (aglucoosidase $\alpha$ )	AAV/NCT00976352 rAAV-CMV-GAA
Metachromatic leukodystrophy		NCT01560182 LV-ARSA
Mucopolysaccharidosis I	ERT (laronidase)	
Mucopolysaccharidosis II	ERT (idursulfase)	NCT00004454 RV-iduronate-2-sulfatase
Mucopolysaccharidosis IIIA (Sanfilippo disease)		NCT01474343 rAAV-SGSH and rAAV-SUMF1
Mucopolysaccharidosis IVA	ERT (galsulfase)	
Mucopolysaccharidosis VI	ERT (galsulfase)	
Neuronal Ceroid lipofuscinosis (Batten disease)		NCT00151216, NCT01411985, NCT01161576 rAAV-CUhCLN2
Niemann-Pick C	Hydropropyl- $\beta$ -cyclodextrin; SRT (miglustat)	

### Enzyme-enhancement therapy

Inherited mutations can disrupt native protein folding, thereby producing proteins with misfolded conformations. These misfolded proteins are consequently degraded by endoplasmic reticulum-associated degradation and do not reach the lysosome, although some of them are catalytically partially active. Active-site-specific chaperones are small molecules that act as a folding template in the endoplasmic reticulum to facilitate folding of mutant proteins, thereby accelerating their escape from the endoplasmic reticulum-associated degradation to maintain a higher level of residual enzyme activity. In Fabry disease, many missense mutations result in misfolding of  $\alpha$ -Gal A, and 1-deoxygalactonojirimycin (known as «DGJ») has also been shown to be the most effective active-site-specific chaperone for increasing residual enzyme activity in cultured fibroblasts and lymphoblasts established from Fabry patients with a variety of missense mutations<sup>28</sup>.

In addition to Fabry disease, small molecules capable of specifically rescuing misfolded enzyme proteins have been identified for Gaucher disease, Tay-Sachs and Sandhoff disease and GM1-gangliosidosis<sup>28</sup>.

*Substrate reduction therapy (SRT)*

The pathological accumulation of a substance in the lysosome occurs as long as biosynthesis continues. Using inhibitors of sphingolipid biosynthesis, the influx of substrate into the lysosomes may be reduced. The proof of principle of this approach has been demonstrated in a genetic model: Sandhoff disease is caused by beta-hexosaminidases A and B deficiency. These catabolic enzymes are needed to degrade neuronal membrane components e.g. the ganglioside GM2. Sandhoff mice were crossbred with mice defective in the biosynthetic enzyme GM2- synthase. Though the life span of these animals was much longer, they developed a late-onset neurological disease due to the accumulation of oligosaccharides<sup>20</sup> Miglustat (Zavesca®) has been approved for treatment in type 1 Gaucher disease and Niemann-Pick disease type C. It is a small iminosugar molecule that acts as a competitive inhibitor of the enzyme, glucosylceramide synthase, which catalyses the first committed step in glycosphingolipid synthesis. Miglustat is able to cross the blood–brain barrier and was shown to reduce glycosphingolipid accumulation and cellular pathology in the brain, delay onset of neurological symptoms, and prolong survival during pre-clinical studies<sup>29</sup>. Miglustat was approved for the treatment of progressive neurological manifestations in pediatric and adult patients with NP-C in the European Union in 2009 and has since been approved for this indication in a number of further countries.

## FABRY DISEASE: CASE STUDY

---

In a second part of this chapter, a typical case of Fabry disease is presented that illustrates the variable presenting symptoms, its X-linked inheritance and the fact that its diagnosis is postponed for many years. This is followed by a general review on Fabry disease.

A thirty-nine-year-old woman presented with oscillopsia, depth perception and word-finding problems, talking gibberish, having a numb sensation with paresis of the right arm and coordination problems on the right side. These symptoms resolved gradually over a period of two hours. Afterwards she felt like having a hangover. In her family history, she mentions the death of her mother secondary to breast cancer. Her father was alive and suffered from migraine and hearing impairment. A *second* episode with oscillopsia and balance disturbances occurred during the same year, again for several hours. Magnetic resonance imaging (MRI) of the brain showed no structural cerebral abnormalities. The diagnosis of transient ischemic attacks (TIA) in the cerebral posterior circulation was made and treatment with aspirin was prescribed. At the age of forty-three, a third episode occurred with transient paresis of the right arm for two hours. The patient had not started the treatment with aspirin.

One year later, her 20-year-old nephew (her sister's son) was admitted with fever, headaches and neck pain with extension to the right arm. Clinical examination upon admission revealed some nuchal rigidity but otherwise unremarkable findings. A viral syndrome with meningism was diagnosed. Analysis of the cerebrospinal fluid showed no abnormalities. During further observation he had an acute episode with visual disturbances (having blurred vision and difficulty recognizing faces and reading words). He felt dizzy and had equilibrium problems (ataxia). These symptoms slowly resolved within the next 3 hours. Neurological examination also revealed nystagmus, unilateral hearing loss and tinnitus.

Medical history revealed episodic fever with myalgia besides intermittent important headache, hypohidrosis, fatigue and exercise intolerance. Ophthalmologic examination revealed cornea verticillata, tortuous retinal vessels and lens opacities, supporting the clinical diagnosis of Fabry disease. Cardiac ultrasound showed borderline septal left ventricular hypertrophy (11 mm) but was otherwise unremarkable.  $\alpha$ -galactosidase A ( $\alpha$ -Gal A) activity measured with dried blood spot was undetectable, and sequencing of the *GLA* gene yielded the missense mutation *GLA* c.758C>T (p.Ile253Thr) which was also confirmed in his aunt, who had a normal  $\alpha$ -Gal A activity. At the time of diagnosis of Fabry disease in his aunt who had then reached the age of forty-nine, she already had developed important asymmetric white matter lesions visible on MRI scan of the brain besides concentric left ventricular hypertrophy (septum thickness was 14 mm) associated with diastolic dysfunction.

## A SHORT REVIEW ON FABRY DISEASE

**F**abry disease (OMIM 301500) is an inborn error of metabolism with, caused by absent or deficient activity of lysosomal  $\alpha$ -Gal A<sup>3,4</sup> (Figure 1.8.) This results in progressive accumulation of Gb-3 and to a lesser extent of other related glycosphingolipids in lysosomes and cytoplasm<sup>30</sup> in a variety of cells, including capillary endothelial cells, renal (podocytes, tubular cells, glomerular endothelial, mesangial and interstitial cells), cardiac (cardiomyocytes and fibroblasts) and nerve cells<sup>30</sup>. This process starts in utero<sup>31</sup> although most patients remain clinically asymptomatic during the first years of their life. Gb-3 storage eventually results in cell dysfunction and the development of irreversible tissue damage<sup>32-34</sup>. The first clinical symptoms appear between the ages of 3 and 10, generally a few years later in girls than in boys<sup>35</sup>. With increasing age, progressive damage to vital organ systems develops in both genders leading to organ failure, mainly involving kidneys, heart and brain, resulting in a reduced life expectancy.

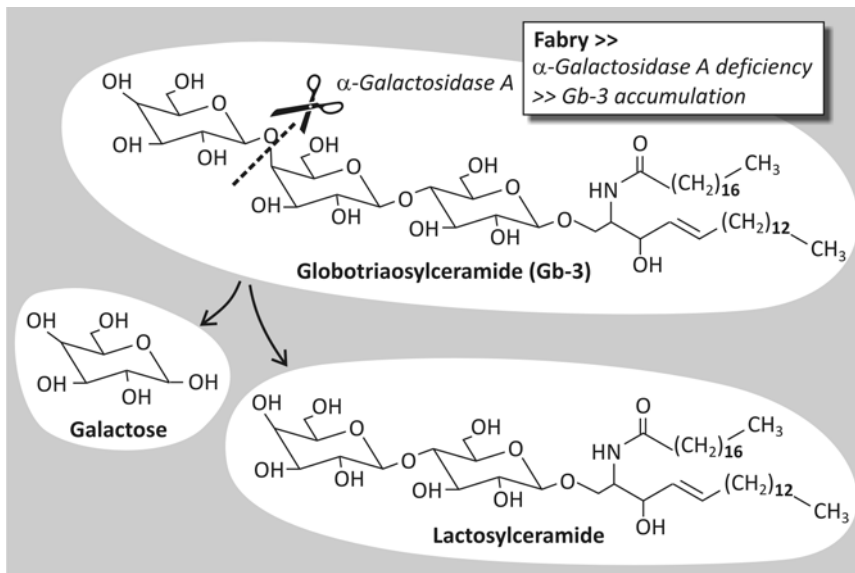

**Figure 1.8.** Fabry disease is caused by  $\alpha$ -Gal A deficiency.

## **Epidemiology**

The prevalence of Fabry disease has been estimated to range between one in 117,000 births and one in 40,000 males (Desnick RJ et al. in <sup>36,37</sup>) but this is probably an underestimation, due to under-diagnosis as a result of the rarity and the complexity of the disease. Screening studies for Fabry disease in high-risk populations (left ventricular hypertrophy, stroke, dialysis) and in newborns yield much higher frequencies <sup>38-41</sup> but this is mainly due to the detection of attenuated (later-onset and milder) phenotypes. In a screening study in Italian newborns, the incidence of  $\alpha$ -Gal A deficiency was 1 in 3,100 with an 11:1 ratio of patients with the later-onset versus classic phenotypes <sup>40</sup>. The other newborn-screening studies showed comparable results (see also Chapter 4).

## **Clinical description**

### **1. Early symptoms: Fabry disease at the pediatric age**

Lysosomal accumulation of Gb-3 begins in utero <sup>31,42</sup> but symptoms can take years to appear. The earliest signs and symptoms can appear in early childhood, beginning a few years earlier in boys compared to girls <sup>35,43</sup>. Neuropathic pain due to accumulation of Gb-3 in small nerve fibers is one of the earliest and most prevalent symptoms in Fabry disease and is experienced in up to 80% of classically affected boys <sup>44,45</sup>. The pain typically presents as acroparesthesia with a burning character. Both acute pain attacks ("Fabry crisis") and chronic background pain have been reported and are a major cause of morbidity during the first two decades of life <sup>44</sup>.

Gastrointestinal involvement is another common manifestation of pediatric Fabry disease <sup>46</sup>. Patients may complain of abdominal pain (often after eating), diarrhoea, nausea, and vomiting, which are a significant cause of anorexia <sup>47</sup>. Despite the high frequency of gastrointestinal symptoms, this does not appear to lead to malabsorption <sup>47</sup>.

Absence or a decreased ability to sweat (an- or hypohidrosis) is a significant problem for patients and can contribute to heat and/or exercise intolerance <sup>48</sup>.

Angiokeratomas are present in 53 % of males and 30 % of female pediatric Fabry patients <sup>45</sup> (Figure 1.9.). These are non-blanching red to blue/black lesions 1 to 5 mm in diameter. They can be unique or appear in groups, first appearing in childhood and increasing during adolescence with lesions on genitals and groin in men, and in the lumbosacral area, gluteal cleft and trunk in both sexes (often in a typical "bathing trunk" distribution). Later in life, angiokeratomas can appear on lips, the umbilicus and palms, but isolated presence in these atypical areas is also possible <sup>49</sup>.

Corneal changes ("cornea verticillata") (Figure 1.10.) detectable by slit lamp examination is present in most children with Fabry disease <sup>50</sup>

Renal intracellular Gb-3 deposits may be present in young children with normal GFR and minimal or absent micro-albuminuria <sup>51</sup>. Podocyte foot process effacement has been re-



**Figure 1.9.** Angiokeratoma (Adapted from Germain 61)

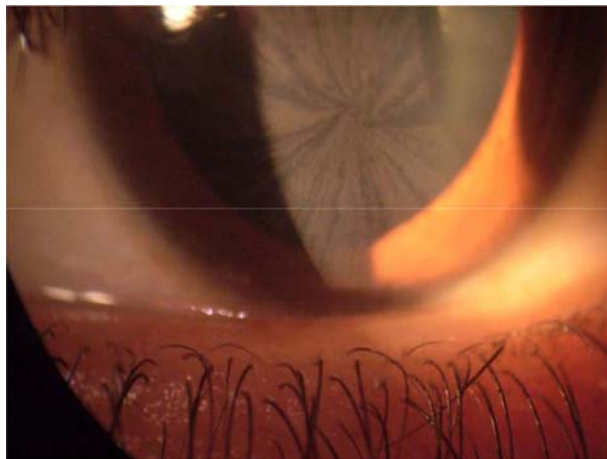

**Figure 1.10.** Cornea Verticillata (Adapted from Germain 61)

ported and albuminuria is one of the cardinal first signs of Fabry nephropathy<sup>52</sup>. Proteinuria progresses and deterioration of kidney function is possible from childhood<sup>35</sup>.

## 2. Kidney involvement

One of the first signs of Fabry nephropathy is micro-albuminuria. At an early stage, hyperfiltration may, as in diabetes, be a first sign of kidney damage. Proteinuria progresses and correlates with and also contributes to the decline in renal function<sup>53,54</sup>. The yearly decline in renal function also correlates with the glomerular filtration rate (GFR) at presentation<sup>53</sup>. In a study of 105 male Fabry patients, mean annual loss of GFR reached 12.2 mL/min/1.73m<sup>2</sup>/year<sup>55</sup>. This is however probably an overestimation as other studies show less rapid deterioration of kidney function. Schiffmann et al.<sup>53</sup> found mean progression rates in males who developed or did not develop end-stage renal disease of -3.85 and -2.93 mL/min/1.73m<sup>2</sup>/year, respectively. Wanner et al.<sup>54</sup> found estimated GFR slopes of -0.2 up to -5.6 mL/min/1.73m<sup>2</sup>/year depending on the amount of proteinuria.

Most patients with CKD stages 3 to 5 have proteinuria<sup>56</sup>. Proteinuria in the nephrotic range (> 3.5 gr/24 h) is rarely seen (maximal 18% in<sup>57</sup>), most often without a full nephrotic syndrome.

CKD stage 5 is found in 50 % of adult male patients (vs. 20% of females) between the third and the fifth decade, with a mean age of 38, but it can be found as early as at the age of 16<sup>58,59</sup>.

## 3. Cardiovascular involvement

In a large study in untreated Fabry patients, 49% of males and 35% of females had a cardiac event at a mean age of 36.2 and 44.4 years, respectively<sup>53</sup>. Cardiac involvement typically presents as a hypertrophic cardiomyopathy, which is typically non-obstructive<sup>60</sup>. As the disease progresses, replacement myocardial fibrosis becomes important<sup>60</sup>. This correlates with observations of relatively mild diastolic dysfunction in early stages of the disease progressing to systolic and diastolic ventricular impairment in the advanced (fibrotic) stage. Patients with Fabry disease may have angina despite angiographic normal coronary arteries. This may be caused by coronary microvascular dysfunction, as it was shown that coronary flow reserve, an index of coronary microvascular function, was diminished<sup>61</sup>. Arrhythmia, including supraventricular, ventricular and brady-arrhythmia is the most common cardiac event, is reported in 42% males and 27% of females<sup>53</sup> and is responsible for a number of cardiac deaths in patients affected with Fabry disease. Arrhythmia arises from Gb-3 accumulation and subsequent ischemia and fibrosis of the sinus node or the conduction system and an imbalance between sympathetic and parasympathetic tone<sup>62</sup>.

Right ventricle involvement is common in Fabry disease and ultimately progresses to severe systolic and diastolic RV dysfunction. These findings might explain why patients with preserved LV function can develop clinical features such as reduced exercise capacity and lymphedema<sup>63</sup>.

Electrocardiographic (ECG) changes in patients with Fabry disease are frequent and show

evidence of LVH and ST-T wave changes<sup>46</sup>. Less frequent abnormalities include a short PR interval (< 0.12 msec)<sup>64</sup> and AV block<sup>65</sup>, for which a permanent pacemaker is implanted in a significant number of patients<sup>60,66</sup>.

#### 4. Cerebrovascular involvement

Besides small fibre neuropathy causing pain, neurologic hallmarks of Fabry disease are cerebral micro- and macro-angiopathy with premature stroke<sup>67</sup>. It has been estimated that during the course of Fabry disease 16% of patients will experience stroke<sup>68</sup>. Cranial MRI shows progressive white matter lesions (WML) at an early age in both genders which are a candidate marker of central nervous system vascular involvement<sup>69</sup>. Furthermore, females seem to be more likely than males to experience stroke as their only Fabry disease clinical event<sup>70</sup> Boston, Mass. 02114, USA. All patients with Fabry disease, regardless of age or gender, should be monitored for possible cerebrovascular complications, as stroke can occur in the absence of other key signs of the disease<sup>70</sup>. Patients with Fabry disease are known to experience stroke at an early age compared to the general population. In the Fabry Registry, median age at first stroke was 39.0 years in males and 45.7 years in females<sup>70</sup>. Stroke is even possible in the first two decades of life<sup>70</sup>.

The distribution of MRI-detectable lesions in the brain is typical of a secondary small-vessel disease, presumably due to a combination of reduced vascular compliance and the activation of pro-thrombotic factors<sup>71</sup>.

Different case studies reported cognitive deficits up to vascular dementia<sup>72,73</sup>. One study examined neuropsychological performance in Fabry disease: mild language and attention deficits but no other cognitive impairment were demonstrated in 17 patients<sup>74</sup>. Depressive syndromes are regarded as the most frequent psychiatric manifestation<sup>73,75</sup>.

#### 5. Other symptoms, quality of life

Patients with Fabry disease have been found to have osteopenia and osteoporosis<sup>76</sup> although this could be secondary to renal failure, malnutrition and low BMI.

Hearing loss and tinnitus are common symptoms in Fabry disease and increase in prevalence with age<sup>77</sup>.

Airway obstruction and reduced diffusion capacity have been reported<sup>78,79</sup>.

Fabry males experience decreased quality of life in physical functioning and bodily pain while general health perception is lowered in females<sup>80</sup>.

Coarsening of facial features is frequent in a number of LSDs<sup>12</sup>. In male Fabry patients, this is most apparent in the peri-orbital region. Peri-orbital fullness with bushy eyebrows, a broad nasal base, shorter and more bulbous nose, fullness of cheeks and a larger chin have been noted<sup>81,82</sup> (Figure 1.11.).

Fabry disease can present with many more symptoms mimicking other diseases (e.g. lymphedema, vertigo, fever, Raynaud, myopathy, etc.)<sup>83,84</sup>, urging some authors to call it "the new great imposter"<sup>6</sup>.





**Figure 1.11.** Facial features in two brothers with AFD and their unaffected sister, showing thickening of the lips and nasolabial folds in the affected males (Adapted from Macdermot<sup>82</sup>).

## 6. Atypical variants

As a result of screening studies during the past decade, clinical variants of Fabry disease have been described. A “cardiac variant” with isolated left ventricular hypertrophy and/or cardiomyopathy presenting in the sixth or seventh decade, lacking the classical disease symptoms and time course was first described<sup>85,86</sup>. Patients suffering from this variant may have proteinuria, but their renal function is typically normal for their age. A “renal variant” phenotype has later been described in a screening study in a dialysis population, where patients again were lacking the classical manifestations, such as acroparesthesia, angiokeratoma, hypohidrosis, or corneal and lenticular lesions. This phenotype was described as “intermediate” between the cardiac variant and the classic phenotype<sup>87</sup>. These patients with cardiac and renal variants lacking the typical disease course starting at a young age are called *atypical or attenuated* Fabry disease patients, to distinguish them from *classical* patients with multi-organ disease and a first presentation at a young age. It is believed<sup>57</sup> that the atypical cases are the result of missense mutations that encode mutant enzyme protein or intronic lesions that reduce transcript levels, both resulting in a reduced but significant residual enzyme function (1-10 % of normal). The residual enzyme function results in attenuation of presenting symptoms<sup>57</sup>.

Heterozygous women, in spite of having a mutation compatible with typical disease, can also present this attenuated phenotype. On the other hand, registry studies show that many females are symptomatic and at considerable risk for major organ involvement and decreased quality of life<sup>88</sup>. In women, there is no good correlation between residual enzyme function and disease severity<sup>89</sup>.

### ***Determination of enzyme activity is the gold standard for diagnosis of Fabry disease in males***

The product of *GLA*, the gene responsible for Fabry disease located at Xq22.1 is  $\alpha$ -Gal A, a lysosomal hydrolase that enzymatically cleaves  $\alpha$ -galactosylresidues from glycosphingolipids (Figure 1.8.). The product of *NAGA*, a gene located at Xq22.13 is  $\alpha$ -N-acetylgalactosidase ( $\alpha$ -NAGA), also called  $\alpha$ -Gal B. It cleaves  $\alpha$ -N-acetylgalactosaminy residues, but also has some activity cleaving  $\alpha$ -galactosylresidues. In order to test for  $\alpha$ -Gal A activity,  $\alpha$ -Gal B has to be inhibited with  $\alpha$ -N-galactosamine. The synthetic fluorogenic substrate, 4-methylumbelliferyl- $\alpha$ -D-glucopyranoside can be used for measurement of Fabry disease in men, with a sensitivity and specificity reaching 100 %<sup>90</sup>. Beta-galactosidase activity is used as an internal standard for evaluation of sample quality.  $\alpha$ -Gal A activity in leucocytes is regarded as the gold standard<sup>90</sup>.

Recently, a dried blood spot test (DBS) using filter paper has been proposed as an alternative being as accurate as the leukocyte tests<sup>91,92</sup>. The samples are easy to transport and are stable at room temperature for many days, making it a most convenient screening tool in men, as it is a very sensitive tool with a negative predictive value reaching 100 %.

### ***In females, mutation analysis should confirm a clinical suspicion of Fabry disease***

In women, enzyme activity measurement has a low sensitivity, as 1 in 3 women with Fabry disease have normal or nearly normal  $\alpha$ -Gal A activity<sup>93</sup>.

One explanation for this lies in a skewed X-inactivation. X-inactivation or lyonisation was described in mice by Mary Lyon in 1961<sup>94</sup>. In mammalian females, one in two X chromosomes are inactivated, and present as heterochromatin, which consists of condensed and transcriptionally inactive DNA. This DNA material can be seen as the "Barr body" in the nucleus of the cell (Figure 1.12.). The purpose of X-inactivation or lyonisation is to prevent female to have a double amount of gene products compared to male. The X inactivation centre (XIC) on the X chromosome contains four RNA genes, one of which is X inactivation specific transcript (Xist). This RNA molecule is not translated into protein, but functions as a cover for the chromosome from which it is derived and silences the X chromosome in case there is not a "blocking" factor from autosomal origin which prevents the transcription of this molecule. As a result, early in the developing female, there is random X chromosome inactivation, but this can be skewed or non-random at the level of a patch, tissue or organ. In Fabry disease, depending on this epigenetic process, there can be significant or even normal  $\alpha$ -Gal A activity in the blood if in a significant amount of cells the wild-type X chromosome is active. At the level of the tissue or organ (brain, kidney or heart), this activity can be very low and the cause of Gb-3 deposition in lysosomes leading to organ damage.

This theory has been debated. In a recent study<sup>95</sup>, the X-chromosome inactivation ratio was determined in 77 samples from Fabry heterozygotes. Only 18.2% were highly skewed (80/20). There were no correlations between the X chromosome inactivation (XCI) ratios and

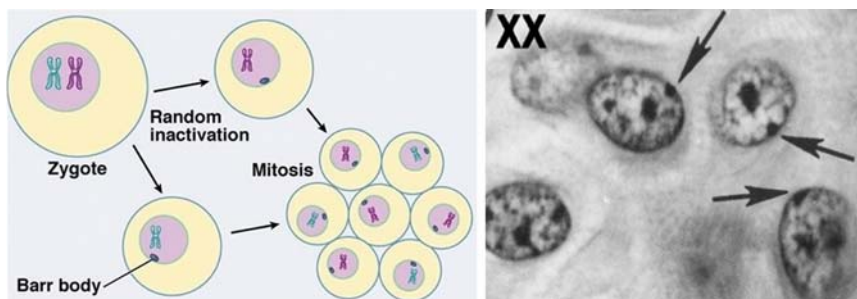

**Figure 1.12.** *X Lyonisation.*

*Random X inactivation happens early in embryonic life, leading to a fixed inactivation in all descending cells.*

age, enzymatic activity of  $\alpha$ -Gal A, Fabry severity scores, or with the clinical signs of cardiac involvement, neuropathic pain, or proteinuria. These findings are essentially the same as seen in normal non-elderly female population, raising the question of the mechanism underlying symptomatic phenotypic expression in heterozygous females with Fabry disease.

Anyway, there is no good correlation between enzyme activity in circulating blood or leucocytes, and disease severity. For this reason, enzymatic tests are less suited and systematic genetic testing should be encouraged in females. In males, mutation analysis is a way of confirming diagnosis, subsequent to enzyme activity measurement. More than 600 mutations have been identified so far (<http://www.hgmd.cf.ac.uk/ac/index.php>, last accessed august 2012).

### **Most exonic and some intronic *GLA* sequence alterations are pathogenic**

Exonic sequence alterations can cause premature stop-codons or frame shift mutations that result in nonsense-mediated decay of mRNA and loss of protein. Exonic sequence changes can also result in a catalytically inactive enzyme, e.g. in case of missense mutations affecting one of the 15 residues in the enzyme active site or one of the 8 cysteine's essential for proper three-dimensional folding of the protein. Intronic mutations can affect evolutionary conserved splice-site dinucleotides at the beginning or the end of the 6 *GLA* introns, interfering with proper splicing of *GLA* mRNA. Two deep-intronic mutations result in complex changes in the patterns of splicing (c.639+861C>T and c.639+919G>A)<sup>90</sup>.

One example of an inert exonic polymorphism (or allelic variants) is the "D313Y" substitution (c.937 G>T). This polymorphism is present in up to 5 % of the population. At neutral pH (plasma), the enzyme activity is very low, while the in the in vitro expression COS 7 cells is 60% of wild type activity, which is enough not lead to Fabry disease. This is now generally considered to be associated with a so-called pseudo-deficiency<sup>96</sup>.

Another (exonic) mutation that is prevalent across populations (p.Asn215Ser) affects intracellular trafficking or packaging and secretion of  $\alpha$ -Gal A, resulting in very low plasma enzyme activity and a slightly higher activity in leucocytes. It is found in several unrelated individuals with the cardiac variant phenotype<sup>86</sup>.

### ***Mutation detection and mutation scanning***

In order to explain a low  $\alpha$ -Gal A activity or a phenotype compatible with Fabry disease, mutation *scanning* can be performed with complete *GLA* gene sequencing in addition to methods for deletion testing (see *infra*).

Once a particular mutation has been found, other often less time consuming methods can be used for mutation *detection*, in order to detect patients and carriers, starting from an index patient.

First, complete gene sequencing can detect different kinds of mutations, e.g. deletions, insertions and point mutations (nonsense, missense or splice site mutations)<sup>97</sup>. These mutations appear *de novo* in an individual in 3 to 10 % of cases<sup>98</sup>. The majority of the mutations are “private”, i.e. unique to a family, and therefore it is always possible to identify a previously undetected mutation. Intronic as well as exonic sequence alterations can be pathogenic (cfr *supra*)<sup>90,99</sup>.

A more economic method for mutation scanning is a targeted mutation analysis. This is the direct detection of one single mutation, e.g. in a family where the mutation has been defined or a population where a mutation is highly prevalent such as *GLA* c.427G>C in Canada (also known as the Nova Scotia mutation). This mutation has a very high prevalence (50 in 178 Fabry patients in the Canadian registry)<sup>100</sup> as the result of a founder effect. The founder effect is the loss of genetic variation that occurs when a new population is established by a very small number of individuals from a larger population, in an isolated region such as Nova Scotia in Canada.

Rapid detection of carriers of a specific mutation is possible via allele-specific oligonucleotide testing using a synthetic segment of DNA approximately 20 base pairs in length (an oligonucleotide) that binds to and hence identifies the complementary sequence in a DNA sample without sequencing the entire *GLA* gene. Direct sequencing will miss partial (exonic) deletions or whole-*GLA*-gene deletions, particularly in females. In male, this can be detected by PCR amplification before sequencing, which can suggest deletion of one or more exons, but this will also fail in female. Other methods (deletion testing) have been designed as a solution for this problem. With quantitative PCR, the DNA is amplified and at the same time quantified by means of e.g. fluorescent reporter probes; large deletions will then easily be detected, as they are not amplified. The method for deletion testing in our lab is Multiplex Ligation-dependent Probe Amplification (MLPA)<sup>101</sup>. This is a variation of the multiplex polymerase chain reaction that permits multiple targets to be amplified with only a single primer pair.

For each target DNA sequence, two adjacent probes are designed that contain the for-

ward and reverse primer sequence, respectively. Each probe also contains a universal primer sequence. In addition, one of both probes contains a stuffer sequence of which the length can be varied. The probes are hybridized against the target DNA and subsequently ligated. Only if ligation happened, a functional PCR strand appears, so that amplification only happens if target DNA is present in the sample. Multiple probe pairs are pooled and amplified with the same primer pair.

Resulting amplification products are separated by electrophoresis. Since the forward primer is fluorescently labelled, each amplification product generates a fluorescent peak, which can be detected by a laser. Comparing the peak pattern obtained on a given sample with that obtained on various reference samples, the relative quantity of each amplicon can be determined. This ratio is a measure for the ratio in which the target sequence is present in the sample DNA.

### ***Fabry disease has a wide phenotypical spectrum, a low genotype-phenotype correlation and is difficult to recognize***

Fabry disease is under-ascertained because of its rarity and lack of knowledge by clinicians, but also because of its wide phenotypical spectrum. Hence, the presentation with stroke, left ventricular hypertrophy and renal failure is non-specific, and typical Fabry symptoms like angiokeratoma can be absent or easily overseen. The wide phenotypical spectrum, even within families, is in agreement with a poor genotype-phenotype correlation<sup>102</sup>, and even in males with virtually absent  $\alpha$ -Gal A, the same mutation can result in a very different phenotype<sup>103</sup>. This applies even more to women and makes the recognition of this heritable disease even more difficult. As a result, screening remains an important tool for case finding. Screening individuals has been performed in high-risk populations with dialysis, kidney transplantation, stroke and cardiac left ventricular hypertrophy. Variable frequencies (0 – 4.2 %) have been found largely due to selection bias and differences in screening tools<sup>104</sup>.

Screening has also been performed in newborns<sup>40,41,105,106</sup> (more details in Chapter 4), but this approach is controversial for several reasons.

### ***Conventional medical treatment of Fabry disease***

Fabry disease is a progressive multi-organ disorder. As a consequence, effective management requires a multidisciplinary approach.

Classic symptomatic treatment of neuropathic pain, gastro-intestinal symptoms and hearing impairment is recommended. Most experts recommend anti-platelet therapy with aspirin or clopidogrel for secondary prevention of stroke.

Renal function Fabry disease is often associated with proteinuric chronic kidney disease and arterial hypertension, and can be treated with angiotensin converting enzyme inhibitors (ACEi) or angiotensin receptor blockers (ARB). Many patients with Fabry disease

and renal involvement will require renal replacement therapy. Kidney transplantation has shown acceptable results<sup>107</sup>. Ten years after transplantation, mortality increases quickly in comparison with non-diabetic transplant recipients, probably due to progression of Fabry Disease<sup>108</sup>.

Angina due to endothelial dysfunction with vasospasm and thrombotic events can be treated with ACEi, calcium channel blockers, and anti-platelet drugs. Drugs like amiodarone should be avoided as they may form complexes with cellular phospholipids that cannot be metabolized by lysosomal phospholipases<sup>109</sup>. Beta-blockers should be used cautiously because bradycardia is a frequent problem. Cardiac pacing or implantation of cardioverter defibrillator devices (ICD) is increasingly used in patients with Fabry disease with atrioventricular block or to prevent sudden cardiac death due to sustained ventricular tachycardia and malignant arrhythmia<sup>60,66,110</sup>.

### ***Enzyme replacement therapy in Fabry disease***

Since 2001, two forms of recombinant alfa-galactosidase A have been approved in Europe: agalsidase alfa (Replagal®; Shire Human Genetic Therapies, Boston, MA, USA) and agalsidase beta (Fabrazyme®; Genzyme, Cambridge, MA, USA), both administered as an intravenous infusion every 2 weeks.

From a recent Cochrane review<sup>111</sup>, it appeared that the evidence base in favour of ERT is weak. Five (total N=187) poor quality randomized controlled trials (RCT's) are available. Most RCT's evaluate surrogate endpoints, such as decrease of plasma Gb-3 levels in plasma and tissues and less often evaluate for harder endpoints such as organ dysfunction or mortality. Besides RCT's, open label studies and retrospective analyses have been performed showing that in male Fabry disease patients renal function remained stable under ERT during follow-up periods of up to 24 months<sup>112</sup>, however, in case of CKD stage 3<sup>113</sup> or proteinuria > 1 gr/gr creatinine<sup>114</sup>, renal function has a tendency to deteriorate. In conclusion, at most ERT stabilizes kidney function when it has not yet been damaged by Fabry disease.

In patients with CKD stage 5, ERT can be performed during the hemodialysis session, which does not alter pharmacokinetics<sup>115</sup>.

ERT is effective for neuropathic pain and quality of life<sup>111</sup> and reduces left ventricular size in patients who have an enlarged heart at baseline<sup>116</sup>, but definitive proof of the long term beneficial effects of ERT on the heart are awaited.

ERT does not cross blood-brain barrier, and while on treatment, variable progression of MRI abnormalities has been noted. Its preventive effect for stroke is also still unproven<sup>117</sup>.

### ***Case study: Discussion***

A woman and her nephew presented both with symptoms and signs of TIA at a young age. She had three episodes, but only at the time of diagnosis in her nephew (ten years after her first presentation), she was diagnosed with Fabry disease. At that time, besides progres-

sive white matter lesions visible on MRI of the brain and cardiac left ventricular hypertrophy, she had no serious organ damage, which is in agreement with an attenuated phenotype as it can present in female.

Her nephew presented at a young age with several TIAs, acroparesthesia and fever of unknown origin. The latter is a rare but well-described symptom in Fabry disease<sup>83</sup>. His family history with TIA in his aunt at a young age could have been helpful for reaching the correct diagnosis, but it was the astute ophthalmologist who finally suggested the diagnosis.

Since five years, the male patient has been treated with ERT. The quality of life showed significant amelioration and there has been no event related to Fabry disease.

### **Conclusion**

Fabry disease is a rare inborn error of metabolism with variable clinical presentation whose diagnosis is frequently missed. Clinicians should consider Fabry disease in case of stroke at a young age and pay considerable attention to the family history, as this can suggest the diagnosis.

---

## AIMS AND OUTLINES OF THIS THESIS

---

The origin of my motivation for this research can be found in 2001, when I was treating a 40-year-old man after kidney transplantation. He was diagnosed with Fabry disease as a result of the diagnosis in his mother who died as a hemodialysis patient five years earlier. I was informed that in Flanders at that time, only about 5 patients were diagnosed with Fabry disease compared to over 30 in Wallonia. As I read that prevalence worldwide was at least 1 in 117.000<sup>37</sup>, I wondered if the other 50 patients in Flanders with its population of over 6 million had been missed.

The rarity of the disorder and the variability in its presentation have caused important diagnostic delays<sup>68</sup>. In case of Fabry disease, with the advent of a promising ERT<sup>118,119</sup> approved in 2002 by the Food and Drug administration (FDA), this is all the more undesirable. Patients not only have to suffer the devastating consequences of their unexplained and threatening illness, but also remain devoid of the potential beneficial effects of therapy.

We wanted to understand this disease and we wanted to find and treat these patients.

The *first aim* of our research was to gain more insight in this rare disease. In **Chapter 1** we studied the position of Fabry disease among the IEMs and LSDs. We discussed two cases of classical Fabry disease whose diagnosis was missed initially and we present a review on etiology, prevalence, disease manifestations and treatment.

The *second aim* of this research was to look for undiagnosed cases of Fabry disease in Flanders in order to get insight in its prevalence, as we hypothesized that many cases were undiagnosed. We aimed at developing and optimizing methods and strategies for a timely diagnosis of Fabry disease. Next, we wanted to make a detailed analysis of the phenotype of the mutations we found in Flanders.

We decided to look for cases in high-risk groups: the first group we screened was the hemodialysis population, where patients without a clear-cut diagnosis were screened using a blood spot test for  $\alpha$ -Gal A activity. The kidney transplant population was screened consecutively, and a third high-risk group we examined was the patient group with left ventricular hypertrophy. The result of this research is described in **Chapter 2**.

It became clear that Fabry disease is much more prevalent than was previously assumed, and that the phenotype of Fabry disease is very variable. In Flanders, the *GLA* p.Ala143Thr (c.427G>A) mutation, which was known to present with an attenuated phenotype, had a relatively high prevalence. We did further research on this mutation, and we got serious doubts on its pathogenicity, which has important consequences for further counseling, diagnosis and treatment of these patients and their families. In **Chapter 3**, we describe our findings on this subject.

Next to screening in high-risk groups, we analyzed the results of screening studies in the healthy population. Indeed, screening for Fabry disease in newborns would be the best



vervangen  
door  
"appendix"

method for early detection of Fabry patients, but in our opinion this clearly poses major problems. In ~~Chapter 4~~, we discuss the ethical and medical issues concerning the screening of newborns in Italy, Taiwan and Austria, where the bulk of the *GLA* mutations discovered consisted of attenuated phenotypes. As we have only very few data genotype-phenotype correlation and are not able to predict progression and the effect of ERT, we felt that screening of healthy newborns was ethically unacceptable. In order to overcome these problems, we developed a screening strategy for detecting classic Fabry disease in boys.

4

The experience from this work was further applied to the population with Chronic Kidney Disease (CKD). In ~~Chapter 5~~ we present recommendations for screening for Fabry disease in patients with otherwise unexplained chronic kidney disease and discuss treating options.

5

Finally in ~~Chapter 6~~, a summary and a general discussion is given, and future projects are presented.

---

**REFERENCES**

---

1. Fabry, H. *An historical overview of Fabry disease. J. Inherit. Metab. Dis.* **24 Suppl 2**, 3–7 (2001).
2. Germain, D. P. [Enzyme replacement therapies for lysosomal storage disorders.]. *Med Sci (Paris)* **21**, 77–83 (2005).
3. Brady, R., Gal, A., Bradley, R., Martensson, E. & Warshan, A. Enzymatic Defect in Fabry's Disease — Ceramidetrihexosidase Deficiency. *N. Engl. J. Med.* **276**, 1163–1167 (1967).
4. Kint, J. A. Fabry's disease: alpha-galactosidase deficiency. *Science* **167**, 1268–1269 (1970).
5. Harris, H. Genetical theory and the "inborn errors of metabolism". *Br Med J* **1**, 321–327 (1970).
6. Lidove, O. *et al.* Fabry disease 'The New Great Imposter': results of the French Observatoire in Internal Medicine Departments (FIMeD). *Clinical Genetics* no–no (2011).
7. Recommendations for the diagnosis and management of Niemann-Pick disease type C: An update. **106**, 330–344 (2012).
8. Incidence of inborn errors of metabolism in British Columbia, 1969–1996. **105**, e10 (2000).
9. De Duve, C. & Wattiaux, R. Functions of lysosomes. *Annu. Rev. Physiol.* **28**, 435–492 (1966).
10. Imaging and imagination: understanding the endo-lysosomal system. **129**, 253–266 (2008).
11. Boya, P. Lysosomal function and dysfunction: mechanism and disease. *Antioxid. Redox Signal.* **17**, 766–774 (2012).
12. Wraith, J. E. Lysosomal disorders. *Semin Neonatol* **7**, 75–83 (2002).
13. Kolter, T. & Sandhoff, K. Lysosomal degradation of membrane lipids. *FEBS Lett.* **584**, 1700–1712 (2010).
14. Kolter, T. & Sandhoff, K. Sphingolipid metabolism diseases. *Biochim. Biophys. Acta* **1758**, 2057–2079 (2006).
15. Futerman, A. H. & van Meer, G. The cell biology of lysosomal storage disorders. *Nat. Rev. Mol. Cell Biol.* **5**, 554–565 (2004).
16. Staretz-Chacham, O., Lang, T. C., LaMarca, M. E., Krasnewich, D. & Sidransky, E. Lysosomal storage disorders in the newborn. *Pediatrics* **123**, 1191–1207 (2009).
17. Kolter, T. A view on sphingolipids and disease. *Chem. Phys. Lipids* **164**, 590–606 (2011).
18. Mandala, S. M. *et al.* Sphingoid base 1-phosphate phosphatase: a key regulator of sphingolipid metabolism and stress response. *Proc. Natl. Acad. Sci. U.S.A.* **95**, 150–155 (1998).
19. Seelan, R. S. *et al.* Human acid ceramidase is overexpressed but not mutated in prostate cancer. *Genes Chromosomes Cancer* **29**, 137–146 (2000).
20. Wennekes, T. *et al.* Glycosphingolipids—nature, function, and pharmacological modulation. *Angew. Chem. Int. Ed. Engl.* **48**, 8848–8869 (2009).
21. Psotka, M. A. *et al.* Shiga Toxin 2 Targets the Murine Renal Collecting Duct Epithelium. *Infection and Immunity* **77**, 959–969 (2009).
22. Lingwood, C. A. & Branch, D. R. The role of glycosphingolipids in HIV/AIDS. *Discov Med* **11**, 303–313 (2011).
23. Byrne, B. J., Falk, D. J., Clément, N. & Mah, C. S. Gene therapy approaches for lysosomal storage disease: next-generation treatment. *Hum. Gene Ther.* **23**, 808–815 (2012).

24. Lachmann, R. H. Enzyme replacement therapy for lysosomal storage diseases. *Curr. Opin. Pediatr.* **23**, 588–593 (2011).
25. Krivit, W. Allogeneic stem cell transplantation for the treatment of lysosomal and peroxisomal metabolic diseases. *Springer Semin. Immunopathol.* **26**, 119–132 (2004).
26. Eto, Y., Shen, J.-S., Meng, X.-L. & Ohashi, T. Treatment of lysosomal storage disorders: cell therapy and gene therapy. *J Inherit Metab Dis* **27**, 411–415 (2004).
27. Fan, J.-Q. & Ishii, S. Active-site-specific chaperone therapy for Fabry disease. *FEBS Journal* **274**, 4962–4971 (2007).
28. Fan, J.-Q. & Ishii, S. MINIREVIEW: Active-site-specific chaperone therapy for Fabry disease. *FEBS Journal* **274**, 4962–4971 (2007).
29. Venier, R. E. & Igdoura, S. A. Miglustat as a therapeutic agent: prospects and caveats. *J. Med. Genet.* **49**, 591–597 (2012).
30. Pastores, G. M. & Lien, Y.-H. H. Biochemical and molecular genetic basis of Fabry disease. *J. Am. Soc. Nephrol.* **13 Suppl 2**, S130–3 (2002).
31. Vedder, A. C. *et al.* Manifestations of Fabry disease in placental tissue. *J Inherit Metab Dis* **29**, 106–111 (2006).
32. De Francesco, P. N., Mucci, J. M., Ceci, R., Fossati, C. A. & Rozenfeld, P. A. Higher apoptotic state in Fabry disease peripheral blood mononuclear cells.: effect of globotriaosylceramide. *Molecular Genetics and Metabolism* **104**, 319–324 (2011).
33. Shen, J.-S. *et al.* Globotriaosylceramide induces oxidative stress and up-regulates cell adhesion molecule expression in Fabry disease endothelial cells. *Molecular Genetics and Metabolism* **95**, 163–168 (2008).
34. Biancini, G. B. *et al.* Globotriaosylceramide is correlated with oxidative stress and inflammation in Fabry patients treated with enzyme replacement therapy. *Biochim. Biophys. Acta* **1822**, 226–232 (2012).
35. Hopkin, R. J. *et al.* Characterization of Fabry disease in 352 pediatric patients in the Fabry Registry. *Pediatr. Res.* **64**, 550–555 (2008).
36. Scriver, C. R. *The metabolic and molecular bases of inherited disease.* (McGraw-Hill Companies, 1995).
37. Meikle, P. J., Hopwood, J. J., Clague, A. E. & Carey, W. F. Prevalence of lysosomal storage disorders. *JAMA* **281**, 249–254 (1999).
38. Linthorst, G. E., Hollak, C. E. M., Donker-Koopman, W. E., Strijland, A. & Aerts, J. M. F. G. Enzyme therapy for Fabry disease: neutralizing antibodies toward agalsidase alpha and beta. *Kidney Int* **66**, 1589–1595 (2004).
39. Lin, H.-Y. *et al.* Enzyme assay and clinical assessment in subjects with a Chinese hotspot late-onset Fabry mutation (IVS4 + 919G A). *J Inherit Metab Dis* **33**, 619–624 (2010).
40. Spada, M. *et al.* High incidence of later-onset fabry disease revealed by newborn screening. *Am. J. Hum. Genet.* **79**, 31–40 (2006).
41. Mechtler, T. P. *et al.* Neonatal screening for lysosomal storage disorders: feasibility and incidence from a nationwide study in Austria. *Lancet* **379**, 335–341 (2012).
42. Tsutsumi, O. *et al.* Early prenatal diagnosis of inborn error of metabolism: a case report of a fetus affected with Fabry's disease. *Asia Oceania J Obstet Gynaecol* **11**, 39–45 (1985).
43. Ramaswami, U. *et al.* Fabry disease in children and response to enzyme replacement therapy: results from the Fabry Outcome Survey. *Clinical Genetics* (2011).doi:10.1111/j.1399-0004.2011.01671.x

44. Hoffmann, B., Georg Koch, H., Schweitzer-Krantz, S., Wendel, U. & Mayatepek, E. Deficient  $\alpha$ -galactosidase A activity in plasma but no Fabry disease – a pitfall in diagnosis. *Clinical Chemistry and Laboratory Medicine* **43**, 1276–1277 (2005).
45. Ries, M. & Schiffmann, R. Fabry disease: angiokeratoma, biomarker, and the effect of enzyme replacement therapy on kidney function. *Arch Dermatol* **141**, 904–5; author reply 905–6 (2005).
46. Sheth, K. J. & Thomas, J. P. Electrocardiograms in Fabry's disease. *J Electrocardiol* **15**, 153–156 (1982).
47. Sheth, K. J., Werlin, S. L., Freeman, M. E. & Hodach, A. E. Gastrointestinal structure and function in Fabry's disease. *Am. J. Gastroenterol.* **76**, 246–251 (1981).
48. Orteu, C. H. *et al.* Fabry disease and the skin: data from FOS, the Fabry outcome survey. *Br J Dermatol* **157**, 331–337 (2007).
49. Zampetti, A. *et al.* Angiokeratoma: Decision Making Methodology for the Diagnosis of Fabry Disease. *Br J Dermatol* (2011).doi:10.1111/j.1365-2133.2011.10742.x
50. Ries, M. *et al.* The early clinical phenotype of Fabry disease: a study on 35 European children and adolescents. *Eur. J. Pediatr.* **162**, 767–772 (2003).
51. Najafian, B. *et al.* Progressive podocyte injury and globotriaosylceramide (GL-3) accumulation in young patients with Fabry disease. *Kidney Int* **79**, 663–670 (2010).
52. Tøndel, C., Bostad, L., Hirth, A. & Svarstad, E. Renal Biopsy Findings in Children and Adolescents With Fabry Disease and Minimal Albuminuria. *American Journal of Kidney Diseases* **51**, 767–776 (2008).
53. Schiffmann, R. *et al.* Fabry disease: progression of nephropathy, and prevalence of cardiac and cerebrovascular events before enzyme replacement therapy. *Nephrology Dialysis Transplantation* **24**, 2102–2111 (2009).
54. Wanner, C. *et al.* Prognostic Indicators of Renal Disease Progression in Adults with Fabry Disease: Natural History Data from the Fabry Registry. *Clinical Journal of the American Society of Nephrology* **5**, 2220–2228 (2010).
55. Branton, M. H. *et al.* Natural history of Fabry renal disease: influence of alpha-galactosidase A activity and genetic mutations on clinical course. *Medicine (Baltimore)* **81**, 122–138 (2002).
56. Ortiz, A. *et al.* Nephropathy in males and females with Fabry disease: cross-sectional description of patients before treatment with enzyme replacement therapy. *Nephrology Dialysis Transplantation* **23**, 1600–1607 (2008).
57. Branton, M., Schiffmann, R. & Kopp, J. B. Natural history and treatment of renal involvement in Fabry disease. *J. Am. Soc. Nephrol.* **13 Suppl 2**, S139–43 (2002).
58. Meehan, S. M., Junsanto, T., Rydel, J. J. & Desnick, R. J. Fabry disease: renal involvement limited to podocyte pathology and proteinuria in a septuagenarian cardiac variant. Pathologic and therapeutic implications. *American Journal of Kidney Diseases* **43**, 164–171 (2004).
59. Ortiz, A. *et al.* End-stage renal disease in patients with Fabry disease: natural history data from the Fabry Registry. *Nephrology Dialysis Transplantation* **25**, 769–775 (2010).
60. Linhart, A. *et al.* Cardiac manifestations of Anderson-Fabry disease: results from the international Fabry outcome survey. *European Heart Journal* **28**, 1228–1235 (2007).
61. Elliott, P. M. *et al.* Coronary microvascular dysfunction in male patients with Anderson-Fabry disease and the effect of treatment with alpha galactosidase A. *Heart* **92**, 357–360 (2006).

62. Germain, D. P. Fabry disease. *Orphanet J Rare Dis* **5**, 30 (2010).
63. Kampmann, C. *et al.* The right ventricle in Fabry disease. *Acta Paediatr Suppl* **94**, 15–8; discussion 9–10 (2005).
64. Aryana, A., Fifer, M. A., Ruskin, J. N. & Mela, T. Short PR interval in the absence of preexcitation: a characteristic finding in a patient with Fabry disease. *Pacing Clin Electrophysiol* **31**, 782–783 (2008).
65. Namdar, M. *et al.* PQ Interval in Patients With Fabry Disease. *Am. J. Cardiol.* **105**, 753–756 (2010).
66. Shah, J. S. *et al.* Prevalence and clinical significance of cardiac arrhythmia in Anderson-Fabry disease. *Am. J. Cardiol.* **96**, 842–846 (2005).
67. Fellgiebel, A., Müller, M. J. & Ginsberg, L. CNS manifestations of Fabry's disease. *Lancet Neurol* **5**, 791–795 (2006).
68. Mehta, A. *et al.* Fabry disease defined: baseline clinical manifestations of 366 patients in the Fabry Outcome Survey. *Eur. J. Clin. Invest.* **34**, 236–242 (2004).
69. Fellgiebel, A. *et al.* Diagnostic utility of different MRI and MR angiography measures in Fabry disease. *Neurology* **72**, 63–68 (2009).
70. Sims, K., Politei, J., Banikazemi, M. & Lee, P. Stroke in Fabry disease frequently occurs before diagnosis and in the absence of other clinical events: natural history data from the Fabry Registry. *Stroke* **40**, 788–794 (2009).
71. Rombach, S. M. *et al.* Plasma globotriaosylsphingosine: diagnostic value and relation to clinical manifestations of Fabry disease. *Biochim. Biophys. Acta* **1802**, 741–748 (2010).
72. Mendez, M. F., Stanley, T. M., Medel, N. M., Li, Z. & Tedesco, D. T. The vascular dementia of Fabry's disease. *Dementia and geriatric cognitive disorders* **8**, 252–257 (1997).
73. Grewal, R. P. Psychiatric disorders in patients with Fabry's disease. *Int J Psychiatry Med* **23**, 307–312 (1993).
74. Low, M. *et al.* Neurology of Fabry disease. *Intern Med J* **37**, 436–447 (2007).
75. Crosbie, T. W., Packman, W. & Packman, S. Psychological aspects of patients with Fabry disease. *J Inherit Metab Dis* **32**, 745–753 (2009).
76. Germain, D. P., Benistan, K., Boutouyrie, P. & Mutschler, C. Osteopenia and osteoporosis: previously unrecognized manifestations of Fabry disease. *Clinical Genetics* **68**, 93–95 (2005).
77. Keilmann, A., Hajioff, D., Ramaswami, U. FOS Investigators Ear symptoms in children with Fabry disease: data from the Fabry Outcome Survey. *Orphanet J Rare Dis* **32**, 739–744 (2010).
78. Wang, R. Y., Abe, J. T., Cohen, A. H. & Wilcox, W. R. Enzyme replacement therapy stabilizes obstructive pulmonary Fabry disease associated with respiratory globotriaosylceramide storage. *J Inherit Metab Dis* **31 Suppl 2**, S369–74 (2008).
79. Magage, S. *et al.* Natural history of the respiratory involvement in Anderson-Fabry disease. *J Inherit Metab Dis* **30**, 790–799 (2007).
80. Bouwman, M. G. *et al.* Impact of growing up with Fabry disease on achievement of psychosocial milestones and quality of life. *Molecular Genetics and Metabolism* **104**, 308–313 (2011).
81. Cox-Brinkman, J. *et al.* Three-dimensional face shape in Fabry disease. *Eur J Hum Genet* **15**, 535–542 (2007).
82. MacDermot, K. D., Holmes, A. & Miners, A. H. Anderson-Fabry disease: clinical manifestations and impact of disease in a cohort of 60 obligate carrier females. *J. Med. Genet.* **38**, 769–775 (2001).

83. Chao, C.-T., Yang, C.-C. & Kao, T.-W. Fabry disease: a rare cause of Fever of unknown origin. *Am. J. Kidney Dis.* **59**, 161–162 (2012).
84. Chimenti, C. *et al.* Cardiac and skeletal myopathy in Fabry disease: a clinicopathologic correlative study. *Hum Pathol* (2012).doi:10.1016/j.humphath.2011.09.020
85. Scheidt, von, W. *et al.* An atypical variant of Fabry's disease with manifestations confined to the myocardium. *N. Engl. J. Med.* **324**, 395–399 (1991).
86. Nakao, S. *et al.* An atypical variant of Fabry's disease in men with left ventricular hypertrophy. *N. Engl. J. Med.* **333**, 288–293 (1995).
87. Nakao, S. *et al.* Fabry disease: detection of undiagnosed hemodialysis patients and identification of a 'renal variant' phenotype. *Kidney Int* **64**, 801–807 (2003).
88. Wilcox, W. R. *et al.* Females with Fabry disease frequently have major organ involvement: lessons from the Fabry Registry. *Molecular Genetics and Metabolism* **93**, 112–128 (2008).
89. Mehta, A., Beck, M., Sunder-Plassmann, G., Ries, M. & Gal, A. *Genotype–phenotype correlation in Fabry disease*. (Oxford PharmaGenesis: Oxford, 2006).
90. Gal, A., Hughes, D. A. & Winchester, B. Toward a consensus in the laboratory diagnostics of Fabry disease - recommendations of a European expert group. *J Inherit Metab Dis* **34**, 509–514 (2011).
91. Olivova, P. *et al.* Effect of sample collection on  $\alpha$ -galactosidase A enzyme activity measurements in dried blood spots on filter paper. *Clinica Chimica Acta* **403**, 159–162 (2009).
92. Reuser, A. J. *et al.* The use of dried blood spot samples in the diagnosis of lysosomal storage disorders - current status and perspectives. *Molecular Genetics and Metabolism* **104**, 144–148 (2011).
93. Linthorst, G. E., Vedder, A. C., Aerts, J. M. F. G. & Hollak, C. E. M. Screening for Fabry disease using whole blood spots fails to identify one-third of female carriers. *Clin. Chim. Acta* **353**, 201–203 (2005).
94. Gene action in the X-chromosome of the mouse (*Mus musculus* L.). **190**, 372–373 (1961).
95. Elstein, D., Schachamov, E., Beerli, R. & Altarescu, G. X-inactivation in Fabry disease. *Gene* **505**, 266–268 (2012).
96. Froissart, R., Guffon, N., Vanier, M. T., Desnick, R. J. & Maire, I. Fabry disease: D313Y is an alpha-galactosidase A sequence variant that causes pseudodeficient activity in plasma. *Molecular Genetics and Metabolism* **80**, 307–314 (2003).
97. Elstein, D., Altarescu, G. & Beck, M. *Fabry Disease*. (Springer Verlag, 2010).
98. *Fabry Disease*. (University of Washington, Seattle, 1993).at <<http://eutils.ncbi.nlm.nih.gov/entrez/eutils/elink.fcgi?dbfrom=pubmed&id=20301469&retmode=ref&cmd=prlinks>>
99. Mignani, R. & Morrone, A. Is standard *GLA* gene mutation analysis definitive for the diagnosis of Fabry disease? *Kidney Int* **75**, 1115–6; author reply 1115 (2009).
100. Sirrs, S. *et al.* Baseline characteristics of patients enrolled in the Canadian Fabry Disease Initiative. *Molecular Genetics and Metabolism* **99**, 367–373 (2010).
101. Schirinzi, A. *et al.* Identification of *GLA* gene deletions in Fabry patients by Multiplex Ligation-dependent Probe Amplification (MLPA). *Molecular Genetics and Metabolism* **94**, 382–385 (2008).
102. Eng, C. M., Resnick-Silverman, L. A., Niehaus, D. J., Astrin, K. H. & Desnick, R. J. Nature and frequency of mutations in the alpha-galactosidase A gene that cause Fabry disease. *Am. J. Hum. Genet.* **53**, 1186–1197 (1993).

103. Verovnik, F., Benko, D., Vujkovic, B. & Linthorst, G. E. Remarkable variability in renal disease in a large Slovenian family with Fabry disease. *Eur J Hum Genet* **12**, 678–681 (2004).
104. Linthorst, G. E. *et al.* Screening for Fabry disease in high-risk populations: a systematic review. *J. Med. Genet.* **47**, 217–222 (2010).
105. Hwu, W.-L. *et al.* Newborn screening for Fabry disease in Taiwan reveals a high incidence of the later-onset *GLA* mutation c.936+919G>A (IVS4+919G>A). *Hum. Mutat.* **30**, 1397–1405 (2009).
106. Lin, H.-Y. *et al.* High incidence of the cardiac variant of Fabry disease revealed by newborn screening in the Taiwan Chinese population. *Circ Cardiovasc Genet* **2**, 450–456 (2009).
107. Ojo, A. *et al.* Excellent outcome of renal transplantation in patients with Fabry's disease. *Transplantation* **69**, 2337–2339 (2000).
108. Inderbitzen N, D., Avital, I., Largiader, F., Vogt, B. & Cancidas, D. Kidney Transplantation Improves Survival and Is Indicated in Fabry's Disease. *Transplantation Proceedings* **37**, 4211–4214 (2005).
109. Ikeda, K. *et al.* Drug-induced phospholipidosis is caused by blockade of mannose 6-phosphate receptor-mediated targeting of lysosomal enzymes. *Biochem. Biophys. Res. Commun.* **377**, 268–274 (2008).
110. Pierre-Louis, B., Kumar, A. & Frishman, W. H. Fabry disease: cardiac manifestations and therapeutic options. *Cardiol Rev* **17**, 31–35 (2009).
111. Dib RP, El, P. G. Enzyme replacement therapy for Anderson-Fabry disease. *Cochrane Database of Systematic Reviews*. 1–53 (2011).
112. Warnock, D. G. *et al.* Renal outcomes of agalsidase beta treatment for Fabry disease: role of proteinuria and timing of treatment initiation. *Nephrology Dialysis Transplantation* (2011).doi:10.1093/ndt/gfr420
113. Schiffmann, R. Long-term therapy with agalsidase alfa for Fabry disease: safety and effects on renal function in a home infusion setting. *Nephrology Dialysis Transplantation* **21**, 345–354 (2005).
114. Germain, D. P. *et al.* Sustained, Long-Term Renal Stabilization After 54 Months of Agalsidase beta Therapy in Patients with Fabry Disease. *Journal of the American Society of Nephrology* **18**, 1547–1557 (2007).
115. Pastores, G. M. *et al.* Safety and pharmacokinetics of agalsidase alfa in patients with Fabry disease and end-stage renal disease. *Nephrology Dialysis Transplantation* **22**, 1920–1925 (2007).
116. Mehta, A. *et al.* Enzyme replacement therapy with agalsidase alfa in patients with Fabry's disease: an analysis of registry data. *The Lancet* **374**, 1986–1996 (2009).
117. Sirrs, S. & Alfadhel Enzyme replacement therapy for Fabry disease: some answers but more questions. *TCRM* **69** (2011).
118. Eng, C. M. *et al.* Safety and efficacy of recombinant human alpha-galactosidase A–replacement therapy in Fabry's disease. *N. Engl. J. Med.* **345**, 9–16 (2001).
119. Schiffmann, R. *et al.* Enzyme replacement therapy in Fabry disease: a randomized controlled trial. *JAMA* **285**, 2743–2749 (2001).







## Screening for Fabry Disease in High-Risk Populations

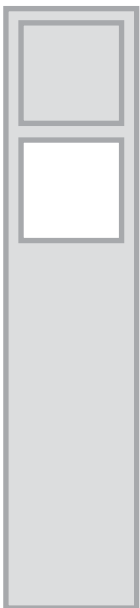

**I**n order to detect index patients and to estimate the prevalence of Fabry disease in Flanders, we screened in total 2135 patients belonging to three high risk-populations: hemodialysis patients, kidney transplant recipients and patients with left ventricular hypertrophy.

## Chapter 2: Contents

---

- Paper One** **49**
- Two-tier approach for the detection of alpha galactosidase A deficiency in a predominantly female haemodialysis population.***
- Terryn W, Poppe B, Wuyts B, Claes K, Maes B, Verbeelen D, Vanholder R, De Boeck K, Lameire N, De Paepe A, De Schoenmakere G.*  
*Nephrol Dial Transplant. 2008 Jan;23(1):294-300.*
- Paper Two** **63**
- Two-tier approach for the detection of alpha-galactosidase A deficiency in kidney transplant recipients.***
- De Schoenmakere G, Poppe B, Wuyts B, Claes K, Cassiman D, Maes B, Verbeelen D, Vanholder R, Kuypers DR, Lameire N, De Paepe A, Terryn W.*  
*Nephrol Dial Transplant. 2008 Dec;23(12):4044-8.*
- Paper Three** **73**
- Prevalence of Fabry disease in a predominantly hypertensive population with left ventricular hypertrophy.***
- Terryn W, Deschoenmakere G, De Keyser J, Meersseman W, Van Biesen W, Wuyts B, Hemelsoet D, Pascale H, De Backer J, De Paepe A, Poppe B, Vanholder R.*  
*Int J Cardiol. 2012 Jul 15. Epub.*

## Paper One

### Two-tier approach for the detection of alpha galactosidase A deficiency in a predominantly female haemodialysis population

*Terryn W, Poppe B, Wuyts B, Claes K, Maes B, Verbeelen D, Vanholder R, De Boeck K, Lameire N, De Paepe A, De Schoenmakere G.  
Nephrol Dial Transplant. 2008 Jan;23(1):294-300.*

#### **Abstract**

**Introduction.** Fabry's disease (AFD) is an X-linked lysosomal storage disease, resulting from a deficiency in alpha-galactosidase A (A-Gal A). Untreated, this leads to precocious failure of vital organ function and death. As enzyme replacement therapy is available, it is of vital importance that affected individuals can be traced.

**Materials and methods.** We set up a screening in the Flemish haemodialysis population using a two-tier approach. The first tier was a determination of alpha-galactosidase A activity using a dried blood spot on filter paper, in the second tier, patients with the lowest alpha-galactosidase levels were further subjected to mutation analysis of the *GLA* gene.

**Results.** 1284 patients (1047 women, 237 men) were evaluated for inclusion, eliminating patients with definite renal diagnoses. Total 922 patients (71.8 %) were screened (742 women, 180 men). Fifty seven patients were subjected to further genetic analysis. Three *GLA* mutation carriers were identified: two apparently nonrelated female patients carry the missense mutation p.Ala143Thr (c.427G > A), a missense mutation p.Trp236Arg (c.706T > C) was identified in a man. While the male patient had been clinically diagnosed with AFD, the female patients had remained unrecognized. Additional family based screening resulted in the identification of nine mutation carriers (four males and five females).

**Discussion.** We demonstrated that the prevalence of *GLA* mutation carriers in our haemodialysis population is 0.3%. Our results show that the proposed approach accurately detects AFD patients. We conclude that screening for AFD in high risk populations is a cost-effective, technically feasible and clinically valuable objective.

## **Introduction**

**F**abry disease (AFD) is an X-linked sphingolipidosis resulting from a quantitative or functional deficiency in alpha-galactosidase A (A-Gal A) [1,2]. Its reported incidence ranges from 1/40 000 to 1/117 000 live births [3,4]. This enzyme defect leads to multiple organ dysfunction; in childhood, the invalidating neuropathic pain predominates. As from the second decade of life, renal, cardiac and neurological symptoms become apparent [4]. Due to its mode of inheritance, all affected males develop clinical symptoms; as a result of skewed lyonisation female carriers can develop the entire spectrum from asymptomatic carriers to classical AFD [5–7].

Several reports indicate that AFD is an underdiagnosed disease entity. This can be attributed to various factors. First, clinical awareness might be low in atypical presentations. In addition, an overrepresentation of female relatives can obscure signs and symptoms in a condition with X-linked inheritance. Finally, the identification of genetic aberrations with a reduced penetration or variant phenotype is anticipated from increasingly sensitive screening analyses.

With the introduction of a safe and efficacious treatment for AFD, the implementation of screening programs in high risk populations seems a clinically relevant objective. Identification of index cases in this setting often leads to detection of affected family members and opens possibilities for early enzyme replacement therapy.

We set up a community-wide screening program in Flemish haemodialysis centres, based on a two-tier approach: initial screening for  $\alpha$ -Gal A deficiency using the dried blood spot technique (DBFP) [22], followed by standard genetic *GLA* gene mutation analysis of the high-risk persons identified in the first part of the study.

## **Materials and methods**

### *Patient selection*

The NBVN (Nederlandstalige Belgische Vereniging voor Nefrologie; a nephrology society grouping all 27 Flemish dialysis centres) database was used for patient selection. This database contains regularly updated diagnostic data on all Flemish haemodialysis patients ( $n = 2828$  at the moment of inclusion), and also specifies the strength of evidence for these diagnostic data. Haemodialysis patients without biopsy-proven renal diagnosis or without evident reason for dialysis requirement (e.g. polycystic kidney disease, bilateral nephrectomy) were considered. Type 2 diabetes was not an exclusion criterion. Both genders were included, however with different age criteria: women older than 18 years (no upper age limit) and men between 18 and 60 years (at the moment of study) were included. In this patient group, one male patient was known to have AFD.

#### *Determination of $\alpha$ -Gal A using the technique of dried blood spot sampled in filter paper*

The screening test was based on a technique of a dried blood spot sampled in filter paper (DBFP) as described by Chamoles et al. [22]. In brief, a standardized disc was punched out of the filter paper and consequently incubated at physiologic pH and at 37°C with 4-methylumbelliferyl-  $\alpha$ -galactopyranoside as substrate. Enzyme activity renders the enzyme product 4-methyl umbelliferone (4-MU), a fluorescent molecule. The fluorescence (excitation, 365 nm; emission, 450 nm) was measured on a Thermo Life Science fluorometer (Thermo Electron Corporation, Waltham, MA-USA). The fluorescence readings were corrected for blanks, and the results were compared with the fluorescence from a 4-methylumbelliferone calibrator. Enzymatic activities were expressed as micromoles of substrate hydrolysed per litre of blood per hour. To validate this technique in our laboratory setting, we performed an analysis of 50 patient samples (non-nephrology, non-ICU, non-haematology, non-paediatric). Results were compared with literature data available. Each DBFP test for  $\alpha$ -Gal A was validated by measurement of  $\beta$ -galactosidase; if no  $\beta$ -galactosidase activity was detectable in the DBFP test, the sample was rejected.

#### *Determination of $\alpha$ -Gal A in white blood cells*

Where appropriate, determination of  $\alpha$ -Gal A levels in white blood cells were determined using the technique previously described by Desnick et al. [23].

#### *Cut-off value for DNA mutation analysis*

Because of the different distribution in the  $\alpha$ -Gal A test results (see later) no cut-off value was used to select which patients could enter the second level of our two-tier screening analysis (mutation analysis). Instead, we performed mutation analysis of the *GLA* gene in patients within the lowest sixth percentile. This value was arbitrarily chosen, taking into consideration the feasibility and costs of the second tier of our protocol.

#### *DNA mutation analysis*

Genomic DNA was extracted from EDTA blood of the patients by standard protocols (PUREGENE DNA purification kit, Gentra) according to manufacturer's instructions. Mutation analysis was performed by PCR amplification followed by direct sequencing of the seven exons and flanking intronic sequences of *GLA* (Genbank: X14448.1- genomic). Primers used were modified from Eng et al. [24].

#### *Informed consent and ethics*

The study protocol was approved by the Ethics committee of the Ghent University Hospital and all patients gave written or oral witnessed consent to participation. The study protocol is in accordance with the Declaration of Helsinki.

## Results

### *Patient selection*

All but one haemodialysis centre participated in the screening study ( $n = 26$ ). From the 2828 patients in the database, 1284 (1047 women, 237 men) were selected after application of the inclusion criteria. Eventually, after informed consent, 922 patients (71.8%) were screened (742 women, 180 men).

### *$\alpha$ -Gal A levels in the control population*

DBFP analysis of the 50 controls yielded a mean  $\alpha$ -Gal A of  $3.17 \pm 1.6$  mmol/l/h (2.5 and 97.5 percentile were 1.62 and 8.39 mmol/l/h, respectively). This is in accordance with literature data showing mean  $\alpha$ -Gal A in healthy males of  $2.93 \pm 1.7$  mmol/l/h (2.5 and 97.5 percentile were 1.37 and 7.66 mmol/l/h, respectively).

### *$\alpha$ -Gal A levels in the screening population*

DBFP analysis of the 922 haemodialysis patients yielded a mean  $\alpha$ -Gal A of  $1.57 \pm 1.5$  mmol/l/h (2.5 and 97.5 percentile were 0.0001 and 5.07 mmol/l/h, respectively). This was significantly lower than the activity in the control group. This difference in  $\alpha$ -Gal A was confirmed by performing a determination of  $\alpha$ -Gal A on white blood cells: in 31 haemodialysis patients the mean enzyme activity was  $3.67 \pm 1.2$  mmol/l/109 WBC (2.5 and 97.5 percentile were 1.37 and 5.77 mmol/l/109 WBC, respectively); in 50 healthy individuals the mean enzyme activity was  $5.43 \pm 2.2$  mmol/l/109 WBC (2.5 and 97.5 percentile were 2.07 and 9.91 mmol/l/109 WBC, respectively) (Figure 2.1). Neither gender nor presence of  $\beta$ -galactosidase had any influence on this difference.

### *DNA mutation analysis*

Fifty-seven patients were subjected to further genetic analysis. Two non-related female patients were found to carry the p.Ala143Thr (c.427G>A) missense mutation, Another missense mutation p.Trp236Arg (c.706T>C) was found in a male patient who was already diagnosed with AFD before the start of the study. Both missense mutations are pathogenic and have been reported previously in AFD patients [25,26].

### *Clinical correlation and family screening*

Index patient 1 (elaborate pedigree is shown in Figure 2.2) was 74 years old on her first admission to the hospital participating in the screening program. She was known to have chronic hypertension and had a creatinine of 87 mmol/l 1 year before admission. On admission, she presented with cardiac angina. At that time, she had nephrotic range proteinuria (11 g/l) and renal insufficiency (creatinine 407 mmol/l). As she refused kidney biopsy, the renal insufficiency was attributed to nephrangiosclerosis and the frequent use of non-steroidal anti-inflammatory drugs. The further work-up revealed she had left ventricular hyper-

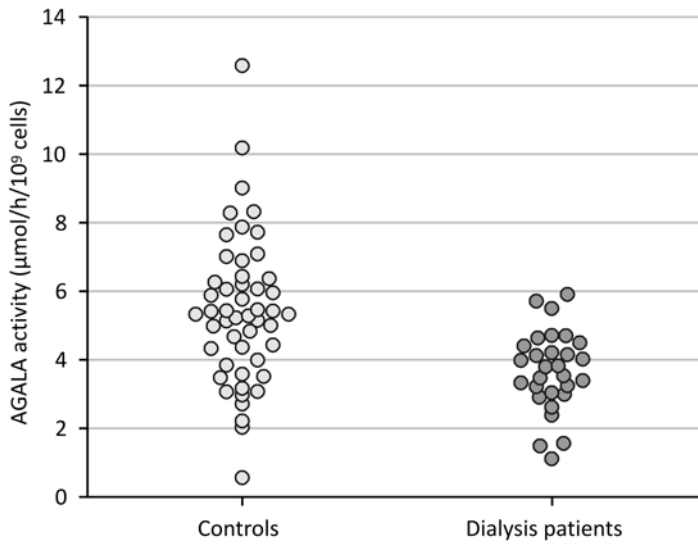

**Figure 2.1.**  $\alpha$ -Gal A activity in WBC in the control population and the dialysis patients.

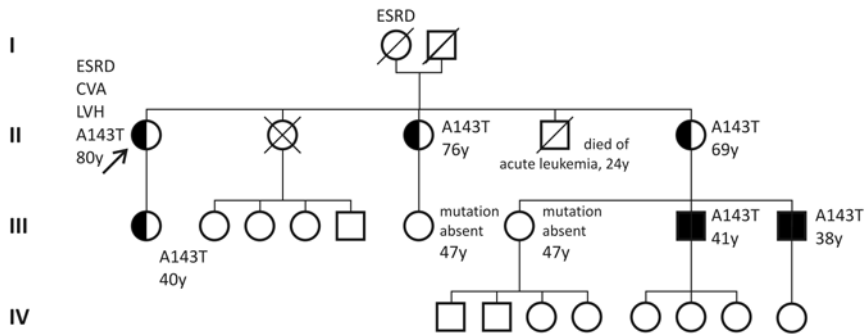
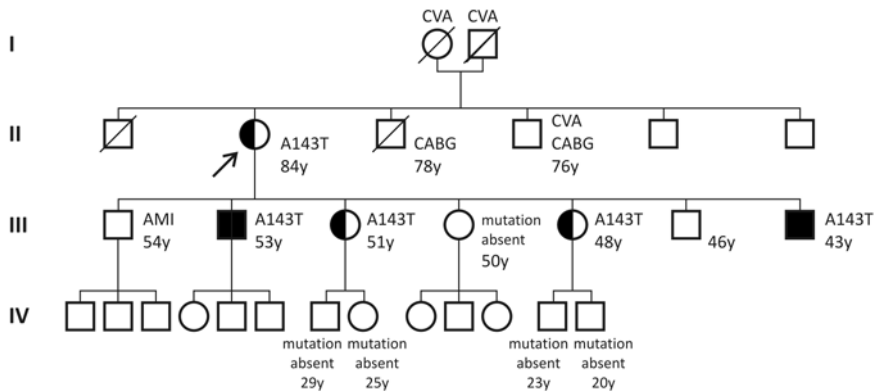

**Figure 2.2.** Pedigree of index patient 1; the index patient is marked by an oblique arrow.

trophy with a septum thickness of 15 mm on the first and 17 mm on the second echocardiography. Also, during hospitalization she developed a homonymous quadrant anopsia with CT imaging suggestive of an ischaemic lesion in the left occipital region. The patient has since been in dialysis (for >5 years now) without major problems. When elaborating the patient's history further, she revealed that after her first pregnancy (still birth), she developed invalidating pain in her lower limbs which, although not completely fitting the description of acroparesthesia, may be related to her underlying condition. The only additional clinical information on this family that is available is the phenotype of the 41-year-old nephew (Figure 2.2). This patient was found to have the mutation, but did not have any clinical sign of AFD: no symptoms, no cardiac and brain MRI abnormalities, normal renal biopsy, no pro-

teinuria, normal renal function, normal echocardiography).

Index patient 2 (elaborate pedigree is shown in Figure 2.3) presented with cardiac angina at the age of 64. A coronarography showed three-vessel disease. At that time, renal function was normal, there was no proteinuria. A coronary arterial bypass grafting (CABG) was performed. Seventeen years later, she was referred again for cardiac angina. Coronarography showed recurrence of coronary ischaemia and aortic valve sclerosis. At that time, creatinine had risen to 168 mmol/l, there was no proteinuria. Imaging revealed she had an atrophic left kidney, and a right renal artery stenosis. The latter was dilated, and she underwent an-



**Figure 2.3.** Pedigree of index patient 2; the index patient is marked by an oblique arrow.

other CABG. The renal insufficiency was attributed to nephroangiosclerosis and ischaemic nephropathy. The renal insufficiency deteriorated, and the patient was started on chronic haemodialysis. Echocardiography performed on multiple occasions never showed left ventricular hypertrophy, nor were there signs of cerebral ischaemia. She died of cardiac arrest during dialysis. It is not clear whether the renal failure in this patient can be attributed to AFD; as the patient did not have proteinuria and taking into account the stenosis of the right renal artery and the atrophic left kidney, an alternative aetiology (renal ischaemia and vascular kidney disease) seems at least as likely. No additional clinical information is available on the other affected family members.

The third index patient had already been diagnosed with Fabry disease before the screening project, and had classical AFD.

Overall we screened 17 relatives of the two newly found index patients, which resulted in the identification of four male hemizygotes and five female heterozygotes (Figures 2.2 and 2.3). Clinical evaluation and therapeutic counselling is ongoing and will be reported elsewhere.



## Discussion

A screening programme for a rare genetic disease is time-consuming and expensive. Therefore, some prerequisites are indispensable: confinement of the screening to a well-defined population subgroup with a higher risk for the presence of the disease, the availability of a cheap and sensitive test method and the possibility to offer therapeutic and genetic counselling after a diagnosis is made [27].

Given the incidence data reported in literature [3,4], the number of patients carrying a mutation in the *GLA* gene in Flanders ranges from 50 to 150. In end-stage renal disease (haemodialysis subgroup), however, a much higher prevalence has been reported, ranging from 1.17% in Japan (exclusively men) [12], 0.22% in the Netherlands (exclusively men) [11] to 0.16% and 0.20% in Austria and the Czech Republic (both genders) [13,32]. Hence, based on literature data at least four *GLA* mutation carriers should theoretically be present in the Flemish dialysis population (n = 2828).

In the current report, we evaluated the clinical utility and the biochemical and molecular efficacy of a two-tier approach for AFD screening in haemodialysis patients without a definite renal diagnosis. It should be pointed out that excluding patients with a biopsy-proven renal diagnosis, leaves the possibility that some of the renal pathologists reading the biopsies might have overlooked the possibility of AFD.

We took advantage of the well-documented registry of our dialysis society to eliminate patients with a biopsy-proven renal diagnosis from the screening programme. The principle of the two-tier approach in this study was to further narrow down the number of patients using the relatively sensitive DBFP technique and then to submit these selected patients to the golden standard of mutation analysis.

Both genders were included in the screening protocol. Taking into consideration the knowledge on the natural history of Fabry disease [28,29] at the time of the study design, an upper age limit of 60 years in men was adopted. Meanwhile, however, Nakao et al. [12] reported 'renal variants' in older dialysis patients without classical symptoms. Hence, retrospectively, it would have been better to include the older male patient population. In women however, no upper age limit was applied, as skewed lyonisation can cause one organ to be severely affected, whereas other organs can be relatively spared [5]. As a consequence, in the relatively old Flemish haemodialysis population (mean age 68.8 years), more women than men were subjected to our screening protocol. In male haemodialysis patients our study may be underpowered to obtain representative results.

We decided to include and even focus on women in our screening programme, keeping in mind the major limitations of the DBFP test in this patient group.

Linthorst et al. [30] recently demonstrated that one-third of the female carriers are missed using this test method. Currently no cost-effective alternatives can be applied in daily practice. Whereas in men a low  $\alpha$ -Gal A activity is diagnostic for Fabry disease, the only way to make the definite diagnosis in women is through mutation analysis. This is time-consuming and expensive, hence beyond the scope of a screening programme. Given the

poorer sensitivity of our DBFP test in women, we were still able to detect two patients that would not have been detected by excluding them completely from the screening protocol.

The DBFP results in all haemodialysis patients tested were somewhat surprising, as the enzyme activity was significantly lower than the reference value in literature [13,22] and that obtained from our own reference population (these last two were not significantly different). This difference was again confirmed by sampling of  $\alpha$ -Gal A enzyme activity in WBC, both in 50 control samples and 31 samples obtained from haemodialysis patients. This contrasts with literature data: in the Dutch screening study, previously frozen whole blood samples were examined using a similar fluorescence technique. Values obtained were more than 10-fold higher, however excitation and emission spectra were different and no reference values were given [11]. In the Japanese screening study [12], plasma activity was measured using the same fluorescence technique, with resulting values in the range comparable to that of healthy controls. However, no whole blood samples were examined from the screened population. Finally, in the Austrian nationwide screening [13], no data are available on the distribution of enzyme activity in comparison with that of a control population. Our study demonstrated a remarkable and significantly lower enzyme activity in whole blood samples taken from dialysis patients, than in those taken from controls or found in literature data.

We excluded interference of uraemic toxins with our fluorescence method by determining the enzyme activity in WBC, which rendered similar results. Blood samples were taken before dialysis start, before patients had received anticoagulation. Further research in this field is needed to determine which factor is responsible for this decreased enzyme activity in patients on dialysis.

In adopting a two-tier approach in the protocol we tried to reduce the costs of the screening program. The costs of a single blood spot analysis in our centre is 5 euro, hence the first tier of the screening protocol costed 4610 euro. The second tier (genetic analysis) is more costly (300 euro per genetic analysis), but the total number of patients to be examined was reduced by the first tier. The second tier of the screening protocol costed 17 100 euro. Hence, the total screening cost was 21710 euro. Had we ideally screened all male patients by a blood spot analysis and all female patients by a mutation analysis, the cost of our screening study would have amounted to  $(5 \times 180) + (300 \times 742) = 223\,500$  euro, resulting in more than a 10-fold increase in costs. Extrapolating this to all haemodialysis patients, this would have been even more accentuated. We considered our screening methods as the most cost-efficient, taking into account that according to Linthorst et al. we may have missed one third of the female patients and taking into account that we may have missed some older male patients and some patients with a biopsy-proven renal diagnosis.

Our results confirm the performance of the adopted methodology in detecting *GLA* mutations, even in atypical clinical settings. While the male patient carrying the p.Trp236Arg was known with AFD, the p.Ala143Thr, previously reported in later-onset patients (e.g. [31]) and showing a considerable amount of transient expression in lysosomes [26], was detected in female patients, unsuspected of having AFD.

Therefore screening efforts are expected to result in the detection of *GLA* mutations in patients presenting with variable phenotypes, even – as we demonstrated – in those with an attenuated phenotype.

The issue should be raised how not to miss the diagnosis in the future in these patients presenting with a non-classical pattern. In retrospect, in the first index patient some findings might have triggered the diagnosis of AFD; renal failure, left ventricular hypertrophy, cerebral thrombosis, lower limb pain. However, in this setting, the working hypothesis of polyvascular disease was at least as acceptable, keeping in mind the respective incidences of these affections. The second index patient illustrates that AFD may easily be missed, and even be impossible to diagnose, without a screening program.

Clearly, in individual patients it is of pivotal importance to detect the disease as early as possible in its natural course. By then, some useful interventions can still be made to slow down, stabilize, or even reverse the end-organ damage. Given the low incidence of AFD, this will always remain problematical – even more so in patients with attenuated phenotypes. Only well-established population and physician information campaigns can help to improve the awareness of AFD and its symptoms. One step further, it is more rewarding to screen high-risk groups (renal failure, hypertrophic cardiomyopathy, cerebrovascular disease). Steps should be undertaken to implement routine measurements of  $\alpha$ -Gal A in these patients, supported by recommendations in national and international guidelines. As an illustration, in the Flemish ESRD patients, we are planning to perform a measurement of  $\alpha$ -Gal A as a standard procedure when entering our registry. This could give us the opportunity to prospectively detect possible AFD carriers, which is even more useful than the trans-sectional study we performed in this report. Although finding an index patient in this late stage of disease is less advantageous for the patient him/herself, it is certainly useful to detect family members in earlier stages.

AFD leads to vital organ failure and early death if untreated in men [29]. In women, the phenotype is largely dependent on lyonisation and the entire clinical spectrum is possible [5]. Given the multi-system involvement of the disease in adulthood (central nervous system, heart, kidney), and the high costs of lifelong enzyme replacement therapy (ERT), we advocate the centralization of data on the natural history of the disease and on effect of treatment on different organ systems. The two-tier approach – suitable for the current setting – may in the future be substituted by a one-tier approach once high-throughput mutation analysis becomes readily available. In addition, a state-of-the-art treatment should not only focus on ERT alone, but should be holistic in preventing disease progression by delivering basic support when needed. Further steps are taken to extend our present screening programme to transplanted patients and patients on peritoneal dialysis. It might also be considered to screen for AFD in patients with mild to moderate renal function impairment. The diagnosis of AFD in these patients might be even more vital as adequate enzyme replacement therapy and standard supportive measures might stabilize or slow down the progression to end-stage renal disease in this group.

To date the first index patient is not treated by enzyme replacement therapy. This deci-

sion was made by the treating physicians based on her age and moderate phenotype (apart from the renal and cardiac involvement). However, her prominent left ventricular hypertrophy might warrant enzyme treatment. The usefulness and effect of ERT on morbidity and mortality in a dialysis population over 80 have not been substantiated in a large series and opens the discussion on treatment options in this type of patient. As further observational studies will be needed to provide us with the answer to this question, we suggest in the meantime make the decision on ERT initiation based on the clinical patient status and the expected survival on dialysis, even without AFD.

As mentioned, the second index patient died. We have no further information on the treatment of affected family members

## References

1. Brady R, Gal A, Bradley R et al. Enzymatic defect in Fabry's disease. Ceramidetrihexosidase deficiency. *N Engl J Med* 1967; 276: 1163–1167
2. Desnick R, Allen KY, Desnick S et al. Fabry's disease: enzymatic diagnosis of hemizygotas and heterozygotas. Alpha-galactosidase activities in plasma, serum, urine, and leukocytes. *J Lab Clin Med* 1973; 81: 157–171
3. Meikle P, Hopwood J, Clague A, Carey W. Prevalence of lysosomal storage disorders. *JAMA* 1999; 281: 249–254
4. Branton M, Schiffmann R, Sabnis S et al. Natural history of Fabry renal disease: influence of alpha-galactosidase A activity and genetic mutations on clinical course. *Medicine* 2002; 81: 122–138
5. Deegan P, Baehner A, Barba Romero M et al. (European FOS Investigators): Natural history of Fabry disease in females in the Fabry Outcome Survey. *J Med Genet* 2006; 43: 347–352
6. Whybra C, Kampmann C, Willers I et al. Anderson-Fabry disease: clinical manifestations of disease in female heterozygotas. *J Inher Metab Dis* 2001; 24: 715–724
7. Kampmann C, Baehner F, Whybra C et al. Cardiac manifestations of Anderson-Fabry disease in heterozygotas. *J Am Coll Cardiol* 2002; 40: 1668–1674
8. Eng C, Guffon N, Wilcox W et al. (The International Collaborative Fabry Disease Study Group): safety and efficacy of recombinant human  $\alpha$ -galactosidase A replacement therapy in Fabry's disease. *N Engl J Med* 2001; 345: 9–16
9. Schiffmann R, Kopp J, Austin H, III et al. Enzyme replacement therapy in Fabry disease: a randomized controlled trial. *JAMA* 2001; 285: 2743–2749
10. Hauser A, Lorenz M, Voigtlander T, Fodinger M, Sunder-Plassmann G. Results of an ophthalmologic screening programme for identification of cases with Anderson-Fabry disease. *Ophthalmologica* 2004; 218: 207–209
11. Linthorst G, Hollak C, Korevaar J et al. Alpha-Galactosidase A deficiency in Dutch patients on dialysis: a critical appraisal of screening for Fabry disease. *Nephrol Dial Transplant* 2003; 18: 1581–1584
12. Nakao S, Kodama C, Takenaka T et al. Fabry disease: detection of undiagnosed hemodialysis patients and identification of a "renal variant" phenotype. *Kidney Int* 2003; 64: 801–807

13. Kotanko P, Kramar R, Devrnja D et al. Results of a nationwide screening for Anderson-Fabry disease among dialysis patients. *J Am Soc Nephrol* 2004; 15: 1323–1329
14. Ichinose M, Nakayama M, Ohashi T et al. Significance of screening for Fabry disease among male dialysis patients. *Clin Exp Nephrol* 2005; 9: 228–232
15. Tanaka M, Ohashi T, Kobayashi M et al. Identification of Fabry's disease by the screening of alpha-galactosidase A activity in male and female hemodialysis patients. *Clin Nephrol* 2005; 64: 281–287
16. Bekri S, Enica A, Ghafari T et al. Fabry disease in patients with end-stage renal failure: the potential benefits of screening. *Nephron Clin Pract* 2005; 101: c33–c638
17. Nakao S, Takenaka T, Maeda M et al. An atypical variant of Fabry's disease in men with left ventricular hypertrophy. *N Engl J Med* 1995; 333: 288–293
18. Sachdev B, Takenaka T, Teraguchi H et al. Prevalence of Anderson-Fabry disease in male patients with late onset hypertrophic cardiomyopathy. *Circulation* 2002; 105: 1407–1411
19. Chimenti C, Pieroni M, Morgante E et al. Prevalence of Fabry disease in female patients with late-onset hypertrophic cardio- myopathy. *Circulation* 2004; 110: 1047–1053
20. Ommen S, Nishimura R, Edwards W. Fabry disease: a mimic for obstructive hypertrophic cardiomyopathy? *Heart* 2003; 89: 929–930
21. Arad M, Maron B, Gorham J et al. Glycogen storage diseases presenting as hypertrophic cardiomyopathy. *N Engl J Med* 2005; 352: 362–372
22. Chamoles N, Blanco M, Gaggioli D. Fabry disease: enzymatic diagnosis in dried blood spots on filter paper. *Clin Chim Acta* 2001; 308: 195–196
23. Desnick R, Allen K, Desnick S et al. Fabry's disease: enzymatic diagnosis of hemizygotes and heterozygotes: Alpha-galactosidase activities in plasma, serum, urine, and leukocytes. *J Lab Clin Med* 1973; 81: 157–171
24. Eng C, Resnick-Silverman L, Niehaus D, Astrin K, Desnick R. Nature and frequency of mutations in the alpha-galactosidase A gene that cause Fabry disease. *Am J Hum Genet* 1993; 53: 1186–1197
25. Eng C, Ashley G, Burgert T et al. Fabry disease: thirty-five mutations in the alpha-galactosidase A gene in patients with classic and variant phenotypes. *Mol Med* 1997; 3: 174–182
26. Shabbeer J, Yasuda M, Benson S, Desnick R. Fabry disease: identification of 50 novel alpha-galactosidase A mutations causing the classic phenotype and three-dimensional structural analysis of 29 missense mutations. *Hum Genomics* 2006; 2: 297–309
27. Meikle P, Ranieri E, Simonsen H et al. Newborn screening for lysosomal storage disorders: clinical evaluation of a two-tier strategy. *Pediatrics* 2004; 114: 909–916
28. Branton M, Schiffmann R, Sabnis S et al. Fabry renal disease: influence of alpha-galactosidase A activity and genetic mutations on clinical course. *Medicine (Baltimore)* 2002; 81: 122–138
29. Branton M, Schiffmann R, Kopp J. Natural history and treatment of renal involvement in Fabry disease. *J Am Soc Nephrol* 2002; 13 [Suppl 2]: S139–S14
30. Linthorst G, Vedder A, Aerts J, Hollak C. Screening for Fabry disease using whole blood spots fails to identify one-third of female carriers. *Clin Chim Acta* 2005; 353: 201–203
31. Spada M, Pagliardini S, Makiko Yasuda M et al. High Incidence of Later-Onset Fabry Disease Revealed by Newborn Screening. *Am J Hum Gen* 2006; 79

32. Merta M, Reiterova J, Ledvinova J et al. A nationwide blood spot screening study for Fabry disease in the Czech Republic haemodialysis patient population. *Nephrol Dial Transplant* 2007;2: 179–186

## Paper Two

### Two-tier approach for the detection of alpha-galactosidase A deficiency in kidney transplant recipients

*De Schoenmakere G, Poppe B, Wuyts B, Claes K, Cassiman D, Maes B, Verbeelen D, Vanholder R, Kuypers DR, Lameire N, De Paepe A, Terryn W. Nephrol Dial Transplant. 2008 Dec;23(12):4044-8*

#### **Abstract**

**Background.** Anderson-Fabry disease (AFD) is an Xlinked condition originating from a deficiency in alphagalactosidase, a lysosomal enzyme. Multi-organ involvement ensues in early adulthood and vital organs are affected: the kidneys, brain, heart. Several reports however suggest that AFD is underdiagnosed.

**Methods.** We screened a kidney transplant population using a two-tier approach. The first tier was the determination of alpha-galactosidase A ( $\alpha$ -Gal A) activity using a dried blood spot on filter paper (DBFP); in the second tier, patients with the lowest alpha-galactosidase levels were further subjected to mutation analysis of the *GLA* gene.

**Results.** From the database of 2328 patients, 1233 subjects met the inclusion criteria. Finally, after informed consent, 673 patients were screened (54.5% – 395 women and 278 men). DBFP analysis resulted in a mean  $\alpha$ -Gal A of  $2.63 \pm 2.48 \mu\text{mol/L/h}$  (2.5 and 97.5 percentile were 0.0001 and  $5.07 \mu\text{mol/L/h}$ , respectively). Eleven patients were subjected to further genetic analysis. In a male patient a pathogenic missense mutation p.Ala143Thr (c.427A>G) was identified.

**Conclusions.** Our results show that the proposed approach can detect AFD patients in a until now seldomly screened high-risk group: kidney transplant patients. We conclude that screening for AFD in high-risk populations is a cost-effective, technically feasible and clinically valuable objective.

## Introduction

**A**nderson-Fabry disease (AFD) originates from a deficiency in alpha-galactosidase A ( $\alpha$ -Gal A), a lysosomal enzyme. This leads to the accumulation of glycosphingolipids (compounds with a biological role in membrane structure, modulation of membrane protein function and cell-cell recognition) intracellularly in the lysosomes [1,2]. The disease is X-linked and various incidence rates of the classical phenotype have been reported ranging from 1/40 000 to 1/117 000 live births [3,4].

Following the glycosphingolipid accumulation in various cell types, multi-organ involvement ensues and vital organs are affected: the kidneys, brain, heart. Dysfunction of these systems leads to considerable morbidity and increased mortality [4]. This clinical evolution is a continuum with a predominance in childhood of neuropathic pain and heat intolerance [5] to organ dysfunction in adolescence or adult age. It should however be pointed out that even children can present with classical signs of AFD. Due to its mode of inheritance, affected males develop clinical symptoms [4]; as a result of skewed lyonization, female carriers can develop the entire spectrum ranging from asymptomatic carriers to classical AFD [6–8].

AFD is however an underdiagnosed entity, as was demonstrated by screening studies performed in high-risk populations, such as patients on dialysis [9–13], patients with hypertrophic cardiomyopathy [14–17] and patients with cerebrovascular accidents at younger age [18,19]. Moreover, Spada et al. undertook a newborn screening by assaying the  $\alpha$ -Gal A activity in blood spots from 37 104 consecutive Italian male neonates. Identification of 12 neonates with a low  $\alpha$ -Gal A and corresponding mutations in the gene encoding  $\alpha$ -Gal A and subsequent family screening led to an incidence of 1 in 4600 in this population, with a predominance of later onset disease over the classical presentation [20]. Hence, care should be taken in interpreting previously reported incidence rates (often referring to the classical presentation of AFD).

In recent years a safe and efficacious treatment for AFD (enzyme replacement therapy; ERT) became available [21,22]. As a consequence, implementation of screening programmes in high-risk populations now seems a clinically relevant objective. Identifying index cases is not only of vital importance to these patients, but also to their family members, offering them the opportunity to be treated by ERT in an earlier disease stage. Following the successful screening by our group in haemodialysis patients [13], we extended our study to a risk group for Fabry disease for which data are scarce [30]: kidney transplant patients. We set up a community-wide screening programme in kidney transplant patients, based on a two-tier approach [23]: initial screening for  $\alpha$ -Gal A deficiency using the dried blood spot on filter paper (DBFP) technique [13,24], followed by standard genetic *GLA* gene mutation analysis of the high-risk persons identified in the first part of the study [2].



## **Materials and methods**

### *Patient selection*

In Flanders (the Dutch-speaking part of Belgium), the inventory of dialysis and transplant patients is well structured. The NBVN (Nederlandstalige Belgische Vereniging voor Nefrologie; a nephrology society grouping all 27 Flemish nephrology centres) issues a regularly updated database containing renal diagnosis, as well as the strength of evidence for this diagnosis. By the time of the start of this AFD screening study, 2328 patients were in the followup in one of the 27 Flemish nephrology centres after a successful transplantation ([www.nbvn.be](http://www.nbvn.be)). Those patients without biopsy-proven renal diagnosis or without clear reason for renal failure in their history prior to transplantation (e.g. autosomal dominant polycystic kidney disease, bilateral nephrectomy for kidney tumours) were enrolled. Given the prevalence of diabetes among patients with endstage renal disease, the latter were included in the screening provided they further complied with the inclusion criteria. Both genders older than 18 years were considered, without an upper-age limit. No known Fabry patients were enrolled.

### *Determination of $\alpha$ -Gal A activity using the technique of dried blood spot sampled on filter paper*

The screening test was based on a technique as described by Chamoles et al. [24]. In brief, a 3.2-mm disc was punched and incubated at pH 4.4 and at 37°C with 4-methyl umbelliferyl- $\alpha$ -galactopyranoside as substrate and N-acetyl-D-galactosamine as inhibitor for  $\alpha$ -galactosidase B. Enzymatic activities measured on a Thermo life science fluorometer (Thermo Electron Corporation, Waltham, MA, USA) were expressed as micromoles of substrate hydrolyzed per litre of blood per hour. This technique was previously validated in our laboratory as reported elsewhere [13]. Each DBFP viability was verified by measurement of beta-galactosidase; if beta-galactosidase activity was decreased in the DBFP test, the sample was rejected.

### *Determination of $\alpha$ -Gal A in white blood cells*

Where appropriate  $\alpha$ -Gal A levels in white blood cells were determined using the technique previously described by Desnick et al. [2].

### *Cut-off value for DNA mutation analysis*

The lower cut-off limit for  $\alpha$ -Gal A in our laboratory was set at 0.64  $\mu\text{mol/L/h}$ . All samples with activity levels below this threshold were re-examined and sample viability was verified using beta-galactosidase. If this rendered a too low value (normal lower cut-off limit for beta-galactosidase in our laboratory is 9.1  $\mu\text{mol/L/h}$ ), the sample was rejected. All samples with a low  $\alpha$ -galactosidase and a normal beta-galactosidase were subjected to DNA-mutation analysis.

### *DNA mutation analysis*

Genomic DNA was extracted from EDTA blood of the patients by standard protocols (Puregene DNA purification kit, Qiagen, Dusseldorf, Germany) according to the manufacturer's instructions. Mutation analysis was performed by PCR amplification followed by direct sequencing of the seven exons and flanking intronic sequences of *GLA* (Genbank: X14448.1-genomic). Primers used were modified from Eng et al. [25].

To exclude the presence of single- and multi-exon deletions in female patients, ML-PA analysis (multiplex ligation-dependent probe amplification) (MRC Holland, P159) was performed. Our mutation detection strategy allows us to obtain a mutation detection frequency in male and female patients of 100%.

### *Informed consent and Ethics*

The study protocol was approved by the Ethics committee of the Ghent University Hospital and all patients gave written or oral witnessed consent prior to participation. The study protocol is in accordance with the Declaration of Helsinki.

## **Results**

### *Patient selection*

Twenty nephrology units (74% of the total) participated in the screening study. From the database of 2328 patients, 1233 subjects met the inclusion criteria. Finally 673 patients gave informed consent and were screened (54.5% – 395 women and 278 men).

### *$\alpha$ -Gal A levels in the screening population (blood spot technique)*

DBFP analysis of the 673 transplant patients resulted in a mean  $\alpha$ -Gal A of  $2.63 \pm 2.48$   $\mu\text{mol/L/h}$  (2.5 and 97.5 percentile were 0.0001 and 5.07  $\mu\text{mol/L/h}$ , respectively).

### *DNA mutation analysis*

Based on the above-mentioned criteria, 11 patients with low  $\alpha$ -Gal A (2 men and 9 women) were subjected to further genetic analysis. In one male patient, the p.Ala143Thr (c.427A>G) missense mutation was identified.

### *Clinical correlation and family screening*

This 67-year-old male index patient started chronic haemodialysis therapy at the age of 33 because of stage 5 chronic kidney disease (CKD) without known renal diagnosis (no histological diagnosis). Prolonged dialysis therapy was complicated by secondary ( $\beta$ 2-microglobulin) amyloidosis manifested by bilateral carpal tunnel syndrome. At the age of 42 the patient suffered an ischaemic stroke; clinical recovery was incomplete with a residual mild left-sided hemiparesis. Fourteen years after dialysis initiation, he was transplanted with a renal allograft from a deceased donor. At present, 20 years later, the patient has remained

rejection free; renal allograft function is stable with a plasma creatinine concentration of 1.34 mg/dL and a calculated glomerular filtration rate of 45 mL/min. Proteinuria is absent while the urinary sediment is normal. Maintenance immunosuppressive therapy still consists of cyclosporin microemulsion (Neoral<sup>TM</sup>, Novartis, Basel, Switzerland), azathioprine (Imuran<sup>TM</sup>, GlaxoSmithKline, Genval, Belgium) and corticosteroids (Medrol<sup>TM</sup>, Upjohn, Diegem, Belgium). Thirteen years posttransplantation, at 60 years of age, a bilateral nephrectomy of the native kidneys was performed because of multifocal mixed-type renal cell carcinoma (RCC) comprising partly a papillary (chromophilic) type and an eosinophilic variant of the clear cell type (staging T1aN0M0). This was recently reported by Cassiman et al. [26]. Further posttransplant complications included arterial hypertension, hypercholesterolaemia, osteoporosis, bilateral cataracts and inguinal hernia with surgical repair. In 2005, the patient was treated for a paroxysmal supraventricular tachycardia with a beta-blocker (sotalol) but the latter had to be promptly stopped because of severe bradycardia and bifascicular conduction block. In 2006, a left-sided rolandic meningioma was diagnosed because of transient headaches; a conservative strategy was advised, postponing neurosurgical intervention in case of signs of motoric dysfunction or radiological progression. In retrospect, symptoms and signs that could have suggested AFD were absent in this patient: there was no history of neuropathic limb pain, no typical skin lesions (telangiectasias, angiokeratomas) nor corneal alterations (cornea verticillata). The development of stage 5 CKD in the third life decade concurs with AFD-related kidney disease but histological examination of the non-malignant renal tissue obtained after bilateral nephrectomy showed chronic glomerulonephritis, hyalinization and severe arteriosclerosis, but no lesions typical for Fabry disease. Of course, these non-specific histological lesions found almost 30 years after the development of ESRD do not exclude the earlier presence of specific AFD-related changes. Cardiac involvement might have been suspected based on the echocardiographic findings revealing hypertrophy of the interventricular septum with normal systolic and diastolic left ventricular function. In this regard however, other possibly contributing factors to the septal hypertrophy not related to AFD should be taken into consideration, e.g. volume overload during dialysis, episodes of arterial hypertension. In addition, a typical thickened hyper-echogenic layer [27], representing intracellular (sub)endocardial glycosphingolipid deposition, could not be clearly identified. The bifascicular block induced by a low dose of beta-blocker was only in retrospect suggestive of AFD-related cardiac conductive abnormalities. While the occurrence of ischaemic stroke at a young age is a common sign of neurological involvement in AFD, no typical or suggestive MR signs, like T1-weighted hyperintensity in the pulvinar (thalamus) [28], could be identified on repetitive brain imaging.

An extensive analysis of the family history was not helpful in establishing the presence of clinical AFD. The patient's mother died at the age of 91 years while the father died at age 63 years. Neither parent was known to have neurological, cardiac or renal disease. The patient's siblings (one brother of age 62 years and one sister of age 68 years) have no medical problems suggestive of AFD. However, the p.Ala143Thr (c.427A>G) missense mutation was detected in the sister (asymptomatic carrier) while the brother was confirmed to be non-

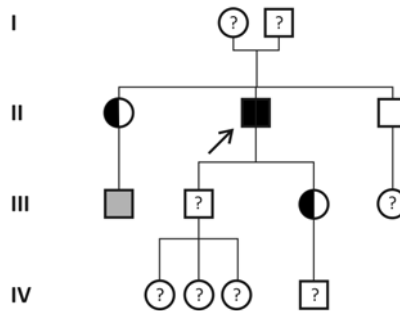

**Figure 2.4.** Pedigree of the index patient (arrow); black = mutation present; white = no mutation present; question mark = no genetic testing performed as yet; grey = low alpha-galactosidase A level, genetic testing pending – AFD very likely.

carrier (Figure 2.4). The son of the former has a clearly reduced  $\alpha$ -Gal A activity [ $<0.05 \mu\text{mol/L/h}$  (0.64–3.82)]; genetic testing is pending. The patient has one son (age 42 years) with 3 grandchildren (females: twins of 9 years, 12 years) and one daughter (age 43 years) with one grandson (age 23 years). The 43-year-old daughter was confirmed to carry the p.Ala143Thr (c.427A>G) missense mutation. Her son (23 years) has not been tested yet. None of these family members has AFD-related signs or symptoms. Despite the delayed diagnosis, treatment with recombinant human  $\alpha$ -Gal A is planned for the index patient. The results of his genetic confirmation test being pending, the nephew (37 years) of our index patient has a 50% risk of inheriting the mutation of the respective mother.

## Discussion

AFD is a rare genetic disorder [3,4], initially characterized by discrete and often non-specific signs and symptoms [5], with a natural evolution and progression often leading to vital organ failure. Although the clinical awareness for this disease has increased significantly in the last few years, systematic detection of carriers remains worthwhile. Screening entire populations (e.g. neonatal screening [20,23]) may be a valuable option to detect the disease in an early phase. A remarkable observation in this regard was made by Spada et al. [20] showing that the incidence of *GLA* mutations in male Italian neonates was considerably higher than that previously reported. The yield of population-wide screening programmes, however, is hampered by a considerable amount of false positives [23]. An additional drawback is that enzyme-based diagnosis of the disease is the gold standard in men, but using this technique only 2/3 of the female carriers are detected [29]. In women, these limitations should be appraised and taken into consideration.

Narrowing the screening programme to high-risk patient groups has already proven efficacious, as was demonstrated previously for cryptogenic stroke and for patients with hy-

peritrophic cardiomyopathy [14–19]. In haemodialysis patients a considerable number of successful screening studies have been reported in the literature, mainly in male patients and using different diagnostic techniques (blood spot, white blood cell enzyme detection, genetic analysis [9–13]). Our group recently reported a nation-wide screening study in a predominantly female dialysis patient group [13], and proved that, even taking into consideration the lower detection limit for AFD of enzymatic tests in female patients, blood spot-based screening can be useful.

As for a considerable number of patients, haemodialysis or peritoneal dialysis is merely a transition to kidney transplantation, it can be hypothesized that in the renal transplant recipient group, some misdiagnosed or undiagnosed AFD patients may be found. It was the goal of this study to document and test this hypothesis.

We used a two-tier approach with a blood spot-based (and cheap) detection of ‘risk-patients’ followed by a more expensive and time-consuming genetic analysis. We chose to screen women also by alpha-galactosidase activity, keeping in mind the limitations as reported by Linthorst [29], showing that that only 2/3 of the female patients are detected by this approach. This enabled us however to screen more patients at lower cost.

In contrast to our previously reported dialysis screening programme, we did not impose an upper age limit in male patients, as recent reports point out that the spectrum of AFD presentations in male patients is much wider than that previously estimated. This decision is corroborated by the detection by this screening of a 67-year-old male transplanted Fabry patient.

Once the diagnosis established in the proband, screening for a genetic disease within a family can be very difficult as is illustrated by the family presented: the proband had a full clinical and genetic work-up, but his ‘hemizygous’ sister only had an enzymatic and genetic work-up (she refused further clinical and biochemical testing, because she was ‘well’ and, to her standards, ‘aged enough not to bother about that kind of things’); the hemizygous sister’s son had enzyme testing which was clearly abnormal, but he has refused further testing so far (‘I’m well’). The proband’s daughter is an obligatory ‘carrier’, which was confirmed genetically and enzymatically; she has no apparent cardiovascular, neurological or renal involvement. Her only son was only informed of the disease running in his family last week, due to relational problems in the family. Further family screening and detailed mapping of disease burden in possibly affected members will of course be pursued ceaselessly.

It is of interest to note that in 10 out of the 11 genetically tested patients with low  $\alpha$ -Gal A, no mutation in the *GLA* gene was found. Mutation analysis was performed by two complementary techniques: direct sequencing of the seven *GLA* exons and exon-flanking boundaries in male and female individuals and MLPA, exclusively in female patients. In affected males, the sensitivity of direct sequencing is estimated to approximate 100%. In heterozygous females, the sensitivity of direct sequencing is most certainly lower as whole gene and full exonic deletions will be missed. These genetic aberrations will, however, be reliably detected by the MLPA analyses we included for female patients.

Therefore, we are confident that the adopted strategy is sufficiently sensitive. Of note, di-

rect sequencing (with or without MLPA) was the method of choice in most recent screening studies for Fabry's disease. Evidently, it should be appreciated that certain, albeit extremely rare, pathogenic genetic alterations (such as mutations in or methylation of the *GLA* promoter) will not be detected by the adopted strategy. As a consequence, the concern of missing pathogenic mutations remains an important issue in selected cases. In a suggestive clinical setting, clinicians are therefore encouraged to demonstrate globotriaosylceramide deposition by alternative and complementary analyses such as electronmicroscopic studies of skin or renal biopsy specimens. This however is beyond the scope of this screening project and merits further investigation.

The total cost of this screening is small, as compared to the gains. As our blood spot technique costs 6.25 euro per analysis, the first tier of our test costed 4206.25 euro. The second tier (genetic analysis) costed  $11 \times 337.5$  euro = 3712 euro. Hence the total cost of the screening programme amounted to ~8000 euro. Had we omitted the first tier in female patients to apply the second tier directly, those costs would have been considerably higher [ $(278 \times 6.25$  euro) +  $(2 \times 337.5$  euro) +  $(395 \times 337.5$  euro) = 135 725 euro], with only a limited increase in the power of our screening. Andrade et al. recently discussed the possible limitations of the blood spot assay [30]. These should of course be kept in mind, but need further confirmation as these statements were based on the screening of a very heterogenous patient population (chronic renal failure, patients on renal replacement therapy, transplant patients) and no *GLA* mutation carriers were detected. The validation of our blood spot test for alpha-galactosidase activity was reported previously [13] and showed reproducible results.

Our results show that this two-tier method can detect Fabry disease in renal transplant recipients, even in atypical clinical settings and in patients not previously considered high-risk (renal transplant recipients). As we mentioned previously [13], the detection of a *GLA* mutation is not only of vital importance to the patient under study, but also to putatively affected family members, who can be treated in an earlier phase of the disease, before vital organ damage is installed. Indeed, in the reported family, a hitherto asymptomatic grandson was identified. ERT in this patient may lead to prevention of organ damage, stabilization of incurred damage or even improvement. In contrast, the obligatory heterozygous carrier state of the patient's mother who died at 91 years also suggests that the possible ERT of these carriers should be carefully balanced with the life expectancy and influence of the expensive treatment on changing this life expectancy.

## References

1. Brady R, Gal A, Bradley R et al. Enzymatic defect in Fabry's disease. Ceramidetrihexosidase deficiency. *N Engl J Med* 1967; 276: 1163–1167
2. Desnick R, KY Allen K, Desnick S et al. Fabry's disease: enzymatic diagnosis of hemizygotes and heterozygotes. Alpha-galactosidase activities in plasma, serum, urine, and leukocytes. *J Lab Clin Med* 1973; 81: 157–171

3. Meikle P, Hopwood J, Clague A et al. Prevalence of lysosomal storage disorders. *JAMA* 1999; 281: 249–254
4. Branton M, Schiffmann R, Sabnis S et al. Natural history of Fabry renal disease: influence of alpha-galactosidase activity and genetic mutations on clinical course. *Medicine (Baltimore)* 2002; 81: 122–138
5. Desnick R, Brady R. Fabry disease in childhood. *J Pediatr* 2004; 144: S20–S26
6. Deegan P, Baehner A, Barba Romero M et al. (European FOS Investigators). Natural history of Fabry disease in females in the Fabry outcome survey. *J Med Genet* 2006; 43: 347–352
7. Whybra C, Kampmann C, Willers I et al. Anderson-Fabry disease: clinical manifestations of disease in female heterozygotes. *J Inher Metab Dis* 2001; 24: 715–724
8. Kampmann C, Baehner F, Whybra C et al. Cardiac manifestations of Anderson-Fabry disease in heterozygous females. *J Am Coll Cardiol* 2002; 40: 1668–1674
9. Linthorst G, Hollak C, Korevaar J et al. Alpha-galactosidase a deficiency in Dutch patients on dialysis: a critical appraisal of screening for Fabry disease. *Nephrol Dial Transplant* 2003; 18: 1581–1584
10. Nakao S, Kodama C, Takenaka T et al. Fabry disease: detection of undiagnosed hemodialysis patients and identification of a 'renal variant' phenotype. *Kidney Int* 2003; 64: 801–807
11. Kotanko P, Kramar R, Devrnja D et al. Results of a nationwide screening for Anderson-Fabry disease among dialysis patients. *J Am Soc Nephrol* 2004; 15: 1323–1329
12. Merta M, Reiterova J, Ledvinova J et al. A nationwide blood spot screening study for Fabry disease in the Czech Republic haemodialysis patient population. *Nephrol Dial Transplant* 2007; 22: 179–186
13. Terryn W, Poppe B, Wuyts B et al. Two-tier approach for the detection of alpha-galactosidase A deficiency in a predominantly female haemodialysis population. *Nephrol Dial Transplant* 2008; 23: 294–300
14. Nakao S, Takenaka T, Maeda M et al. An atypical variant of Fabry's disease in men with left ventricular hypertrophy. *N Engl J Med* 1995; 333: 288–293
15. Ommen S, Nishimura R, Edwards W. Fabry disease: a mimic for obstructive hypertrophic cardiomyopathy. *Heart* 2003; 89: 819–820
16. Sachdev B, Takenaka T, Teraguchi H et al. Prevalence of Anderson-Fabry disease in male patients with late onset hypertrophic cardiomyopathy. *Circulation* 2002; 105: 1407–1411
17. Chimenti C, Pieroni M, Morgante E et al. Prevalence of Fabry disease in female patients with late-onset hypertrophic cardiomyopathy. *Circulation* 2004; 110: 1047–1053
18. Brouns R, Sheorajpanday R, Braxel E et al. A retrospective Belgian study on the prevalence of Fabry disease in young patients with cryptogenic stroke. *Clin Neurol Neurosurg* 2007; 109: 479–484
19. Rolfs A, Bottcher T, Zschiesche M et al. Prevalence of Fabry disease in patients with cryptogenic stroke: a prospective study. *Lancet* 2005 366: 1794–1796. Erratum in: *Lancet* 2006; 368: 2210.
20. Spada M, Pagliardini S, Yasuda M et al. High incidence of later-onset Fabry disease revealed by newborn screening. *Am J Hum Genet* 2006; 79: 31–40
21. Eng C, Guffon N, Wilcox W et al. (the International Collaborative Fabry Disease Study Group). Safety and efficacy of recombinant human  $\alpha$ -galactosidase a replacement therapy in Fabry's disease. *N Engl J Med* 2001; 345: 9–16
22. Schiffmann R, Kopp J, Austin H et al. Enzyme replacement therapy in Fabry disease: a randomized controlled trial. *JAMA* 2001; 285: 2743–2749

23. Meikle P, Ranieri E, Simonsen H et al. Newborn screening for lysosomal storage disorders: clinical evaluation of a two-tier strategy. *Pediatrics* 2004; 114: 909–916
24. Chamoles N, Blanco M, Gaggioli D. Fabry disease: enzymatic diagnosis in dried blood spots on filter paper. *Clin Chim Acta* 2001; 308: 195–196
25. Eng C, Resnick-Silverman L, Niehaus Det al. Nature and frequency of mutations in the alpha-galactosidase a gene that cause Fabry disease. *Am J Hum Genet* 1993; 53: 1186–1197
26. Cassiman D, Claes D, Lerut E et al. Bilateral renal cell carcinoma development in long-term Fabry disease. *J Inherit Metab Dis* 2007; 30: 830–831
27. Pieroni M, Chimenti D, De Cobelli M et al. Fabry's disease cardiomyopathy : echocardiographic detection of endomyocardial glycosphingolipid compartmentalization. *J Am Coll Cardiol* 2006; 47: 1663–1671
28. Takanashi J, Barkovich AJ, Dillon WP et al. T1 hyperintensity in the pulvinar: key imaging feature for diagnosis of Fabry disease. *Am J Neuroradiol* 2003; 24: 916–921
29. Linthorst G, Vedder A, Aerts J et al. Screening for Fabry disease using whole blood spots fails to identify one-third of female carriers. *Clin Chim Acta* 2005; 353: 201–203
30. Andrade J, Waters P, Singh R et al. Screening for Fabry disease in patients with chronic kidney disease: limitations of plasma  $\alpha$ -galactosidase assay as a screening test. *Clin J Am Soc Nephrol* 2008; 3: 139–145.



## Paper Three

### Prevalence of Fabry disease in a predominantly hypertensive population with left ventricular hypertrophy

*Terryn W, Deschoenmakere G, De Keyser J, Meersseman W, Van Biesen W, Wuyts B, Hemelsoet D, Pascale H, De Backer J, De Paepe A, Poppe B, Vanholder R.  
Int J Cardiol. 2012 Jul 15. Epub.*

#### **Abstract**

**Background:** Patients with Fabry disease (FD) develop progressive left ventricular hypertrophy (LVH). In screening studies in patients with LVH, the prevalence of FD ranges from 0 to 12%. This variability is attributable to different factors like diverging inclusion and exclusion criteria, the evaluation of selected populations and suboptimal screening methods. In this study, we aimed to determine the prevalence of FD in an unselected population of everyday clinical practice presenting LVH, defined as a maximal end-diastolic septal or posterior wall thickness  $\geq 13$  mm, without exclusion of patients with arterial hypertension or valvular pathology, and using optimal screening methods.

**Methods:** In adult males, a two-tier approach was used;  $\alpha$ -Galactosidase A ( $\alpha$ -Gal A) activity was measured using a dried bloodspot test (DBS) and diagnosis was confirmed by mutation analysis of the *GLA* gene. In females, mutation analysis was the primary screening tool.

**Results:** 362 men and 178 women were screened. Six patients were diagnosed with a genetic sequence alteration of the *GLA* gene. One man had a novel mutation, *GLA* p.Ala5Glu (c.44C>A), presenting as classical FD. Another man and three women had the previously described *GLA* p.Ala143Thr (c.427G>A) mutation, which generally presents as an attenuated phenotype. One woman had a novel sequence alteration c.639+6A>C, which appeared to be a polymorphism. All true Fabry patients had arterial hypertension (AHT), and one had hypertrophic obstructive cardiomyopathy (HOCM).

**Conclusions:** In a group of unselected patients with LVH, we found a prevalence of Fabry disease of 0.9%. AHT or type of hypertrophy should not be an exclusion criterion for screening for FD.

## Introduction

**F**abry disease (FD) is an X-linked lysosomal storage disease caused by abnormalities in the *GLA* gene leading to a partial or absolute deficiency of the lysosomal enzyme  $\alpha$ -Galactosidase A ( $\alpha$ -Gal A). This results in the accumulation of glycosphingolipids, especially globotriaosylceramide (Gb-3) in the lysosomes of various cells, which leads to various end-organ manifestations including left ventricular concentric remodeling and subsequent hypertrophy. Though rare, asymmetric hypertrophy has also been described [1,2]. Cardiovascular involvement contributes substantially to disease-related morbidity and mortality in FD [3]. Enzyme replacement therapy has been shown to reduce left ventricular mass and wall thickness [4–6]. As a consequence, early diagnosis and treatment of these patients has the potential to modify the natural course of the disease and reduce morbidity and mortality and offers the possibility to diagnose family members in an earlier stage of the disease.

Over the past decade, a number of studies have suggested that FD can present in patients with an echocardiographic phenotype of hypertrophic cardiomyopathy (HCM), de-

**Table 2.1.** Summary of previous studies of FD in LVH.

Authors <sup>7-14</sup>	Population	LVH selection criteria	Screening method	Prevalence	Limitations
Nakao 1995	230 males	LVH $\geq$ 13 mm Otherwise unselected	$\alpha$ -Gal A	3%	Only males Single centre; tertiary referral centre In 5/7 cases, no mutation was found in the coding regions of the <i>GLA</i> gene
Sachdev 2002	79 males $\geq$ 40 y 74 males <40 y	HCM $\geq$ 13 mm	$\alpha$ -Gal A	6.3 % 1.4 %	Only males Exclusion of hypertension and valvular disease Single centre; tertiary referral centre
Ommen 2003	100 (44 males)	Symptomatic HOCM	Myomectomy; electron microscopy	0	Asymmetric hypertrophy is rare in FD Exclusion of hypertension and valvular disease Retrospective study Single centre; tertiary referral centre
Chimenti 2004	96 (62 males)	HCM $\geq$ 13 mm	Myocardial biopsy	6.2% in female 12%	Exclusion of hypertension and valvular disease Biopsy study; selection bias ? (suspicion of infiltrative disease) Single centre; tertiary referral centre
Arad 2005	75 (45 males)	HCM $\geq$ 13 mm	genetic	0	Exclusion of hypertension and valvular disease Single centre; tertiary referral centre Inclusion of very young (> 12y)
Monserrat 2007	508 (328 males)	HCM	$\alpha$ -Gal A	1%	Exclusion of hypertension and valvular disease Use of $\alpha$ -Gal A in females
Havndrup 2010	90 (56 males)	HCM	genetic	3%	Single centre; tertiary referral centre Low number of patients
Hagège 2011	392 (278 males)	HCM $\geq$ 15 mm	$\alpha$ -Gal A	1% (1.5% in men >18y and 1.8% in men >40y)	Exclusion of hypertension and valvular disease Use of $\alpha$ -Gal A in females High cut-off for LVH (15 mm instead of 13 mm)
Elliot 2011	1386 (885 males)	HCM $\geq$ 15 mm	genetic	0.5%	Exclusion of hypertension and valvular disease Age limitation (35+ for men and 40+ for female) High cut-off for LVH (15 mm instead of 13 mm)

LVH = Left Ventricular Hypertrophy; HCM = Hypertrophic Cardiomyopathy; HOCM = Hypertrophic Obstructive Cardiomyopathy;  
 $\alpha$ -Gal A =  $\alpha$ -Galactosidase A activity measurement

fined by the presence of LVH in the absence of abnormal loading conditions such as arterial hypertension (AHT) or aortic valve abnormalities (Table 2.1 [1,7–14]). It was supposed that these abnormal loading conditions generally explained LVH and therefore these patients were excluded in screening studies for FD. The only exception is an older study [7]. Fifty-three percent of the patients had AHT and 5% had aortic valve dysfunction. Nevertheless, an unexpectedly high number of patients (3%) were diagnosed with a low  $\alpha$ -Gal A activity and/or Gb-3 deposits in themyocardial cells. A possible explanation for this high prevalence is selection bias as this study was undertaken in a highly selected population of only males attending a single tertiary reference center.

As a considerable part of the Fabry population has AHT [15,16] and most of the patients with LVH followed by cardiologists in everyday practice have hypertension or valvular disease, we think that screening for FD in patients with LVH should include patients with hypertension and aortic valve disease. This would allow the determination of the true prevalence of FD in patients with LVH and would allow answering the question whether this prevalence is high enough towarrant overall screening in such populations.

Most of the published prevalence studies focusing on FD in LVH have methodological shortcomings including selection bias (predominantly in male patients or in single, highly specialized referral centers) and the use of inappropriate screening methods, such as  $\alpha$ -Gal A activity measurement in women [17].

The purpose of this study is to determine the prevalence of FD in patients with LVH attending everyday hospital practices for cardiological examination, using optimal screening tools.

## **Materials and methods**

### *Primary hypothesis*

FD is likely to account for an unknown but considerable number of LVH even in unselected patients.

### *Study centers*

Ten cardiologists in eight secondary care hospitals and two tertiary care hospitals (Appendix 1), in Flanders, Belgium, participated in the study, guaranteeing the recruitment of an unselected patient population.

### *Study population*

All patients (male and female) of 18 years or older who underwent an echocardiography were eligible to be included in the screening program. Patients were eligible for inclusion if on 2D echocardiography the maximal end-diastolic septal or posterior wall thickness was  $\geq 13$  mm. Wall thickness was measured by 2D-guided M-mode at papillary muscle level in parasternal long axis or parasternal short axis view. All measurements were made at end-

diastole (at onset of the R wave).

AHT, valvular disease or other possible causes for LVH were not an exclusion criterion. AHT was defined as  $\geq 140$  mm Hg systolic blood pressure or being on antihypertensive medication.

### *Ethical issues*

The design of the study was approved by the ethics committee of the Ghent University Hospital (EC nr 2009/35) and by the local ethics committees in all participating centers and conforms to the ethical guidelines of the 1975 Declaration of Helsinki. Since it was designed as a purely observational study, patients received therapy and diagnostic procedures according to local practice. Written informed consent was obtained from all patients.

The authors of this manuscript have certified that they comply with the Principles of Ethical Publishing in the International Journal of Cardiology [18].

### *Echocardiographic measurements*

Echocardiographic measurements were performed according to the European Guidelines of Chamber Quantification [19].

### *Determination of $\alpha$ -Gal A using the technique of dried blood spot sampled in filter paper*

The screening test in males was based on dried blood spots (DBS) sampled on filter paper as described by Chamoles et al [20]. In brief, a standardized disk was punched out of a filter paper and consequently incubated at physiologic pH (7.365) and at 37 °C with 4-methylumbelliferyl- $\alpha$ -galactopyranoside as substrate. Enzyme activity renders the enzyme product 4-methylumbelliferone (4-MU), a fluorescent molecule. The fluorescence (excitation, 365 nm; emission, 450 nm) was measured on a Thermo Life Science fluorometer (Thermo Electron Corporation, Waltham, MA, USA). The fluorescence readings were corrected for blanks, and the results were compared with the fluorescence from a 4-methylumbelliferone calibrator. Enzymatic activities were expressed as micromoles of substrate hydrolyzed per liter of blood per hour. To validate this technique in our laboratory setting, we performed an analysis of 50 patient samples (non-nephrology, non-ICU, non-hematology, non-pediatric). Results were compared with literature data. Each DBS test for  $\alpha$ -Gal A was validated by measurement of  $\beta$ -Galactosidase (as a technical comparator for enzymatic analysis). If no  $\beta$ -Galactosidase activity was detectable in the DBS test, the sample was rejected.

### *2.7. Genetic screening*

Mutation analysis was performed in all female patients and in men with an absent or low ( $0.64 \mu\text{mol/L/h}$ )  $\alpha$ -Gal A activity measured with DBS test. Genomic DNA was extracted from EDTA blood by standard protocols. Mutation analysis was performed by PCR amplification followed by direct sequencing of the 7 exons and flanking intronic sequences of *GLA* gene according to Ploos van Amstel et al. [21]. The presence of large gene rearrangements was evaluated by QF PCR (custom made kit by Prestagen). Sequence variations found in the

*GLA* gene were compared with published data on known pathogenic mutations and non-disease-causing polymorphisms.

## Results

### Screening results

540 patients (362 males and 178 females) were screened (Table 2.2). 488 patients (90.4%) had a systolic blood pressure of  $\geq 140$  mm Hg or were on antihypertensive medication. The mean (SD) diameter of the left ventricular septum or posterior wall thickness was 15.87 (3.22) mm, with a range of 13.0–39.1 mm. The population had a mean age of 68.8 y (range 19–93 years).

Two male patients had a confirmed low  $\alpha$ -Gal A activity measured with DBS, and both had a missense mutation, yielding a mutation prevalence in men of 0.55%. The *GLA* p.Ala5Glu (c.44C>A) was a novel mutation, while the *GLA* p.Ala143Thr (c.427G>A) mutation has previously been described as associated with an attenuated phenotype [22]. Four females were found to carry a *GLA* missense sequence alteration. The c.639+6A>C sequence alteration in 1 patient was novel, whereas the other females had the *GLA* p.Ala143Thr (c.427G>A) mutation. All five Fabry patients detected in this screening study were unrelated and lived at geographic distant locations through Flanders.

**Table 2.2.** Characteristics of the study population.

	Overall population	Male	Female
Number (%) <sup>*</sup>	540 (100)	362 (67)	178 (33)
Mean age (y) (SD, range)	68.8 (14.25, 19-93)	66.8 (14.48, 19-93)	73.0 (12.79, 34-93)
N (%) with <i>GLA</i> mutation	5 (0.94)	2 (0.55)	3 (1.68)
Mean septum thickness (mm)(SD, range) †	15.87 (3.22, 13-39.1)	15.94 (3.26, 13-38)	15.72 (3.11, 13-39.1)
N (%) with RR syst 140 mmHg or more	287 (53.1)	185 (51.1)	102 (57.3)
N (%) taking antihypertensive medication	440 (81.5)	284 (78.5)	156 (87.6)
N (%) syst RR 140 mmHg or more or taking antihypertensive medication	488 (90.4)	322 (89.0)	166 (93.3)
N (%) with a family member in the first or second degree with kidney disease, precocious CVA or sudden death	93 (17.2)	64 (17.7)	29 (16.3)

\* one CFR was missing, † calculated in 533 patients as 7 data were missing

### Patient description (Table 2.3)

*GLA* p.Ala143Thr (c.427G>A). Patient 1 is a 48-year-old man with AHT, concentric LVH with a septum of 14 mm and a normal systolic left ventricular function, but a slow relaxation. His  $\alpha$ -Gal A activity is undetectable. In his medical history, we note type 2 diabetes since 13 years, peripheral polyneuropathy, erectile dysfunction and a diabetic foot at the age of 46 years. He has renal insufficiency with a creatinine clearance of 35 mL/min (measured with 24 h urine collection) and a proteinuria of 3 g/24 h. For a year, he has had diffuse headaches with anorexia and weight loss. On clinical neurological examination, there

**Table 2.3.** Patients with FD mutations.

Patient	1	2	3	4	5
Age/sex	M/48	F/78	F/70	F/83	M/38
Angiokeratoma	-	-	-	-	-
Acroparesthesia	-	-	-	-	+
Hypohidrosis	-	-	-	-	+
Hearing impairment	-	-	-	-	+
Arterial hypertension	+	+	+	+	+
Septal wall thickness (mm)	14	23	16	20	13
Asymmetric hypertrophy	-	-	-	+	-
$\alpha$ Gal A activity*	0	NA	0.25	0.48	0
GLA mutation	c.427G>A	c.427G>A	c.427G>A	c.427G>A	c.44C>A

NA: not available; \* normal values 0.64–3.82  $\mu$ mol/l/h

was no apparent deficit. Magnetic resonance imaging of the brain however showed multiple brain lesions: acute ischemic lesions and white matter lesions, which could be older ischemic lesions. Ophthalmologic examination shows a diabetic proliferative retinopathy, but no tortuous vessels or cornea verticillata. A kidney biopsy shows a Kimmelstiel–Wilson nephropathy with no signs of Gb-3 deposits. He has only one sister carrying the mutation, without signs of organ involvement at thorough clinical workup, including a kidney biopsy because of micro-albuminuria. The sister's children, in their twenties, were reluctant to participate in further investigation. The patient has four daughters between 10 and 20 years of age who are obligate carriers but who have no complaints. The oldest daughter has a low  $\alpha$ -Gal A activity (0.27  $\mu$ mol/L/h). His parents died at old age of unknown cause.

Patient 2 is a 78-year-old woman with AHT, symmetric cardiac hypertrophy and a maximal ventricular wall thickness of 23 mm with normal left ventricular ejection fraction. She has a serum creatinine of 1.36 mg/dL and an estimated glomerular filtration rate (MDRD) of 38 mL/min. Because of a monoclonal gammopathy, amyocardial biopsy is taken, which shows amyloid light chain amyloidosis and Gb-3 deposits. She died during her hospitalization because of decompensated diastolic heart failure. As the treating cardiologist did not consider the mutation significant, he did not inform the general practitioner and the family of this mutation.

Patient 3 is a 70-year-old woman who was successfully treated for AHT with a beta-blocker and an ACE inhibitor. She has symmetric LVH with a left ventricular wall thickness of 16 mm, which increased progressively despite control of hypertension. She has no cornea verticillata, no neurological signs or symptoms, a normal serum creatinine and no proteinuria. She has a family history of sudden death, with her father dying at the age of 52. One of her brothers suffers from atrial fibrillation, and another brother had a myocardial infarction and suffers from heart failure.

Patient 4 is an 83-year-old woman admitted to the hospital because of ischemic stroke. She has a history of AHT, ischemic stroke, HOCM and arrhythmia. She has a serum creatinine of 1.02 mg/dL and no proteinuria. She has asymmetric LVH with a maximal left ventricular wall thickness of 20 mm. Her  $\alpha$ -Gal A activity is 0.48  $\mu$ mol/L/h (normal range 0.64–3.82). Her

brother, two sisters and parents died at an advanced age of unknown cause.

3.3. *GLA p.Ala5Glu (c.44C>A)* ( Fig. 2.5, Table 2.4)

Patient 5 is a 46-year-old man with a history of AHT. LVH is suggested by electrocardiogram (ECG) and confirmed with echocardiography showing a left ventricular septum of 13 mm. He suffers from hearing loss and coronary artery disease for which he had several coronary stents. In his childhood, he suffered from anhydrosis and paresthesia. On clinical examination, he has no angiokeratoma. He has a serum creatinine of 1.40 mg/dL, an eGFR (MDRD) of 54 mL/min/1.73 m<sup>2</sup> [2] and no proteinuria (under treatment with an ACE inhibitor). A kidney biopsy was suggested, but as the patient had recently received several coronary stents, for which he took clopidogrel, it was considered not safe. In addition, this patient and his pedigree has a classical Fabry phenotype, this leaves no doubts about the diagnosis and no real need for a biopsy to complete the diagnosis. A-Gal A activity is undetectable. His pedigree shows several family members with classical Fabry symptoms. His mother died at the age of 64 as the consequence of stroke, and his aunt died at 45 with vascular disease

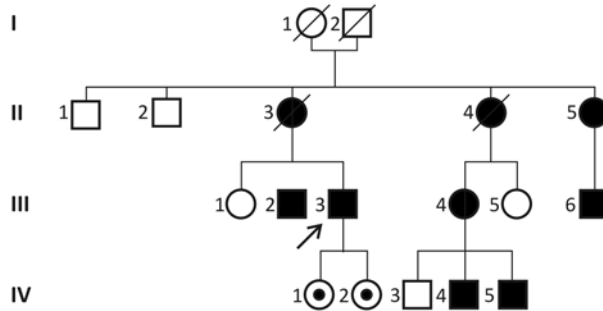

**Figure 2.5.** Family pedigree of the patient with *p.Ala5Glu (c.44C>A)*. Legend: circles are females and squares are males. Filled symbols are affected patients. Dashed symbols are deceased patients. The arrow indicates the index patient. Dotted means carriers without symptoms.

**Table 2.4.** Clinical manifestations of affected family members of the patient with *GLA p.Ala5Glu (c.44C>A)*.

	II3	II4	II5	III2	III3	III4	III6
Age, Sex	64,F	45,F		39,M	46,M	60,F	49,M
Angiokeratoma				+	-	-	-
Acroparesthesia				+		-	+
Hypohidrosis					+	-	+
Hearing impairment				+	+	-	-
Stroke	+		+		-	-	+
White matter lesions						+	+
Renal failure		+			+	-	+
Arterial Hypertension					+	-	+
LVH					+	-	+
αGAL A activity (μmol/l/h)					0	'low'	0

Blank spaces means the information is not available; “-” means the symptom is absent; ‘low’ means under the lower normal level (no further detail available)

and renal failure. His brother and cousin also have typical Fabry symptoms. His niece (60 years of age) carries the same mutation but is asymptomatic. He has two young daughters who are carriers but who have no signs or symptoms of FD.

The *GLA* p.Ala5Glu (c.44C>A) mutation has not been described in the literature, and appears to result in classical FD.

### 3.4. C.639+6A>C

A 75 year old female with AHT, coronary artery disease and LVH(basal septum 15 mm) has a sequence variation in an intronic location c.639+6A>C, which has not yet been described in literature and which was not encountered in our control population (healthy population) nor in the other patients sequenced in this study. She has two sons of 44 and 47 years of age, carriers of the same sequence variation, who have a normal  $\alpha$ -Gal A and no clinical signs or symptoms compatible with FD. It is concluded that this sequence variation is a low-prevalence polymorphism.

## Discussion

In an unselected albeit predominantly hypertensive, older population with LVH, we found 2 male and 3 female patients with mutations in the *GLA* gene yielding an overall prevalence of 0.93%. Four out of five patients, who are apparently unrelated and live at distant locations from each other, have the same *GLA* p.Ala143Thr (c.427G>A) mutation. In a recent newborn screening in Austria this mutation was found in 6 out of 9 Fabry patients [23], which is in accordance with the high prevalence we found in the present study. FD is a rare disease with a reported prevalence of 0.02 to 0.09 per 10,000 persons in the general population [24] but is probably under-ascertained because of its rarity and because presenting symptoms are frequently nonspecific and variable. Screening studies for FD in high risk populations (left ventricular hypertrophy, stroke, dialysis) [25] and in newborns [23,26,27] yield much higher frequencies but this is for a large part due to the detection of attenuated (later-onset) phenotypes. Many patients (males and females) with FD develop LVH. In a cross-sectional study of untreated FD patients, half of the men and one third of the women were classified as having LVH (defined as LVMi of  $\geq 51$  g/m<sup>2.7</sup> for males and  $\geq 48$  g/m<sup>2.7</sup> for females) [28]. In general, hypertension on its own is considered to be responsible for LVH. Hence, hypertensive patients are almost systematically excluded from screening studies for metabolic heart disease. Currently (April 2012), nine papers documented the prevalence of FD in patients with LVH, yielding frequencies from 0 to 12% (Table 2.1). Of the nine screening studies, eight screened only in hypertrophic cardiomyopathy (HCM), and hypertensive patients were explicitly excluded in seven. The only study that included hypertensive patients for screening for FD was performed in a uniquely male population in whom hypertension was present in 53% [7]. An unexpectedly high prevalence of 3% was found, although selection bias cannot be excluded as the study was restricted to one single tertiary referral center. Most likely, this explains why FD was almost 6 times more prevalent than in



males in our study group from an everyday in- and outpatient hospital population (0.55%).

The prevalence of FD has been underestimated mainly because of the high prevalence of later-onset phenotypes. At this age, Fabry patients with LVH may also have hypertension, considering the high prevalence of hypertension in the general population and the possibility of hypertension secondary to renal disease in these patients. For this reason, we decided to include hypertensive patients in our screening protocol. Indeed, all of our patients with a molecular diagnosis of Fabry disease were previously treated for hypertension. This proves that screening for FD in general cardiology practice, which has a very high prevalence of hypertension (90% in our patients) is not futile. Furthermore, it is important to screen for FD in hypertensive LVH patients because AHT and LVH are not rare in FD and are particularly associated with a higher cardiovascular morbidity [29].

Most previous studies have been performed in highly selected populations in tertiary treatment centers, and only two studies were multicentric similar to our evaluation while they also evaluated both genders [11,12]. However, in those studies, female cases could have been missed, as  $\alpha$ -Gal A activity measurement was used as a screening tool which can be falsely normal in up to 40% of women with FD [17]. For this reason, it is now accepted that in women, the primary screening tool should be mutation analysis [30], which was also the approach followed in our study.

Asymmetric septal hypertrophy indistinguishable from that seen in sarcomeric cardiomyopathies, accounts for 5% of FD patients with LVH [31]. Dynamic left ventricular outflow obstruction is rare, but does occur, as in our patient 4. As a consequence, it is conceivable that also asymmetric LVH should not be an exclusion criterion for screening for FD.

The patient with the novel *GLA* p.Ala5Glu (c.44C>A) mutation presented with a classical clinical picture of FD (including acroparesthesia, hearing impairment, anhydrosis, LVH and renal insufficiency). There was also a suggestive familial history for FD. In this case, a careful personal and family survey could have provided useful information for a correct diagnosis. More precisely, the patient was not specifically asked for the presence of anhydrosis and the predominant symptom was hearing loss, a feature whereby clinicians did not consider the possibility of FD. Thus, this classic case of FD was missed in everyday medical practice, which demonstrates that FD remains underdiagnosed, and is easily overlooked, and that diagnostic screening combined with pedigree analysis remains important for case detection.

## Clinical implications and conclusion

The present study demonstrates that, since FD is present in approximately 1% of unselected patients with LVH, this disease should be considered in the differential diagnosis of all patients with LVH, without exclusion of AHT, asymmetric hypertrophy, women or older patients. Screening remains an important tool for case finding as even classical FD may otherwise go undetected, while a correct diagnosis is important in view of recent advances in the treatment of FD which may offer stabilization and even reversal of cardiovascular manifestations and other symptoms [4,5].

Tree of the five patients were 70 years or older. We cannot exclude in these cases that

other causes, besides hypertension and FD, contributed to LVH (e.g. amyloidosis in case 2). Moreover, it needs to be determined whether in these older patients an expensive treatment such as enzyme replacement therapy is still worthwhile to consider. Probably, pedigree analysis is the only beneficial consequence of finding a mutation in these older patients.

Four out of five Fabry cases in this study had a mutation that is generally associated with later-onset Fabry disease (*GLA* p.Ala143Thr (c.427G>A) ).

The contribution of the mutation to the clinical picture (stroke, renal failure and even LVH) should be the subject of a thorough clinical workup in a center with expertise in FD.

### Limitations

Although biochemical screening is generally accepted to be very sensitive in screening in males and DBS is probably as accurate as the gold standard (determination of  $\alpha$ -Gal A activity in leukocytes) Andrade [32] showed that using plasma may fail to detect some male patients with FD. Our method using DBS test could be prone to the same bias. However, if this were the case, this would mean that the real prevalence of FD in males with LVH might even be higher than described here.

### References

1. Ommen SR, Nishimura RA, Edwards WD. Fabry disease: a mimic for obstructive hypertrophic cardiomyopathy? *Heart* 2003;89(8):929–30.
2. Wu JC, Ho CY, Skali H, et al. Cardiovascular manifestations of Fabry disease: relationships between left ventricular hypertrophy, disease severity, and  $\alpha$ -galactosidase A activity. *Eur Heart J* 2010;31(9):1088–97.
3. Linhart A, Kampmann C, Zamorano JL, et al. Cardiac manifestations of Anderson-Fabry disease: results from the international Fabry outcome survey. *Eur Heart J* 2007;28(10):1228–35.
4. Beck M, Ricci R, Widmer U, et al. Fabry disease: overall effects of agalsidase alfa treatment. *Eur J Clin Invest* 2004;34(12):838–44.
5. Hughes DA, Elliott PM, Shah J, et al. Effects of enzyme replacement therapy on the cardiomyopathy of Anderson-Fabry disease: a randomised, double-blind, placebo-controlled clinical trial of agalsidase alfa. *Heart* 2008;94(2):153–8.
6. Mehta A, Beck M, Elliott P, et al. Enzyme replacement therapy with agalsidase alfa in patients with Fabry's disease: an analysis of registry data. *Lancet* 2009;374(9706): 1986–96.
7. Nakao S, Takenaka T, Maeda M, et al. An atypical variant of Fabry's disease in men with left ventricular hypertrophy. *N Engl J Med* 1995;333(5):288–93.
8. Sachdev B. Prevalence of Anderson-Fabry disease in male patients with late onset hypertrophic cardiomyopathy. *Circulation* 2002;105(12):1407–11.
9. Chimenti C. Prevalence of Fabry disease in female patients with late-onset hypertrophic cardiomyopathy. *Circulation* 2004;110(9):1047–53.

10. Arad M, Maron BJ, Gorham JM, et al. Glycogen storage diseases presenting as hypertrophic cardiomyopathy. *N Engl J Med* 2005;352(4):362–72.
11. Monserrat L, Gimeno-Blanes JR, Marin F, et al. Prevalence of Fabry disease in a cohort of 508 unrelated patients with hypertrophic cardiomyopathy. *J Am Coll Cardiol* 2007;50(25):2399–403.
12. Hagege AA, Caudron E, Damy T, et al. Screening patients with hypertrophic cardiomyopathy for Fabry disease using a filter-paper test: the FOCUS study. *Heart* 2010;97(2):131–6.
13. Havndrup O, Christiansen M, Stoevring B, et al. Fabry disease mimicking hypertrophic cardiomyopathy: genetic screening needed for establishing the diagnosis in women. *Eur J Heart Fail* 2010;12(6):535–40.
14. Elliott P, Baker R, Pasquale F, et al. Prevalence of Anderson-Fabry disease in patients with hypertrophic cardiomyopathy: the European Anderson-Fabry Disease Survey. *Heart* 2011;97(23):1957–60.
15. Kleinert J, Dehout F, Schwarting A, et al. Prevalence of uncontrolled hypertension in patients with Fabry disease. *Am J Hypertens* 2006;19(8):782–7.
16. Ortiz A, Oliveira JP, Waldek S, et al. Nephropathy in males and females with Fabry disease: cross-sectional description of patients before treatment with enzyme replacement therapy. *Nephrol Dial Transplant* 2008;23(5):1600–7.
17. Linthorst GE, Vedder AC, Aerts JMFG, Hollak CEM. Screening for Fabry disease using whole blood spots fails to identify one-third of female carriers. *Clin Chim Acta* 2005;353(1–2):201–3.
18. Coats AJS, Shewan LG. Statement on authorship and publishing ethics in the *International Journal of Cardiology*. *Int J Cardiol* 2011;153(3):239–40.
19. Lang RM, Bierig M, Devereux RB, et al. Recommendations for chamber quantification. *Eur J Echocardiogr* 2006;7(2):79–108.
20. Chamoles NA, Blanco M, Gaggioli D. Fabry disease: enzymatic diagnosis in dried blood spots on filter paper. *Clin Chim Acta* 2001;308(1–2):195–6.
21. Ploos van Amstel JK, Jansen RP, de Jong JG, Hamel BC, Wevers RA. Six novel mutations in the alpha-galactosidase A gene in families with Fabry disease. *Hum Mol Genet* 1994;3(3):503–5.
22. Nance CS, Klein CJ, Banikazemi M, et al. Later-onset Fabry disease: an adult variant presenting with the cramp-fasciculation syndrome. *Arch Neurol* 2006;63(3):453–7.
23. Mechtler TP, Stary S, Metz TF, et al. Neonatal screening for lysosomal storage disorders: feasibility and incidence from a nationwide study in Austria. *Lancet* 2012;379(9813):335–41.
24. Meikle PJ, Hopwood JJ, Clague AE, Carey WF. Prevalence of lysosomal storage disorders. *JAMA* 1999;281(3):249–54.
25. Linthorst GE, Bouwman MG, Wijburg FA, Aerts JMFG, Poorthuis BJHM, Hollak CEM. Screening for Fabry disease in high-risk populations: a systematic review. *J Med Genet* 2010;47(4):217–22.
26. Spada M, Pagliardini S, Yasuda M, et al. High incidence of later-onset fabry disease revealed by newborn screening. *Am J Hum Genet* 2006;79(1):31–40.
27. Hwu W-L, Chien Y-H, Lee N-C, et al. Newborn screening for Fabry disease in Taiwan reveals a high incidence of the later-onset *GLA* mutation c.936+919G>A (IVS4+919G>A). *Hum Mutat* 2009;30(10):1397–405.
28. Kampmann C, Linhart A, Baehner F, et al. Onset and progression of the Anderson-Fabry disease related cardiomyopathy. *Int J Cardiol* 2008;130(3): 367–73.

29. Patel MR, Cecchi F, Cizmarik M, et al. Cardiovascular events in patients with Fabry disease. *J Am Coll Cardiol* 2011;57(9):1093–9.
30. Gal A, Hughes DA, Winchester B. Toward a consensus in the laboratory diagnostics of Fabry disease — recommendations of a European expert group. *J Inherit Metab Dis* 2011;34(2):509–14.
31. Linhart A, Elliott PM. The heart in Anderson-Fabry disease and other lysosomal storage disorders. *Heart* 2007;93(4):528–35.
32. Andrade J, Waters PJ, Singh RS, et al. Screening for Fabry disease in patients with chronic kidney disease: limitations of plasma alpha-galactosidase assay as a screening test. *Clin J Am Soc Nephrol* 2008;3(1):139–45.



## Attenuated Fabry Disease



**W**e report the phenotype associated with the *GLA* p.Ala143Thr (c.427G>A) mutation in 12 patients aged 42–83 years. We compare our data with literature and data from the Fabry Outcome Survey. We conclude that care should be taken with attribution of vital organ dysfunction (renal failure, stroke and left ventricular hypertrophy) to *GLA* sequence alterations. In case of the p.Ala143Thr mutation, and possibly also other mutations associated with an attenuated phenotype, diagnostic tools such as biopsy and imaging should critically evaluate the relation of end-organ failure with Fabry disease, as this has important consequences for counseling and enzyme replacement therapy.

## **Chapter 3: Contents**

---

### **Paper Four**

**87**

#### ***Questioning the Pathogenic Role of the GLA p.Ala143Thr “Mutation” in Fabry Disease: Implications for Screening Studies and ERT.***

*W. Terryn M.D., R. Vanholder, D. Hemelsoet, B. P. Leroy, W. Van Biesen,  
G. De Schoenmakere, B. Wuyts, K. Claes, J. De Backer, G. De Paepe,  
A. Fogo, M. Praet, B. Poppe*

*JIMD Reports. Volume 8, 2013, pp 101-108.*

## Paper Four

### Questioning the Pathogenic Role of the *GLA* p.Ala143Thr “Mutation” in Fabry Disease: *Implications for Screening Studies and ERT*

*W. Terry M.D., R. Vanholder, D. Hemelsoet, B. P. Leroy, W. Van Biesen, G. De Schoenmakere, B. Wuyts, K. Claes, J. De Backer, G. De Paepe, A. Fogo, M. Praet, B. Poppe*  
*JIMD Reports. Volume 8, 2013, pp 101-108.*

#### **Abstract**

Fabry disease is an X-linked inborn error of glycosphingolipid metabolism caused by quantitative or qualitative defects in the lysosomal enzyme alpha-Galactosidase A ( $\alpha$ -Gal A), ultimately resulting in vital organ dysfunction. Mainly the kidneys, the heart, and the central nervous system are involved. While the classical phenotype of Fabry disease is readily recognizable, screening studies have identified clinical variants. Here, we report the phenotype associated with the *GLA* p.Ala143Thr (c.427G>A) mutation in 12 patients aged 42–83 years. None of the patients had classical Fabry signs or symptoms as angiokeratoma, hypohidrosis, acroparesthesia, or cornea verticillata. Possible Fabry manifestations were renal failure (5/12), stroke (7/12), and left ventricular hypertrophy (5/12), but these were not necessarily attributable to the p.Ala143Thr mutation, as a cardiac biopsy in one female and left ventricular hypertrophy and kidney biopsies in two males with renal failure and microalbuminuria lacked Gb-3 deposits. The literature data on this mutation as well as data collected in the Fabry Outcome Survey (FOS) database confirm these findings. The association of renal failure, stroke, and left ventricular hypertrophy with this mutation could be the result of selection bias, as most patients were detected in screening studies.

We conclude that care should be taken with attribution of vital organ dysfunction to *GLA* sequence alterations. In case of the p.Ala143Thr mutation, and possibly also other mutations associated with an attenuated phenotype, diagnostic tools such as biopsy and imaging should critically evaluate the relation of end-organ failure with Fabry disease, as this has important consequences for enzyme replacement therapy.

## **Introduction**

**F**abry disease (FD, MIM ID #301500) is an X-linked inborn error of glycosphingolipid metabolism caused by quantitative or qualitative defects in the lysosomal enzyme  $\alpha$ -Galactosidase A ( $\alpha$ -Gal A). As a result, glycosphingolipids, mainly globotriaosylceramide (Gb-3), accumulate in different cells throughout the body, ultimately resulting in organ failure (Kint 1970; Brady et al. 1967). Classical FD has been described as a multisystem disease predominantly presenting in males with angiokeratoma, hypohidrosis, and acroparesthesia in childhood, followed by renal failure, left ventricular hypertrophy, stroke, and premature death in the fourth and fifth decade of life. Besides these cases, attenuated forms have been described with a less severe phenotype and a later onset. In males, a specific mutation, associated with a significant residual enzyme activity, can result in a less severe phenotype that presents later in life (e.g., the “cardiac variants”) (NAKAO et al. 1995; Scheidt von Wet al. 1991). In females, residual enzyme activity can be the consequence of skewed X-chromosome inactivation. In the present paper, we present clinical and pathological data on a series of 12 patients with the p.Ala143Thr mutation and compare these data with literature data (9 patients) and data from the Fabry Outcome Survey (FOS) (20 patients).

## **Patients and Methods**

We retrospectively reviewed the charts of patients with the p.Ala143Thr mutation diagnosed in our different screening studies and in the subsequent pedigree analyses (Terry et al. 2008; De Schoenmakere et al. 2008). These studies were conducted according to the World Medical Association Declaration of Helsinki Ethical Principles for Medical Research Involving Human and were approved by the Ethics Institution Review Boards of participating centers. All patients gave written informed consent.

Measurement of  $\alpha$ -Gal A activity was based on a technique involving a dried blood spot sampled on filter paper (DBS) as described by Chamoles et al. (2001). To validate this technique in our laboratory setting, we performed an analysis of 50 control samples (nonnephrology, non-ICU, non-hematology, non-pediatric). In case of low  $\alpha$ -Gal A activity, DBS was repeated in a new blood sample.

In a second part, previously published cases of the p. Ala143Thr mutation were identified through a PubMed search from 1966 to September 6, 2011, entering “p.Ala143Thr”, “A143T”, AND “Fabry Disease” as MESH terms.

A third part of this study consists of the analysis of FOS data. FOS – the Fabry Outcome Survey – is a European outcomes database for patients with Fabry disease who are receiving, or are candidates for, Enzyme Replacement Therapy (ERT) with agalsidase alfa. Data from all consenting patients are entered into the database following a structured clinical assessment by a physician or a specialized nurse. FOS has been approved by the Ethics Institution Review Boards of participating centers and all patients gave written informed consent. All measurements performed routinely in clinical practice are entered into the database.



Anonymous data are submitted electronically by participating physicians to the central FOS database. We summarized baseline available data on all adult (18+) patients with the p.Ala143Thr mutation in this database.

### *Kidney Biopsies*

If kidney biopsies were available, they were reviewed by a local pathologist and by a renal pathologist with expertise in FD (AF). Sections were stained with H & E, PAS, Jones, Congo Red, toluidine blue, and trichrome.

## **Results**

In total, 41 patients with the *GLA* p.Ala143Thr mutation were identified.

Twelve patients (three males and nine females) were detected through our screening studies and subsequent pedigree analysis (Table 3.1). "Classical" symptoms of FD (angiokeratoma, acroparesthesia, cornea verticillata, and hypohydrosis) were absent. A significant number of patients had left ventricular hypertrophy ( $N = 5$ ) or a history of stroke ( $N = 7$ ), but this could be due to a selection bias, as most of these patients were detected as a result of screening studies in populations with left ventricular hypertrophy or stroke (Terry et al. 2008, accepted in the *International Journal of Cardiology*). Of note, residual enzyme function could be demonstrated in all patients. Patient 1, 2, and 5 had a kidney biopsy showing no signs of Fabry nephropathy. Proteinuria and renal failure in patient 1 could be attributed to diabetic nephropathy. Patient 2 was detected as a result of pedigree analysis and despite his low  $\alpha$ -Gal A he had no signs of FD and was asymptomatic besides intermittent paresthesias in both arms, that were aspecific according to an expert neurologist.

One female patient with pronounced left ventricular hypertrophy (LVH) and heart failure (patient 7) had a myocardial biopsy showing AL amyloid and no typical Gb-3 deposition. In our screening studies in high-risk populations (Table 3.2), *GLA* mutations were detected in nine apparently unrelated patients, with seven having the *GLA* p.Ala143Thr mutation.

The cases with p.Ala143Thr from literature are summarized in Table 3.3. Only two patients were diagnosed as the result of symptoms and signs (patient 4 and 7). One patient (patient 7) had a single angiokeratome. A second patient (patient 4) had a cramp-fasciculation syndrome. The other seven patients were diagnosed as the consequence of screening studies and had no typical Fabry symptoms. One male (patient 4) had a kidney biopsy. Typical Fabry inclusions were only noted in a few collecting ducts and distal tubules but not in podocytes or in the endothelium. Another male (patient 9) had a nephrectomy after transplantation because of bilateral renal cell carcinoma. Histological examination of the nonmalignant renal tissue showed chronic glomerulonephritis, hyalinization, and severe arteriosclerosis, but no lesions typical for Fabry disease.

The FOS data are summarized in Table 3.4. Among 1933 registered Fabry patients, 20 adults (12 females and 8 males) from the United Kingdom, Germany, France and Belgium had the p.Ala143Thr mutation. The median baseline eGFR (MDRD) in female patients was 83

Table 3.1. Patients with p.Ala143Thr: own database.

Patient	Age/Gender	Origin of the patient	Angiokeratoma	Acroparesthesia	Hypohidrosis	LVH	Septum/posterior wall thickness (maximal, mm)	Renal involvement	CNS involvement	$\alpha$ GAL A activity in DBS <sup>1</sup>	Kidney biopsy
1	48/m	Index patient - diagnosis as result of screening in LVH	absent	absent	absent	Yes	14	Renal failure, proteinuria	stroke	undetectable, second measurement 0.24, third 0.11	Kimmelstiel Wilson/ no Gb3
2	46/m	Pedigree of pt 6	absent	absent	absent	absent	normal	Micro-albuminuria	absent	Undetectable (second measurement NA)	Normal / no Gb3
3	42/m	Pedigree of pt 6	absent	absent	absent	absent	normal	absent	absent	0.04, second measurement 0.14	NA
4	74/f	Pedigree of pt 1	NA	NA	NA	absent	normal	ESRD	stroke	1.21	NA
5	53/f	Pedigree of pt 1	absent	absent	absent	absent	10.5	absent	NA	0.42	Normal / no Gb3
6	74/f	Index patient - diagnosis as result of screening in hemodialysis	absent	absent	absent	yes	15	ESRD, Nephrotic range proteinuria	stroke	0.19	NA
7	78/f	Index patient - diagnosis as result of screening in LVH	NA	NA	NA	yes	23	Renal failure / proteinuria	NA	NA	Heart: AL amyloid
8	70/f	Index patient - diagnosis as result of screening in LVH	NA	NA	NA	yes	16	absent	absent	0.25	NA
9	83/f	Index patient - diagnosis as result of screening in hemodialysis	absent	absent	absent	yes	20	eGFR 38 mL/min	stroke	0.48	NA
10	54/f	Index patient - diagnosis as result of screening in stroke	absent	absent	absent	absent	normal	normal	Carotis dissection	0.25	NA
11	48/f	Index patient - diagnosis as result of screening in stroke	absent	absent	NA	absent	normal	normal	Stroke	0.89	NA
12	48/f	Index patient - diagnosis as result of screening in stroke	absent	absent	absent	absent	11	eGFR 68 mL/min	Stroke	0.25	NA

<sup>1</sup> normal values: 0.64-3.86  $\mu$ mol/L/h; NA = not available; LVH = Left Ventricular Hypertrophy

**Table 3.2. Screening in high risk groups in Flanders.**

	Females (N)	Muta- tions in females (N) (%)	Males (N)	Muta- tions in males (N) (%)	Total patients (N)	Muta- tions (N) (%)	GLA p.Ala143Thr (c.427G>A)	GLA p.Trp236Arg (c.706T>C)	GLA p.Ala5Glu (c.44C>A)
Hemodialysis <sup>1</sup>	742	2 (0.27%)	180	1 (0.56%)	922	3 (0.33%)	2	1	0
Kidney transplantation <sup>2</sup>	395	0	278	1 (0.36%)	673	1 (0.15%)	1	0	0
Left Ventricular Hypertrophy <sup>3</sup>	178	3 (1.7%)	362	2 (0.55%)	540	5 (0.93%)	4	0	1
<b>Total high risk population</b>	178	5 (0.38%)	820	4 (0.49%)	2135	9 (0.42%)	7 (0.33%)	1 (0.046%)	1 (0.046%)

<sup>1</sup>Wim Terryn et al., Two-Tier Approach for the Detection of Alpha-Galactosidase A Deficiency in a Predominantly Female Haemodialysis Population. *Nephrol Dial Transplant* 23: 294–300, 2008.

<sup>2</sup>Gert De Schoenmakere et al., Two-Tier Approach for the Detection of Alpha-Galactosidase A Deficiency in Kidney Transplant Recipient". *Nephrol Dial Transplant* 23: 4044–4048, 2008.

<sup>3</sup>Wim Terryn et al., Prevalence of Fabry disease in a predominantly hypertensive population with left ventricular hypertrophy. *Int J Cardiol* (accepted June 2012).

mL/min/1.73 m<sup>2</sup> at a mean age of 39. In males, this was 74 mL/min for a median age of 45.

Only limited data were available on the subsequent evolution of kidney function in these patients before ERT was started. In females, median delta eGFR (mL/min/1.73 m<sup>2</sup>/year) was –3.3, which is comparable with literature data on Fabry nephropathy. In males, however, median delta eGFR (mL/min/year) was +1.35 mL/min/1.73 m<sup>2</sup>/year, which is in contradiction with expected kidney function deterioration in Fabry males which is up to –12.2 mL/min/1.73 m<sup>2</sup>/year (Branton et al. 2002).

Many patients (male and female) had micro-albuminuria. Only three had macro-albuminuria (> 300 mg/24 h). The cause of albuminuria was not clear, as only two patients had been biopsied. The male (patient 16) did not show Fabry nephropathy but lupus nephritis, and was successfully treated with immunosuppressive therapy. Stroke was mentioned in only one 80-year-old female (patient 8); at this age, stroke cannot simply be attributed to FD alone.

## Discussion

The p.Ala143Thr mutation is a previously reported missense mutation: resulting from a G to A transition at nucleotide position 247 in exon 3, leading to an Alanine to Threonine substitution and has been reported as being pathogenic (Eng et al. 1997).

The p.Ala143Thr mutation was first reported in 1997 (Eng et al. 1997). The proband was a 1-month-old male infant serendipitously found to have deficient  $\alpha$ -Gal A activity with no family history of FD. It was concluded in the same paper that the phenotype associated with this mutation was unknown. In 2002, this mutation was detected in patients as a result of screening in dialysis patients (Spada 2002 JIMD abstract). In a second abstract (Spada 2003),

Table 3.3. Patients with p.Ala143Thr from literature.

Patient	Age/Sex	Origin of the patients (reference)	Angiokeratoma	Acroparesthesia	Hypohidrosis	LVH	Septum/posterior wall thickness (mm)	Renal involvement	CNS involvement	$\alpha$ GAL A activity	Kidney biopsy
1	84/f	screening in dialysis (ref. 1)	NA	NA	NA	absent	normal	ESRD	NA	NA	NA
2	NA/m	screening in stroke (ref. 2)	NA	NA	NA	NA	NA	NA	Cryptogenic stroke	2.08 (ni: 15.6 $\pm$ 6.2 nmol/hr/mL)	NA
3	74/f	screening in left ventricular hypertrophy (ref. 3)	NA	NA	NA	yes	21	normal	NA	25% of normal mean	NA
4	34/m	clinical diagnosis (ref. 4)	absent	absent	absent	absent	normal	ClCr 160 ml/min Prot 0.1 g/24h	normal	1.9 (ni: 21.6 $\pm$ 6.4 U/L)	Minimal deposits
5	66/f	screening in stroke (ref. 5)	NA	NA	NA	NA	NA	NA	TIA/white matter lesions	NA	NA
6	43/f	screening in stroke (ref. 5)	NA	NA	NA	NA	NA	NA	Stroke Carotids dissection	NA	NA
7	39/m	clinical diagnosis (ref. 6)	One lesion	Absent	Absent	Absent	normal	GFR 70 mL/min	Absent	1.5 $\mu$ mol/L (ni: 3-20)	NA
8	56/f	screening in left ventricular hypertrophy (ref. 7)	absent	absent	absent	Yes	Asymm, max 15 mm	ClCr 58 mL/min	NA	35.1 (ni: 22-56 $\mu$ cat/g protein)	NA
9	67/m	screening in kidney transplant recipients (ref. 8)	absent	absent	absent	yes	yes	ESRD	stroke	"low"	Endstage kidney, bilateral RCC, no Gb3

NA = not available; ESRD = Endstage Renal Disease;

## References

- Spada, M et al. European Symposium on Fabry Disease, 2002:2. A genotype and renal phenotype study in Fabry disease: the A143T genotype correlates with late-onset end-stage renal disease (abstract).
- Wozniak MA, Kittner SJ, Tuhirim S, et al. Frequency of unrecognized Fabry disease among young European-American and African-American men with first ischemic stroke. *Stroke* 2010;41(1):78–81.
- Monserat L, Gimeno-Blanes JR, Marín F, et al. Prevalence of fabry disease in a cohort of 508 unrelated patients with hypertrophic cardiomyopathy. *J Am Coll Cardiol* 2007;50(25):2399–2403.
- Nance CS, Klein CJ, Banikazemi M, et al. Later-onset Fabry disease: an adult variant presenting with the cramp-fasciculation syndrome. *Arch Neurol* 2006;63(3):453–457.
- Brouns R, Thijs V, Eyskens F, et al. Belgian Fabry Study: Prevalence of Fabry Disease in a Cohort of 1000 Young Patients With Cerebrovascular Disease. *Stroke* 2010;41(5):863–868.
- Corry A, Feighery C, Alderdice D, Stewart F, Walsh M, Dolan OM. A family with Fabry disease diagnosed by a single angiokeratoma. *Dermatol Online J* 2011;17(4):5.
- Elliott P, Baker R, Pasquale F, et al (2011) Prevalence of Anderson-Fabry disease in patients with hypertrophic cardiomyopathy: the European Anderson-Fabry Disease Survey. *Heart* 97(23):1957–1960
- Cassiman D, Claes K, Lerut E, et al (2007) Bilateral renal cell carcinoma development in long-term Fabry disease. *J Inher Metab Dis* 30(5):830–831

the same author considered this mutation to be related to late-onset end-stage renal disease. From that time, we read in literature this is a “known pathogenic mutation,” but it was not supported with biopsy data as proof of its pathogenicity. The association of this mutation with renal failure, as in our screening studies (Table 3.2) in renal failure or left ventricular hypertrophy, might thus be the result of selection bias.

*In vitro* expression of this mutant allele in COS 7 cells has been studied (Spada et al. 2006). There is 36 % of expressed  $\alpha$ -Gal A wild-type activity which is in agreement with residual enzyme function in our patients. The finding of a low  $\alpha$ -Gal A activity however is not directly related to FD. We found that the p.Ala143Thr mutation indeed is associated with a low  $\alpha$ -Gal A activity, but its contribution to the phenotype of our patients (stroke, renal failure, left ventricular hypertrophy) is unclear. We performed three kidney biopsies, all lacking typical Gb-3 deposits which are universally present in Fabry patients (Noël et al. 2012). Moreover, among the remaining patients described in this study, we could not find one patient with this mutation and renal failure in whom significant renal Fabry disease was proven by kidney biopsy. In the sphingolipidosis, the ratio of substrate influx into the lysosome and the capacity of the degrading system determines the storage and as such the course and severity of the disease. This is treated in quantitative terms by the so-called threshold theory (Kolter 2011). Only the decrease of enzyme activity below the critical threshold value causes storage of the corresponding lipid substrate. Decrease of enzyme activity to the calculated threshold value does not influence the turnover rate of the substrate (as above this threshold, there is no (linear) relation between enzyme activity and turnover) and pathological storage occurs only below this level. With the exception of acid ceramidase, a decrease of enzyme activity to values of 20 % of normal cells, a typical range for heterozygote carriers of inherited diseases, has no impact on the turnover rate (Kolter 2011).

Our findings corroborate these findings, as we found no deposition of Gb-3 in the lysosomes of the cells of our patients with the p. Ala143Thr mutation. On the basis of the “threshold theory” and the *in vitro* studies of Spada et al. (2006), this could be predicted, as the *in vitro* expression of  $\alpha$ -Gal A in this genotype was 36 % of the wild type expression, which is well over the 20 % mentioned by Kolter 2011.

In FOS, kidney function in patients with p.Ala143Thr remains well preserved in males until their 40s, which is in contradiction with studies on natural history (Branton et al. 2002). Unfortunately, we have no biopsy data in all of these patients, so we cannot ascertain or exclude renal FD in many patients.

Attenuated Fabry phenotypes lacking the classical FD symptoms have been described as a consequence of residual  $\alpha$ -Gal A activity. Some mutations result in residual  $\alpha$ -Gal A activity. This has been described to result in “cardiac variants” that present later in life, with predominantly cardiac manifestations (Scheidt von W et al. 1991). Most of the female patients in this study could be regarded as “variants”; they have significant residual enzyme function, no classical FD symptoms, and mostly cardiac and neurological symptoms.

On the other hand, as FD remains the subject of screening studies in high-risk populations including patients with renal failure and/or stroke, there is a danger of misdiagnosis

**Table 3.4.** FOS data on adult patients with the p.Ala143Thr mutation.

Patient; code FOS	Sex	Age at baseline	$\alpha$ -Gal A (nmol/h/mL) <sup>1</sup>	eGFR before start of ERT (MDRD, mL/min/1.73 m <sup>2</sup> )	Proteinuria before start of ERT (mean) (mg/24 h)	Follow up before ERT (months)	Delta eGFR (mL/min/1.73 m <sup>2</sup> /year)	Kidney biopsy	Stroke	ERT
1	F	32	2.7 <sup>1</sup>	107	165	30	-3.3	No	No	Yes
2	F	55	4.9 <sup>1</sup>	98	230	5	+16.1	No	No	Yes
3	F	21	0.48 <sup>2</sup>	108	61	51	-6.1	No	No	Yes
4	F	29	0.22 <sup>2</sup>	83	102	10	+7.0	No	No	Yes
5	F	33	0.17 <sup>2</sup>	71	107	11	-7.6	No	No	Yes
6	F	38	0.79 <sup>2</sup>	82	110	22	-1.6	No	No	No
7	F	47	NA	71	1802	NA	NA	No	No	Yes
8	F	80	NA	27	NA	30	-5.6	Yes	Yes	No
9	F	51	NA	85	NA	NA	NA	No	No	No
10	F	64	0.69 <sup>2</sup>	67	140	8	-11.5	No	No	Yes
11	F	24	NA	NA	NA	NA	NA	NA	NA	Yes
12	F	40	12 <sup>1</sup>	109	NA	1	+69.5	No	No	No
<b>median</b>	F	39		83			-3.3			
13	M	26	0.5 <sup>3</sup>	177	NA	6	-2.0	No	No	Yes
14	M	62	0.14 <sup>1</sup>	67	303	21	+5.6	No	No	Yes
15	M	52	NA	74	120	10	+4.7	No	No	Yes
16	M	40	0.25 <sup>2</sup>	15	2755	2	+91.3	Yes	No	NA
17	M	68	0.15 <sup>2</sup>	43	185	13	-7.2	No	No	Yes
18	M	44	22 <sup>5</sup>	112	137	NA	-8.0	No	No	Yes
19	M	46	13 <sup>5</sup>	130	128	NA	NA	No	No	Yes
20	M	45	2.4	NA	41 <sup>4</sup>	NA	NA	No	No	Yes
<b>median</b>	M	45		74			+1.35			

<sup>1</sup> (nmol/h/mL) normal values 3.4-13<sup>2</sup> (nU/mg) normal values 0,36-0,84mU/mg<sup>3</sup> measured shortly at birth 1974)<sup>4</sup> mg/g creatinine<sup>5</sup> nmol/MU/mg protein normal >33

NA = not available , MDRD = Modification of Diet in Renal Disease, ERT = Enzyme Replacement Therapy

as a result of selection bias, especially as the p.Ala143Thr mutation was not only detected in screening studies in Belgium (Terry et al. 2008; De Schoenmakere et al. 2008; Brouns et al. 2010) but also in newborn screenings in Italy (Spada et al. 2006), Taiwan (Lin et al. 2009) Austria (Mechtler et al. 2012), and in other screening studies (Monserrat et al. 2007; Elliott et al. 2011).

The prevalence of the p.Ala143Thr mutation in our highrisk populations (0.33 %, Table 3.3) is almost 20 times higher than in a European newborn population (0.017 %, Mechtler et al. 2012). Low  $\alpha$ -Gal A activity could be one cofactor contributing to endothelial stress, provoking stroke, renal failure, or other signs, and symptoms classically associated with FD. The lack of Gb-3 deposits on electron microscopy does not preclude high intracellular

(lyso)-Gb3 levels that could be pathogenic and cause endothelial cell dysfunction (Namdar et al. 2012), though this should be confirmed with further studies.

Despite the coexistence of renal failure, proteinuria, and low  $\alpha$ -Gal A activity in patient 1 from our database (Table 3.1), the diagnosis of Fabry nephropathy was offset by the biopsy that showed a typical case of diabetic nephropathy. Proteinuria and renal failure in patient 16 in the FOS database (Table 3.4) was secondary to lupus nephritis. The cardiac biopsy in patient 7 from our own database (Table 3.1) with LVH and heart failure showed AL amyloid. These examples prove that before accepting the diagnosis of FD, confirmation of a mutation and diminished enzyme activity are needed, as well as comprehensive clinical and pathological workup of the patients, where biopsies of the involved organ, next to other diagnostics tools as MRI in left ventricular hypertrophy, should confirm the diagnosis.

Only two patients with the p.Ala143Thr in FOS were reported to have had a kidney biopsy, in spite of a larger number of patients with renal failure. Nevertheless, most of the included patients were treated with ERT. This expensive treatment is possibly not warranted in these patients.

In stroke, establishing a diagnosis of FD is even more difficult as is the case also in several of our own cases, as biopsy of the affected organ is impossible. Diagnosis is especially difficult when other typical features of FD are lacking, as is the case for the p.Ala143Thr mutation.

It has been proposed by expert panels to start treatment in all adult (>16 years) male Fabry patients, and in all patients, pediatric, male, or female, "as soon as clinical signs and symptoms are observed" (Eng et al. 2006). In our cases, however, we have no knowledge on the contribution of the enzymatic defect to the patients' morbidity and no reliable prognostic data are available on the evolution in case of an "atypical" variant like the p.Ala143Thr. It is even questionable if these patients have Fabry disease at all; it has been suggested to call such mutations, biochemically true positive but clinically false positive, as "fringe mutations" (Houge et al. 2011). Moreover, ERT has been studied in the classical phenotype, but there are no studies on the effects in the atypical variants.

The inclusion of patients with the p.Ala143Thr or other mutations associated with an attenuated phenotype (e.g., N215S or p.Asn215Ser, Branton et al. 2002) in studies on the effectiveness of ERT could confound results and should be studied separately. The place of ERT in patients with the p.Ala143Thr mutation is still unclear and should be the subject of close study. The currently available databases such as the industry-sponsored FOS cannot answer this question. An independent international database with mandatory data collection could provide quality data for further study.

Based on our data, we conclude that the expressivity of the p.Ala143Thr mutation is extremely variable. The presence of this mutation is not to be directly associated with pathology, and we have no compelling data that label this mutation as "pathogenic." At most, it is "possibly" pathogenic. As a consequence, biopsy and clinical data should be collected in order to be able to understand the natural evolution and to decide on the need for ERT.

## References

- Brady R, Gal A, Bradley R, Martensson E, Warshan A (1967) Enzymatic defect in Fabry's disease — ceramide-tetrahexosidase deficiency. *N Engl J Med* 276:1163–1167
- Branton M, Schiffmann R, Kopp JB (2002) Natural history and treatment of renal involvement in Fabry disease. *J Am Soc Nephrol* 13(Suppl 2):S139–143
- Brouns R, Thijs V, Eyskens F et al (2010) Belgian Fabry Study: prevalence of Fabry disease in a cohort of 1000 young patients with cerebrovascular disease. *Stroke; J Cerebral Circulation* 41(5):863–868
- Chamoles NA, Blanco M, Gaggioli D (2001) Fabry disease: enzymatic diagnosis in dried blood spots on filter paper. *Clin Chim Acta* 308(1–2):195–196
- De Schoenmakere G, Poppe B, Wuylts B et al (2008) Two-tier approach for the detection of alpha-galactosidase A deficiency in kidney transplant recipients. *Nephrol Dial Transplant* 23(12): 4044–4048
- Elliott P, Baker R, Pasquale F et al (2011) Prevalence of Anderson- Fabry disease in patients with hypertrophic cardiomyopathy: the European Anderson-Fabry Disease Survey. *Heart* 97(23): 1957–1960
- Eng CM, Ashley GA, Burgert TS, Enriquez AL, D'Souza M, Desnick RJ (1997) Fabry disease: thirty-five mutations in the alpha-galactosidase A gene in patients with classic and variant phenotypes. *Mol Med* 3(3):174–182
- Eng CM, Germain DP, Banikazemi M et al (2006) Fabry disease: guidelines for the evaluation and management of multi-organ system involvement. *Genetics Med* 8(9):539–548
- Houge G, Tøndel C, Kaarbøe Ø, Hirth A, Bostad L, Svarstad E (2011) Fabry or not Fabry – a question of ascertainment. *Eur J Human Genetics* 19(11):1111–1112
- Kint JA (1970) Fabry's disease: alpha-galactosidase deficiency. *Science (New York, NY)* 167(3922):1268–1269
- Kolter T (2011) A view on sphingolipids and disease. *Chem Phys Lipids* 164(6):590–606
- Lin HY, Chong KW, Hsu JH, Yu HC, Shih CC, Huang CH, Lin SJ, Chen CH, Chiang CC, Ho HJ, Lee PC, Kao CH, Cheng KH, Hsueh C, Niu DM (2009) High incidence of the cardiac variant of Fabry disease revealed by newborn screening in the Taiwan Chinese population. *Circ Cardiovasc Genet* 2(5):450–456
- Mechtler TP, Stary S, Metz TF et al (2012) Neonatal screening for lysosomal storage disorders: feasibility and incidence from a nationwide study in Austria. *Lancet* 379(9813):335–341
- Monserrat L, Gimeno-Blanes JR, Marín F et al (2007) Prevalence of Fabry disease in a cohort of 508 unrelated patients with hypertrophic cardiomyopathy. *J Amer College Cardiol* 50 (25):2399–2403
- Nakao S, Takenaka T, Maeda M et al (1995) An atypical variant of Fabry's disease in men with left ventricular hypertrophy. *N Engl J Med* 333(5):288–293
- Namdar M, Gebhard C, Studiger R et al (2012) Globotriaosylsphingosine accumulation and not alpha-galactosidase-a deficiency causes endothelial dysfunction in Fabry disease. *PLoS ONE* 7(4):e36373
- Noël L-H, Laurent B, Gréunfeld J-P (2012) Renal biopsies in Fabry disease: A multicenter French study. *Nephrologie Therapeutique*
- von Scheidt W, Eng CM, Fitzmaurice TF et al (1991) An atypical variant of Fabry's disease with manifestations confined to the myocardium. *N Engl J Med* 324(6):395–399
- Spada M, Pagliardini S (2002) Screening for Fabry Disease in endstage nephropathies. *J Inherit Metab Dis* 25 (Suppl. 1), p 113, Abstract number 226–P



- Spada M, Pagliardini S (2003) Prevalence and characteristics of Fabry disease in nephrology: a lesson from the screening of 6378 male patients on dialysis. *J Inher Metab Dis* 26 (Suppl 2), p. 145, Abstract number 289-O
- Spada M, Pagliardini S, Yasuda M et al (2006) High incidence of later-onset Fabry disease revealed by newborn screening. *Am J Hum Genet* 79(1):31-40
- Terryn W, Poppe B, Wuyts B et al (2008) Two-tier approach for the detection of alpha-galactosidase A deficiency in a predominantly female haemodialysis population. *Nephrol Dial Transplant* 23(1): 294-300





## Screening and Treatment in Chronic Kidney Disease



**F**rom our screening studies in high-risk populations, we conclude that Fabry disease is under-diagnosed in patients with chronic kidney disease. One of the reasons for this is the fact that nephrologists are not familiar with this disease. The European Renal Best Practice (ERBP) is the official guideline body of the European Renal Association/European Dialysis and Transplant Association (ERA/EDTA). The ERBP advisory board considered it useful to develop guidance in the field of rare diseases with nephrological relevance, and invited a group of experts to collaborate in order to develop guidance for nephrologists to diagnose and treat Fabry disease. The following paper is the result of this work: systematic literature review, a consensus meeting with an international panel of experts and peer review.

## **Chapter 4: Contents**

---

### **Paper Five**

**101**

#### ***Fabry nephropathy: indications for screening and guidance for diagnosis and treatment by ERBP.***

*Wim Terry, Pierre Cochat, Roseline Froissart, Alberto Ortiz, Yves Pirson, Bruce Poppe, Andreas Serra, Wim Van Biesen, Raymond Vanholder, Christoph Wanner.*

*Nephrol Dial Transplant. 2012 Dec 12. [Epub ahead of print].*

### **Appendix to Chapter 4:**

**120**

*Patient Information and Informed Consent Form:  
Fabry Disease Screening*

## Paper Five

### Fabry nephropathy: indications for screening and guidance for diagnosis and treatment by ERBP

*Wim Terryn, Pierre Cochat, Roseline Froissart, Alberto Ortiz, Yves Pirson, Bruce Poppe, Andreas Serra, Wim Van Biesen, Raymond Vanholder, Christoph Wanner.  
Nephrol Dial Transplant. 2012 Dec 12. [Epub ahead of print].*

#### **Abstract**

Fabry disease (FD) is an X-linked disorder of glycosphingolipid catabolism resulting in the accumulation of glycolipids including globotriaosylceramide in cells of various tissues resulting in end-organ manifestations. Initially, FD is typically characterized by angiokeratoma and recurrent episodes of neuropathic pain in the extremities occurring during childhood or adolescence. Most affected patients also exhibit a decreased ability to sweat. Later in life, FD results in left ventricular hypertrophy, proteinuria, renal failure and stroke. These later disease manifestations are non-specific and also common in diabetes, hypertension and atheromatosis and thus for most practitioners do not point into the direction of FD. As a consequence, FD is under-diagnosed and screening of high-risk groups is important for case finding, as is a thorough pedigree analysis of affected patients. In the nephrology clinic, we suggest to screen patients for FD when there is unexplained chronic kidney disease in males younger than 50 years and females of any age. In men, this can be performed by measuring  $\alpha$ -galactosidase A activity in plasma, white blood cells or dried blood spots. In women, mutation analysis is necessary, as enzyme measurement alone could miss over one-third of female Fabry patients. A multidisciplinary team should closely monitor all known Fabry patients, with the nephrologist screening kidney impairment (glomerular filtration rate and proteinuria) on a regular basis. Transplanted Fabry patients have a higher mortality than the regular transplant population, but have acceptable outcomes, compared with Fabry patients remaining on dialysis. It is unclear whether enzyme replacement therapy (ERT) prevents deterioration of kidney function. In view of the lack of compelling evidence for ERT, and the low likelihood that a sufficiently powered randomized controlled trial on this topic will be performed, data of all patients with FD should be collected in a central registry.

## **Introduction**

**E**uropean Renal Best Practice (ERBP) is the official guideline body of the European Renal Association/European Dialysis and Transplant Association (ERA/EDTA). The mission of ERBP is to improve the outcome of patients with kidney disease in a sustainable way, through enhancing the accessibility of knowledge on patient care, in a format that stimulates its use in clinical practice. In line with this mission, and in view of its philosophy [1], the ERBP advisory board considered it useful to develop guidance in the field of orphan diseases with nephrological relevance. Typical for these diseases are the rather low patient number, and consequently, the lack of large trials. As a consequence, formal evidence-based medicine is nearly impossible in this field. Nevertheless, nephrologists need guidance on how to approach patients with these diseases. Therefore, ERBP decided to use the combination of formal systematic literature reviews, a consensus meeting with an international panel of experts and peer review as a suitable model to develop guidance in the field of orphan diseases. A first paper on oxalosis has already been published in this series [2]. This paper presents the results of a guidance process on the topic of Fabry disease (FD).

FD (OMIM ID #301500) is an X-linked inborn error of glycosphingolipid catabolism caused by quantitative or qualitative defects in the lysosomal enzyme  $\beta$ -galactosidase A ( $\beta$ -Gal A). As a result, glycosphingolipids, mainly globotriaosylceramide (Gb-3), accumulate in the lysosomes of different cells throughout the body, ultimately resulting in organ failure [3, 4]. Patients with FD have a markedly limited life expectancy due to cardiovascular, neurological and renal involvement. Enzyme replacement therapy (ERT) has been made available since 2001. Intravenous infusion every other week results in the removal of a part of the Gb-3 deposits, diminishes Fabry-related symptoms and possibly protects organs to a certain extent [5, 6]. The effects of ERT on progression of renal disease (proteinuria and renal function) are unclear.

## **Aims of this publication**

The first aim of this paper is to review the current literature on renal disease in Fabry patients, in order to provide guidance to the nephrologist on when to screen for this disease and why, and to understand the preferred methods that should be used for screening.

The second aim is to provide guidance on the follow-up, prevention and treatment of renal disease, and its complications (proteinuria, renal failure). The role of ERT, angiotensin-converting enzyme inhibitors (ACEi), angiotensin receptor blockers (ARB) and renal replacement therapy (RRT) is reviewed.

## **Methods**

A literature search was conducted using the PubMed database (most recent search July 2012). The search term used was 'Fabry Disease' with limits: 'Humans', 'Clinical Trial', 'Meta-Analysis', 'Practice Guideline', 'Randomized Controlled Trial', 'Review', 'English', 'French'. A total of 357 articles were retrieved; the articles were classified to the following topics (one paper can be attributed to more than one classification):

- (i) epidemiology, screening studies;
- (ii) diagnostic methods;
- (iii) Fabry nephropathy: natural history, complications (hypertension), mechanisms, renal pathology;
- (iv) treatment of Fabry nephropathy; with ERT, ACEi and ARB, RRT; efficacy and safety issues.

Articles out of scope and review articles that presented no new data were excluded. Articles on experimental, non-registered treatments were also excluded.

The reference lists of the identified relevant studies were manually searched for additional citations.

After all relevant publications were retrieved, a consensus meeting was held with all co-authors. The resulting paper was sent for internal review before submission, as explained in the 'instructions to authors' section of the ERBP website [7].

## **Epidemiology and the need for screening**

- 1.1 We do not recommend screening in the general population. (Ungraded statement)
- 1.2 We recommend obtaining informed consent from the patient before screening, using an information form drafted in collaboration with a clinical geneticist. (Ungraded statement)
- 1.3 We recommend screening for FD in male chronic kidney disease (CKD) patients below 50 years of age in whom a reliable renal diagnosis is absent. (Ungraded statement)
- 1.4 We suggest screening for FD in females with unexplained CKD, irrespective of age, with other unexplained symptoms potentially associated with FD. (Ungraded statement)
- 1.5 We recommend discussing with the patient the implications of diagnosing a genetic disease and the possible implications for the at-risk relatives. (Level 1C)

### *Rationale*

Classical FD is a progressive multisystem disease predominantly presenting in males, characterized by angiokeratoma, hypohidrosis and acroparesthesia (neuropathic pain) in childhood, followed by renal failure, left ventricular hypertrophy (LVH), stroke and premature death in the fourth or fifth decade of life [8]. In male patients, levels of  $\alpha$ -Gal A activity are classically very low or undetectable. However, as a result of screening studies during the past decade, clinical variants of FD in male patients with varying degrees of residual activity of  $\alpha$ -Gal A have been described. The first described was the 'cardiac variant' with isolated

LVH and/or cardiomyopathy presenting in the sixth or seventh decade, lacking the classical disease symptoms and time course [9, 10]. Patients suffering from this variant may have proteinuria, but their renal function is typically normal for their age. Later a 'renal variant' phenotype was described in a screening study in a dialysis population, where patients again were lacking the classical manifestations. This phenotype was described as 'intermediate' between the cardiac variant and the classic phenotype [11]. These patients with cardiac and renal variants are called 'atypical' or 'attenuated' FD patients. The genetic basis of this variable penetrance and expression is unclear. It is believed that the atypical cases are the result of missense mutations that encode mutant enzyme protein or intronic lesions that reduce transcript levels, both resulting in a reduced but significant residual enzyme function (1–12% of normal) [12], although this has been debated, and others found no genotype–phenotype correlation [13]. Heterozygous women, in spite of having a mutation compatible with typical disease, can also present this attenuated phenotype as it was hypothesized that skewed X-inactivation can result in significant residual enzyme function. However, it must be stressed that most females have the classical phenotype, but with a delayed and/or milder presentation of symptoms [14].

As a consequence, reported prevalence varies with the population studied and the test used for screening, and genetic screening might find female index cases that are not found by enzyme-based methods [15]. The prevalence of classical FD has been estimated at 1 in 117 000 births [14] and 1 in 40 000 males [8]. In several screening studies in high-risk populations, the frequency was up to 1% or even higher, especially in populations with unexplained LVH [16]. In newborns [17–19], the incidence of  $\alpha$ -Gal A deficiency was 1 in 3100 with an 11 to 1 ratio of 2 W. Terry et al. patients with the later-onset versus the classic phenotype. In the haemodialysis population, a prevalence of 0.33% in male and 0.10% in female patients has been found in a cross-sectional screening study [16]. Only two studies screened kidney transplant patients. In cryptogenic stroke, a prevalence of 0.8% [20] up to 2.4% [21] and 3.9% [22] was found; however, in the second study [21], half of the patients had the p.D313Y mutation, which is now generally regarded as a pseudo-deficiency, and in the last study [22], the specific mutations were not mentioned and could also have been polymorphisms. Many screening studies are not conclusive for the female population, as they most frequently used  $\alpha$ -Gal A activity screening, which is in women, as described above, not a sensitive screening tool.

Although there are no studies in the CKD population not on dialysis, we recommend screening for FD in patients with CKD without a clear diagnosis. In classical FD, most males reach CKD Stage 5 or die before the age of 50 [12, 23]. As a consequence, we recommend screening in males only below the age of 50 years. We recommend screening even in the case of a negative family history as de novo mutations can occur, and the family history is not always suggestive for FD, given the broad phenotypic spectrum of the disease. Arterial hypertension should not be an exclusion criterion as more than 50% of FD patients have mild to moderate hypertension, especially when estimated glomerular filtration rate (eGFR) is  $<60$  mL/min/1.73 m<sup>2</sup> [23–25]. In women, disease onset can be later, so when there



is unexplained kidney disease associated with manifestations suggestive of FD, we suggest screening for FD regardless of age.

The real prevalence should be derived from screening in the healthy population at a young age; this has been done in four studies in newborns [17–19, 26]. However, this approach remains problematic for several reasons. The American College of Medical Genetics (ACMG) has proposed newborn screening for 29 disorders, but screening for FD was not included in this list (available online at: <http://mchb.hrsa.gov/screening/>). Although measurement of  $\alpha$ -Gal A has a good sensitivity and specificity in males, it has a low positive predictive value in the healthy population. This will result in unnecessary expensive tests. In addition, the majority of the detected cases in the newborn studies are 'atypical' mutations, giving an attenuated phenotype or a cardiac variant. The finding of a genetic predisposition for a possible late-onset disease where the treatment effectiveness is unclear has ethical and legal implications that constrain a systematic screening of newborns. In these cases, it would be difficult to decide on ERT, as the natural history of patients carrying atypical mutations is poorly characterized, effects of ERT in mild cases have not been studied, and a lifelong treatment is a psychological burden for the patient and a financial one for both the individual and society with, on top of that, uncertain results. As a consequence, we do not recommend screening for FD in the general population.

As FD is an X-linked disease with variable but significant morbidity both in males and females, its diagnosis might have profound consequences for the proband and his relatives. As a consequence, we recommend obtaining informed consent from the proband before screening, when possible in cooperation with an expert in genetic counselling. (Example in Appendix page 120.)

Once the diagnosis is made, it is important to make up a pedigree in order to identify all relatives at risk. FD is an X-linked disease where all carriers can be symptomatic. It should be kept in mind that 'skipping' of a generation is possible because of variable expression.

The patient should receive further guidance in communication with his family. He must be able to provide sufficient information (e.g. by using flyers written by the treating team), and one must anticipate a number of possible problems in the communication with his family. Some people do not want a work-up to the diagnosis of FD, and it should be explained to the patient that they do have the right not to know their genetic status.

## **Screening methods**

2.1 We recommend using enzyme activity measurement for  $\alpha$ -Gal A as a primary tool in males, followed by confirmation with mutation analysis when positive. (Ungraded statement)

2.2 We suggest using mutation analysis as a primary tool for screening in females. (Ungraded statement)

Measurement of  $\alpha$ -Gal A activity in leucocytes using the fluorogenic substrate 4-methylumbelliferyl- $\alpha$ -D-galactopyranoside is the gold standard for FD in men, with a sen-

sitivity and specificity of nearly 100%. Recently, a dried blood spot test (DBS) using filter paper has been proposed as an alternative to the leucocyte tests [27]. These samples are easy to transport and are stable at room temperature for many days, making it a most convenient screening tool in men, as it is a very sensitive tool with a negative predictive value reaching 100%.

In women, due to skewed X inactivation, enzyme activity measurement has a low sensitivity, as one in three women with FD have normal or nearly normal  $\alpha$ -Gal A activity [15]. For this reason, enzymatic tests are less suitable and systematic genetic testing should be encouraged in females with unexplained CKD and manifestations suggestive for FD. As genetic testing is expensive (150–1000 Euro and more per test), a thorough anamnesis, family history and clinical investigation could help to select female CKD patients in whom testing is cost-effective (Figure 4.1).

In FD, gene mutation analysis is a way of confirming diagnosis in male patients, subsequent to enzyme activity measurement. A fresh blood sample can be collected for this purpose, or polymerase chain reaction amplification can be performed on DNA eluted directly from the filter paper used for the DBS  $\alpha$ -Gal A measurement [28]. *GLA* gene mutations causing FD include single base changes leading to missense or nonsense mutations, or affecting

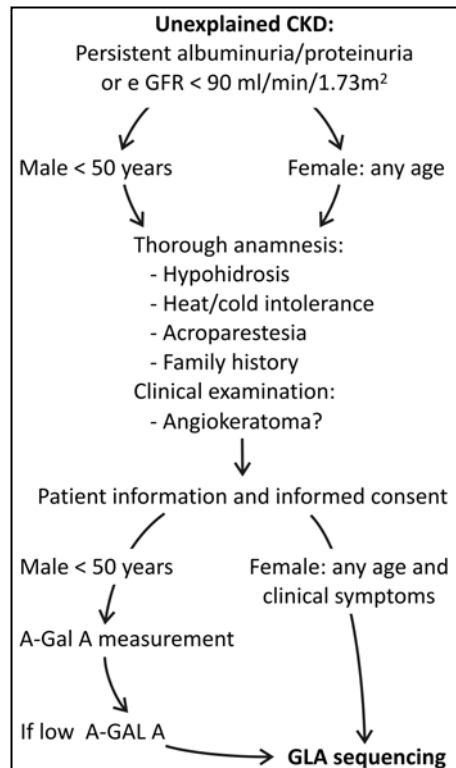

**Figure 4.1.** Flowchart for screening for FD in CKD patients.

consensus splice sites, small deletions or insertions, but also large gene rearrangements in <5% of the patients. Correlations between a specific mutation, i.e. the genotype, and the severity of the disease, the phenotype, are poor in FD. In a few cases, however, knowledge on the underlying mutation can provide information concerning prognosis and therapy and help the clinician in counselling. Some mutations are frequently associated with an attenuated phenotype, such as the mutation p. N215S, which gives a cardiac phenotype with only LVH [29]. These mutations are associated with a residual enzyme function [30]. A significant proportion of the mutations in men are, however, associated with a very low or absent enzyme function and the classic phenotype.

The *GLA* gene should be sequenced. As most of the mutations are 'private', i.e. unique to a family, it is always possible to completely identify a previously undetected mutation, and regular updates of such new mutations are available (<http://www.hgmd.cf.ac.uk/ac/index.php>). The pathogenicity of novel gene alterations such as missense or intronic mutations must always be evaluated. However, in females with normal biochemical tests, it may be difficult to confirm or exclude the diagnosis of FD when a variant of unknown significance is present.

In a suggestive clinical situation, most sequence alterations in exonic regions are pathogenic with very few exceptions. One example of such inert exonic polymorphism is the p. 'D313Y' substitution (G to T at cDNA nucleotide 937); while the plasma enzyme activity towards the artificial substrate is significantly reduced, additional studies demonstrated high residual lysosomal enzyme activity and no pathologic excretion of urinary Gb-3. As a result, the p.D313Y substitution is now generally considered to be a so-called pseudo-deficiency.

If one finds a novel sequence variation in an intronic region or a novel missense mutation that is not known to be a polymorphism present in the general population, several methods allow non-invasive diagnostic analysis to establish whether it is disease causing. First, it should be checked whether these sequence variations exist in the normal population (using electronic databases or an own control population). The second step is to check male relatives of the index case who are carriers of the sequence variation for  $\alpha$ -A activity. If the sequence variation is present in some of them, despite a normal  $\alpha$ -Gal A activity and absence of clinical manifestations of FD, the sequence variation can be considered to be a polymorphism. If it coincides with a deficient  $\alpha$ -Gal A in one or more of the male relatives, the possibility of a disease causing mutation is realistic, and in this case, a work-up of all carriers for the presence of (subclinical) FD disease manifestations should be considered.

Besides enzyme activity measurement and mutation analysis, detection of the accumulating substances (glycosphingolipids) has been studied as a tool for diagnosis. Globotriaosylceramide (Gb-3) is the most important glycosphingolipid, and it should be measured in urine rather than in plasma. Urinary Gb-3 can be a useful diagnostic tool in female heterozygotes with classical FD as it is increased in 95% of them. However, the proportion is much lower in heterozygotes with variant forms. It can also be used in males as a surrogate marker to evaluate the response to ERT [31]. Mass spectrometric profiling of Gb-3 isoforms may also help to identify heterozygotes [32].

In plasma, deacylated Gb-3 (globotriaosylsphingosine, 'lysoGb-3') has been shown to have a better correlation with FD. It is elevated 200–400 times in males with classical disease, from an early phase in the disease, but its levels can remain low in asymptomatic females or in the 'cardiac variant' p.N215S in males [33–37]. The examination of the urinary sediment with phase-contrast microscopy under polarized light shows tubular cells containing particles with birefringent Maltese Crosses, having a lamellated appearance with protrusions, and consisting of accumulated Gb-3. In the hands of Selvarajah et al. [38], this was a highly sensitive and specific tool for screening of FD, but its accuracy is strongly operator-dependent and therefore, it is probably an unrealistic option for large-scale screening studies.

### ***Work-up of a patient with FD***

- 3.1 We recommend that the detailed baseline and followup data of all patients with established FD should be transferred to a central registry. (Ungraded statement)
- 3.2 We recommend baseline and subsequent yearly evaluation by a multidisciplinary team, including kidney function and albuminuria, in all patients with established FD (cardiology, neurology and nephrology). (Ungraded statement)
- 3.3 We recommend not considering female carriers for living donation, unless in exceptional cases. In these cases, we recommend a kidney biopsy to evaluate the risk for the donor and acceptor. (Ungraded statement)

Once an index patient is diagnosed, a baseline evaluation is indicated. As FD is a progressive multisystem disease, baseline evaluation is optimally performed by a multidisciplinary team (Table 4.1, adapted from Eng et al. [39]). The baseline evaluation should be performed in male and all female carriers, as the phenotype can be equally severe.

As this document is written from the nephrology perspective, we will focus on renal involvement in what follows. For evaluation and pathophysiology of other organs, we refer to the guidelines of the respective subspecialties.

Renal involvement is a cardinal feature of FD. Gb-3 deposition in renal cells is progressive and begins early in life. Besides these deposits, pathogenic mechanisms result in glomerular ischaemia with subsequent glomerulosclerosis and tubular atrophy, even very early in the disease course. Vacuolization of podocytes and epithelial cells is a characteristic optical microscopy histological finding. These vacuoles are filled with deposits on electron microscopy, or following toluidine blue staining of samples prepared for electron microscopy. At an early stage, hyperfiltration may, as in diabetes, be the first sign of kidney damage.

As FD can progress subclinically, adolescent and adult patients should have urinary albumin measurement, as this is one of the first signs of Fabry nephropathy. We suggest assessing the amount of albumin normalized for creatinine on a fresh morning sample as diagnostic test. We suggest measuring urinary albumin rather than total protein, as it is more sensitive. Renal function can be assessed using serum creatinine and eventually formulas to translate serum creatinine to estimated clearances. Even in the absence of albuminuria or renal failure, all these parameters should be re-evaluated at least yearly in order to detect

**Table 4.1.** Proposed assessments in FD patients [39].

Organ system	Assessment	Recommendation
<b>General</b>	General status, school or work performance, sports, depression, anxiety, drug use, pedigree update, somatic growth	Baseline (at first visit), every 6 months
	Complete physical examination SF-36®Health Survey, or PedsQL™ Measurement Mode Genetic counselling Genotype	Baseline, every 6 months Baseline, every 6 months for new issues If not previously determined
<b>Kidney</b>	Serum electrolytes, creatinine, BUN; 24-h urine or spot urine for total protein/creatinine, albumin/creatinine, sodium, creatinine	Baseline, every 3 months if CKD Stage 1 or 2 and >1 g/day of proteinuria or CKD Stage 4 Every 6 months if CKD Stage 3 Every 12 months if CKD Stage 1 or 2 and <1 g/day of proteinuria
<b>Cardiac</b>	Palpitations, angina	Baseline, every 6 months
	Blood pressure, rhythm	Every evaluation visit
	ECG, echocardiography 2D with Doppler	Baseline, every other year for patients ≤35 years of age, every year thereafter If an arrhythmia is suspected or palpitations are present
	Holter monitoring, 30-day event monitoring	Optional If clinical signs of angina
<b>Neurologic</b>	Acroparesthesias, fatigue, fever, sweating, heat and cold intolerance, joint pains, stroke-related symptoms, TIA	Baseline, every 6 months
	Neurologic exam, Brief Pain or McGill Pain Inventory	Baseline, every 6 months
	Brain MRI without contrast	Baseline, at the time of a TIA or stroke event or in females to document CNS involvement
	Magnetic resonance angiography	If cerebral vasculopathy should be excluded
	Cold and heat intolerance, pain, vibratory thresholds, sweat output, postganglionic sudomotor function, superficial skin blood flow	When available
Co-morbid stroke risk factors: cholesterol (Total, LDL, HDL), triglycerides	Annually	
Lipoprotein A, total plasma homocysteine, factor V Leiden (G1691A), Protein C, Protein S, prothrombin G20210A, antithrombin III, abtcardiolipin antibody, lupus anticoagulant	At baseline, single assessment	
<b>ENT</b>	Tinnitus, hearing loss, vertigo, dizziness	Baseline, every 6 months
	Audiometry, tympanometry, otoacoustic emissions	Baseline, and yearly thereafter
<b>Ophthalmologic</b>	Visual disturbances, light sensitivity	Baseline, every 6 months
	General ophthalmologic exam (slit-lamp, direct ophthalmoscopy, best corrected visual acuity, visual fields)	Baseline, every 12 months
	Retinal disfunction testing (ERG, colour vision testing, visual-evoked potentials, retinal angiography), tear secretion testing	If clinically indicated
<b>Pulmonology</b>	Cough, exertional dyspnoea, wheezing, exercise intolerance	Baseline, every 6 months
	Spirometry, including response to bronchodilators, treadmill exercise testing, oximetry, chest X-ray	Baseline, every 2 years or more frequently for clinical indications
<b>Gastrointestinal</b>	Postprandial abdominal pain, bloating, diarrhoea, nausea, vomiting, early satiety, difficulty gaining weight	Baseline, every 6 months
	Endoscopic or radiographic evaluations	If symptoms persist or worsen despite treatment
<b>Skeletal</b>	Bone mineral density	Baseline

progressive disease.

Renal intracellular Gb-3 deposits may be present even in young children with normal GFR and minimal or absent micro-albuminuria. In a recent study of 14 young Fabry patients aged 4-19 years with normal GFR, there was an association between the volume of Gb-3 deposition in the podocytes, and age. The volume of Gb-3 deposition was also correlated with urinary protein excretion rates [40]. Tøndel et al. [41] found segmental foot process effacement in all young Fabry patients, despite the fact they were normo-albuminuric (below 30 mg/day). Thus, in the case of patients at risk of FD, any albuminuria, even if in the 'normal' range, should be considered as suspect.

Proteinuria progresses and correlates with and probably also contributes to the decline in renal function, e.g. male Fabry patients with a proteinuria >1 g/24 h had a greater yearly decline in renal function (-6.9 mL/min/1.73 m<sup>2</sup>) than patients with proteinuria between 0.1 and 1 g/24 h (-2.2 mL/min/1.73 m<sup>2</sup>) and patients with proteinuria <0.1 mg/24 h (-0.6 mL/min/1.73 m<sup>2</sup>) [42]. Other studies confirm that the urinary protein to urinary creatinine ratio (UP/Cr) is the most important indicator of renal disease progression [43]. The yearly decline in renal function also correlates with GFR at presentation (in males, -3 mL/min/ 1.73 m<sup>2</sup> with GFR >60 mL/min/1.73 m<sup>2</sup> versus -6.8 mL/min/1.73 m<sup>2</sup> with GFR ! 60 mL/min/1.73 m<sup>2</sup>; in females -0.9 mL/min/1.73 m<sup>2</sup> versus -2.1 mL/min/1.73 m<sup>2</sup>) [42]. Most patients with CKD Stages 3-5 have some degree of proteinuria [23]. Proteinuria in the nephrotic range (>3.5 g/24 h) is, however, rarely seen (maximal 18% in [12]).

CKD Stage 5 usually develops between the third and the fifth decade, with a mean age at diagnosis of 38, but can appear as early as at the age of 16 [44, 45]. Interestingly, the mean age at initiation of RRT is similar for males and females, although the proportion of male versus female FD patients on RRT was 9 to 1 [42].

Living related donation in FD can pose a problem if apparently asymptomatic female carriers consider donating a kidney. Even in the case of a normal renal function and in the absence of albuminuria, significant Gb-3 deposits can be abundant in a renal biopsy [46] and thus female carriers are, in our opinion, not eligible for living kidney donation.

The Fabry population is small and heterogeneous which makes it difficult to study its natural course and to conduct larger-scale, placebo-controlled or open-label clinical trials. For these reasons, a high quality registry with all treated and untreated patients on a European scale, developed independently of industry, is highly desirable.

### ***Treatment of Fabry nephropathy***

- 4.1 We do not recommend starting ERT in patients with proteinuria [ protein-to-creatinine ratio >1 g/g (>0.1 = gram/mol) creatinine] or eGFR <60 mL/min/ 1.73 m<sup>2</sup>, except for non-renal indications. (1D)
- 4.2 We recommend that when ERT is deemed indicated, it should be started as part of a well-designed clinical trial, either observational or interventional. (Ungraded statement)
- 4.3 In a patient on haemodialysis, and when ERT is deemed indicated, we recommend ad-

ministering the ERT during a haemodialysis session. (1A)

4.4 We recommend kidney transplantation as a valuable option in patients who are eligible for this intervention. (Ungraded statement)

4.5 After renal transplantation, we do not suggest ERT for renal indications, but it can be continued for non-renal indications. (Ungraded statement)

As discussed above, proteinuria is an important risk factor for the progression of renal FD. The use of ACE-i and ARB has been shown to be nephro-protective in other proteinuric renal diseases, and could thus be important in FD as well. As such, the use of ACE-i or sartane would be acceptable in FD. In a recent paper [47], it has been demonstrated that ERT interacts with ACE and inhibits its activity, possibly by removing the galactose residues from the enzyme. The clinical relevance of this observation is unclear, and should not be seen as a reason to prohibit the use of ACE-i.

Kidney Disease Improving Global Outcomes (KDIGO) guidelines suggest that in patients with CKD Stages 3–5, vitamin D deficiency be corrected [48]. Emerging evidence in patients with CKD show that vitamin D can reduce proteinuria or albuminuria even in the presence of angiotensin-converting enzyme inhibition [49]. Selective activation of the vitamin D receptor with paricalcitol lowered urinary albumin excretion, as was demonstrated in patients with Type 2 diabetes in a recent randomized controlled trial [50]. In cultured human podocytes, vitamin D receptor activation prevented lyso-Gb-3- induced, TGF $\beta$ 1-mediated, up-regulation of extracellular matrix proteins [51]. Even lacking more definitive evidence of a beneficial effect of vitamin D on Fabry nephropathy, it seems advisable to place particular emphasis in following guidelines on vitamin D management in CKD patients in patients with FD.

Two forms of recombinant  $\alpha$ -Gal A have been approved in Europe: agalsidase alpha (Replagal $^{\circledR}$ ; Shire Human Genetic Therapies, Boston, MA) and agalsidase beta (Fabrazyme $^{\circledR}$ ; Genzyme, Cambridge, MA). Agalsidase alpha is produced in a continuous human cell line and is administered as an intravenous infusion over 40 min at a dose of 0.2 mg/kg body weight every 2 weeks. Agalsidase beta is produced in Chinese hamster ovary (CHO) cells and is given as an intravenous infusion over a 4-h period at a dose of 1.0 mg/kg body weight every 2 weeks.

According to a recent Cochrane review, the evidence base in favour of ERT is weak. Only five (total n = 187) poor quality randomized controlled trials are available. They all concern surrogate end points, such as decrease in plasma Gb-3 levels in plasma and tissues and evolution of renal function. According to the Cochrane review, these studies show no evidence for a clinical benefit of the use of agalsidase alpha or beta to treat Fabry nephropathy [52]. As there are at present no hard data that ERT alters the natural course of Fabry nephropathy (Table 4.2), we recommend starting ERT only in the context of a clinical trial, interventional or observational. All data from observational trials should be entered in a central registry.

Besides randomized controlled trials open-label studies and retrospective analyses have been performed. It is of interest to compare the evolution of renal disease in the historical untreated and treated cohorts of an international industry sponsored registry on FD

**Table 4.2.** Randomized controlled trials in ERT; data concerning the kidney [52].

Comparison I: Agalsidase alpha versus placebo	Agalsidase alpha (n)	Mean (SD)	Placebo (n)	Mean (SD)	Mean difference, 95% CI
Urinary sediment Gb3 Schiffmann 2001 up to 6 months	14	1683 (1657)	11	2495 (1104)	-812,00 (-1897.83, 273.83)
Kidney Gb3 Schiffmann 2001 up to 6 months	14	15.6 (5.98)	11	18.1 (10.54)	-2.5 (-9.47, 4.47)
<i>Creatinine clearance</i> Schiffmann 2001 up to 6 months	13	94.8 (27.76)	1	84.5 (35.15)	10.30 (-15.37, 35.97)
<i>Insulin clearance</i> Schiffmann 2001 up to 6 months	13	71 (16.11)	11	71.5 (32.03)	-0.50 (-21.36, 20.36)
Mesangial widening Schiffmann 2001 up to 6 months	12	25.7 (20.78)	9	40.4 (28.5)	-14.70 (-36.72, 7.32)
Glomeruli with segmental sclerosis Schiffmann 2001 up to 6 months	12	6.8 (8.66)	9	3 (5.7)	3.80 (-2.35, 9.95)
Obsolescent glomeruli Schiffmann 2001 up to 6 months	12	19.5 (20.78)	9	13 (15.3)	6.50 (-8.93, 21.93)
Comparison II: Agalsidase beta versus placebo	Agalsidase beta (n)	Mean (SD)	Placebo (n)	Mean (SD)	Mean difference, 95% CI
Renal microvascular endothelial deposits Eng 2001 up to 6 months	29	0.4 (0.7)	29	2.1 (0.8)	-1.7 (2.09, -1.31)
Renal events Banikazemi 2007 intention-to-treat	10/51	7/31	13	(15.3)	0.87 (0.37, 2.04)

[43, 53]. It is difficult to compare the data presented in both publications, as the design of the analyses and the presentation of data were different, and there was a substantial risk for selection bias, as only a minor proportion of all those enrolled could be evaluated because of missing data. Nevertheless, in both studies, patients were stratified into quartiles according to severity indices of renal involvement. The slope of change in GFR was similar in comparable quartiles of the treated and untreated cohorts, especially in men. Hence, one cannot deny the reflection that ERT might have no marked impact on the decline of kidney function. From this comparison, it is also clear that, irrespective of ERT, proteinuria was the strongest predictor of outcome. In patients without proteinuria, renal function remained stable, equally in males as in females. In those with proteinuria, the slope of deterioration of eGFR appeared to be similar with or without ERT. It is unclear what the implications of these observations are with regard to ERT: either it implies that ERT should be given before proteinuria develops (but these subjects have no deterioration of kidney function anyway) or that it should not be given for renal protection in those with already existing heavy proteinuria. It would be interesting to include complete data sets in a registry of patients developing proteinuria at early stages to see how the evolution of renal function is in this cohort. Remarkably, in the Fabry Registry, data on proteinuria were available in only 462 of 2850 (historical cohort) and 213 of 2887 (ERT cohort) patients [43].

Other observational studies in male FD patients showed that renal function remained



stable under ERT during a follow-up period up to 54 months in the case of normal or near normal baseline function (CKD 1-2) and low proteinuria (<1 g/g creatinine) in the majority of patients [54]. However, as only treated patients were observed, it cannot be excluded that these patients would have had no progression even without therapy, as it is clear from registry data that proteinuria <0.3 g/g creatinine is a favourable prognostic marker. Other publications demonstrate that in FD patients with CKD Stage 4, or with glomerulosclerosis >50% or proteinuria >1 g/g creatinine, renal function continues to deteriorate despite ERT (decline in renal function varying from 6.4 to 8.9 mL/min/1.73 m<sup>2</sup>/year [54, 55]. In the case of CKD Stage 3, the decline in eGFR seems to be attenuated by ERT in comparison with historical data [-3.0 (male) and -1.0 versus -6.8 mL/min/1.73 m<sup>2</sup>/year] [56]. Again, these data are small-scaled and use historic data as controls.

Few studies report on the effect of ERT on renal function in females. In a recent retrospective study of the Fabry Outcome Survey (FOS), the rate of decline in eGFR in females under ERT was similar to the normal expected age-related rate over a 4-year follow-up period, whereas the rate in men was approximately double the expected age-related rate of decline [57]. Another study reported on a stable renal function in female patients treated with ERT [58].

In summary, these studies suggest that, for the renal aspect of FD, treatment is at best only effective in CKD Stage 1 or 2, before the deterioration of renal function or onset of overt proteinuria, as it does not reduce proteinuria per se. Once proteinuria (>1 g/day) or CKD Stage 3 (eGFR <60 mL/min/1.73 m<sup>2</sup>) develops, there are no data supporting a potential protective effect of ERT. Taking this and the very high cost (>200 000 Euro/year) into account, we do not recommend treatment in these cases. ERT has few side effects, except for mild infusion-related reactions consisting primarily of chills that can be treated with paracetamol, antihistamines or steroids. It has been shown that the infusions can be safely performed in a home setting [59, 60].

The administration of ERT leads to the formation of antibodies in the majority of patients, and this is for both brands. These antibodies, especially the IgG, have inhibitory effects on the enzyme activity *in vitro* [5, 6, 61, 62]. Although both agalsidase alpha and agalsidase beta have been associated with IgG formation, the reported incidence of antibodies has generally been higher for agalsidase beta [62]. In a study in 134 males and females, there was no correlation between anti- $\alpha$ -Gal A IgG titres and the onset of clinical events or the rate in change in estimated GFR during treatment. However, a statistically significant association was found between anti- $\alpha$ -Gal A IgG titers and Gb-3 deposition in the dermal capillary endothelial cells during treatment, suggesting that Gb-3 clearance could be impaired [63]. In another study, there was less normalization of urinary Gb-3 in the seropositive patients compared with the seronegative ones [64, 65]. Analysing the consequences of antibodies is challenging because the assays are not uniform and there are no international antibody standards. Currently, numerous laboratories are performing  $\alpha$ -Gal A-antibody testing. Potential differences between antibody assays and their respective sensitivities make comparison of titre values across the Fabry community difficult. The objective of the Fabry Antibody

Standardization Initiative is to identify differences in analytical methods and to standardize I-Gal A antibody assays across the industry to allow the medical community involved in treatment to interpret antibody data equally [66]. We have very few data on the efficiency of higher doses than the ones registered for agalsidase alpha (0.2 mg/kg EOW) and agalsidase beta (1 mg/kg EOW). One open-label trial studied 11 adult male patients with FD who demonstrated a continuing decline in renal function despite 2-4 years of conventionally dosed agalsidase alpha therapy (0.2 mg/kg EOW) [67]. After switching to weekly dosing, three patients demonstrated an improvement in eGFR and six patients demonstrated a slow down in the rate of eGFR decline. Two patients failed to improve their eGFR slope. A multiple regression model confirmed that the weekly infusion regimen was the strongest explanatory variable for the change in eGFR, with a weaker contribution from the concomitant use of angiotensin-converting enzyme inhibitors/ARB, but the patient number was too low to allow meaningful conclusions.

We also have very few data comparing the two formulas. In a study by Vedder et al. [65], the low number of patients and the dose of agalsidase beta that was used (0.2 mg/kg instead of the licensed 1.0 mg/kg) precluded firm conclusions. In a larger group of patients ( $n = 146$ ), there was no difference in a composite outcome of renal, cardiac and neurological events after 30 months of treatment (West, Molecular Genetics and Metabolism, 2011, abstract).

Tahir et al. found stabilization of renal function in a small open-label observational study in patients with CKD Stage 1-2 ( $n = 4$ ) and CKD Stage 3-4 ( $n = 6$ ) treated with a combination of agalsidase beta 1 mg/kg EOW and ACEi or ARB. The surprisingly favourable response in patients with GFR  $<60$  mL/1.73 m<sup>2</sup>/min and proteinuria  $>1$  g/day was unexpected and should be confirmed in a larger study [68]. It is unclear in how far the positive effect, when confirmed, should be attributed to the ACE-i or the ERT.

There is an on-going open-label, prospective, multi-centre study [The Fabrazyme® and ARB's and ACE Inhibitor Treatment (FAACET) Study, registered at ClinicalTrials.gov NCT00446862], with as primary hypothesis that titration of ACEi and ARBs to reduce urine protein excretion to  $<500$  mg/day in Fabry patients receiving agalsidase beta therapy at 1 mg/kg every 2 weeks will slow the progression rate of decline of GFR compared with case-controls drawn from a Genzyme-sponsored Phase III extension study (GFR 60–125 mL/min/1.73 m<sup>2</sup>, urine protein  $>1$  g/day) or the Phase IV study (GFR 20 to 60 mL/min/1.73 m<sup>2</sup>, urine protein  $>0.5$  g/day).

Survival of Fabry patients on RRT is poor, with a reported 3-year survival of 60–63%, which is lower than that of non-diabetic-matched controls [69]. There is no proof of an improved survival in RRT patients on ERT.

In patients with CKD Stage 5, where ERT is deemed to be an appropriate option, ERT can be performed during the haemodialysis sessions, which do not alter pharmacokinetics [70].

ERT diminished extra renal symptoms, and improved quality of life and in CKD Stage 5 patients on dialysis in a small ( $n = 9$ ), non-placebo controlled cross-sectional study [71]. In another observational cross-sectional study ( $n = 16$ ) on dialysis patients, with a mean

follow-up of 45 months of ERT, mortality was very high (7/11), when patients were not transplanted [72]. These limited data suggest that, although typical Fabry symptoms such as pain crises can be controlled with ERT, we have no proof of improvement of cerebrovascular or cardiac morbidity or mortality in CKD Stage 5. Instead, mortality remains high if these patients are not transplanted. Transplantation without ERT has shown acceptable results. In a retrospective study, patient and graft survival was good for the first 10 years, although this study was probably undertaken in a selected patient group with little co-morbidity. After 10 years, mortality increases very quickly, probably due to progression of FD [73]. Data from the organ procurement Transplant Network/United Network for Organ Sharing (n = 197) were compared with a matched cohort of non-Fabry and non-diabetic CKD Stage 5 patients; although 5-year graft survival was similar, Fabry patients had a higher risk of death [RR 2.15 (1.52–3.02)] [74]. All these data seem to indicate that transplantation can be successful in patients with Fabry nephropathy, and that transplanted patients have a stable kidney function without ERT.

## References

1. Zoccali C, Abramowicz D, Cannata-Andia JB et al. European best practice quo vadis? From European Best Practice Guidelines (EBPG) to European Renal Best Practice (ERBP). *Nephrol Dial Transplant* 2008; 23: 2162–2166
2. Cochat P, Hulton S-A, Acquaviva C et al. Primary hyperoxaluria Type 1: indications for screening and guidance for diagnosis and treatment. *Nephrol Dial Transplant* 2012; 27: 1729–1736
3. Kint JA. Fabry's disease: alpha-galactosidase deficiency. *Science* 1970; 167: 1268–1269
4. Brady R, Gal A, Bradley R et al. Enzymatic defect in Fabry's disease – ceramidetrihexosidase deficiency. *N Engl J Med* 1967; 276: 1163–1167
5. Eng CM, Guffon N, Wilcox WR et al. Safety and efficacy of recombinant human alpha-galactosidase A – replacement therapy in Fabry's disease. *N Engl J Med* 2001; 345: 9–16
6. Schiffmann R, Kopp JB, Austin HA et al. Enzyme replacement therapy in Fabry disease: a randomized controlled trial. *JAMA* 2001; 285: 2743–2749
7. [www.european-renal-best-practice.org](http://www.european-renal-best-practice.org)
8. Scriver CR. *The Metabolic & Molecular Bases of Inherited Disease*. 8th edition. McGraw-Hill, New York, 2001.
9. Scheidt von W, Eng CM, Fitzmaurice TF et al. An atypical variant of Fabry's disease with manifestations confined to the myocardium. *N Engl J Med* 1991; 324: 395–399
10. Nakao S, Takenaka T, Maeda M et al. An atypical variant of Fabry's disease in men with left ventricular hypertrophy. *N Engl J Med* 1995; 333: 288–293
11. Nakao S, Kodama C, Takenaka T et al. Fabry disease: detection of undiagnosed hemodialysis patients and identification of a 'renal variant' phenotype. *Kidney Int* 2003; 64: 801–807
12. Branton M, Schiffmann R, Kopp JB. Natural history and treatment of renal involvement in Fabry disease. *J Am Soc Nephrol* 2002; 13 (Suppl 2): S139–S143

13. Altarescu GM, Goldfarb LG, Park KY et al. Identification of fifteen novel mutations and genotype–phenotype relationship in Fabry disease. *Clin Genet* 2001; 60: 46–51
14. Germain DP. Fabry disease. *Orphanet J Rare Dis* 2010; 5: 30
15. Linthorst GE, Vedder AC, Aerts JMFG et al. Screening for Fabry disease using whole blood spots fails to identify one-third of female carriers. *Clin Chim Acta* 2005; 353: 201–203
16. Linthorst GE, Bouwman MG, Wijburg FA et al. Screening for Fabry disease in high-risk populations: a systematic review. *J Med Genet* 2010; 47: 217–222
17. Spada M, Pagliardini S, Yasuda M et al. High incidence of later onset Fabry disease revealed by newborn screening. *Am J Hum Genet* 2006; 79: 31–40
18. Hwu W-L, Chien Y-H, Lee N-C et al. Newborn screening for Fabry disease in Taiwan reveals a high incidence of the later-onset *GLA* mutation c.936+919G>A (IVS4+919G>A). *Hum Mutat* 2009; 30: 1397–1405
19. Lin H-Y, Chong K-W, Hsu J-H et al. High incidence of the cardiac variant of Fabry disease revealed by newborn screening in the Taiwan Chinese population. *Circ Cardiovasc Genet* 2009; 2: 450–456
20. Brouns R, Thijs V, Eyskens F et al. Belgian Fabry study: prevalence of Fabry disease in a cohort of 1000 young patients with cerebrovascular disease. *Stroke* 2010; 41: 863–868
21. Baptista MV, Ferreira S, Pinho-e-Melo T et al. Mutations of the *GLA* gene in young patients with stroke: the PORTYSTROKE study—screening genetic conditions in PORTuguese young STROKE patients. *Stroke* 2010; 41: 431–436
22. Rolfs A, Böttcher T, Zschiesche M et al. Prevalence of Fabry disease in patients with cryptogenic stroke: a prospective study. *Lancet* 2005; 366: 1794–1796
23. Ortiz A, Oliveira JP, Waldek S et al. Nephropathy in males and females with Fabry disease: cross-sectional description of patients before treatment with enzyme replacement therapy. *Nephrol Dial Transplant* 2008; 23: 1600–1607
24. Kleinert J, Dehout F, Schwarting A et al. Prevalence of uncontrolled hypertension in patients with Fabry disease. *Am J Hypertens* 2006; 19: 782–787
25. Terryn W, Deschoenmakere G, De Keyser J et al. Prevalence of Fabry disease in a predominantly hypertensive population with left ventricular hypertrophy. *Int J Cardiol* 2012 Jul 15. [Epub ahead of print]
26. Mechtler TP, Stary S, Metz TF et al. Neonatal screening for lysosomal storage disorders: feasibility and incidence from a nationwide study in Austria. *Lancet* 2012; 379: 335–341
27. Olivova P, Veen der KV, Cullen E et al. Effect of sample collection on  $\alpha$ -galactosidase A enzyme activity measurements in dried blood spots on filter paper. *Clin Chim Acta* 2009; 403: 159–162
28. Hagege AA, Caudron E, Damy T et al. Screening patients with hypertrophic cardiomyopathy for Fabry disease using a filter-paper test: the FOCUS study. *Heart* 2010; 97: 131–136
29. Eng CM, Desnick RJ. Molecular basis of Fabry disease: mutations and polymorphisms in the human  $\alpha$ -galactosidase A gene. *Hum Mutat* 1994; 3: 103–111
30. Elstein D, Altarescu G, Beck M. *Fabry Disease*. Springer Dordrecht Heidelberg London New York: Springer, 2010
31. Gal A, Hughes DA, Winchester B. Toward a consensus in the laboratory diagnostics of Fabry disease—recommendations of a European expert group. *J Inherit Metab Dis* 2011; 34: 509–514

32. Paschke E, Fauler G, Winkler H et al. Urinary total globotriaosylceramide and isoforms to identify women with Fabry disease: a diagnostic test study. *Am J Kidney Dis* 2011; 57: 673–681
33. Vedder AC, Linthorst GE, van Breemen MJ et al. The Dutch Fabry cohort: diversity of clinical manifestations and Gb3 levels. *J Inher Metab Dis* 2007; 30: 68–78
34. van Breemen MJ, Rombach SM, Dekker N et al. Reduction of elevated plasma globotriaosylsphingosine in patients with classic Fabry disease following enzyme replacement therapy. *Biochim Biophys Acta* 2011; 1812: 70–76
35. Auray-Blais C, Ntwari A, Clarke JTR et al. How well does urinary lyso-Gb3 function as a biomarker in Fabry disease? *Clin Chim Acta* 2010; 411: 1906–1914
36. Togawa T, Kawashima I, Kodama T et al. Tissue and plasma globotriaosylsphingosine could be a biomarker for assessing enzyme replacement therapy for Fabry disease. *Biochem Biophys Res Commun* 2010; 399: 716–720
37. Rombach SM, Dekker N, Bouwman MG et al. Plasma globotriaosylsphingosine: diagnostic value and relation to clinical manifestations of Fabry disease. *Biochim Biophys Acta* 2010; 1802: 741–748
38. Selvarajah M, Nicholls K, Hewitson TD et al. Targeted urine microscopy in Anderson–Fabry disease: a cheap, sensitive and specific diagnostic technique. *Nephrol Dial Transplant* 2011; 26: 3195–3202
39. Eng CM, Germain DP, Banikazemi M et al. Fabry disease: guidelines for the evaluation and management of multi-organ system involvement. *Genet Med* 2006; 8: 539–548
40. Najafian B, Svarstad E, Bostad L et al. Progressive podocyte injury and globotriaosylceramide (GL-3) accumulation in young patients with Fabry disease. *Kidney Int* 2010; 79: 663–670
41. Tøndel C, Bostad L, Hirth A et al. Renal biopsy findings in children and adolescents with Fabry disease and minimal albuminuria. *Am J Kidney Dis* 2008; 51: 767–776
42. Schiffmann R, Warnock DG, Banikazemi M et al. Fabry disease: progression of nephropathy, and prevalence of cardiac and cerebrovascular events before enzyme replacement therapy. *Nephrol Dial Transplant* 2009; 24: 2102–2111
43. Wanner C, Oliveira JP, Ortiz A et al. Prognostic indicators of renal disease progression in adults with Fabry disease: natural history data from the Fabry registry. *Clin J Am Soc Nephrol* 2010; 5: 2220–2228
44. Meehan SM, Junsanto T, Rydel JJ et al. Fabry disease: renal involvement limited to podocyte pathology and proteinuria in a septuagenarian cardiac variant. Pathologic and therapeutic implications. *Am J Kidney Dis* 2004; 43: 164–171
45. Ortiz A, Cianciaruso B, Cizmarik M et al. End-stage renal disease in patients with Fabry disease: natural history data from the Fabry Registry. *Nephrol Dial Transplant* 2010; 25: 769–775
46. Kochar O, Wick MR, Kerr SE et al. Unexpected Fabry disease in a renal allograft kidney: an underrecognized cause of poor allograft function. *Ultrastruct Pathol* 2011; 35: 92–96
47. Batista EC, Carvalho LR, Casarini DE et al. ACE activity is modulated by the enzyme  $\beta$ -galactosidase A. *J Mol Med* 2010; 89: 65–74
48. Kidney Disease: Improving Global Outcomes (KDIGO) CKD-MBD Work Group. KDIGO clinical practice guideline for the diagnosis, evaluation, prevention, and treatment of Chronic Kidney Disease–Mineral and Bone Disorder (CKD-MBD). *Kidney Int Suppl* 2009; S1–S130

49. Agarwal R. Vitamin D, proteinuria, diabetic nephropathy, and progression of CKD. *Clin J Am Soc Nephrol* 2009; 4: 1523–1528
50. de Zeeuw D, Agarwal R, Amdahl M et al. Selective vitamin D receptor activation with paricalcitol for reduction of albuminuria in patients with type 2 diabetes (VITAL study): a randomised controlled trial. *Lancet* 2010; 376: 1543–1551
51. Sanchez-Niño MD, Sanz AB, Carrasco S et al. Globotriaosylsphingosine actions on human glomerular podocytes: implications for Fabry nephropathy. *Nephrol Dial Transplant* 2011; 26: 1797–1802
52. Dib El RP, Pastores GM. Enzyme replacement therapy for Anderson–Fabry disease. *Cochrane Database Syst Rev* 2010; CD006663
53. Warnock DG, Ortiz A, Mauer M et al. Renal outcomes of agalsidase beta treatment for Fabry disease: role of proteinuria and timing of treatment initiation. *Nephrol Dial Transplant* 2012; 27: 1042–1049
54. Germain DP, Waldek S, Banikazemi M et al. Sustained, long-term renal stabilization after 54 months of agalsidase beta therapy in patients with Fabry disease. *J Am Soc Nephrol* 2007; 18: 1547–1557
55. West M, Nicholls K, Mehta A et al. Agalsidase alfa and kidney dysfunction in Fabry disease. *J Am Soc Nephrol* 2009; 20: 1132–1139
56. Mehta A, Beck M, Elliott P et al. Enzyme replacement therapy with agalsidase alfa in patients with Fabry's disease: an analysis of registry data. *Lancet* 2009; 374: 1986–1996
57. Hughes DA, Barba Romero M-Á, Hollak CEM et al. Response of women with Fabry disease to enzyme replacement therapy: comparison with men, using data from FOS—the Fabry Outcome Survey. *Mol Genet Metab* 2011; 103: 207–214
58. Baehner F, Kampmann C, Whybra C et al. Enzyme replacement therapy in heterozygous females with Fabry disease: results of a phase IIIB study. *J Inherit Metab Dis* 2003; 26: 617–627
59. Schiffmann R. Long-term therapy with agalsidase alfa for Fabry disease: safety and effects on renal function in a home infusion setting. *Nephrol Dial Transplant* 2005; 21: 345–354
60. Linthorst GE, Vedder AC, Ormel EE et al. Home treatment for Fabry disease: practice guidelines based on 3 years experience in The Netherlands. *Nephrol Dial Transplant* 2006; 21: 355–360
61. Linthorst GE, Hollak CEM, Donker-Koopman WE et al. Enzyme therapy for Fabry disease: neutralizing antibodies toward agalsidase alpha and beta. *Kidney Int* 2004; 66: 1589–1595
62. Deegan PB. Fabry disease, enzyme replacement therapy and the significance of antibody responses. *J Inherit Metab Dis* 2012; 35: 227–243
63. Bénichou B, Goyal S, Sung C et al. A retrospective analysis of the potential impact of IgG antibodies to agalsidase " on efficacy during enzyme replacement therapy for Fabry disease. *Mol Genet Metab* 2009; 96: 4–12
64. Ohashi T, Sakuma M, Kitagawa T et al. Influence of antibody formation on reduction of globotriaosylceramide (GL-3) in urine from Fabry patients during agalsidase beta therapy. *Mol Genet Metab* 2007; 92: 271–273
65. Vedder AC, Breunig F, Donker-Koopman WE et al. Treatment of Fabry disease with different dosing regimens of agalsidase: effects on antibody formation and GL-3. *Mol Genet Metab* 2008; 94: 319–325
66. Schellekens H. The immunogenicity of therapeutic proteins and the Fabry antibody standardization initiative. *Clin Ther* 2008; 30(Suppl B): S50–S51

67. Schiffmann R, Askari H, Timmons M et al. Weekly enzyme replacement therapy may slow decline of renal function in patients with Fabry disease who are on long-term biweekly dosing. *J Am Soc Nephrol* 2007; 18: 1576–1583 10 W. Terryn et al. Downloaded from <http://ndt.oxfordjournals.org/> at Ghent University on January 11, 2013
68. Tahir H, Jackson LL, Warnock DG. Antiproteinuric therapy and Fabry nephropathy: sustained reduction of proteinuria in patients receiving enzyme replacement therapy with agalsidase-beta. *J Am Soc Nephrol* 2007; 18: 2609–2617
69. Thadhani R, Wolf M, West ML et al. Patients with Fabry disease on dialysis in the United States. *Kidney Int* 2002; 61: 249–255
70. Pastores GM, Boyd E, Crandall K et al. Safety and pharmacokinetics of agalsidase alfa in patients with Fabry disease and end-stage renal disease. *Nephrol Dial Transplant* 2007; 22: 1920–1925
71. Pisani A, Spinelli L, Sabbatini M et al. Enzyme replacement therapy in Fabry disease patients undergoing dialysis: effects on quality of life and organ involvement. *Am J Kidney Dis* 2005; 46: 120–127
72. Mignani R, Feriozzi S, Pisani A et al. Agalsidase therapy in patients with Fabry disease on renal replacement therapy: a nationwide study in Italy. *Nephrol Dial Transplant* 2008; 23: 1628–1635
73. Inderbitzin D, Avital I, Largiader F et al. Kidney transplantation improves survival and is indicated in Fabry's disease. *Transplant Proc* 2005; 37: 4211–4214
74. Shah T, Gill J, Malhotra N et al. Kidney transplant outcomes in patients with Fabry disease. *Transplantation* 2009; 87: 280–285

## **APPENDIX TO CHAPTER 4:**

### **PATIENT INFORMATION AND INFORMED CONSENT FORM: *FABRY DISEASE SCREENING***

---

**Y**our treating nephrologist would like to do a test for Fabry disease. This is a rare inherited condition that causes signs and symptoms that can range from mild to severe to even life threatening. In people with Fabry disease, the enzyme alpha-galactosidase A (or  $\alpha$ -Gal A) that helps the body to break down a fatty substance called globotriaosylceramide or Gb-3 is insufficiently present. Without enough of this enzyme, the Gb-3 substance builds up in kidney cells and in the cells of other organs and may cause severe kidney problems, including kidney failure.

#### ***Signs and Symptoms***

Because Fabry disease is rare and not always well recognized, its symptoms are sometimes overlooked or attributed to other more common conditions. There are, however, a number of signs and symptoms that people with Fabry disease typically experience from a young age:

- Burning, tingling pain in the hands and feet
- Impaired sweating
- Heat/cold intolerance
- Skin rashes (angiokeratoma)
- Hearing problems
- Gastrointestinal problems, such as diarrhea or vomiting
- Heart problems (including enlarged heart and arrhythmia)
- Kidney problems
- Nervous system problems, such as stroke
- Psychological issues, such as depression

Signs and symptoms may present in childhood, but because physicians often do not attribute these symptoms to Fabry disease, patients may not be diagnosed until adulthood.

Fabry disease is a progressive disorder; therefore it can be important that patients be identified as early as possible.

Fabry disease is a genetic disease passed down (or inherited) from parents to children. The Fabry gene is located on the X chromosome. As a consequence, a father with Fabry disease will pass the gene onto all of his daughters and none of his sons. As women have two X chromosomes, they sometimes experience a less severe disease than men. If a mother carries the Fabry gene, there is a 50% risk that she will pass the gene onto her sons or daughters. Fabry disease can affect anyone who inherits the mutated gene - both males and



females. Virtually all males with the Fabry gene develop the disease and are likely to express some or many of the classic Fabry symptoms. In women with the Fabry gene, however, symptoms can range from none (in asymptomatic carriers) to very serious manifestations similar to those seen in males.

### ***Testing for Fabry disease***

Nephrologists (kidney specialists) are advised to screen for Fabry disease in patients with renal failure or proteinuria (= having a significant amount of protein in the urine). The test is done by means of a simple blood sample.

### ***Genetic Counseling***

If you have been diagnosed with Fabry disease, you know that some of your family members could also have the disease. In order to deal with this information, you may benefit from the support of a genetic counselor. Genetic counselors are professionals who can help you learn more about the disease and assist you with issues such as disease inheritance, family planning, genetic testing, and communicating with family members about your diagnosis. As Fabry disease can present itself with a wide range of symptoms, from very mild to very severe and even life threatening, and as there is no efficient treatment available that can stop the disease, some people might not want to know they have the disease or not. It is important to know that people have the right not to know whether or not they have the disease. This decision can also impact on their family, as also other family members can be affected. The genetic counselor can help you understand the disease and its impact on your life and of your family.

***Informed consent***

I hereby declare that I consent with a genetic analysis for Fabry disease. No other genetic analysis will performed on my blood or DNA sample without my permission.

I had the possibility to ask questions to dr. .... and I have received answers that I can comprehend. When the results of the genetic analysis are available, I will be invited to discuss the results. The results of the genetic analysis will be communicated to me at the occasion of a medical consultation. When the results are available, I still have the opportunity to refuse to be confronted with the results of the genetic analysis. The results of the genetic analysis will not be communicated to other parties, without my prior consent.

If the genetic analysis does not reveal a pathogenic mutation, I consent to future genetic analysis for novel genetic aberrations that might explain a genetic predisposition for Fabry disease. When these results have relevant medical implications for me or for my relatives, I will be invited to the consultation to discuss these results.

Date.....

Physician.....

Patient.....

Completed in duplicate, of which I have received one copy.

## *Chapter 5*



### General Discussion and Perspectives





## General Discussion

The first aim of this thesis was to study the prevalence of Fabry disease. We hypothesized that Fabry disease was under-ascertained. The low prevalence of the disease, variability in clinical expression and lack of highly specific symptoms preclude an easy diagnosis by clinicians. In addition, as Fabry disease is a progressive disease, an early diagnosis is important, as treatment has to be initiated before the onset of irreversible organ damage. For these reasons, the study of the prevalence and the detection of index cases and their subsequent pedigree analysis seemed an important goal. This prompted us to screen in high-risk populations.

In total, we screened 2135 patients belonging to three high-risk populations: hemodialysis patients, kidney transplant recipients and patients with left ventricular hypertrophy (Table 5.1). We found 9 index cases. The overall prevalence of *GLA* mutations was 0.42 % (1 in 237) in high-risk patients. Only one of these patients had been previously diagnosed with Fabry disease. Seven (78%) (Table 5.2) of these patients had the *GLA* p.Ala143Thr (c.427G>A) mutation, which is associated with an attenuated phenotype (Chapter 3). The other two mutations were associated with a classic Fabry phenotype. *GLA* p.Ala5Glu (c.44C>A) had not been described up to now in literature and the diagnosis of Fabry disease had not yet been made before the screening took place.

**Table 5.1.** Screening in high risk groups in Flanders.

	Hemodialysis	Kidney transplantation	Left Ventricular Hypertrophy	Total high risk population
<b>Females screened</b>	742	395	178	1315
<b>Mutation in females, N (%)</b>	2 (0.27%)	0	3 (1.7%)	5 (0.38%)
<b>Males screened</b>	180	278	362	820
<b>Mutation in males, N (%)</b>	1 (0.56%)	1 (0.36%)	2 (0.55%)	4 (0.49%)
<b>Total patients</b>	922	673	540	2135
<b>Mutations, N (%)</b>	3 (0.33%)	1 (0.15%)	5 (0.93%)	9 (0.42%)

**Table 5.2.** *GLA* mutations detected in screening studies in high-risk populations in Flanders.

	Hemodialysis	Kidney transplantation	Left Ventricular Hypertrophy	Total high risk population N (%)
<b><i>GLA</i> p.Ala143Thr</b> (c. 427G>A)	2	1	4	7 (0.33%)
<b><i>GLA</i> p.Trp236Arg</b> (c.706T>C)	1	0	0	1 (0.046 %)
<b><i>GLA</i> p.Ala5Glu</b> (c.44C>A)	0	0	1	1 (0.046 %)

With other screening studies, our studies demonstrate that Fabry disease is under-ascertained and much more prevalent than previously assumed, but this high prevalence is for a large part due to attenuated cases and less to classical Fabry disease. Classical Fabry disease was also under-ascertained, as exemplified by one of the two cases in our study, despite the fact that the patient had a typical phenotype and a positive family history.

We conclude that screening of high-risk groups is efficient, as it permits to detect and counsel Fabry patients at reasonable cost. Our strategy to screen in hemodialysis patients who have no evident renal diagnosis has already been copied by the NBVN (Nederlandstalige Belgische Vereniging Nefrologie). Next, we have made recommendations for nephrologists to screen for Fabry disease in Chronic Kidney Disease. In collaboration with European Fabry experts, we now recommend to screen for Fabry disease in patients with unexplained Chronic Kidney Disease, which is defined as persistent albuminuria/proteinuria or an eGFR <90 ml/min/1.73m<sup>2</sup>. In males we recommend to screen under the age of 50, as the goal is the detection of classical Fabry disease and not that of the attenuated phenotypes. This has been published as a “European Best Practice Guideline (ERBP)” (Chapter 4).

We should, however, remain cautious and critical. It is clear that in many of the cases detected in the screening studies, the mutation is associated with an atypical or attenuated phenotype and natural history and effects of treatment will be anything but predictable. In Flanders, the *GLA* p.Ala143Thr (c.427G>A) mutation seems to have a high prevalence. This is also the case in Austria, as 6 of the 9 cases of Fabry disease detected in a newborn screening [1] had this mutation. This mutation was up to now labelled as “associated with an attenuated phenotype”, so we studied it in 41 patients among our index cases and their families and in cases described in literature and cases registered in the Fabry Outcome Survey (Chapter 3). This mutation indeed seems to be associated with a low or absent  $\alpha$ -Gal A activity but we found little convincing evidence that this mutation is disease-causing, as biopsies of kidney, heart and skin could not show typical Fabry pathology. The morbidity in our patients with this “mutation” (chronic kidney disease and left ventricular hypertrophy) could not directly be attributed to Fabry disease, and could be the result of ascertainment bias. This mutation was however more prevalent in our high risk population (0.33 %) compared to a general population screening in Austria (0.026 %) [1], so this mutation might be one among other contributors to our patients morbidity. We plan to set up a database on all patients with p.Ala143Thr (c.427G>A) in order to prospectively study its natural history (is there progressive Gb-3 deposition, and organ damage as a consequence?) and the effect of enzyme replacement and other therapies, so that in the future, we can make evidence-based recommendations.

During the progress of our studies, we optimised our screening methods. The method we initially used for screening in males and females was the determination of  $\alpha$ -Gal A activity using a blood spot test. This test using filter paper was described by Chamois et al. [2] and validated in our laboratory setting using blood samples from non-nephrology, non-ICU, non-hematology and non-pediatric patients. Patients with a confirmed  $\alpha$ -Gal A activity

below the sixth percentile then entered the second level of a two-tier approach, which was mutation analysis.  $\alpha$ -Gal A activity measurement is very sensitive in males, but proves not to be sensitive in females [3], hence we decided to use *GLA* mutation analysis for the female patients in our subsequent study on the screening for Fabry disease in patients with left ventricular hypertrophy [4]. Specificity of  $\alpha$ -Gal A activity measurement is low, as we had up to 3% (false) positives even with correct internal validation with  $\alpha$ -Gal B (data not published); in case of low  $\alpha$ -Gal A activity, the diagnosis of Fabry disease should be confirmed with a repeated measurement of  $\alpha$ -Gal A activity (in males) and/or mutation analysis.

We further evaluated renal outcomes and treatment options by means of a systematic literature search. We assessed data on enzyme replacement therapy and survival on renal replacement therapy (dialysis and transplantation). The result of this systematic search is part of the paper for ERBP mentioned above (Chapter 4). We conclude that only very few hard data support a significant effect of enzyme replacement therapy. Only five small randomized controlled trials (RCTs) are available. Significant effects concern surrogate endpoints, such as the decrease of plasma Gb-3 levels and tissue depositions. In these trials, the effects on morbidity and mortality was statistically not significant and more specifically, these studies show no evidence for a clinical benefit of the use of agalsidase alfa or beta to treat Fabry nephropathy. Observational trials suggest that, for the renal aspect of Fabry disease, treatment is at best only effective in Chronic Kidney Disease stage 1 or 2, before the deterioration of renal function or onset of overt proteinuria, as it does not reduce proteinuria per se. Once proteinuria ( $>1$  g/day) or CKD stage 3 (eGFR  $< 60$  mL/min/1.73m<sup>2</sup>) develops, there are no data supporting a potential protective effect of ERT. Taking this and the very high cost ( $> 200.000$  euro/year) into account, in our paper for ERBP, we recommend starting ERT in the context of a clinical trial, interventional or observational. As we need more knowledge, we conclude that it is necessary to enter all data in a central, not-industry dependent registry preferably at a European level.

Survival of Fabry patients on hemodialysis is poor, with a reported three-year survival of 60-63 %, which is lower than that of non-diabetic matched controls. There is no proof of an improved survival in renal replacement therapy patients on enzyme replacement therapy. Renal replacement therapy can serve as a bridge to transplantation, which has shown acceptable survival at 10 years compared to matched controls.

## **Perspectives**

Cardiovascular involvement contributes substantially to disease-related morbidity and mortality in Fabry disease [5]. Various cardiac symptoms including dyspnea, chest pain, palpitations and syncope are reported appearing in 60% of Fabry patients [6]. Pathology studies have shown that next to myocardial hypertrophy, fibrosis and scarring of the left ventricular wall is important [7]. Fifty percent of male Fabry patients had hyper-enhancement of the myocardium, suggestive for fibrosis. Additionally it is known that Gb-3 deposition can

be found in the specific cardiac conduction cells. Both predispose to ventricular arrhythmia [5]. The prevalence of symptomatic arrhythmia and the clinical importance of arrhythmia in patients with Fabry disease is largely unknown but may contribute to the occurrence of syncope (3,2% in [5]) and sudden cardiac death. Additionally it is well known that a substantial number of patients (especially males) develop severe bradycardia and chronotropic incompetence. Some of these patients could be treated with a permanent pacemaker/defibrillator. A significant number of Fabry patients have symptoms of congestive heart failure (11% in males in [5]). Some of these patients could be treated with resynchronization therapy using a biventricular pacemaker.

Indeed, in a screening study for Fabry disease in patients with left ventricular hypertrophy, 3 out of 4 patients detected had a permanent pacemaker [8]. In another screening study, 1 in 7 patients had a permanent pacemaker [9]. In a screening study for Fabry disease in kidney transplant recipients, 1 of 2 patients had a pacemaker for atrio-ventricular block [10].

In a study of 78 Fabry patients (43 men), 7 men (10.6%) had permanent pacemakers implanted for complete heart block ( $n = 1$ ), symptomatic bradycardia ( $n = 3$ ), LV outflow tract gradient reduction ( $n = 1$ ), and complete heart block after alcohol septal ablation ( $n = 1$ ). One received a biventricular device and defibrillator for heart failure and symptomatic ventricular hypertrophy [6]. In a large study, 6 in 124 (4.8%) untreated male Fabry patients had a permanent pacemaker [5]. In a study of 279 males with Fabry disease from Europe, Canada and the USA, 9 patients (3%) had a permanent pacemaker.

In this reasoning, the pacemaker population is a unique high-risk population, which has up to now not been studied for Fabry disease.

In a new study, we would like to screen systematically for Fabry disease in male patients with a permanent pacemaker or defibrillator in secondary and tertiary care hospitals in Belgium. A cohort of 500 men with a permanent pacemaker or defibrillator will be screened with a blood spot test for  $\alpha$ -Gal A deficiency. Inclusion criteria will be age  $\geq 30$  years and  $< 75$  years, as patients younger than 30 years with a permanent pacemaker are less likely to have Fabry disease. Most of them will have an atrio-ventricular block secondary to a congenital AV block, cardiac surgery for the correction of a congenital heart disease, or have a pacemaker/defibrillator for the treatment of long QT syndrome. While many pacemaker patients age 75 or older present with age-dependent fibrosis, patients in the fifth or sixth decade of their life are still likely to have Fabry disease, and more specifically a cardiac variant. Patients with proven prior myocardial infarction, defined with ECG, will be excluded from the screening, as heart disease secondary to ischemia is unlikely in Fabry disease. Patients will be asked to answer questions oriented to the signs and symptoms of Fabry disease. The questionnaire used in this study is based on the "FabryScan", a screening tool studied and validated for detection of Fabry disease in patients with pain [11]. Additional questions that can be helpful in detecting patients that have a higher pre-test probability for Fabry were added. Such a questionnaire could be an uninvative tool for screening for Fabry disease; comparable to the questionnaire we developed for boys and adolescents (Appendix).



As already mentioned, a second project concerns the *GLA* p.Ala143Thr (c. 427G>A). As we have doubts about the pathogenicity of this genetic alteration, we want to do further research on the impact on every organ system and the possible benefit of treatment and counselling. For this we plan to build a database on these patients. Next, with the work on *GLA* p.Ala143Thr, we plan to take part in the “Hamlet study”, designed by the researchers of the Academic Medical Centre (Amsterdam, The Netherlands) which was designed for “Valorisation of clinical and laboratory assessments for improved diagnosis of Fabry disease”.

Finally, this thesis can be considered as a part of the “Rare Diseases Project” at the Ghent University Hospital.

Rare diseases are life threatening or chronically debilitating diseases – mostly inherited – that affect so few people that special efforts are needed for diagnosis and treatment. In EU countries, any disease affecting fewer than 5 people in 10 000 is considered rare. It is estimated that today in the EU, 5-8000 distinct rare diseases affect 6-8% of the population or between 27 and 36 million people (For reference; [http://ec.europa.eu/health/rare\\_diseases/policy/index\\_en.htm](http://ec.europa.eu/health/rare_diseases/policy/index_en.htm)). Signs and symptoms of rare diseases can be aspecific but occur at an unusual young age or with an unusual severity. In case of Fabry disease, this is stroke, kidney failure and premature death. Fabry disease is inherited a special X linked manner, causing disease in all male and in most female patients. Some rare diseases can be treated if timely diagnosed, but this is the problem, as they are under-ascertained as a consequence of their rarity. As we have demonstrated in this thesis, there is a long period between emergence of the first symptoms and the appropriate diagnosis, which involves a risky delay as well as wrong diagnosis with inaccurate treatments. Referral to qualified specialists is often delayed, and even if not so, there is a lack of evidence-based therapy. As rare diseases are often systemic diseases, treatment in a multidisciplinary team is required, and many issues next to medical ones have to be covered, including psychological, dietary, social and financial.

Awareness of these aspects is important and has become an important subject of regulation at the level of the European Union and the Belgian government. The “Rare diseases project” has been set up at the Ghent University Hospital to facilitate this work. I hope in the future, I will be able to contribute to this exciting work on rare diseases.

## References

1. Mechtler, T. P. et al. Neonatal screening for lysosomal storage disorders: feasibility and incidence from a nationwide study in Austria. *The Lancet* 379, 335–341 (2012).
2. Chamoles, N. A., Blanco, M. & Gaggioli, D. Fabry disease: enzymatic diagnosis in dried blood spots on filter paper. *Clin. Chim. Acta* 308, 195–196 (2001).
3. Linthorst, G. E., Vedder, A. C., Aerts, J. M. F. G. & Hollak, C. E. M. Screening for Fabry disease using whole blood spots fails to identify one-third of female carriers. *Clinica Chimica Acta* 353, 201–203 (2005).
4. Terryn, W. et al. Prevalence of Fabry disease in a predominantly hypertensive population with left ventricular hypertrophy. *Int. J. Cardiol.* (2012).
5. Linhart, A. et al. Cardiac manifestations of Anderson-Fabry disease: results from the international Fabry outcome survey. *European Heart Journal* 28, 1228–1235 (2007).
6. Shah, J. S. et al. Prevalence and Clinical Significance of Cardiac Arrhythmia in Anderson-Fabry Disease. *Am. J. Cardiol.* 96, 842–846 (2005).
7. Sheppard, M. N. The heart in Fabry's disease. *Cardiovascular Pathology* 20, 8–14 (2011).
8. Hagege, A. A. et al. Screening patients with hypertrophic cardiomyopathy for Fabry disease using a filter-paper test: the FOCUS study. *Heart* 97, 131–136 (2010).
9. Elliott, P. et al. Prevalence of Anderson-Fabry disease in patients with hypertrophic cardiomyopathy: the European Anderson-Fabry Disease Survey. *Heart* 97, 1957–1960 (2011).
10. Kleinert, J. et al. Anderson-Fabry disease: a case-finding study among male kidney transplant recipients in Austria. *Transplant International* 22, 287–292 (2009).
11. Arning, K. et al. FabryScan: a screening tool for early detection of Fabry disease. *J. Neurol.* (2012).

# *Appendix*



## Population Screening

*Problems associated with the detection  
of atypical or unknown variants and  
presentation of a possible solution*

*The strategy used in Chapter 2 for case finding is the screening of high-risk groups. In order to detect patients at an early stage of the disease, the next step would be to screen in the population at a young age. This was performed in new-borns in Italy, Taiwan and Austria. It resulted in the detection of atypical Fabry disease with an attenuated phenotype, what brings along ethical problems, as many of these patients will remain completely asymptomatic for many decades. In order to overcome this problem, we designed a strategy to screen for symptomatic boys and adolescents.*

Screening of high-risk groups (hemodialysis patients, kidney transplant recipients, patients with left ventricular hypertrophy and cryptogenic stroke) have shown that Fabry disease is more frequent and has a much broader phenotypical spectrum than was previously assumed <sup>1</sup>. Later-onset cardiac and renal variants of Fabry disease have been detected mainly as a result of these studies <sup>2-4</sup>. These patients lack angiokeratoma, acroparesthesia, hypohidrosis and corneal opacities, which are classical manifestations of Fabry disease. Patients with the cardiac variant typically present in the 5<sup>th</sup>-8<sup>th</sup> decades of life with left ventricular hypertrophy, arrhythmia and/or heart failure. Patients with the renal variant develop proteinuria and later-onset renal failure, typically after the age of 50 <sup>3</sup>. Next, patients with cryptogenic stroke have been found to have Fabry disease, lacking classic early-onset symptoms and signs <sup>5</sup>. As a result of our screening studies, we learned that the *GLA* p.Ala143Thr mutation has a high prevalence in the Flemish population. This mutation had been associated with an attenuated phenotype presenting as a cardiac or renal variant or isolated stroke. We even found a much broader range of expression, where males as well as females can be completely asymptomatic or suffer from multi-organ involvement.

Screening of the general population for  $\alpha$ -Gal A deficiency with subsequent mutation analysis could be the next step to gain knowledge of the real prevalence of Fabry disease and to detect patients at an early stage of the disease, amenable for treatment. The first screening (Table A.1) of this kind was performed in Italy <sup>6</sup>, where 37104 male new-borns were screened for  $\alpha$ -Gal A deficiency. Twelve (1/3100) neonates had deficient  $\alpha$ -Gal A and a *GLA* mutation, but only one of these had a mutation causing the classic phenotype. Eleven neonates had mutations associated with later-onset phenotypes or a new sequence alteration with an unpredictable phenotype.

In the Taiwan Chinese population two large new-born screening studies were performed <sup>7,8</sup>. Low  $\alpha$ -Gal A activity and a *GLA* mutation was demonstrated in 45 <sup>7</sup> and 75 <sup>8</sup> neonates. This corresponds with a surprisingly high prevalence of up to 1/1250 in males. In a significant proportion of these new-borns, the IVS4 + 919G→A mutation was demonstrated. This is an intronic mutation associated with a cardiac variant <sup>9</sup>, which appears to have a low penetrance as only 1/3 of the grandfathers with this mutation had significant hypertrophic

**Table A.1.** Newborn screening for Fabry Disease.

Screened (n)	GLA mutations (n)	Classic FD (n)	Later onset or unknown phenotype (n)	Reference, region
37104	12 (1/3100 males)	1	11 (3/11 is A143T)	Spada <sup>6</sup> , Italy
110027	45 (1/1368 males)	1 (“mild classic”)	44 (1/44 is A143T)	Lin <sup>7</sup> , Taiwan
171977	75 (1/1250 males)	4 (predicted)	71	Hwu <sup>8</sup> , Taiwan
34736	9	0	9 (6/9 is A143T)	Mechtler <sup>10</sup> , Austria

cardiomyopathy.

A fourth screening study was recently performed in Austria <sup>10</sup>, screening 34736 of newborns of both genders for  $\alpha$ -Gal A activity. A low  $\alpha$ -Gal A activity and a *GLA* mutation were detected in 9 patients, yielding a frequency for Fabry disease of 1 per 3859 births. All babies had residual enzyme function, and none had a mutation associated with a classical phenotype.

We can conclude from these screening studies in neonates that mutations associated with Fabry disease are even more frequent than was assumed until recently and that it has a prevalence of up to 1 in 1250. The major part of these mutations are however not associated with the classical Fabry phenotype. The finding of a genetic predisposition for a possible late-onset disease where the treatment effectiveness is unclear can possibly have a negative impact on the proband. The long latency between diagnosis and disease possibly stigmatises and the affected persons might perceive their health as worse than it is. In these cases, it would be difficult to decide on enzyme replacement therapy, as the natural history of patients carrying atypical mutations is poorly characterized, effects of enzyme replacement therapy in mild cases have not been studied, and a lifelong treatment is a psychological burden for the patient and a financial one for both the individual and the society with on top of that uncertain results. As a consequence, in a paper with recommendations from the European Renal Association, we do not recommend screening for Fabry disease in the general population.

Within this reasoning, in order to detect patients with classic Fabry disease at a symptomatic but early stage of the disease, where enzyme replacement therapy could still have important benefits, we developed a strategy for the screening of symptomatic boys between the ages of 6 and 18 years using a questionnaire asking for classical Fabry symptoms (Table A.2). This questionnaire was developed using data from the Fabry Registry on the symptoms presenting in pediatric Fabry disease. Our hypothesis was that the negative predictive value for classical Fabry disease would be high, though this has not been validated. A case-control study in boys and adolescents aged 6-18 years would have to be performed first. In case of a “negative” questionnaire, classical Fabry disease could be excluded. If the answers to this questionnaire were scored “positive”, the next tier of this project would have been screening with dried blood spots for  $\alpha$ -Gal A deficiency, and if positive, in a third tier, mutation analy-

**Table A.2. Questionnaire.**

---

**Major questions**

---

I am having pain in the hands, feet, fingers, toes, eg tingling pain, burning sensation

I can do no great efforts or sports

I sweat very little

I endure no heat

I have little thickened red or purple spots on the skin

I have relatives with kidney disease, or who are in dialysis or who have a kidney transplant

My kidneys are not working normally

I have a decreased hearing

I often have tinnitus

There is protein in my urine

My ophthalmologist saw something unusual in my eyes

I have a family member with a heart problem at young age

I have a family member with stroke at a young age

---

**Minor questions**

---

I regularly have diarrhea and abdominal pains

I often feel bloated after my dinner

I have an irregular heartbeat or palpitations

I am abnormally tired

I sometimes have fever without obvious cause

I do not feel as healthy as my classmates

I often have headaches

---

sis. In our opinion, this way of screening could give a good estimate of the true prevalence of classic Fabry disease in the Flemish population, without the problematic detection of the much more frequent mutations associated with attenuated Fabry disease.

In **conclusion**, screening for Fabry disease in high-risk groups and in new-borns has widened the phenotypical spectrum and has proven that Fabry disease is more frequent than was previously assumed. The bulk of the patients with *GLA* mutations detected in the screening studies are however associated with attenuated phenotypes. The detection and treatment of these patients at an early age has no proven benefit and could even be harmful. As a result, newborn screening for Fabry disease cannot be recommended. The strategy we designed to detect young symptomatic boys and adolescents however could be useful.

## References

1. Linthorst, G. E. *et al.* Screening for Fabry disease in high-risk populations: a systematic review. *J. Med. Genet.* **47**, 217–222 (2010).
2. Nakao, S. *et al.* An Atypical Variant of Fabry's Disease in Men with Left Ventricular Hypertrophy. *N. Engl. J. Med.* **333**, 288–293 (1995).
3. Nakao, S. *et al.* Fabry disease: Detection of undiagnosed hemodialysis patients and identification of a 'renal variant' phenotype. *Kidney Int* **64**, 801–807 (2003).
4. Scheidt, W. V. *et al.* An Atypical Variant of Fabry's Disease with Manifestations Confined to the Myocardium. *N. Engl. J. Med.* **324**, 395–399 (1991).
5. Gregoire, S. M. *et al.* Posterior circulation strokes without systemic involvement as the presenting feature of Fabry disease. *Journal of Neurology, Neurosurgery & Psychiatry* **80**, 1414–1416 (2009).
6. Spada, M. *et al.* High Incidence of Later-Onset Fabry Disease Revealed by Newborn Screening\*. *The American Journal of Human Genetics* **79**, 31–40 (2006).
7. Lin, H. Y. *et al.* High Incidence of the Cardiac Variant of Fabry Disease Revealed by Newborn Screening in the Taiwan Chinese Population. *Circulation: Cardiovascular Genetics* **2**, 450–456 (2009).
8. Hwu, W.-L. *et al.* Newborn screening for Fabry disease in Taiwan reveals a high incidence of the later-onset *GLA* mutation c.936+919G>A (IVS4+919G>A). *Hum. Mutat.* **30**, 1397–1405 (2009).
9. Ishii, S., Nakao, S., Minamikawa-Tachino, R., Desnick, R. J. & Fan, J.-Q. Alternative Splicing in the  $\alpha$ -Galactosidase A Gene: Increased Exon Inclusion Results in the Fabry Cardiac Phenotype. *The American Journal of Human Genetics* **70**, 994–1002 (2002).
10. Mechtler, T. P. *et al.* Neonatal screening for lysosomal storage disorders: feasibility and incidence from a nationwide study in Austria. *The Lancet* **379**, 335–341 (2012).





# Summary



**F**abry disease is a rare disease caused by a mutation in the *GLA* gene, located on the X-chromosome, which encodes for alpha-Galactosidase A. This lysosomal enzyme plays a role in the degradation of certain glycosphingolipids, and deficiency leads to accumulation of globotriaosylceramide in the lysosomes of most cells of the body.

In its classical form, from the age of 3 to 10 years, symptoms arise such as acroparesthesias, hypohidrosis, heat intolerance and abdominal discomfort. More than half of the patients have angiokeratomas; small purplish elevations on the skin of the genitals, lumbosacral region and the thorax, which may increase with age. Proteinuria occurs in adulthood and frequently evolves to renal failure. There is a significantly increased incidence of ischemic stroke from the fourth and fifth decade and progressive left ventricular hypertrophy that can lead to rhythm and conduction disorders, heart failure and early death.

Fabry disease is very rare, with an estimated prevalence of 1/117,000. This prevalence is however an underestimation as the diagnosis is often missed. Rare diseases are not well known, and the symptoms are often aspecific. The signs and symptoms which have to be attributed to Fabry disease are often erroneously explained by the presence of more frequent co-morbidities such as arterial hypertension, vascular disease and diabetes mellitus which would explain the presence of left ventricular hypertrophy, stroke and proteinuria, preventing the clinician to think of rare metabolic disorders.

For these reasons, from the year 2000, researchers have been prompted to set up screening studies for Fabry disease in high-risk populations. The studies performed for this thesis have shown that the prevalence of Fabry disease is much higher than was previously assumed. In addition it became clear that the phenotype exhibits a very wide variation both in males and females. We have screened in haemodialysis patients, renal transplant recipients and patients with left ventricular hypertrophy. Among the 2135 patients screened, we found 9 cases, of which only 1 had been previously diagnosed. With these patients and with the identification of Fabry patients in the families of these index cases, we showed that the prevalence in Flan-

ders is much higher than assumed. A specific mutation, *GLA* p.Ala143Thr, proved to be very prevalent and occurred in 7 out of 9 index cases. This mutation was also quite prevalent in a population study in Austria. Notwithstanding this exonic mutation was associated with a decreased activity of alpha-Galactosidase A and in literature is considered to be pathogenic, we found conflicting data. Study of clinical and biopsy data from 41 adults with this mutation showed that there is no direct causal link between the morbidity attributed to Fabry disease on one hand and the mutation or enzyme deficiency on the other hand. The association of this mutation with renal failure or left ventricular hypertrophy could thus be based on a selection bias generated by screening of high-risk patients. We conclude from this that the diagnosis of Fabry disease requires more than the co-existence of a mutation, low enzyme activity and certain signs and symptoms and stresses the importance of biopsies. The prevalence of *GLA* p.Ala143Thr in our high-risk groups is, on the other hand, significantly higher than the prevalence in Austrian newborns, so a possible pathogenic role is certainly a possibility.

These findings obviously have an important impact on counselling and treatment of patients and their families. The guidelines regarding enzyme replacement therapy, which can be applied to patients with a classical phenotype, are not valid for these atypical cases.

Like in Flanders, screening studies throughout the world in high-risk populations and in newborns showed that the majority of the index cases have a genetic alteration in the *GLA* gene, which is associated with an unknown or attenuated phenotype. We do not know how to counsel and treat these patients. Because of this lack of knowledge we think that screening for *GLA* mutations in newborns is not indicated. Screening of high-risk groups however seems to be a good tool for case finding, as some kind of screening is probably the only way to find Fabry patients. In this context, we are planning a screening study in patients with a permanent pacemaker or internal defibrillator, an up to present unexplored high-risk population.

Screening symptomatic boys seems worthwhile, as this gives the opportunity to diagnose classical Fabry disease at an early stage of the disease. For this purpose, we developed a strategy, involving a questionnaire concerning classical Fabry signs and symptoms (e.g. acroparesthesias, hypohydrosis, heat intolerance, abdominal symptoms). If this questionnaire is scored as "positive", the diagnosis will be confirmed by measurement of alpha-Galactosidase A activity and *GLA* mutation analysis. First, this approach has the advantage that it aims at symptomatic boys with classical Fabry disease, where treatment and support is evidence-based. Secondly, this diagnostic approach using a questionnaire is also very low cost. However, this questionnaire should be further investigated for sensitivity, specificity and validity.

Most rare diseases are progressive and life threatening. Their low prevalence requires not only a special approach for diagnosis, but also special attention regarding treatment. The development of guidelines for nephrologists seemed a logical and important goal. A systematic literature review and consultation with European Fabry experts followed by peer review has resulted in guidelines for the diagnosis and treatment of Fabry disease in pa-

tients with Chronic Kidney Disease. This is published within the framework of the “European Renal Best Practice” (ERBP) Guidelines, an organ of the “European Renal Association” (ERA). We recommend screening for Fabry disease in males with chronic kidney disease with no clear aetiology under the age of 50. We do not recommend screening in older males since we focus on the classical forms of Fabry disease and mortality is very high in classical Fabry disease in males after the age of 50. In females, we propose no age limit, as the classical phenotype can become apparent at an older age. In males, the measurement of the activity of alpha-Galactosidase A is preferred, as this test is very sensitive, specific and inexpensive. In females, mutation analysis is necessary as there can be residual enzyme activity in a significant part of the patients. From a systematic literature research, we conclude that there is little evidence for enzyme replacement therapy for nephrological reasons, and if therapy is started, it must be done before significant proteinuria occurs and before creatinine clearance falls below 60 ml/min/1.73 m<sup>2</sup>. All patient data on enzyme replacement therapy should be collected in a central, possibly European, database, as the evidence for this expensive treatment has to further studied.

**I**n conclusion, we argue that the prevalence of both the classical and attenuated forms of Fabry disease is underestimated and a special approach for the diagnosis including the screening in high-risk populations is necessary. The attenuated forms, however, have a very broad phenotype and no clear genotype / phenotype correlation. This applies in particular to the *GLA* p.Ala143Thr mutation, which is very prevalent in Flanders and has important implications for the treatment and counselling of these patients. Given the fact that there is little evidence for a general beneficial effect of enzyme replacement therapy, especially in atypical disease, further study is warranted.



# Samenvatting

**D**e ziekte van Fabry is een zeldzame ziekte veroorzaakt door een mutatie in het *GLA* gen, gelegen op het X-chromosoom, dat codeert voor alfa-Galactosidase A. Dit lysosomaal enzyme speelt een rol in de degradatie van bepaalde glycospingolipiden, en deficiëntie leidt tot stapeling van onder andere globotriaosylceramide in de lysosomen van de meeste cellen in het lichaam.

In de klassieke vorm ontstaan reeds vanaf de leeftijd van 3 tot 10 jaar symptomen zoals acroparesthesieën, hypohidrosis, warmte-intolerantie en abdominale klachten. Meer dan de helft van de patiënten heeft angiokeratomen, kleine paarse verhevenheden op de huid van de genitalia, lumbosacrale regio en de thorax, die met de leeftijd kunnen toenemen. Op volwassen leeftijd ontstaat proteïnurie, wat frequent evolueert naar nierfalen. Er is een sterk toegenomen incidentie van ischemische cerebrovasculaire accidenten vanaf de vierde en vijfde decade en progressieve linker ventrikel hypertrofie die in een eindstadium kan leiden tot ritme- en geleidingsstoornissen, hartfalen en vroege dood.

De ziekte van Fabry is erg zeldzaam, met een geschatte prevalentie van 1/117000. De prevalentie wordt echter onderschat door het feit dat de diagnose dikwijls wordt gemist. Zeldzame ziektes zijn op zich slecht bekend, en de symptomen zijn dikwijls niet specifiek, zodat klinici de diagnose niet makkelijk stellen. Daarbij kunnen de aan de ziekte van Fabry toe te schrijven tekenen en symptomen dikwijls verkeerdelijk worden verklaard door de aanwezigheid van veel frequentere co-morbiditeit zoals arteriële hypertensie, vaatlijden en diabetes mellitus die dan respectievelijk linker ventrikelhypertrofie, CVA en proteïnurie zouden verklaren, zodat men niet denkt aan zeldzame metabole aandoeningen.

Vanaf het jaar 2000 heeft dit onderzoekers gedreven om screeningsstudies op te zetten naar de ziekte van Fabry in populaties met een verhoogd risico. Deze studies, waar het onderzoek uitgevoerd in het kader van deze thesis toe behoort, hebben aangetoond dat de prevalentie van de ziekte van Fabry veel hoger is dan vroeger werd aangenomen. Daarnaast, en dit is minstens even belangrijk, werd duidelijk dat het fenotype een zeer brede variatie vertoont, zowel bij mannen als bij vrouwen.

Wij hebben gescreend bij hemodialysepatiënten, niertransplantpatiënten, en pa-

tiënten met linker ventrikel hypertrofie. Onder de 2135 gescreende patiënten vonden wij 9 gevallen, waarvan slechts 1 voordien reeds was gediagnosticeerd. Mede door de identificatie van Fabry patiënten in de families van deze index-casussen werd duidelijk dat de prevalentie in Vlaanderen veel hoger was dan vroeger werd aangenomen. Eén bepaalde mutatie, *GLA* p.Ala143Thr, bleek erg prevalent te zijn en kwam voor bij 7 van de 9 indexgevallen. Deze mutatie bleek ook vrij prevalent in een bevolkingsstudie in Oostenrijk. Niettegenstaande deze exonische mutatie geassocieerd is met een verminderde activiteit van alfa-Galactosidase A en in de literatuur beschouwd wordt als "pathogeen" kregen we twijfels over zijn pathogeniciteit. Studie van klinische en biopsiegegevens van 41 volwassenen met deze mutatie toonde aan dat er geen direct oorzakelijk verband bestaat tussen de aan de ziekte van Fabry geattribueerde morbiditeit enerzijds en de mutatie/enzymdeficiëntie. De associatie van deze mutatie met nierfalen of linker ventrikelhypertrofie zou aldus kunnen berusten op een selectiebias gegenereerd door screening van hoog-risicopatiënten. We besluiten hieruit dat het stellen van de diagnose van de ziekte van Fabry meer vereist dan de aanwezigheid van een mutatie, een lage enzymactiviteit en bepaalde tekenen en symptomen, en benadrukt het belang van biopsies. De prevalentie van *GLA* p.Ala143Thr in onze hoog-risicogroepen is daartegen wel duidelijk hoger dan de prevalentie bij Oostenrijkse pasgeborenen, zodat een eventueel pathogene rol zeker nog verder onderzoek verdient. Deze bevindingen hebben uiteraard ook een belangrijke impact op de begeleiding en behandeling van deze patiënten en hun familie. De richtlijnen voor enzymsubstitutie-therapie die gelden voor patiënten met een klassiek fenotype zijn in dit geval niet geldig.

Ook in screeningsstudies uitgevoerd buiten Vlaanderen bij andere risicogroepen en bij pasgeboren bleek het grootste deel van de patiënten een genetische alteratie in het *GLA* gen te hebben dat ofwel een nog onbekend effect heeft op het fenotype, ofwel gecorrigeerd is met een geattenuëerd fenotype. Ook daar is het nog onduidelijk hoe we deze patiënten zullen moeten begeleiden. Omwille van dit gebrek aan kennis is het voor ons dan ook alvast duidelijk dat screenen naar *GLA* mutaties bij pasgeborenen niet aangewezen is. Het screenen van de reeds gekende hoog risicogroepen lijkt echter wel een goed middel voor case-finding gezien het feit dat één of andere vorm van screening vermoedelijk de enige methode is om Fabry patiënten te vinden. In dit kader plannen we ook een screeningsstudie bij patiënten met een permanente pacemaker of interne defibrillator, een tot heden nog niet onderzochte hoog risicopopulatie.

Screening naar de klassieke vorm van de ziekte van Fabry bij symptomatische jongens lijkt ons ook zinvol gezien we op die manier klassieke ziekte van Fabry in een vroeg stadium zouden detecteren. Hiervoor hebben we een strategie ontwikkeld, waarbij eerst een vragenlijst wordt afgenomen naar klassieke symptomen van de ziekte van Fabry (o.a. acroparesthesiën, hypohydrosis, warmte-intolerantie, abdominale symptomen). Indien deze vragenlijst "positief" wordt gescoord, wordt de diagnose bevestigd door meting van alfa-Galactosidase A activiteit en mutatie-analyse. Deze aanpak heeft als voordeel dat men zich met een vragenlijst richt op symptomatische jongens, waar de behandeling en begeleiding evident en nuttig is. Anderzijds is diagnostische aanpak waar men eerst screent met een

vragenlijst ook zeer goedkoop. Wel dient deze vragenlijst nog verder onderzocht worden op gevoeligheid, specificiteit en validiteit.

De meeste zeldzame ziekten zijn progressief en levensbedreigend. Hun lage prevalentie eist niet enkel een speciale aanpak om tot de diagnose te komen, maar er is ook speciale aandacht nodig met betrekking tot hun behandeling. Hiervoor richtlijnen opstellen was dan ook een logisch en belangrijk doel. Een systematische literatuurstudie en overleg met Europese Fabry experts gevolgd door peer review heeft geresulteerd in richtlijnen voor de diagnose en behandeling van de ziekte van Fabry bij patiënten met chronisch nierlijden. Dit wordt gepubliceerd binnen het kader van de "European Renal Best Practice" (ERBP) Guidelines, een orgaan van de "European Renal Association". We raden aan om te screenen naar de ziekte van Fabry bij mannen met chronisch nierlijden zonder duidelijke etiologie onder de leeftijd van 50 jaar. We raden niet aan te screenen bij ouderen gezien we ons richten op de klassieke vormen de mortaliteit bij mannelijke patiënten boven de leeftijd van 50 jaar zeer hoog is. Bij vrouwen houden we geen leeftijdslimiet, gezien het fenotype bij vrouwen extreem variabel kan zijn, en een mutatie die geassocieerd is met een klassiek fenotype zich ook op hogere leeftijd kan uiten. Bij mannen is de meting van de activiteit van alfa-Galactosidase A te verkiezen, gezien deze test zeer gevoelig en goedkoop is. Bij vrouwen is mutatie-analyse noodzakelijk. We besluiten dat er weinig evidentie bestaat voor enzymsubstitutie therapie omwille van nefrologische redenen, en indien therapie gestart wordt, moet dit gebeuren vooraleer er belangrijke proteïnurie ontstaat en vooraleer de creatinineklaring zakt onder 60 ml/min/1.73 m<sup>2</sup>. Alle patiëntengegevens betreffende enzymsubstitutie therapie zouden in een centrale, eventueel Europese, databank moeten verzameld worden om de evidentie voor deze dure behandeling te onderzoeken.

**T**ot besluit stellen we dat de prevalentie van zowel de klassieke als geattenueerde vormen van de ziekte van Fabry onderschat wordt en een speciale benadering voor de diagnostiek onder andere via screening in hoog-risicopopulaties noodzakelijk is. De geattenueerde vormen hebben echter een zeer breed fenotype en geen duidelijke genotype/fenotype correlatie. Dit geldt in het bijzonder voor de *GLA* p.Ala143Thr mutatie die in Vlaanderen erg prevalent is. Dit heeft belangrijke consequenties voor de behandeling en begeleiding van deze patiënten. Gezien er ook voor de klassieke vormen van de ziekte van Fabry onvoldoende evidentie is voor een te veralgemenen gunstig effect van de (extreem dure) enzymsubstitutie therapie is verder onderzoek van groot belang.





# Résumé



La maladie de Fabry est une maladie rare secondaire à une mutation dans le gène *GLA*, liée au chromosome X, qui code pour alfa-Galactosidase A. Cet enzyme lysosomal joue un rôle dans la dégradation de certaines glycosphingolipides, et la carence entraîne une accumulation de globotriaosylcéramide, notamment dans les lysosomes de la plupart des cellules de l'organisme.

Dans la forme classique, dès l'âge de 3 à 10 années, il y a des symptômes tels que des acroparesthésies, hypohidrose, intolérance à la chaleur, et des troubles abdominaux. Plus de la moitié des patients ont des angiokératomes, qui sont de petites élévations mauves sur la peau des organes génitaux, de la région lombo-sacrée et le thorax, ce qui peut augmenter avec l'âge. Une protéinurie survient à l'âge adulte, qui évolue fréquemment vers l'insuffisance rénale. Il y a une incidence significativement accrue d'accidents vasculaires cérébraux ischémiques dès la quatrième et cinquième décennie de la vie et une hypertrophie ventriculaire gauche progressive qui, au stade terminal, peut conduire à des troubles de la conduction et du rythme, à l'insuffisance cardiaque et à une mort précoce.

La maladie de Fabry est très rare, avec une prévalence estimée à 1/117000. La prévalence est sous-estimée, cependant, par le fait que le diagnostic est souvent méconnu. Les maladies rares sont assez mal connues, et les symptômes sont souvent aspécifiques, de sorte qu'il n'est pas facile pour les cliniciens de faire le diagnostic. Les signes et symptômes de la maladie de Fabry peuvent souvent être expliqués par la présence d'une comorbidité beaucoup plus prévalente telle que l'hypertension artérielle, les maladies vasculaires et le diabète sucré. De cette manière, l'hypertrophie ventriculaire gauche, l'accident vasculaire cérébral et la protéinurie sont «expliqués» et le clinicien ne pense point aux rares troubles métaboliques.

A cause de ces raisons, à partir de 2000, les chercheurs ont abordés des études de dépistage de la maladie de Fabry chez les populations à haut risque. Ces études, dont la recherche effectuée dans le cadre de cette thèse fait partie, ont montré que la prévalence de la maladie de Fabry est beaucoup plus élevée qu'on ne le pensait. En outre, et tout aussi important, il est devenu clair que le phénotype présente une

très grande variation dans les hommes et les femmes.

Nous avons fait des études de dépistage chez les patients hémodialysés, chez les patients avec une transplantation rénale et chez les patients présentant une hypertrophie ventriculaire gauche. Parmi les 2135 patients dépistés, nous avons trouvé 9 cas, dont seulement 1 avait déjà été diagnostiqué auparavant. En raison de l'identification des patients Fabry dans les familles de ces cas index, on a montré que la prévalence en Flandre était beaucoup plus élevée que prévue. Une mutation spécifique, *GLA* p.Ala143Thr, s'est avérée très répandue et s'est produite dans 7 des 9 cas index. Cette mutation était également assez répandue dans une étude de population chez des nouveaux nés en Autriche. Malgré que cette mutation exonique soit associée à une diminution de l'activité de l'alpha-Galactosidase A et est considéré dans la littérature comme «pathogénique» on avait des doutes sur sa pathogénicité. L'étude des données cliniques et anatomopathologiques de 41 adultes atteints de cette mutation a montré qu'il n'existe pas de lien de causalité direct entre la morbidité qui est attribuée à la maladie de Fabry d'une part, et la mutation ou la carence d'enzyme d'autre part. L'association de cette mutation avec une insuffisance rénale ou une hypertrophie ventriculaire gauche pourrait donc être fondée sur un biais de sélection générée par le dépistage des patients à haut risque. Nous en concluons que le diagnostic de la maladie de Fabry exige plus que la présence d'une mutation, d'une activité enzymatique diminuée et certains signes et symptômes, et nous incite de faire des biopsies. Ces résultats ont évidemment un impact important sur la prise en charge de ces patients et de leurs familles. Les recommandations sur le traitement des patients avec la maladie de Fabry «classique» ne sont pas valides dans les cas «atypiques». Néanmoins, la prévalence de la *GLA* p.Ala143Thr dans nos groupes à haut risque est clairement supérieure à la prévalence chez les nouveaux nés autrichiens, donc un rôle pathogène est possible et mérite certainement une enquête plus approfondie.

Comme en Flandre, les études de dépistage menées partout au monde dans les groupes à haut risque et dans les nouveau-nés ont montrés que la majorité des patients ont une altération génétique dans le gène de *GLA* qui, ou bien est encore inconnue, ou est corrélée à un phénotype atténué. En manque de connaissance, la prise en charge de ces patients est très difficile. En raison de ce manque de connaissance, le dépistage de mutations *GLA* des nouveau-nés est dans notre opinion inapproprié. En revanche, le dépistage des groupes à haut risque semble être un outil indispensable pour le diagnostic. Dans ce contexte, nous envisageons une étude de dépistage dans une population jusqu'à présent inexplorée, à savoir les patients ayant un stimulateur cardiaque ou un défibrillateur interne permanent.

Le dépistage de la forme classique de la maladie de Fabry chez les garçons symptomatiques nous semble intéressant. Pour cela, nous avons développé une stratégie, impliquant un questionnaire sur les symptômes classiques de la maladie de Fabry (par exemple acroparesthésies, hypohydrosis, intolérance à la chaleur, symptômes abdominaux). Si ce questionnaire est marqué comme «positif», le diagnostic est confirmé par la mesure de l'activité de l'alpha-Galactosidase A et l'analyse mutationnelle. Cette approche a l'avantage de se rendre aux garçons symptomatiques, où le traitement est évident. Deuxièmement, l'approche dia-

agnostique avec un questionnaire est très peu coûteuse. Toutefois, ce questionnaire devrait être étudié pour sa sensibilité, spécificité et validité.

La plupart des maladies rares sont progressifs et dangereux. Leur prévalence est très faible, et il faut non seulement une approche spécifique pour le diagnostic, mais aussi une attention particulière en ce qui concerne leur traitement. La conception de lignes directrices pour néphrologues était pour nous un objectif logique et importante. Une revue systématique de la littérature et la consultation avec des experts européens de Fabry a donné lieu à des lignes directrices pour le diagnostic et le traitement de la maladie de Fabry chez les patients atteints de néphropathie chronique. Il sera publié dans le cadre de la «European Renal Best Practice (ERBP) Guidelines», un organe de l'«European Renal Association». Nous recommandons le dépistage de la maladie de Fabry chez les hommes atteints de maladie rénale chronique sans étiologie claire sous l'âge de 50 ans. Nous ne recommandons pas le dépistage chez les mâles plus âgés puisque nous nous concentrons sur les formes classiques de la maladie de Fabry. Chez les femmes, nous ne retenons aucune limite d'âge, étant donné le fait que le phénotype chez les femmes peut être extrêmement variable, et une mutation associée à un phénotype classique peut s'exprimer dans la vieillesse. Chez les hommes, la mesure de l'activité de l'alpha-Galactosidase A est à privilégier, compte tenu que ce test est très sensible et peu coûteux. Chez les femmes, l'analyse de mutation *GLA* est nécessaire. Nous concluons qu'il existe peu de preuves pour l'enzymothérapie substitutive pour des raisons néphrologiques, et si le traitement est commencé, il faut le faire avant qu'il y ait une protéinurie importante et avant que la clairance de la créatinine soit inférieure à 60 mL/min/1.73 m<sup>2</sup>. Toutes les données sur l'enzymothérapie substitutive devraient être collectionnées dans un endroit central, peut-être européen, enfin d'apporter des preuves scientifiques pour ce traitement cher.

**N**ous concluons que la prévalence des formes classiques et atténués de la maladie de Fabry est sous-estimée et une approche spécifique pour le diagnostic, y compris par le dépistage dans les populations à haut risque, est nécessaire. Les formes atténuées cependant, ont un phénotype très variable et il n'y a pas une simple corrélation génotype / phénotype. Ceci s'applique en particulier à la mutation *GLA* p.Ala143Thr qui est très répandue en Flandre. Ceci a des implications importantes pour la prise en charge de ces patients. Etant donné que la preuve pour un effet bénéfique généralisable de l'enzymothérapie substitutive (qui est très chère) est insuffisante, la recherche restera de grande importance.



# Curriculum Vitae

Wim Terryn

Regionaal Hospital Jan Yperman, Ypres, Belgium  
department of nephrology, general internal medicine and infectiology  
+3257/ 357181 (phone) +3257468338 (fax)  
wim.terrbyn@iCloud.com

## **Education**

- 1973-1985 Latin-Sciences, Klein Seminarie, Roeselare, Belgium.
- 1985-1990 Master in Psychological Sciences, Ghent University, Belgium.  
Great distinction.
- 1990-1997 Medical Doctor, Ghent University, Belgium. Great distinction.
- 1999 Certificate for Acute Medicine.
- 2002 Board certificate of Internal Medicine
- 2003 Board certificate of Nephrology
- 2003-2004 department of Nephrology, Ghent University Hospital, Belgium  
(Adjunct-Kliniekhoofd)
- 2004-present - Regional Hospital Ypres, Ieper, Belgium  
department of Nephrology, General Internal Medicine and Infectiology  
president of the Antibiotic Committee  
director of the Travel Clinic (WHO certificate for Yellow Fever Vaccination)  
- Ghent University Hospital  
consultant at the department of Sonography
- 2010- present PhD training program of Doctoral School of Life Sciences and Medicine,  
Ghent University, Belgium.  
PhD thesis: "Screening for Fabry disease: indications, methods and implications."
- 2011 NIH Clinical Research Training course, GCP exam.

## **Affiliations**

Member of BTS (Belgian Transplantation Society)

Member of ESOT (European Society of Organ Transplantation)

## **Current projects**

### *Interventional clinical study*

Individually Adapted Immunosuppression in de Novo Renal Transplantation Based on Immune Function Monitoring: a Prospective Randomized Study (CD4-01) NCT00895206.

Department of Internal Medicine, division of Nephrology (Prof. dr. Raymond Vanholder)

### *Clinical working project*

"The rare disease project",

Department of General Internal medicine, Infectiology and Psychosomatic Diseases (prof. dr. Bruce Poppe, prof. dr. Dirk Vogelaers), Ghent University Hospital

### *Clinical research project*

"Study to verify the frequency of Fabry disease in pacemaker patients, a new and unique population."

## **Publications**

Terryn W, Van Caesbroeck D, "Magnesium and Phosphorus", *Lancet*, 352, (9138), 31 October 1998, 1475-1475 (Letter to the editor).

Terryn W, Van Caesbroeck D, "Refeeding syndrome met hypofosfatemie en hemolytische anemie", *Tijdschrift voor Geneeskunde*, 56, nr 13, 2000.

Randon C, Deroose J, Vermassen F, Terryn W, Peeters P, Giri M. "Pancreastransplantatie: state of the art", *Tijdschrift voor Geneeskunde*, 63, nr 6, 2007.

De Schoenmakere G, Poppe B, Wuyts B, Claes K, Cassiman D, Maes B, Verbeelen D, Vanholder R, Kuypers DR, Lameire N, De Paepe A, Terryn W. Two-tier approach for the detection of alpha-galactosidase A deficiency in kidney transplant recipients. *Nephrol Dial Transplant*. 2008 Dec;23(12):4044-8. Epub 2008 Jul 2.

Terryn W, Poppe B, Wuyts B, Claes K, Maes B, Verbeelen D, Vanholder R, De Boeck K, Lameire N, De Paepe A, De Schoenmakere G. Two-tier approach for the detection of alpha-galactosidase A deficiency in a predominantly female haemodialysis population. *Nephrol Dial Transplant*. 2008 Jan;23(1):294-300. Epub 2007 Sep 5.

Terryn W, Benoit D, Van Loo A, Peeters P, Schepkens H, Cokelaere K, Vanholder R. Goodpasture's syndrome associated with autoimmune thrombotic thrombocytopenic purpura an unusual case. *Nephrol Dial Transplant*. 2007 Dec;22(12):3672-3. Epub 2007 Jul 19.

De Schoenmakere G, De Waele J, Terryn W, Deweweire M, Verstraete A, Hoste E, Rottey S, Lameire N, Colardyn F. Phenytoin intoxication in critically ill patients. *Am J Kidney Dis*. 2005 Jan;45(1):189-92.

- Peeters P, Terryn W, Vanholder R, Lameire N. Delayed graft function in renal transplantation. *Curr Opin Crit Care*. 2004 Dec;10(6):489-98. Review.
- Vanbelleghem H, Terryn W, Van Leuven L, Van Caesbroeck D, Demetter P, Lameire N. A dramatic case of calci-phylaxis 20 years after kidney transplantation. *Nephrol Dial Transplant*. 2004 Dec;19(12):3183-5.
- Terryn W, Deschoenmakere G, De Keyser J, Meersseman W, Van Biesen W, Wuyts B, Hemelsoet D, Pascale H, De Backer J, De Paepe A, Poppe B, Vanholder R. Prevalence of Fabry disease in a predominantly hypertensive population with left ventricular hypertrophy. *Int J Cardiol*. 2012 Jul 15. [Epub ahead of print]
- Terryn W, Vanholder R, Hemelsoet D, et al. Questioning the Pathogenic Role of the *GLA* p.Ala143Thr "Mutation" in Fabry Disease: Implications for Screening Studies and ERT. *JIMD Reports*. Volume 8, 2013, pp 101-108.
- Terryn W, Cochat P, Froissart R, Ortiz A, Pirson Y, Poppe B, Serra A, Van Biesen W, Vanholder R, Wanner C. Fabry nephropathy: indications for screening and guidance for diagnosis and treatment by the European Renal Best Practice. *Nephrol Dial Transplant*. 2012 Dec 12. [Epub ahead of print]
- Laute M, Vanholder R, Voet D, Peeters P, Cokelaere K, Deloose S, Terryn W. Safety and sample adequacy of renal transplant surveillance biopsies. *Acta Clinica Belgica* (accepted)

### **Presentations at international conferences**

- 19/11/2004: 2nd Benelux symposium on lysosomal storage diseases, Waalwijk, Nederland.  
Session; "Improving early diagnosis of LSD patients",  
Chairman: Dr. B.J.H.M. Poorthuis, LUMC Leiden.  
*Presentation*; "Screening of clinical groups." dr. W. Terryn
- 11/5/2012: Fabry Masterclass IV: "Fabry disease: past, present and future", Berlin, Germany.  
*Presentation*; "Renal Outcomes", dr. W. Terryn

### **Courses**

- 1998 Dialysis Academy (prof Ritz, prof Drüeke, prof Lameire) ,Ghent, Belgium
- 2000 Dialysis Academy, Heidelberg, Germany
- 2002 PD (Peritoneal Dialysis) Academy (prof. dr. Krediet), Amsterdam, The Netherlands
- 2002 Hesperis-ESOT (European Society of Transplantation) course for transplantation, Cambridge, England
- 2003 Hesperis-ESOT course for transplantation, Paris, France.
- 2008 - 2009 Advanced nephrology course, part 1 + 2, the renal association, London, UK.
- 2009 - 2010 Instituut voor permanente vorming in de Wetenschappen IPVW:  
cursus statistiek "Basics of Statistical Inference" en "Analysis of Variance",  
Ghent University, Belgium.





# Woorden van dank



*De tijd dat wetenschap een eenzame en soms wereldvreemde bezigheid was, ligt gelukkig ver achter ons. Nieuwe ontwikkelingen en kennis ontstaan via uitwisseling en samenwerking. Ook voorliggend werk is een werk van vele mensen. Ik heb de kans gekregen om dit werk uit te bouwen dankzij vele ontmoetingen met mijn promotoren, met collega's en met mensen uit mijn directe omgeving. Mijn dank gaat naar elk van hen.*

*Bedankt prof. Raymond Vanholder, mijn promotor, voor de kritische evaluatie en de snelle antwoorden op mijn talrijke mails. De tactvolle en scherpzinnige opmerkingen hebben mij veel geleerd, ze hebben deze thesis mee vorm gegeven.*

*Twee bijzondere vrienden stonden mee aan de wieg van dit doctoraat: dr. Gert Deschoenmakere en prof. Bruce Poppe hebben me van in het begin enthousiast gesteund. Gert hielp de screeningsstudies op gang, en toonde mij de weg om de opportuniteiten te grijpen. Het is bovendien een grote eer dat mijn vriend Bruce, naar wie ik heel erg opkijk, mijn co-promotor wilde zijn.*

*Prof. Van Biesen kreeg in een handomdraai een team Europese Fabry-experten rond de tafel om te discussiëren. Boeiend en heel leerrijk.*

*In het concrete onderzoek waren vele mede-onderzoekers en ondersteunende collega's betrokken. In het bijzonder denk ik hierbij aan dr. Dimitri Hemelsoet en dr. Birgitte Wuyts, maar ik mag prof. Kathleen Claes, dr. Maria Alvarez, dr. Katrien Van Elk, Filip Labeeuw, Katrien Van Geyt en ook de vele artsen die de moeite deden om patiënten te includeren voor de screeningsstudies niet vergeten.*

*In veel klinisch onderzoek is de inzet van de farmaceutische economie onontbeerlijk. Dit onderzoek is mee mogelijk gemaakt door de firma's Genzyme en Shire. De vriendelijkheid, het enthousiasme en de ethische houding van hun medewerkers*

*hebben mij gesteund in dit werk.*

*De positieve belangstelling en steun van de collega's van het Jan Yperman Ziekenhuis en het UZ Gent hebben mij gesterkt in dit onderzoek.*

*Wetenschap heeft ook te maken met het dagelijks leven. Enkele mensen uit mijn dagelijkse omgeving hebben mee gebouwd, gesteund, gelouterd soms ook. Mijn familie, in het bijzonder Annik en Luc, heeft me veel geleerd over studeren op zich, over na-denken en stilstaan, over het hoe en het waarom misschien, maar vooral over het leven zelf. Achter al mijn projecten en gedrevenheid schuilt één grote kracht die ik krijg van mijn vader, een tachtiger met een jong hart.*

*Ten slotte dank ik mijn vrouw Mieke en onze fantastische dochters Lou, Aglaja en Rilke voor hun warme liefde, hun dagelijkse steun en hun volgehouden geduld. Zonder hen zou dit werk nooit geschreven zijn.*

*Bedankt!*

*Wim Terry*

*Beselare, maart 2013*