



biblio.ugent.be

The UGent Institutional Repository is the electronic archiving and dissemination platform for all UGent research publications. Ghent University has implemented a mandate stipulating that all academic publications of UGent researchers should be deposited and archived in this repository. Except for items where current copyright restrictions apply, these papers are available in Open Access.

This item is the archived peer-reviewed author-version of:
Title

Authors: Liliane Haegeman

In: **Studia Linguistica**

Publisher: **Wiley**

pages **68:1: 116-139.**

WEST FLEMISH VERB-BASED DISCOURSE MARKERS AND THE ARTICULATION OF THE SPEECH ACT LAYER*

Liliane Haegeman, Ghent University

Abstract. This paper focuses on the West Flemish discourse markers located at the edge of the clause. After a brief survey of the distribution of discourse markers in WF, the paper proposes a syntactic analysis of the discourse markers *né* and *wè*. Based on the distribution of these discourse markers, of vocatives and of dislocated DPs, an articulated speech act layer is elaborated which corroborates the proposals in Hill (2007b). It is postulated that there is a syntactic relation between particles used as discourse markers and vocatives. The paper offers further support for the grammaticalization of pragmatic features at the interface between syntax and discourse and for the hypothesis that the relevant computation at the interface is of the same nature as that in Narrow Syntax.

1. Introduction

The empirical focus of this paper is a set of particles that appear on the clausal edge and that are used as discourse markers (DM) (cf. Fischer 2006) in West Flemish (WF), a dialect of Dutch, and also in the Flemish *tussentaal* (“between-language”). Apart from Haegeman (1984, 1993), which discusses the DM *da*, the empirical data presented here have, to the best of my knowledge, not been discussed systematically in the generative

* This paper is partly based on my talk presented at the *Workshop on Particles* held at the University of Cambridge, October 30-31, 2008. I thank the organizers, Theresa Biberauer and Glenda Newton, for their kind invitation and the audience of the workshop, the audience of my talk at the University of York Linguistics department in April 2009, two independent reviewers for *Studia Linguistica* and my PhD students, Lieven Danckaert, Karen Declercq, Will Harwood, Rachel Nye and Amélie Rocquet, for feedback. Special thanks to Lobke Aelbrecht and to Lieven Danckaert for comments on a first version of the paper. Thanks to Bernard Declercq, Virginia Hill and Terje Lohndal for very insightful discussion and for judgements thanks to Geert Bonamie, Bernard Declercq, and Katrien

literature. The goal of this paper is twofold. The first part presents a brief overview of the distribution of WF sentence-initial and sentence-final DMs. The second part of the paper analyzes the distribution of two specific DMs: *nè(m)* ('so there', 'take that') and *wè* ('you know'), and their relation to vocatives. On the basis of the distribution of these two particles a hypothesis is elaborated concerning the syntactic representation of speech acts. The conclusions reached in the current paper are very much in line with work by Hill (2007b).

The paper is organised as follows: Section 2 offers a survey of a number of DMs surfacing at the right or left edge of the WF utterance. I discuss their etymology, interpretation and distribution relative to the utterance and relative to each other. In section 3, I outline the core data. Section 4 provides a first analysis based on proposals in the literature. Section 5 relates the proposed analysis to work by Hill (2007b). Section 6 summarises the paper and discusses issues for future research.

2. West Flemish particles: a survey

2.1. Position

Like Dutch particles (van der Wouden 2002, 2009, Schelfhout, Coppen, Oostdijk & van der Silk 2005), WF particles are mainly found in two areas of the clause: (i) in the middle field, i.e. IP-internally, and (ii) on the edge of the clause, either preceding the clause or following it, i.e. the DMs. I do not discuss WF middle field particles here: they seem at first sight to have the same syntactic and semantic properties as the better studied Dutch and German modal particles (cf. Schelfhout *et al* 2005, Coniglio 2007, del Gobbo & Poletto 2008, etc.). I focus exclusively on the WF DMs at the clausal edge, which typically encode the speaker's attitude with respect to the (contents of) the speech act and/or with respect to the addressee. As will be shown in section 2, most of these DMs derive from verbs (see Cardinaletti 2011 for a brief discussion of verb-based particles in Italian). All the DMs discussed are 'optional' in that an utterance remains grammatical if a DM is removed, but deletion of the DM results in a change in interpretation. As the final DM forms an intonational unit with the preceding clause (see

van Kirsner & van Heuven 1996 for intonation patterns), removing the DM requires adjusting the intonational contour of the clause.

(1) offers some examples. Because it is difficult to translate DMs, I retain the original form of the DM in the glosses. The idiomatic translation tries to convey the discourse effect achieved by the DM. DMs may be initial or final (see also Table 1). Exclusively initial DMs are *mo(r)*, *allè*, *gow*, *soei* (1a,b); exclusively final DMs are *da* (see Haegeman 1984, 1993), while *wè/wei*, *zulle* (1c,d); ¹ *zè* and *né* may precede or follow the clause.

(1) a. Mo/Allè /gow m' een toch al een medalie.

Mo/Allè /gow we have PART already a medal

‘Come one, we already have a medal.’

b. Soei, je mist were!

soei, he misses again

‘Look, he misses again.’

c. M' een al een medalie wè/zulle.

we have already a medal *we/zulle*

‘We already have a medal, you know.’

d. Zè/né, m' een al een medalie.

zè/né, we have already a medal

‘Look, we already have a medal.’

e. M' een al een medalie zè/né.

we have already a medal *zè/nè*

‘We already have a medal, look.’

2009-Odysseus-Haegeman-G091409.

¹ WF also has a set of final particles derived from adverbs: *zeker* (‘certainly’), *misschien* (‘perhaps’), *trouwens* (‘actually’) etc. Their interpretation and distribution is probably like that in Standard Dutch. For discussion of the standard Dutch equivalents see van der Wouden (2009). I hope to look at these in later work.

- f. Een- ze al een medalie da?
 have they already a medal *da*
 ‘Do they already have a medal?’

2.2. Clause type

DMs are not clause typers; they co-occur with clauses that are independently typed. Table 1 summarizes the compatibility of DMs with clause types and also the possibility of using them in isolation.² Some DMs (*mo*, *allè*, *gow*) are insensitive to clause type; other DMs are sensitive to clause type. *Zè* (and its variant *ghè*) belongs to the latter group: it co-occurs mainly with declaratives, and with some imperatives. As for interrogatives: only rhetorical questions seem possible with *zè/ghè* (hence my !(✓)). *Wè* and *zulle* typically co-occur with declaratives and imperatives and are incompatible with interrogatives. *Da* essentially occurs with interrogatives (Haegeman 1984, 1993, but see Cappelle 2003 and (6a) below)).

Table 1: Distribution of particles

DM	Position			Clause type		
	Initial	Final	Isolation	Declarative	Interrogative	imperative
<i>soei</i>	✓	✓	✓	✓	*	*
<i>mo</i>	✓	*	✓	✓	✓	✓
<i>allé, gow</i>	✓	✓	✓	✓	✓	✓
<i>né</i>	✓	✓	✓	✓	✓	✓
<i>wè/zulle</i>	*	✓	*	✓	*	✓
<i>zè/ ghè</i>	✓	✓	✓	✓	(✓)	!(✓)
<i>Da</i>	*	✓	*	!(✓)	✓	*

² A descriptive generalisation that emerges from the WF data and which has not previously been noticed is that only a DM that can be initial (*mo*, *alle*, *gow*, *soei*, *zè*, *ghè*, *né*) can also constitute an utterance by itself. Final DMs *da*, *we*, *zulle* cannot appear in isolation – i.e. as ‘interjections’. The generalisation extends to Dutch and to the Italian dialects analysed by Penello & Chinellato (2008a,b). Anticipating the discussion, the outcome of my analysis is that only DMs that are merged in the higher Speech Act Projection (cf. section 5) can be used as interjections. I hope to return to this point in future work.

(2)–(5) complement (1), illustrating additional clause types for the DMs. (2) shows the initial DMs *mo*, *gow*, *allè* with an interrogative and with an imperative. (3) illustrates *né* with an interrogative and with an imperative. (4) shows that *wè* and *zulle* are compatible with imperatives, but not with interrogatives. (5) shows *zè* with imperatives and with interrogatives.

(2) a. Mo/gow/allè, peinz-je gie da?
mo/gow/allè think-you you that
 ‘Come on, do you really think that?’

b. Mo/alle/gow, geeft dat ier!
mo/alle/gow, give that here
 ‘Come on, give me that!’

(3) a. Né, is-ze nie thus?
né is-she not home
 ‘Isn’t she in?’

b. Is ze nie thus, né?
 is she not home *né*
 ‘Isn’t she in?’

c. Doe ’t mee, né.
 do it with, *né*
 ‘Just take it with you, don’t worry!’

(4) a. Houkt ze mo, wè/zulle.
 Keep them PART *wè/zulle*
 ‘Don’t worry, you can keep them.’

b. *Een-me al een medalie wè/zulle?
 have we already a medal *wè/zulle*

- (5) a. Kyk/lustert (een kee) zè!
 Look/listen (PART) zè
 ‘Just look/listen.’
- b. Zie-j t neu zè?!
 know you it now zè
 ‘Do you understand/see now ?!’

The DM *da* is typically used with interrogatives (Haegeman 1984, 1993), but it can also be used with declaratives (Cappelle 2003). This is shown in (6a). Such declaratives have the rising intonation associated with questions, and (6a) as a whole is a request for confirmation and clarification of the content of the clause that precedes *da*. *Da* is incompatible with imperatives (6b).

- (6) a. Ze zoud al een medalie een da?
 she will-PAST-3SG already a medal have *da*
 ‘I hear she already have a medal.’
- b. * Geeft da mo da!
 give that PART *da*

2.3. Interpretation

2.3.1. DM express speaker’s attitude

Though the precise interpretive properties of the DMs are hard to pin down, they all share the following properties:

- (a) DMs are not truth-functional. For instance, all of (1a), (1c), (1d), and (1e) above share the propositional content ‘we already have a medal’. Questioning cannot focus on a DM, DMs are inaccessible to dissent or to consent, they are outside the scope of negation and tense.

(b) DMs are ‘conversational’ or ‘interactional’ and imply “the obligatory (and largely implicit) presence of the entities involved in the specific communicative situation (speaker and, especially, hearer)” (Munaro 2006:7, 2010). The interactional role of the DM is very clear with *né*. In initial position, when associated with declaratives, this DM initiates the exchange, it draws the hearer’s attention to the utterance; in final position, it can be used to conclude an exchange, as it were ‘transferring’ the content of the utterance to the addressee, in which case the presence of *né*, in concluding the exchange, may imply defiance (“Take that!”) or helplessness (“That’s how it is!”).

(c) DMs are ‘expressive’ (Kratzer 1999), or ‘illocutionary’/‘interpersonal’. The DM may express “the mental state of the speaker, which can be surprise, curiosity, desire, disappointment, anger and so on” (Munaro 2006:7, 2010). Several DMs qualify the already established relation between speaker and hearer: for instance, *wè* and *zulle* are used to ‘profile the speaker-hearer relationship’ (Kirsner & van Heuven 1996 and references cited): they convey that the speaker is in a relation of authority with respect to the hearer and to the content of his utterance.³ The speaker uses these DMs to underline and reinforce the propositional content of his utterance, suggesting his endorsement is based on his own experience, and (thus), depending on the content of the associated proposition, reassure his addressee or threaten him⁴ (cf. (8)).

(d) DMs are deictic. They are directly correlated with the speech act: they may express a response to a linguistic event or to a non-linguistic event which is manifest in the speech situation. The DMs examined in this paper are not discourse-bound in a narrow sense in that they do not need to be used in a response to a preceding utterance.

2.3.2. *Etymology and interpretation: verb-based DMs*

According to the descriptive literature, many of the WF DMs in initial or final position are verb-based. I briefly summarize their etymology as discussed in the literature here.⁵

³ With Hill (2007b:2009) I assume that the concept ‘utterance’ corresponds to ForceP.

⁴ At first sight, (West) Flemish *wè* and *zulle* correspond to Dutch *hoor* (Kirsner & van Heuven 1996).

⁵ WF also uses *kom* (‘come’), *kyk* (‘look’), and *zeg* (‘say’), with bleached semantics. These particles, which are also either initial or final, can also be used in isolation and are set off intonationally from the sentence with which they combine. Possibly they (always?) constitute separate utterances. Thanks to Ton

According to De Bo (1892:639), the WF DM *nè* is derived from the imperative *neem* ('take') of *nemen* ('take'). To present-day dialect speakers, the etymological connection between *nè* and the verb *nemen*, is not synchronically apparent, because, though *nemen* exists in the standard language, in the dialect the verb used to express the relevant sense is not *nemen* but *pakken* ('take')⁶. That De Bo's analysis of *né* is on the right track is suggested by the fact that in some other dialects the form *né* alternates with *ném*.

Flemish *né(m)* is analogous to French *tiens* ('take'), which may also convey surprise, to Veneto *ciapa* from V *ciapar* ('take from me'), which is also used sometimes as a particle expressing defiance (Penello p.c.) and to Italian *toh* ('take'). WF also uses *tiens* (or *tiens tiens*), borrowed from French, as a DM to express surprise:

(7) a. Tiens, m' een al een medalie.

tiens we have already a medal

'We already have a medal.'

b. M' een al een medalie, tiens.

we have already a medal *tiens*

'We already have a medal.'

According to Ryckeboer (1986), *wè*⁷ has developed either from *weet je* (lit. 'know you')⁸, or from *wil je* (lit. 'want you'/'will you'). The attested examples in (8a) and (8b), one dialectal and one from the *tussentaal*, illustrate *wè* used to underline that the speaker has personal experience of the content of the proposition conveyed in a statement and hence expects the addressee to accept what she/he is saying. This *wè* has falling intonation. In (8a), the speaker was discussing travel experience abroad. (8a) was followed by an illustration by the same speaker of similar problems experienced in

van der Wouden for discussion. Verb-based DMs are also found in French (*tiens, dis (donc)*), and in standard Dutch (*hoor, zeg, kijk*). For Italian see Penello & Chinellato (2008a,b), Poggi (1995) and also Cardinaletti (2011). See also Hill (2007b:2091-2) on the spread of Turkish *hai* in Slavic and Balkan languages.

⁶ Standard Dutch verbs derived from *nemen* are also replaced by those derived from *pakken*: *opnemen* ('record') for instance, is *oppakken*, and *innemen* ('take in') is *inpakken*.

⁷ Flemish *wè* and *zulle* correspond to Dutch *hoor* ('hear'). See Kirsner & van Heuven (1996) for the latter.

Belgium. In (8b), the speaker is explaining problems for academics in publishing, and in particular for those who, like herself, work on French linguistics. By using *wè* the speaker implies that she ‘knows what she is talking about’ and hence reinforces the reliability of the content of the utterance which it follows. With imperatives (8c), *wè* conveys that the speaker has the authority to perform the relevant speech act (order, advice) with respect to the addressee (and expects the addressee to respond appropriately).

(8) a. Je keut dat ier ook tegenkomen wè, zukken dingen.
 you can that here also meet-with *wè* such things
 ‘These things happen here too.’ (WF speaker, 13.10.08, overheard on the train)

b. Voor mensen die met Frans bezig zijn is dat anders
 for people who with French busy are is that different
wè.
wè
 ‘For people working on French, things are different, you know.’
 (*Tussentaal*, KL, WF speaker, 21.10.08, 18.30 telephone conversation)

c. Zet je mo wè.
 sit you PRT *wè*
 ‘Do sit down.’

Zulle is reported to be derived from the combination of modal *zul* and the second person pronoun (*zul je* ‘shall you’) and has a similar interpretation to *wè*. *Zulle* is widely used in the *tussentaal*.

According to De Brabandere (1999:528), *zè* is derived from the imperative of *zien* (‘see’). Anecdotal evidence shows that speakers still associate *zè* with *zien*. In subtitles on Flemish TV-channels, dialectal *zè* is rendered as *zie* (‘see’). French *voice* (lit. ‘look here’) decomposes into *voi-* (‘see’) and *ci* (‘here’). The (archaic) Dutch analogue of *voici* is *zie hier* (lit. ‘see here’). *Ziehier* in turn corresponds to *hierzie* in the

⁸ The DM *witte* (‘you know’) in the Antwerp dialect does not have exactly the same distribution as WF

tussentaal, and to WF *hierzè*, which consists of *hier* ('here') and *zè*. The *tussentaal* analogue of *zè* is *zie* (9).

(9) Ik ga nu weer gaan verbeteren zie.

I go now again go correct *zie*

'I am off to do some more corrections.' (MvH, female speaker 05.02.2009, 13.30)

Initial *zè*, with rising intonation, is used to draw the addressee's attention. Final *zè* has two uses. With rising intonation it is used to draw the addressee's attention. With falling intonation, the function of *zè* resembles that of *wè*: it has an evidential function and signals that the discourse context provides direct or indirect evidence for the content of the utterance. Like with *wè*, this use of *zè* is implicated in bonding between speaker and hearer: by its implication that there is independent evidence, *zè* reinforces the reliability of the content of the associated utterance. Though I will not develop the syntax of *zè* here, it is relevant to point out that two occurrences of final *zè* may co-occur as illustrated in (10). In (10a), initial *zè* with a rising intonation is attention-seeking and final *zè* with a falling intonation is 'evidential' in the sense described above. In (10b) the first leftmost occurrence of *zè* has falling intonation and is evidential, and the second occurrence (with rising intonation) is attention-seeking.

(10)a. Zè, k'een gedoan zè.

Zè I have done zè

'I have finished, see.'

b. K'een gedoan zè, zé.

Injunctive *gow* ('come on') is reported to derive from the verb *gaan* ('go') + *weg* ('away') (De Bo 1892:300; Desnerk 1972:52). Thus *gow* would be parallel to the DM *allé*, which derives from the imperative of the French verb *aller* ('go'). *Gow* and *allé* are

wè (Kathleen Pierloot, p.c).

used as injunctives and are widespread in the Flemish dialects and in the *tussentaal* (Kloots 2007).⁹

2.4. The distribution of the Discourse Markers

The DMs we are concerned with in this paper are restricted to root clauses and are excluded from the left periphery of embedded clauses (11). Final DMs always scope over the root clause. For instance, *da* cannot be associated with an embedded domain (12).

(11) * Je zei né dat da roare was.
He say-PAST-3SG *né* that that strange be-PAST-3SG

(12) * Je vroeg wanneer/ of dan 'k gingen veruzen
he ask-PAST-3SG when/ whether that-1SG I go-PAST-1SG move-house
da.
da

Initial DMs precede declarative subject-initial (13a) or non-subject-initial root V2 clauses (13b). The DM cannot occur in a medial position. The DM also precedes a root question, whether it be a *wh*-question (14a) or a *yes no* question (14b), and it precedes imperatives. Final *wè* precedes, and final *né* follows, a dislocated DP (15a)-(15b); final *zè* can either precede or follow such material (15c). I will return to this point in section 4, where I will argue that there are two positions for final DMs, one to the left of a dislocated DP and one to the right.

(13)a. Né, m' een (**né*) al een medalie.
né we have *né* already a medal
'I say, we have a medal!'

⁹ *Gow* and *allé* are similar to Turkish *hai*, which has spread to Balkan and Slavic languages (cf. Hill

b. Né, dienen medalie (*né) een me (*né) a.
né that medal né have we né already
'There we are, that medal is ours.'

(14)a. Né, wat (*né) ee- j (*né) gie (*né) doa?
né what né have-you né you né there
'What is that you've got there?'

b. Né, is (*né) da (*né) van jun?
né is né that né of you
'Is that yours?'

c. Né, doet (*né) da (*né) mo mee!
né do né that né PRT with
'Here you are: you can have this.'

(15)a. 't Is gereed wè, men artikel.
it is ready wè my paper
'My paper is ready, you know.'

b. 't Is gereed men artikel, né

c. T'is gereed (zè), men artikel (zè).

3. A pilot study: WF *né* and *wè*

3.1. *The central data*

In the remainder of this paper, I set out a framework for the syntactic analysis of the WF DMs, *né* and *wè*, illustrated in (16) and (17). Future work will examine to what extent the analysis can be extended to the other DMs in WF and cross-linguistically.

Né can be either initial (16a) or final (16b), and it has rising intonation. In (16a), *né* initiates the utterance and focuses the addressee's attention to the content of the utterance. In (16b), *né* winds up the utterance and 'transfers' it to the addressee. The DM *wè*, with falling intonation, is necessarily final (17); *wè* qualifies the speaker-hearer relation, establishing that the speaker has the authority (with respect to the hearer as well as with respect to the content of the utterance) to make the utterance.

(16)a. *Né*, men artikel is gedoan.
né my paper is done
'There we go: my paper is finished.'

b. Men artikel is gedoan, *né*.

(17)a. **Wè*, men artikel is gedoan.
wè my paper is done

b. Men artikel is gedoan *wè*.

When *né* and *wè* co-occur, their distribution is as shown in (18). (18a) illustrates the split pattern: *né* precedes the clause and *wè* follows it. The opposite split order is ungrammatical (18b). When both DMs follow the clause, *né* must be to the right of *wè* (18c,d). Since *wè* must follow the clause, any alternatives with *wè* in initial position are excluded (18e).

(18)a. *Né*, men artikel is gedoan *wè*.

b. **Wè*, men artikel is gedoan *né*.

c. Men artikel is gedoan *wè né*.

- d. *Men artikel is gedoan né wè.
- e. *Né wè/*Wè né men artikel is gedoan.

It is important to also briefly turn to the interaction with other DMs because this reveals that, when final, the DMs *né* and *wè* pattern differently. Both final *né* and final *wé* can co-occur with final *zé*: however, *né* follows *zé* (19a,b), while *wè* precedes *zè* (19c,d). The function of *zè* differs in the two cases. In (19a) *zè*, with falling intonation, has its ‘evidential’ function, corresponding to the leftmost instantiation of *zè* in (10b) and in (15c). In (19c), with rising intonation, *zè* has the attention-focusing use, corresponding to the rightmost instantiation of *zè* in (10b) and in (15c). So final *né* is in complementary distribution with final attention-drawing *zé*, and final *wè* is in complementary distribution with final ‘evidential’ *zè*.

- (19)a. Men artikel is gedoan zè né.
- b. *Men artikel is gedoan né zè.
- c. Men artikel is gedoan wè zè
- d. *Men artikel is gedoan zè wè.

3.2. *Only two positions for DMs*

Though final *né* can co-occur with final *zè* (19a) and with final *wè* (18c), and though final *wè* can also co-occur with final *zè* (19c), the three DMs cannot co-occur, regardless of the orders (20). (20b) and (20d) are acceptable with *né* clearly set off from the following segment and I would analyze these as involving an isolated interjection. (20) suggests that in the unmarked case there are just two slots for final DMs. I will leave the full analysis of *zè* for future work.

- (20)a. *Men artikel is gedoan wè zè né.
- b. Men artikel is gedoan wè zè. Né!
- c. ??* Né, men artikel is gedoan wè zè.
- d. Né! Men artikel is gedoan wè zè.

3.3. *The syntax of discourse markers*

My analysis of the WF DMs *né* and *wè* is inspired by seminal work on particles by Munaro & Poletto (2003) and will prove striking confirmation for the hypothesis of Hill (2007a,b) on the syntactic representation of the speech act. Munaro & Poletto (2003, 2009) were the first to propose that particles head functional projections and may attract the clause they select to their specifier.¹⁰ They propose that particles head functional projections in the CP layer and that, when final, they attract their clausal complement to their specifier. Observe that the derivation in (21) violates the anti-locality condition on movement in that a complement is moved to the specifier of the head that selects it (cf. Abels 2003, Grohmann 2003, Aboh 2004). I return to this point in section 4.2 below.

(21) $[_{FP} \text{Int-ForceP}_i [_{F^\circ} \textit{particle}] [_{\text{Int-ForceP}} t_i]]$ (Munaro & Poletto 2009:286)

As already noted, WF initial DMs precede the initial constituent of a V2 root clause and they cannot be embedded. If we assume, in terms of Rizzi's split CP, that the initial constituent in a V2 clause occupies SpecFocP or SpecTopP for non-subject-initial V2 and SpecFinP for subject-initial V2 (see Haegeman 1996, van Craenenbroeck & Haegeman 2007), we might propose that the Flemish DM is merged in ForceP, the topmost projection of the left periphery. However, at least two problems arise for this proposal. First, WF DMs are not clause typers: they do not determine the illocutionary force of the clause they associate with; some DMs select for a clause which has a

¹⁰ See Munaro (2006:9-10, (43)) for an update of the analysis.

particular Force. Secondly, it is usually assumed that there is one projection ForceP, which types the clause, while in WF two DMs can co-occur, suggesting that two projections are involved. Differently from what is proposed for the clause-typing particles discussed for Northern Italian dialects (Munaro & Poletto 2003, 2009, Munaro 2006), let us assume that the lower WF DM selects ForceP (see also Hill 2007a:80 (22), 2007b for similar proposals based on Romanian), and that the higher DM selects the projection of the lower DM. I will revise this initial hypothesis on the basis of additional data. I label the projections headed by DMs ‘PartP’, but this does not imply that I take a stance on the validity of postulating a category ‘particle’.

There have been a number of proposals in the literature that postulate a functional domain above ForceP as the interface between the clause and the discourse and that “sorts out the discourse setting for the utterance” (Hill 2007a:78). The labels for such projections come in two ‘flavours’. Some of these labels bring to the fore the performative aspect of speech acts and the anchoring of the utterance in the discourse. For instance, Benincà (2001) labels this domain *DiscourseP* (cf. also Garzonio 2004), Hill (2006:180) uses the label *PragP*, Hill (2007a,b) proposes an articulated *Speech Act Projection* (‘SAP’), a point to which I return in section 5. Other labels reflect the speaker’s relation to the utterance. For instance, Speas & Tenny (2003), Speas (2004) and Tenny (2006) associate the high projection with modal values (see also Hill 2007a); based on Chinese data Paul (this volume) proposes the label *Attitude*. That two types of labelling are proposed may not be accidental. As already suggested above, WF offers evidence for postulating two projections on the interface between clause and discourse, which will be discussed in more detail in section 5.

4. Speech act syntax

4.1. Sentence-final DMs: a spec-head relation?

Starting from Munaro & Poletto’s work, let us assume that DMs select a clausal complement (here labelled *CP*), and that final DMs attract the clause to their specifier.

With *né*, attraction is optional (22a,b).¹¹ With *wè*, it is mandatory (22c). Since two DMs can co-occur either in a split configuration, with *né* initial and *wè* final, or, in a configuration with both DMs final, with *wè* preceding *né*, we conclude that two projections must be available, where *né* selects the projection headed by *wè* (23a), deriving the split order. When *né* attracts its complement to its specifier, the two DMs will be final, with *wè* preceding *né*.

(22)a. $[_{FP} [_{F^{\circ}} né] [_{CP} CP]]$

b. $[_{FP} CP [_{F^{\circ}} né] [_{CP} \cancel{CP}]]$

c. $[_{FP} CP [_{F^{\circ}} wè] [_{CP} \cancel{CP}]]$

(23)a. $[_{FP1} [_{F1^{\circ}} né] [_{FP2} CP_i [_{F2^{\circ}} wè] [_{CP} \cancel{CP}]]]$

b. $[_{FP1} [_{FP2} CP_i [_{F2^{\circ}} wè] [_{CP} \cancel{CP}]] [_{F1^{\circ}} né] [_{FP2} \cancel{CP}_i [_{F2^{\circ}} wè] [_{CP} \cancel{CP}]]]$

4.2. DMs and vocatives

As it stands, (23) leads to the prediction that (i) initial *nè* will be adjacent to the clause it is associated with, (ii) final *wè* and *né* will be adjacent to the fronted CP, and (iii) final *wè* and *nè* will be adjacent. A problem for the analysis is that, like (21), (22c) and (23b) violate anti-locality conditions on movement.

When we examine the distribution of vocatives in relation to DMs, the adjacency prediction is confirmed for the relation between *wè* and the fronted clausal constituent, as shown in (24a) and (24b): sentence-final *wè* cannot be separated from the clause it modifies by a vocative, which has to follow *wè*:

(24)a. *Men artikel is gereed Valère wè.
 my paper is ready Valère wè

¹¹ In section 5, I will propose an analysis according to which the optionality is be apparent.

- b. Men artikel is gereed wè, Valère.

The adjacency prediction is, however, not confirmed for *né*, neither in initial nor in final position. With initial *né*, the order in (23a) is hard to reconcile with the head-complement relation between *né* and the clause postulated in (22a). Final *wè* is right-adjacent to the clause to its left and immediately precedes the vocative. We have already seen that final *né* patterns differently from final *wè* in relation to the DM *zè*, suggesting they occupy a different position (19). This is confirmed by the distribution of the final DMs in relation to vocatives: while *wè* precedes a final vocative, *né* may either precede or follow a final vocative. In (25b), the particle is a separate prosodic unit, and the vocative is prosodically associated with the preceding clause, while in (25c), the vocative forms a prosodic unit with the DM. According to (23b), final *né* and final *wè* should be adjacent. This prediction is not confirmed: a vocative will preferably be found between the two particles (25d).

(25)a. Né Valère, men artikel is gereed.
né Valère, my paper is ready

- b. Men artikel is gereed, Valère, né.

- c. Men artikel is gereed, né Valère.

- d. Men artikel is gereed wè Valère né.

For completeness' sake, note that in the split pattern with initial *né*, the vocative follows either *nè* (26a) or *wè* (26b) and that the vocative can also precede the clause with final *wè* (26c).

(26)a. Né Valère, men artikel is gereed wè.

- b. Né men artikel is gereed wè Valère

c. Valère, men artikel is gereed wè.

(27) schematically summarizes the distribution of the DMs in relation to the vocative:

(27)a. *né* (voc) CP

b. CP (voc) *né* (voc)

c. (voc) CP (*voc) *wè* (voc)

d. CP (*voc) *wè* (voc) *né* (voc)

I take the fact that a vocative can separate initial *né* from the clause to its right to mean that sentence-initial *né* does not directly select a clausal complement. As a first approximation, the structure hosting *né* could be represented as in (28), where *né* heads a projection, here labeled *PartP*, and selects FP, which hosts the vocative in its specifier and which has as its complement a clausal projection, here labeled *CP* (for a discussion of vocatives in terms of the split CP, see Moro 2003). In (28a), the clause selected by *né* remains in its merge position; in (28b), it moves to the specifier of *né*. I return to these two variants in section 5. The same representation can be proposed for the projection headed by *wè*. Differently from *né*, however, *wè* forces the movement of ForceP from the complement position of F to its specifier. Note that the leftward movement of CP in (28b) and (28c) no longer violates anti-locality:

(28)a. [_{PartP} [_{Part} *né*] [_{FP} VOC [F] [_{ForceP} CP]]]

b. [_{PartP} CP [_{Part} *né*] [_{FP} VOC [F] [_{ForceP} ~~CP~~]]]

c. [_{PartP} CP [_{Part} *wè*] [_{FP} VOC [F] [_{ForceP} ~~CP~~]]]

I will assume that, in the absence of an overt vocative FP, the projection that hosts it, is still available, with the specifier either not realized or with a null specifier that gets a default reading. I return to this point below, where I identify the nature of FP.

- (29)a. $[\text{PartP } [\text{Part } n\acute{e}] [\text{FP } [\text{F}] [\text{ForceP } \text{CP}]]]$
- b. $[\text{PartP } [\text{CP}] [\text{Part } n\acute{e}] [\text{FP } [\text{F}] [\text{ForceP } \text{CP}]]]$
- c. $[\text{PartP } [\text{CP}] [\text{Part } w\grave{e}] [\text{FP } [\text{F}] [\text{ForceP } \text{CP}]]]$

Let us assume that the PartP headed by *né* dominates the PartP headed by *wè* and that these PartPs each select a specialized position for the vocative in SpecFP (as in (29)). To differentiate the projections, I have identified them as *PartP1* and *PartP2*, where PartP1 dominates PartP2, and I have also numbered the FP hosting vocatives accordingly. (30a) represents the split pattern with initial *né* and final *wè*; (30b) derives the combination of final *wè* and final *né*: PartP2, headed by *wè*, moves to the specifier of *né*.

- (30)a. $[\text{PartP1 } [\text{Part1 } n\acute{e}] [\text{FP1 VOC } [\text{F1}] \text{ } [\text{PartP2 } [\text{CP}] [\text{Part } w\grave{e}] [\text{FP2 VOC } [\text{F2}] [\text{ForceP } \text{CP}]]]]]$
- b. $[\text{PartP1} [\text{PartP2 } [\text{CP}] [\text{Part2 } w\grave{e}] [\text{FP2 Voc } [\text{F2}] [\text{ForceP } \text{CP}]]] [\text{Part1 } n\acute{e}] [\text{FP1 VOC } [\text{F1}] [\text{PartP2 } \text{PartP2}]]]$

Following Hill (2007b), I will assume that PartP1 and PartP2, and the associated FP1 and FP2, constitute the speech act layer, i.e. a syntactically encoded interface between the utterance and the discourse.¹² The structure postulated here contains two positions for vocatives. I return to both these points in section 5. I will assume that the speech act layer is projected even in the absence of an overt DM.¹³

¹² Hill's proposals are of course reminiscent of earlier approaches such as Ross (1970) and Banfield (1982).

¹³ Perhaps in non-interactive speech or writing the projections might be truncated along the lines of Haegeman (2007).

With initial *né*, the vocative either precedes or follows the clause (26a,b), depending on whether it occupies SpecFP1 or SpecFP2 respectively (31a). With final *né*, the vocative is either right adjacent to *né* (25c) or right adjacent to the clause (25b). (31b) derives the two positions of the vocative with final *né*: the rightmost position corresponds to SpecFP1 and the leftmost position corresponds to SpecFP2. With only *wè* instantiated, the vocative in SpecFP1 will be initial (26c), and that in SpecFP2 will follow *wè* (24b). These positions are derived as in (31c):

- (31)a. [_{PartP1} [_{Part1} *né*] [_{FP1} VOC [F1] [_{PartP2} [CP] [_{Part2}] [_{FP2} VOC [F2] [_{ForceP} ~~CP~~]]]]]
- b. [_{PartP1} [_{PartP2} [CP] [_{Part2}]] [_{FP2} VOC [F2] [_{ForceP} ~~CP~~]] [_{Part1} *né*] [_{FP1} VOC [F1] [_{PartP2} ~~PartP2~~]]]
- c. [_{PartP1} [_{Part1}] [_{FP1} VOC [F1] [_{PartP2} [CP] [_{Part2} *wè*] [_{FP2} VOC [F2] [_{ForceP} ~~CP~~]]]]]

Since Part2 is associated with ‘final’ DMs, I assume that Part2 always attracts the clausal constituent (abbreviated as CP in the representations). Thus, as shown in (32b) and (32c), in the absence of any overt DMs, a clause can be preceded (SpecFP1) or followed (SpecFP2) by a vocative.

- (32)a. [_{PartP1} [_{Part1}] [_{FP1} Voc1 [F1] [_{PartP2} [CP] [_{Part2}] [_{FP2} Voc2 [F2] [_{ForceP} ~~CP~~]]]]]
- b. Valère, k’een gedoan.
 Valère I have done
 ‘Valère, I have finished.’
- c. K’een gedoan, Valère.

4.3. DMs and dislocated material

Haegeman (1984, 1993) shows that dislocated material appears to the right of the final particle *da* in WF. For reasons of space, I only look at dislocated DPs here. Dislocated DPs follow final *wè* (33), precede final *né* (34) and separate final *wè* and *né* (35). Note incidentally that once again final *wè* and *né* are not adjacent.

(33)a. 't Is gereed wè, men artikel.
it is ready wè my paper

b. * 't Is gereed, men artikel, wè.

(34)a. 't Is a gedoan men artikel, né.
it is already done my paper né

b. * 't Is a gedoan né, men artikel.

(35)a. 't Is a gedoan wè men artikel, né.
it is already done wè my paper né

b. * 't Is a gedoan men artikel wè, né.

c. * 't Is a gedoan we né men artikel.

It would go far beyond the scope of the current paper to provide a full discussion of the syntax of WF dislocated DPs. I will provisionally assume that a right-dislocated DP is merged in a projection dominating ForceP (here provisionally labeled *DisIP*)¹⁴ and that it is stranded by leftward movement of ForceP. In sentences with split DMs containing a dislocated DP, the representation will be as in (36a), with *wé* to the left of the stranded DP. With final *né*, movement of PartP2 into the spec of *né* piedpipes the dislocated DP, which ends up to the left of *né*, but remains to the right of *wè*, as in (36b). Since stranding of the dislocated DP to the right of *né* is ungrammatical (35c) we must

¹⁴ Cf. the clause external topic in Hill (2006:164).

conclude that CP movement from SpecPartP2 to SpecPartP1 is prohibited. This must be either because Part1 attracts PartP2, or else that the CP in SpecPartP2 piedpipes PartP2.

- (36)a. [_{PartP1} [_{Part1} *né*] [_{FP1} [F1] [_{PartP2} [CP] [_{Part2} *wè*] [_{FP2} [F2] [_{DisIP} DP [_{ForceP} **CP**]]]]]]]
- b. [_{PartP1} [_{PartP2} [CP] [_{Part2}] [_{FP2} [F2] [_{DisIP} DP [_{ForceP} **CP**]]]]][_{Part1} *né*] [_{FP1} [F1] [_{PartP2} **PartP**]]]

4.4. DMs, vocatives and dislocated material

(37) contains *wé*, a dislocated DP and a vocative. The vocative is either initial (37a), or it follows *wè* and precedes the dislocated DP (37b). (37c) with the vocative after the dislocated material is quite marginal. These patterns are derived by the structures elaborated here. In (37a), the vocative is in SpecFP1 and in (37b), it is in SpecFP2. (37c) would be a case in which the vocative is in SpecFP1 and the null Part1 attracts PartP2. I provisionally assume that the null Part1 is not an attractor, but this hypothesis remains to be looked at more carefully, because I assume that Part2 is always an attractor, even when there is no overt filler, as for instance in (32).

(37)a. Valère, 't is gereed wè, men artikel.

b. 't Is gereed wè, Valère, men artikel.
it is ready wè Valère my paper

c.?? 't Is gereed, wè, men artikel, Valère.

d. [_{PartP1} [_{Part1}] [_{FP1} VOC [F1] [_{PartP2} [CP] [_{Part2} *wè*] [_{FP2} VOC [F2] [_{DisIP} DP [_{ForceP} **CP**]]]]]]]

With only sentence-initial *nè* and a dislocated DP, the vocative either immediately follows *né*, with the dislocated DP final, or the vocative immediately precedes the

dislocated DP. According to (38c), the vocative in (38a) is in SpecFP1, while that in (38b) is in SpecFP2.

(38)a. Né, Valère, 't is gedoan, men artikel.

b. ?? Né, 't is gedoan Valère, men artikel.

c. [PartP1 [Part1 *né*] [FP1 VOC [F1] [PartP2 [CP] [Part2] [FP2 VOC [F2] [DisIP DP [ForceP ϵ P]]]]]]]

With split DMs, the vocative either immediately follows *né*, or, more marginally, it follows *wè* and immediately precedes the dislocated DP. (39c) represents (39a), (39d) represents (39b).

(39)a. Né Valère, 't is gedoan wè, men artikel.

b. ?Né, 't is gedoan wè, Valère, men artikel.

c. [PartP1 [Part1 *né*] [FP1 VOC [F1] [PartP2 [CP] [Part2 *wè*] [FP2 [F2] [DisIP DP [ForceP ϵ P]]]]]]]

d. [PartP1 [Part1 *né*] [FP1 [F1] [PartP2 [CP] [Part2 *wè*] [FP2 Valère [F2] [DisIP DP [ForceP ϵ P]]]]]]]

With only final *né* and a dislocated DP, the vocative either follows *né*, see (40a), or it precedes *né* and the dislocated DP, see (40b), the latter order more marginal. (40c) with the vocative to the left of *né* and to the right of *men artikel* ('my paper') is out. The orders are derived by the structures proposed, see (41): for (40a), the vocative is in SpecFP1 (41a); for (40b), the vocative is in SpecFP2 (41b). (40c) cannot be derived, if the dislocated DP does not move.

(40)a. ? 't Is a gedoan, men artikel, né Valère.

it is already finished my paper *né* Valère

b.?? 't Is a gedoan, Valère, men artikel, né

c. * 't Is a gedoan men artikel, Valère, né.

(41)a. [_{PartP1} [_{PartP2} [_{CP} [_{Part2}] [_{FP2} [_{F2}] [_{DisIP} DP [_{ForceP} **CP**]]]] [_{Part1} *né*] [_{FP1} VOC [_{F1}] [_{PartP2} **PartP2**]]]]

b. [_{PartP1} [_{PartP2} [_{CP} [_{Part2}] [_{FP2} VOC [_{F2}] [_{DisIP} DP [_{ForceP} **CP**]]]] [_{Part1} *né*] [_{FP1} [_{F1}] [_{PartP2} **PartP2**]]]]

When both DMs are final, the preferred orders are as in (42): the vocative is either to the immediate right of *wè* (see (42a)) or to the immediate right of *nè* (see (42b)), the latter more marginal. These orders are derived as in (42c) and (42d): the vocative to the immediate right of *wè* is that associated with FP2; that to the right of *nè* is that in FP1.

(42)a. ? 't Is a gedoan *wè* Valère, (**wè*) men artikel (**wè*), né
it is already done *wè* Valère *wè* my paper *wè* *né*

b.?? 't Is a gedoan, *wè* men artikel, (**wè*) *né* Valère.

c. [_{PartP1} [_{PartP2} [_{CP} [_{Part2} *wè*] [_{FP2} VOC [_{F2}] [_{DisIP} DP [_{ForceP} **CP**]]]] [_{Part1} *né*] [_{FP1} [_{F1}] [_{PartP2} **PartP2**]]]]

d. [_{PartP1} [_{PartP2} [_{CP} [_{Part2} *wè*] [_{FP2} [_{F2}] [_{DisIP} DP [_{ForceP} **CP**]]]] [_{Part1} *né*] [_{FP1} VOC [_{F1}] [_{PartP2} **PartP2**]]]]

The speech act layer elaborated above consist of two functional projections ('PartP'), whose heads host DMs, and two projections (labeled 'FP') whose specifiers host vocatives. In the next section, I re-examine and reinterpret the nature of these functional projections.

5. Particle projections and vocatives

Based on the distribution of DMs, vocatives and dislocated DPs in WF, I have elaborated the articulated structure in (43a), with *CP* here an abbreviation for ForceP and projections containing dislocated material.

(43)a.

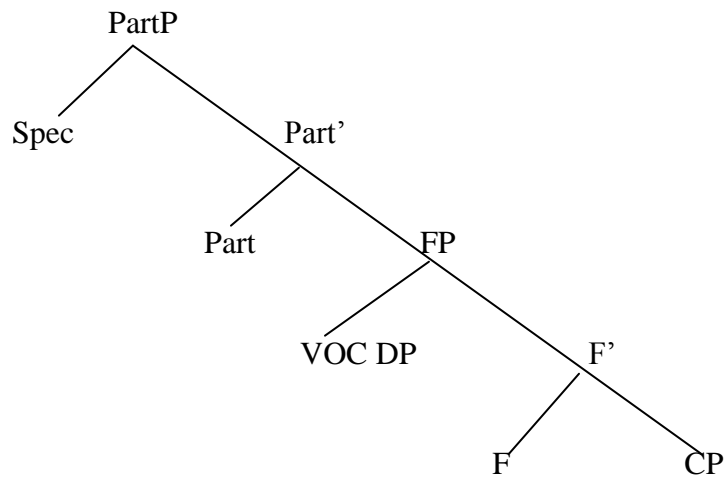

Each DM comes with a vocative DP and a CP. The representation above does not capture the relation between these three components, however. To encode the relation between the projection of the DM ('PartP'), and that of the vocative ('FP'), I propose to replace (43a) by the layered functional structure in (43b), with two PartP shells: Part projects a lower shell (corresponding to FP) and a higher shell (corresponding to PartP). The DM is merged in the lower Part head and moves to the higher head (in the same way that a lexical verb is merged in V and moves to v).

(43)b.

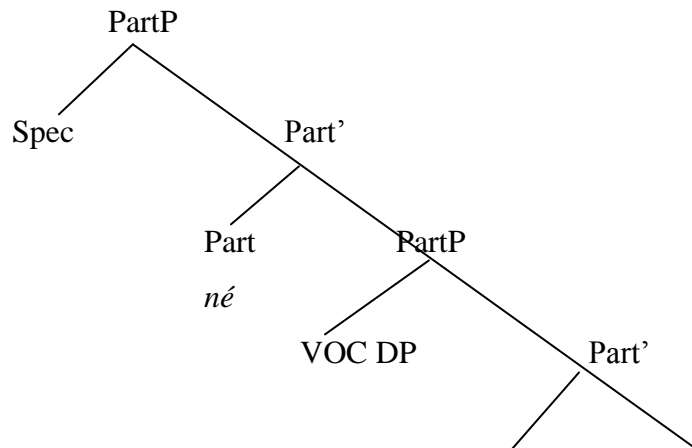

(43b) was postulated entirely on the basis of WF data and standard assumptions about phrase structure representations. Interestingly, though, in terms of the architecture of the projections, (43b) is strikingly similar to (43c), the ‘Speech act shell’ proposed by Hill (2007b:2009) on the basis of the distribution of the verb-based particle *hai* (‘come’) and vocatives in Romanian. In (43c), Hill’s $\text{RoleP}_{\text{hearer}}$ hosts the vocative. Hill explicitly says that “Speech Act heads have [V]-features” (2007b: 2078). This is very much in line with the fact that the WF DMs studied here are all verb-based. This suggests indeed that the DMs, if anything, are of the category V, with a bleached semantics compared to lexical verbs. For Hill, the speech act layer corresponds to a projection with V-features with 3 arguments: speaker, hearer and utterance. Put differently, (43c) is like the projection of a transitive verb. Hill (2007a,b) does not consider the possibility of there being unaccusative variants of (43c),¹⁵ but we will see presently that WF may provide evidence for that.

(43)c.

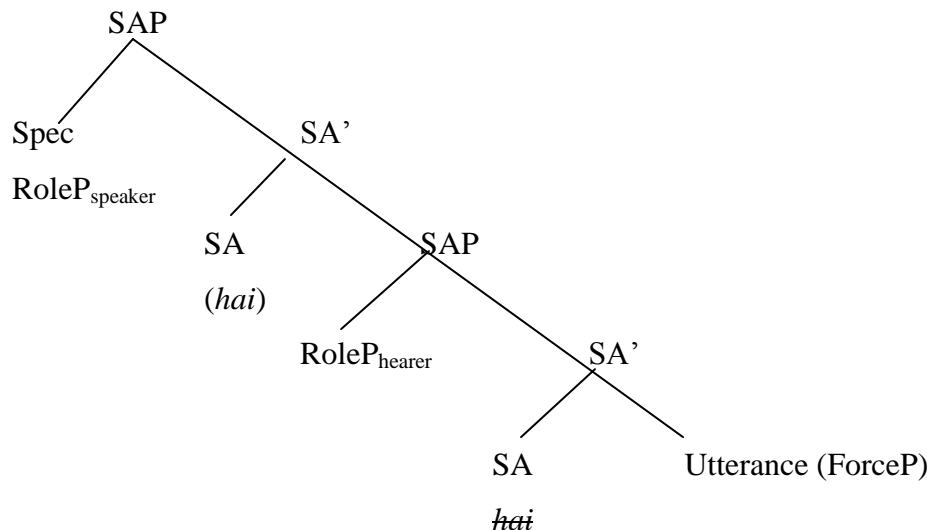

My analysis departs from Hill’s (2007a,b, 2009) in a number of respects, of which I discuss two here.

¹⁵ But see note 16.

(i) Hill (2007a,b, 2009) postulates just one SAP. Based on the distribution of WF DMs, I adopt the hypothesis that there are two speech layer projections. The interpretative properties of the two speech act projections are distinct. I will sketch the core differences as I identify them at this stage and return to this point in future work. The higher speech act projection can host the DM *né*. Initial *né* initiates and establishes the discourse relation between speaker and hearer, catching the addressee's attention, and directing his focus to the content of the utterance. The vocative associated with *né* has the function of a 'call' vocative (Schegloff 1968, Zwicky 1974, Portner 2004a,b, Schaden 2010, Shiina 2005): it serves to identify one (or more) individual(s) (among a set) as the addressee(s) to whom the utterance is directed. Final *né* closes off the utterance and transmits its content to an addressee. The vocative to the right of *né* is like Portner's 'tag' vocative (2004b:7) in that it re-establishes the addressee. Based on the functions of *né*, I tentatively characterize the higher SAP as 'dynamic' and 'directional': it relates the utterance to an addressee as the one for whom the utterance is intended.

The lower speech act shell is headed by *wè*. (Final) *wè* is used to consolidate and possibly qualify the already established speaker-addressee relationship in relation to the content of the utterance: *wè* signals that the speaker has the authority to make the statement or give the order. The vocative associated with *wè* does not serve to identify the addressee within the set of potential addressees; rather the vocative is an 'address vocative' in the sense of Schegloff (1968): it is "designed to maintain or emphasize the contact between speaker and addressee" (Schaden 2010:3-4). This vocative has a 'bonding' function: the speaker qualifies or reaffirms the already established relationship with his hearer. By his lexical choice of the term of address, the speaker ('Valère', 'my friend', 'you idiot', 'sweetie', etc.) will also qualify his relation with the hearer. Tentatively we can say that the lower SAP/PartP is 'stative', it is more 'attitudinal' (cf. Paul, this volume).

Recall that I pointed out in section 3.3. that the terminology used to identify and label the relevant syntactic domain in the literature on the representation of speech acts was ambivalent, referring, on the one hand, to the speech act as a performative (see especially Hill 2007b) and, on the other hand, referring to speaker attitude (Paul, this volume), and also to modal (especially evaluative) values (Speas & Tenny 2003, Speas 2004, Tenny 2006). This observed divergence in the labeling no longer seems accidental

if, as I argue, two speech act projections are present: the higher projection is more directly related to the performative aspect of the speech act, initiating the hearer-speaker relation. The lower projection modulates the (already established) relation between speaker and hearer, and thus corresponds to the *Attitude projection* identified by Paul (this volume) for Chinese.

I have shown that the DM *zè* has a double function, and that it may even appear twice in one utterance, either in the split pattern (10a) or with two instances in final position (10b). We can relate these two occurrences to the two projections postulated here. The question arises, then, if we need to postulate two items *zè*, one inserted in Part1 and the other in Part2, or whether *zè* is underspecified and can thus be inserted in either projection.

(ii) Hill (2007a,b) represents the Speaker role in the specifier of the topmost SAP (43c).¹⁶ Since I assume that CP moves into the specifier of the lower PartP2 (which would correspond to a lower SAP), and that PartP2 itself may move to SpecPart1, I cannot completely adopt this proposal. Recall that SAP has [V]-features, echoing the verb-based nature of Hill's *hai* (2007b) and of the WF DMs. A line that I will pursue in future work is to take the verb properties of the higher speech act layer seriously and to propose that the relevant verb heads come in a transitive and an unaccusative variety. With initial DMs, Part1 is like a transitive 'v' and assigns the speaker role to its specifier. When PartP2 moves to SpecPart1, Part1 is unaccusative, and does not theta-mark an external argument. Observe that this proposal also eliminates the optionality in PartP2 movement. Part2, which always triggers movement, must also be unaccusative.

6. Conclusion and questions for future research

The paper sets out a framework for the analysis of DMs in WF. Based on the relative positions of the DMs *né* and *wé*, vocatives and dislocated DPs, and on standard assumptions about clause structure, a structure has been elaborated which matches

¹⁶ Hill (2009) allows for CP movement to the specifier of her SAP in order to account for the final position of the vocative in (i):

(i) I can't do this, John.

She assumes one unique vocative position, with the different interpretations of initial and final vocatives being pragmatically determined.

independent work by Hill (2007a,b). The WF data thus provide clear independent support for her proposals.

The analysis proposed here is based on two DMs. With respect to the WF data, many questions, however, still remain to be addressed. For instance, the analysis does not yet cover all the nuances of meaning that the two DMs convey. Further research is also needed to establish to what extent other WF DMs can be analyzed along the lines outlined here and how to characterize the shades of interpretation associated with them (see Cappelle 2003). With respect to DMs such as *zè*, briefly discussed above, which head either the lower or the higher projection, with appropriate differences in interpretation, the question arises if this is a case of an underspecified DM or of two different DMs *zè*.

The projections identified here are headed by verb-based particles. Hill (2007b) illustrates a similar phenomenon in Romanian. It would be important to examine to what extent the analysis developed here can account for the distribution of verb-based DMs in other languages.

Hill (2007a) proposes that Romanian adverbs such as *sigur* ('surely') and *fireste* ('naturally') may head SAP. In WF, the same adverbs can also appear at the fringe of the clause (45) and it is important to determine their distribution in relation to the DMs described here and in relation to the speech act layer.

(45)a. *Natuurlijk, zen artikel is niet gereed.*

naturally, his article is not ready

'Of course, his paper isn't ready.'

b. *Zen artikel is niet gereed, zeker?*

his paper is not ready, certainly

'I suppose his paper isn't ready?'

I hope to return to these (and other) issues in future work.

References

- ABELS, Klaus. 2003. *Successive cyclicity, anti locality and adposition stranding*. University of Connecticut, Ph.D. dissertation.
- ABOH, Enoch. 2004. Snowballing movement and generalized pied piping. *Triggers*, eds. A. Breitbarth & H. van Riemsdijk, 15–47. Berlin: Mouton de Gruyter.
- BANFIELD, Ann. 1982. *Unspeakable sentences: narration and representation in the language of fiction*. London: Routledge.
- BENINCÀ, Paola. 2001. The position of topic and focus in the left periphery. *Current studies in Italian syntax. Essays offered to Lorenzo Renzi*, eds. Guglielmo Cinque & Giampaolo Salvi, 39–64. Amsterdam: Elsevier.
- CAPPELLE, Bert. 2003. Het gebruik van het Brugse dialoogpartikel *dè*. *Neerlandistiek.nl*, 03.01.
- CARDINALETTI, Anna. 2011. German and Italian modal particles and clause structure. *The Linguistic Review* (28/4): 493–531.
- CONIGLIO, Marco. 2007. German modal particles in root and embedded clauses. *Rivista di Grammatica Generativa* 32, 13–37.
- CRAENENBROECK Jeroen van & HAEGEMAN, Liliane. 2007. The derivation of subject-initial V2. *Linguistic Inquiry* 38, 167–178.
- DE BO, Leonard-Lodewijk. 1892. *Westvlaamsch idioticon*. (re-edited by Joseph Samyn). Gent.
- DEBRABANDERE, Frans. 1999. *Kortrijks woordenboek*. Kortrijk: Leiegouw/Brugge: Van de Wiele.
- DESNERCK, Roland. 1972. *Oostends woordenboek*. Handzame.
- FISCHER, Kerstin. (ed). 2006. *Approaches to discourse particles*. Amsterdam: Elsevier.
- GARZONIO, Jacopo. 2004. Interrogative types and left periphery: some data from the Fiorentino dialect, eds. Barbara Patruno & Chiara Polo. *Quaderni di Lavoro dell'ASIS* 4, 1–19. (electronic journal: <http://assis-cnr.unipd.it.html>, issn 1826-8242).
- GOBBO, del Francesca. & POLETTI, Cecilia. 2008. A typology of sentential particles. Paper presented at *Giornata di Dialettologia*, Università di Padua, 20 June 2008.
- GROHMANN, Kleanthes. 2003. *Prolific domains: on the anti-locality of movement dependencies*. Amsterdam: Benjamins.

- HAEGEMAN, Liliane. 1984. Interjections and phrase structure. *Linguistics* 22, 41–49.
- HAEGEMAN, Liliane. 1993. The interpretation of the particle *da* in West Flemish. *Lingua* 90, 111–128.
- HAEGEMAN, Liliane. 1996. Verb Second, the split CP and initial null subjects in early Dutch finite clauses. *Geneva Generative Papers* 4, 133–175.
- HAEGEMAN, Liliane. 2007. Subject omission in present-day written English. On the theoretical relevance of peripheral data. *Rivista di Grammatica Generativa* 32, 91–124.
- HILL, Virginia. 2006. Stylistic inversion in Romanian. *Studia Linguistica* 60, 156–180.
- HILL, Virginia. 2007a. Romanian adverbs and the pragmatic field. *The Linguistic Review* 24, 61–86.
- HILL, Virginia. 2007b. Vocatives and the pragmatics-syntax interface. *Lingua* 117, 2077–2105.
- HILL, Virginia. 2009. Messengers at the pragmatics-syntax interface: the pragmatic role markers in vocatives. Paper presented at the Interfaces 2 conference: University of Kent (Canterbury), May 5–7.
- KIRSNER, Robert & HEUVEN, Vincent van. 1996. Boundary tones and the semantics of the Dutch particles *hè*, *hoor*, *zeg* and *joh*. *Linguistics in the Netherlands 1996*, eds. Crit Cremers & Marcel den Dikken, 133–146. Amsterdam: Benjamins.
- KLOOTS, Hanne. 2007. “Allee, wat was het weer?” Het tussenwerpsel *allee* in spontaan gesproken Standaardnederlands. *Over Taal* 46, 1: 17–19.
- KRATZER, Angelika. 1999. Beyond ‘Oops’ and ‘Ouch’. How descriptive and expressive meaning interact. Paper presented at the Cornell Conference on Theories of Context Dependency, 26 March 1999.
- MORO, Andrea. 2003. Notes on Vocative Case: a case study in clause structure. *Romance Languages and Linguistic Theory 2001*, eds. Josep Quer, Jan Schroten, Mauro Scoretti, Petra Sleeman & Els Verheugd, 247–261. Amsterdam: Benjamins.
- MUNARO, Nicola. 2006. Looking for the atoms of the left periphery: on the interface legibility of interjections and particles. Presented at *Interface Legibility at the Edge*, Bucharest, 25–27 June 2006.
- <http://www.er.uqam.ca/nobel/asymet/conferences/2006/Munaro.pdf>

- MUNARO, Nicola. 2010. On the edge-feature of particles, interjections, and short answers. *Edges, heads and projections. Interface properties*, eds. Anna-Maria di Sciullo & Virginia Hill, 67–86. Amsterdam: Benjamins.
- MUNARO, Nicola & POLETTI, Cecilia. 2003. Ways of clause typing. *Rivista di Grammatica Generativa* 27, 87–105.
- MUNARO, Nicola. & POLETTI, Cecilia. 2009. Sentential particles and clausal typing in Venetan dialects. *Dislocated elements in discourse*, eds. Benjamin Shaer, Philippa Cook, Werner Frey & Claudia Maienborn, 173–199. New York & London: Routledge.
- PENELLO, Nicoletta & CHINELLATO, Paolo. 2008a. Le dinamiche della distribuzione di *ciò* in Veneto. Breve saggio di microvariazione. *L'Italia dei dialetti*, Proceedings of the Dialectology Meeting of Sappada/Plodn – (2007), ed. Gianna Marcato, 111–118. Padova: Unipress.
- PENELLO, Nicoletta & CHINELLATO, Paolo. 2008b. On the distribution of the particle *ciò* in Veneto dialects. Talk presented at the Workshop *Looking for Particles*, Venice, 4 February 2008.
- POGGI, Isabella. 1995. Le interiezioni. *Grande grammatica italiana di consultazione* (vol. 3), eds. Lorenzo Renzi, Giampaolo Salvi & Anna Cardinaletti, 403–425. Bologna: Il Mulino.
- PORTNER, Paul. 2004a. Vocatives, topics and imperatives. Paper presented at the IMS Workshop on Information Structure, Bad Teinach.
- PORTNER, Paul. 2004b. Instructions for interpretation as separate performatives. Ms. Georgetown University.
- ROSS, John R. 1970. On declarative sentences. *Readings in English Transformational Grammar*, eds. Roderick A. Jacobs & Paul S. Rosenbaum, 222–272. Waltham, MA: Ginn & Co.
- RYCKEBOER, Hugo. 1986. Het hulpwerkwoord *doen* in replieken. *Vruchten van z'n akker. Opstellen van (oud-)medewerkers en oud-studenten voor Prof. V.F. Vanacker hem aangeboden bij zijn afscheid van de Rijksuniversiteit Gent*, eds. Magda Devos & Johan Taeldeman, 321–337. Gent: Seminarie voor Nederlandse Taalkunde en Vlaamse Dialectologie, Rijksuniversiteit Gent.

- SCHADEN, Gerhard. 2010. Vocatives: a note on addressee-management. *University of Pennsylvania Working Papers in Linguistics* 16 (1/20), 176–185.
- SCHEGLOFF, Emanuel. A. 1968. Sequencing in conversational openings. *American Anthropologist* 70, 1075–1095.
- SCHELFHOUT, Carla, COPPEN, Peter-Arno, OOSTDIJK, Nelleke & SLIK, Frans van der. 2005. Interjections in Dutch: a corpus-based approach. *Neerlandistiek.nl*. 05.05.
- SHIINA, M. 2005. Positioning and functioning of vocatives: casework in historical pragmatics. *The writer's craft. The culture's technology*, eds. Carmen R. Caldas-Coulthard & Michael Toolan 17–48. New York: Rodopi.
- SPEAS, Margaret. 2004. Evidentiality, logophoricity and the syntactic representation of pragmatic features. *Lingua* 114, 255–277.
- SPEAS, Margaret & TENNY, Carol. 2003. Configurational properties of point of view roles. *Asymmetry in grammar*, ed. Anna-Maria di Sciullo, 315–344. Amsterdam: Benjamins.
- TENNY, Carol. 2006. Evidentiality, experience and the syntax of sentience. *Journal of East Asian Linguistics* 15, 245–288.
- WOUDEN, Ton van der. 2002. Partikels: naar een partikelwoordenboek van het Nederlands. *Nederlandse Taalkunde* 7, 2–42.
- WOUDEN, Ton van der. 2009. *Ik zou wel eens willen weten waar dat woord staat trouwens*. Aantekeningen over zinsfinale bijwoorden. Paper presented at the TINdag, 8 February 2009.
- ZWICKY, Arnold. 1974. Hey, what's your name! *Papers from the Tenth Regional Meeting of the Chicago Linguistics Society*, eds. Michael W. La Galy, Robert A. Fox & Anthony Bruck, 787–801. Chicago: Chicago Linguistics Society.

Liliane Haegeman
Ghent University
Linguistics department (English)
Blandijnberg 2
B-9000 Ghent
Belgium
liliane.haegeman@UGent.be