

WIRELESS SHADOW NETWORK SETUP THROUGH THE MEHROM MICROMOBILITY PROTOCOL

Liesbeth Peters*, Filip De Turck*, Ingrid Moerman, Bart Dhoedt, Piet Demeester
 Department of Information Technology (INTEC), Ghent University - IBBT - IMEC
 Gaston Crommenlaan 8 bus 201, B-9050 Gent, Belgium

{Liesbeth.Peters, Filip.DeTurck, Ingrid.Moerman, Bart.Dhoedt, Piet.Demeester}@intec.UGent.be

ABSTRACT

Due to natural disasters or intentional attacks, large parts of our telecommunication network can be destroyed. The setup of a wireless shadow network can restore the damaged network connectivity. This paper investigates the need for a network layer solution to integrate such a wireless shadow network with the wired network. It presents the combination of the micromobility protocols MEHROM and Mobile IP Regional Registration as an efficient solution to support terminal mobility. The proposed solution is evaluated in terms of control overhead, required storage and calculation capacity, and functional complexity.

I. INTRODUCTION

Nowadays, people more and more rely on the presence of an efficiently working telecommunication network for every day activities both at home and at work. Natural disasters, such as hurricane Katrina on August 29, 2005 along the Central Gulf Coast, or intentional attacks, such as the attack on September 11, 2001 in New York, painfully illustrated that large parts of the network can be destroyed. This leads to a major loss in connectivity because the damage to the network can not be taken care of by the existing resilience schemes, developed to recover the network after the failure of a few network entities. While the setup of a new, wired telecommunication network can take several days or even weeks, connectivity is already essential within the first hours after the disaster, e.g. to coordinate rescue operations: firemen need to communicate with each other, doctors need to consult medical information about the victims from the hospital data base, engineers need to report to the coordination center about the extent of the disaster, etc.

A. Related Work

In order to quickly repair the network connectivity for mobile terminals, such as handhelds and laptops, antennas can be deployed on trucks or on top of non-destroyed buildings. After the 9/11 attack and hurricane Katrina, Cells On Wheels (COWs) were used to restore the network connectivity in the destroyed areas and to boost the capacity in the surrounding areas, to which people were evacuated [1]. Although some COWs may use microwave transmission to reach a COW with a wired connection, mostly, each COW simply plugs in to the

wired phone network. In addition, the COWs offer cellular services to mobile phones, but are not equipped for WiFi, used by laptops and PDAs.

One approach to obtain a better cooperation among the antennas in the destroyed area, is to consider the combination of these antennas as a wireless mesh network (WMN) [2]. The mobile terminals are characterized by high mobility and severe power limitations, while the antennas that form the meshed backbone exhibit minimal mobility and almost no constraint on power consumption. Currently, a lot of Layer 2 efforts are going on. The IEEE 802.11s Task Group has just merged the SEEMesh and Wi-Mesh Alliance proposals into a single proposal for standardization. Also other IEEE Working Groups, like 802.15, 802.16 and 802.20, are currently working on the support of WMNs. On Layer 3, the design of routing protocols for WMNs is still an active research area. Although routing protocols developed for ad hoc networks can be applied to WMNs as well, a routing protocol for WMNs should aim on improving scalability while taking the specific requirements of mobility and power efficiency into account. However, in the WMN solution, the mobile terminals are an active part of the network because they act as both terminal and router for other devices. This is unwanted, as these mobile terminals are extremely power limited.

Another approach is the deployment of a wireless shadow network [3], as illustrated in Fig. 1. Here, antennas, also called nodes, are located on circles and the antennas on a given circle are equidistant. The nodes on the outer circle are antennas with a connection to the wired network. In this paper, the term an-

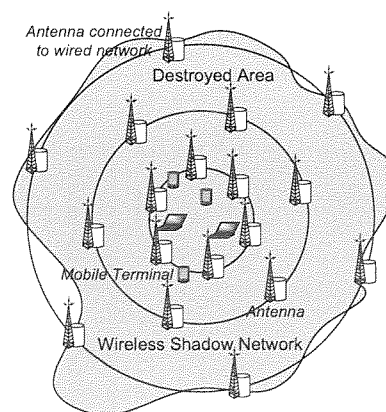

Figure 1: Example of a wireless shadow network.

*L. Peters and F. De Turck are Research Assistant and Postdoctoral Researcher of the Fund for Scientific Research - Flanders (F.W.O.-V., Belgium), respectively.

tenna refers to a node with one or more wireless interfaces and with additional routing capabilities. An important difference with a WMN is that the mobile terminals do not act as router and that the antennas are placed on fixed positions. [3] presents a solution requiring antennas with very low complexity. All antennas on the same circle listen on one frequency band and simply retransmit received signals on another frequency band. In order to avoid interference, communication in the uplink direction takes place in other frequency bands than the downlink direction. However, several routing issues remain. When a data packet from a mobile sender is 'broadcasted' towards the wired network via multiple circles, several nodes on the outer circle may pick up this packet. If all these nodes would forward the packet towards the destination, this results in a lot of unnecessary data load in the wired network. For a mobile receiver, the problem is even more important. At least one antenna on the inner circle that can reach the receiver must receive the data packets. Therefore, the wired network must know which node on the outer circle needs to start 'broadcasting' the information in the shadow network.

B. Assumptions and Objectives

In this paper, we aim to provide a Layer 3 solution for the wireless shadow network. Therefore, we assume a wireless shadow network with n circles $C_i, i = 1 \dots n$, in the destroyed area, in addition to the outer circle C_{n+1} . Furthermore, we assume N omnidirectional antennas on each circle. Possible Layer 2 protocols for a wireless shadow network are IEEE 802.11 [4] (WiFi) or IEEE 802.16 [5] (WiMax), requiring bidirectional links. Therefore, we will use one frequency band f_0 for the communication between the mobile terminals and the antennas on C_1 , and n frequency bands f_i for the communication between C_i and $C_{i+1}, i = 1 \dots n$. The coverage range d_{COV} of the antennas limits the maximum allowed distance between two circles. For reasons of robustness, we assume that for a given d_{COV} , at least two antennas on C_{i+1} are situated within the coverage range of a particular antenna on C_i and at least two antennas on C_i are situated within the coverage range of a particular sender on C_{i+1} .

Severe requirements must be fulfilled. First, the functionality of the antennas should be as simple as possible, as this lowers the setup time and the financial cost. Second, no extra requirements should be imposed on the functionality of the non-destroyed wired network and the mobile terminals. Third, from a network layer point of view, the wireless shadow network should provide reliable communication between the mobile terminals and the wired network and among the mobile hosts. Also, the connection should be supported during terminal mobility.

We present the use of the micromobility protocol MEHROM (Micromobility support with Efficient Handoff and Route Optimization Mechanisms) [6] as routing protocol to provide network connectivity for the mobile terminals and to support communication between mobile hosts. In order to integrate the wireless shadow network with the wired network, MEHROM is combined with Mobile IP Regional Registration (Mobile IP-RR) [7]. The rest of this paper is structured as follows. Sect. II.

investigates the advertising of Layer 3 topology information. Next, Sect. III. presents the use of MEHROM and Mobile IP-RR as network layer solution. Sect. IV. investigates the robustness of this solution against an antenna failure. In Sect. V., the performance of our solution is evaluated. The final Sect. VI. contains our concluding remarks.

II. WIRELESS SHADOW NETWORK TOPOLOGY

MEHROM makes use of (Layer 3) topology information. In a wired access network, for which MEHROM was initially developed, this information is gathered and calculated by OSPF (Open Shortest Path First). However, the use of such a complex routing protocol is not suitable for a wireless shadow network. Therefore, the topology information is obtained as explained in this section.

Tree Topology Every antenna transmits Agent Advertisements, also called beacons, on its downlink interface. These beacons have three important functions. First, based upon these beacons, e.g. their signal strength, a node on C_i selects an uplink node on C_{i+1} for uplink data and control traffic. This results in the setup of a wireless tree topology, as illustrated in Fig. 2. Second, based upon the announced care-of addresses in the received beacons, a mobile host can distinguish several kinds of mobility (see Sect. III.). Third, the beacons of all but the outer circle, i.e. $C_i, i = 1 \dots n$, contain a U-bit to indicate a change in selected uplink node (see Sect. IV.). These beacons also contain a Hop-field, indicating the number of hops to the outer circle.

The format of the Agent Advertisements is illustrated by Fig. 3. In detail, a node on the outer circle C_{n+1} transmits Agent Advertisements as defined for Mobile IP-RR [7]: the first care-of address in the Mobility Agent Advertisement Extension is the Foreign Agent (node on C_{n+1}), the second is the Gateway Foreign Agent (agent in the wired network). The beacons of a node on C_n contain the same care-of addresses as the beacons of the selected uplink node on C_{n+1} . In addition, the node inserts itself as the first care-of address. Finally, nodes on the inner circles $C_i, i = 1 \dots n - 1$, use the same care-of addresses as the selected uplink node for its own beacons, but replaces the first care-of address with its own. As a result, an Agent Advertisement contains at maximum, irrespective of the number of circles, three care-of addresses.

Additional Mesh Links The nodes on the inner circle C_1 send Router Advertisements [8] on frequency f_1 , i.e. without a Mobility Agent Advertisement Extension. Any other antenna on the same circle C_1 , receiving these Router Advertisements, adds in its routing table entries with the IP addresses of its neighbors. The absence of the Mobility Agent Advertisement Extension avoids confusion with the Agent Advertisements, sent by the nodes on C_2 in the same frequency band. As a result, mesh links are added to the tree topology, also indicated in Fig. 2. The format of such a Router Advertisements is depicted in Fig. 3. MEHROM can take advantage of these mesh links to deliver a better handoff performance to the mobile hosts [6]. In addition, mesh links can also be used for data

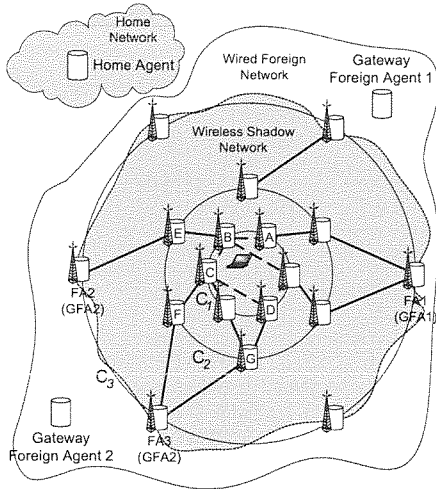

Figure 2: Example of a wireless shadow network with a basic tree topology (full lines) and additional mesh links (dashed lines), integrated with the wired network.

Mobility Agent Advertisement Extension
Node on outer circle C_{n+1} on f_n :

Type	Length	Sequence Number
Registration Lifetime	R B H F M G V T S I	resv.
Care-of Address (Foreign Agent)		
Care-of Address (Gateway Foreign Agent)		

Node on other circles C_i on f_{i-1} , $i = 1...n$:

Type	Length	Sequence Number
Registration Lifetime	R B H F M G V T S I U _{opt}	Hop
Care-of Address (node on C_i)		
Care-of Address (Foreign Agent)		
Care-of Address (Gateway Foreign Agent)		

Router Advertisement Message
Node on inner circle C_i on f_i :

Type	Code	Checksum
Num Addr	Addr Entry Size	Lifetime
Router Address [1]		
Preference Level [1]		
...		

32 bit

Figure 3: Format of the Mobility Agent Advertisement Extensions in the Agent Advertisements and format of the Router Advertisements of the nodes on C_1 .

traffic between mobile hosts (see Sect. III. Traffic between Mobile Hosts).

III. MEHROM MICROMOBILITY PROTOCOL

A. Mobility Support

A mobile host may receive Agent Advertisements from several nodes on C_1 . Based on the information in these beacons, the mobile host can distinguish different types of mobility. The exchange of the handoff control messages is illustrated in Fig. 4.

Home Registration (Fig. 4.A) When the Gateway Foreign Agent (GFA) in the received beacon differs from its current one, the mobile host informs its Home Agent (HA) by a home registration. Therefore, the mobile host sends a home registration request to the Foreign Agent (FA), also announced by the beacon, and with itself as source address. The antennas simply forward this request using their selected uplink node and make an entry in their routing cache for the mobile host's downlink data traffic. Once the request arrives in the FA, the request is processed like a Mobile IP home registration [7]. As a result, the HA maps the mobile host's home address to the new GFA and the GFA maps the mobile host's home address to the correct FA.

Regional Registration (Fig. 4.B) If the GFA is the same but the FA differs, only the mapping in the GFA is updated by a regional registration. This time, the mobile host sends a regional registration request to the new FA. Again, the antennas forward the request using the selected uplink nodes and store an entry for the mobile host to route downlink traffic. Once the request arrives in the FA, the request is processed like a Mobile IP regional registration [7].

Local Mobility Support by MEHROM (Fig. 4.C) If only the node on C_1 changes, this is supported by MEHROM. In this case, a local registration request is sent, with the new antenna on C_1 as destination. This request also contains the IP address of the previous antenna on C_1 in a Previous Foreign Agent Notification Extension (PFANE) [9]. The new antenna adds an entry for the mobile host in its routing cache and starts the first phase of the MEHROM handoff scheme.

Phase 1: Fast Handoff: A route update message is sent by the new antenna towards the previous one in a hop-by-hop way. During this phase, an antenna that receives this message can detect itself whether it has the function of cross-over node: if the routing table of the node contains an entry for the mobile host, pointing to a node different from the one that forwarded the route update message, the receiving node is the cross-over node. This node will not forward the route update message further. In addition, this cross-over node can detect whether the resulting new path between the FA and the new antenna on C_1 is optimal, i.e. if it is a path with a minimum number of hops. Therefore, the route update message contains a cross-over-distance parameter. This parameter initially has a value of 1 and is incremented by 1 every time the route update message is forwarded. If the sum of the cross-over-distance parameter and the number of hops between the cross-over node and the outer circle equals n , the new path is optimal. The cross-over node sends a delete message in a hop-by-hop way to the old antenna on C_1 and an acknowledgment to the new one. This first phase is concluded by sending a local registration reply to the mobile host.

Phase 2: Route Optimization: In the case of the tree topology of Fig. 2, the new path is optimal. This is indicated by the acknowledgment and the second phase is not started. However, in the case of the meshed topology of Fig. 2, the acknowledgment may indicate that the new path is suboptimal and the second

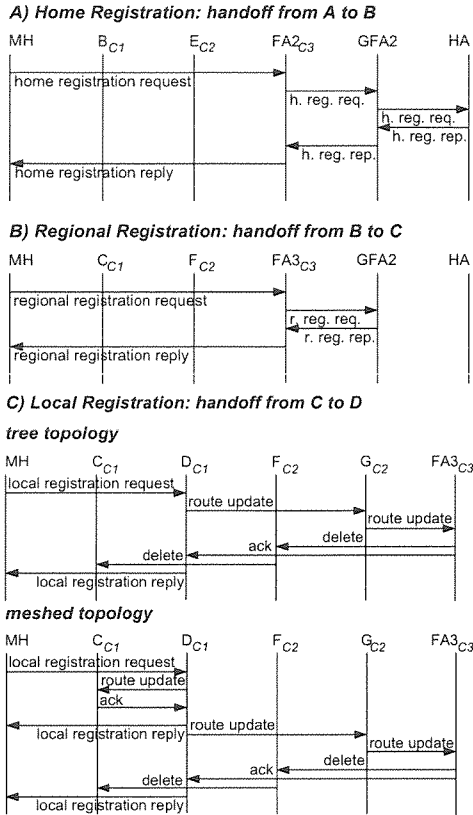

Figure 4: Exchange of handoff control messages during a home, regional and local registration.

phase is started. The new antenna on C_1 sends a new route update message, this time with the FA as destination address. This route update message may find a new cross-over node or finally arrive in the FA. This time an acknowledgment, indicating that the new path is optimal, is sent back to the new AR.

B. Data Traffic Support

Uplink Traffic To send a data packet to a fixed terminal in the wired network, the mobile host sends the packet to the selected antenna on C_1 . The data packet is forwarded by the antennas, each simply using its selected uplink node, and finally the packet arrives in an antenna on the outer circle. From then on, the data packet is forwarded further based on its destination IP address.

Downlink Traffic The HA intercepts all data packets for the mobile host and tunnels them to the GFA, stored in its mapping table. This GFA decapsulates the data packets and reencapsulates them for tunnelling to the current FA, i.e. node on C_{n+1} . Finally, this FA decapsulates them and sends out the data packet on its wireless interface. Only the antenna on C_n with an entry for the mobile host retransmits this data packet on its downlink interface. Finally, the antenna on C_1 with an entry for the mobile host retransmits the data packet. In the

wireless shadow network, the routing is based on the mobile host's home address.

Traffic between Mobile Hosts So far, data packets sent between two mobile terminals, are first forwarded to the home network of the destination and then routed back towards the wireless shadow network. This high end-to-end delay can be lowered if an antenna first checks whether it has an entry for the destination before forwarding the packet to its uplink node. If an entry is available, the routing of data packets can be restricted to the shadow network.

In the most efficient situation, a mesh link can be used, realizing a very short path between two mobile hosts. In order to use these mesh links, we define a new extension to the Router Advertisements: after the receipt of a registration reply or a MEHROM acknowledgment, an antenna on C_1 can announce which mobile hosts are located in its coverage range by the transmission of an extra Router Advertisement. In order to make this a reliable solution, the presence of invalid entries in the routing tables must be avoided. MEHROM itself explicitly deletes old entries after handover by using delete messages. However, after a home or regional registration, old entries may still exist between the old FA and the previous antenna. These invalid entries can be explicitly deleted as follows: each node on C_1 that receives a Router Advertisement announcing a mobile host and that has an old entry for that mobile host, sends a message to its uplink node to announce that the entry is outdated. An antenna that receives such a message and that has an old entry, deletes that old entry and forwards the message to its uplink node.

IV. UPLINK CHANGES

Although the position of the antennas is assumed to be fixed, an antenna may select another uplink node due to e.g. a node failure or a better beacon signal strength.

When a node on C_n selects another node on the outer circle C_{n+1} , this results in the advertisement of a new FA or even a new GFA. Finally, the beacons sent out by the nodes on C_1 announce these changes. A mobile host interprets these changes in the same way as when it moves to a new antenna and reacts by sending a home or regional registration request.

However, when a node on C_i chooses a new node on $C_{i+1}, i = 1 \dots n - 1$, this is not necessarily reflected in the beacons sent out by the nodes on C_1 . Therefore, when an antenna selects a new uplink node, it sets the U-bit in its beacons to 1. Nodes that receive beacons with the U-bit on, also set this bit to 1. It is important that the setup of a new path after an uplink change is triggered by the mobile host to avoid router inconsistencies, resulting from the simultaneous setup caused by an uplink change and caused by handoff [10]. Therefore, a mobile host sends a local registration request, every time it receives a beacon from its selected antenna, but only if it is not performing handoff soon. After an uplink change, the antenna sends a route update message to the FA to setup a new path.

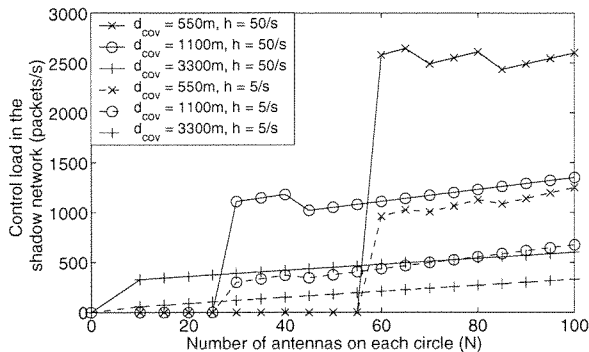

Figure 5: Control load in the wireless shadow network.

V. PERFORMANCE

Control Load A first part of the control load in a wireless shadow network consists of the Agent Advertisements, and the Router Advertisements. Note that at the end of each handoff, the involved antenna on C_1 sends an extra Router Advertisement. The resulting load is expressed by $a(n+2)N + h$. Here, a is the rate of Advertisement transmissions per node and h indicates the handoff rate in the network. A second part is caused during the home or regional registrations. When the delete messages are also taken into account, the resulting load is given by $h_1(2(n+1) + n)$ for the home registrations and by $h_2(2(n+1) + n)$ for the regional registrations. A last part is caused during the local registrations. In this case, the amount of control packets depends on the location of the cross-over node. In the worst case, this is the FA. The maximum amount of control load is given by $h_3(2+3n)$ for the tree topology and by $h_3(4+3n)$ for the meshed topology. Here, $h_1+h_2+h_3 = h$ and $h_1 < h_2 < h_3$. As an example, for an area with a radius of 5km, the minimum required number of circles n for complete coverage can be calculated for different values of d_{cov} and N ($n = 0$ indicates that no solution exists). Fig. 5 depicts the resulting control load ($a = 1/s$). For a given value of h , the control load is mainly influenced by the number of circles.

Stored Information and Path Calculations Each antenna in the wireless shadow network stores information about the selected uplink node, the number of hops to the outer circle C_{n+1} and the occurrence of recent uplink changes. An antenna on the inner circle C_1 may store extra entries for its neighbors and the mobile hosts located in the coverage range of these neighbors. As the nodes do not have an entry for every other node of the shadow network, the amount of stored information is very limited and mainly influenced by the number of mobile hosts.

To support mobility, no path calculations are needed, which is a great advantage. Instead, when an antenna forwards a registration request for a mobile host, it installs an entry with the next hop towards that mobile host. Also MEHROM simply updates the entries in the routing caches of the antennas.

Functional Complexity The functionality of the mobile hosts is kept as simple as possible. Based upon the beacons, the

mobile host can make a distinction between a home, regional and local registration in a way, very similar to Mobile IP-RR. The functionality in the wired network is limited to Mobile IP-RR and is concentrated in specific nodes, like the GFAs and FAs. The antennas of the wireless shadow network itself run MEHROM.

VI. CONCLUSIONS

This paper investigated the use of a wireless shadow network and its need for a network layer solution to restore network connectivity in the case of a severe network outage. The use of MEHROM in combination with Mobile IP-RR is presented to integrate the shadow network with the wired network. A tree topology is formed by the use of Agent Advertisements, while Router Advertisements can be used to add mesh links between the antennas on the inner circle. MEHROM takes advantage of these mesh links to improve the handoff performance and to restrict the routing path between two mobile hosts to the shadow network. The presented solution is robust against antenna failures. The performance evaluation pointed out that the control load is mainly influenced by the number of circles. No path calculations are performed and the required storage capacity is mainly influenced by the number of mobile nodes. The only functionality required from the mobile hosts is the capability to distinguish the different kinds of mobility and to send appropriate registration requests.

ACKNOWLEDGMENTS

Part of this research is funded by the Belgian Science Policy Office through the IAP (phase V) Contract No. IAPV/11, by the IWT in Flanders through the GBOU Contract 20152, and by the CELTIC-WISQUAS Project CP2-035.

REFERENCES

- [1] Cells On Wheels, http://www.e-n-g.com/mobile_cell_sites/cell_sites/
- [2] I.F. Akyildiz, X. Wang, W. Wang, "Wireless mesh networks: a survey", *Computer Networks, Elsevier*, 2005, vol. 47, pp. 445-487.
- [3] F. De Turck, A.A. Lazar, "Modeling wireless shadow networks", *7th ACM International Symposium on Modeling, Analysis and Simulation of Wireless and Mobile systems (MSWiM'04)*, Italy, pp. 195-202.
- [4] "Wireless LAN Medium Access Control (MAC) and Physical Layer (PHY) Specifications", *IEEE Std. 802.11-99 Part 11*, 1999.
- [5] "Air Interface for Fixed Broadband Wireless Access Systems", *IEEE Std. 802.16-2004*, 2004.
- [6] L. Peters, I. Moerman, B. Dhoedt, P. Demeester, "MEHROM: Micromobility support with efficient handoff and route optimization mechanisms", *16th ITC Specialist Seminar on Performance Evaluation of Wireless and Mobile Systems*, 2004, Belgium, pp. 269-278.
- [7] E. Gustafsson, A. Jonsson, C. Perkins, "Mobile IPv4 regional registration", *draft-ietf-mip4-reg-tunnel-01.txt, work in progress*, Nov. 2005.
- [8] S. Deering, Ed., "ICMP router discovery messages", *IETF RFC 1256*, September 1991.
- [9] C. Perkins, D. Johnson, "Route optimization in Mobile IP", *draft-ietf-mobileip-optim-11.txt, work in progress*, September 2001.
- [10] L. Peters, I. Moerman, B. Dhoedt, P. Demeester, "Support of path changes with resource reservations for mobile hosts in IP-based access networks", *IEEE Global Communications Conference (GLOBECOM'05)*, USA, vol. 6, pp. 3559-3563.

pimrc'06

HELSINKI
www.pimrc2006.org

2006 IEEE 17TH INTERNATIONAL SYMPOSIUM ON PERSONAL
INDOOR AND MOBILE RADIO COMMUNICATIONS

11-14 SEPTEMBER 2006 | FINLANDIA HALL | HELSINKI, FINLAND

proceedings

© 2006 IEEE

IEEE Catalog Number: 06TH8881C
ISBN: 1-4244-0330-8
Library of Congress: 2006922877