

Novel optical architectures for LED-based LCOS projectors

Hüseyin Murat

Supervisor: Herbert De Smet

Abstract: In this work we have designed a novel optical architecture for LED-based LCOS projectors. First we have investigated the available LEDs and characterized them. Further the LED illumination engine with the custom collection system is designed, simulated and manufactured to use them in our novel architecture that is based on two LCOS light valves. This architecture is firstly simulated and optimized by using ray-tracing software ZEMAX. After testing the several parts of this architecture experimentally, we have built a LED projector demonstrator. The several aspects that is evolved to optimally and efficiently use the available light flux will be discussed.

Keywords: LED, LCOS, projector, gradually tapered light pipe

I. INTRODUCTION

High brightness light emitting diodes (HBLEDs) become a serious alternative for ultrahigh performance lamps in projection displays. Their optical power has consistently increased since their invention, and they are becoming much more efficient. They have numerous advantages [1] compared to these traditional light sources. They are compact and robust, exhibit a larger color gamut and a longer lifetime, the supply voltage is lower, they can switch on/off very rapidly, have a high dimming ratio that can be used to improve the contrast, etc. A disadvantage is still the significantly lower optical power per unit étendue (luminance). LEDs are totally different from the classical light sources (shape, radiation pattern, wavelengths, driving requirements, etc). The illumination engine and the optical architecture of the projector should be adapted to the requirements of this light source. In this paper we will describe the work that we have done in this scope.

Figure 1 shows a schematically projector architecture with the most important basic blocks. The reflector collects the light into the integrator pipe that will reshape and homogenize the spot to illuminate the LCOS panel uniformly. The exit of the pipe will be imaged to the light valve that will modulate (on polarisation base) the incoming beam to create an image. That image will be projected to the screen by the projection lens.

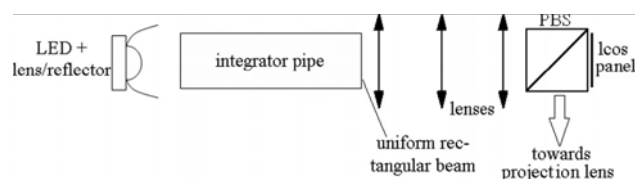

Figure 1: A monochrome LCOS projector based on an LED

II. AVAILABLE LEDs AND COLLECTION COMPONENTS

At the beginning of this research we have investigate the available HBLEDs. The interesting LEDs are that with a high luminance (lumens per étendue) and an étendue that matches the system étendue. We found several companies that produces HBLEDs and the most interesting companies were LUMILEDS, OSRAM and LUMINUS with respectively LUXEON, OSTAR and Phlatlight LEDs. During the years of research we have followed up these LEDs and they have shown an appreciable advance. Phlatlight LEDs were unobtainable for us, so we have only purchased several types of LUXEON and OSTAR LEDs and characterized them (geometrically, optically and electrically). At this moment the most powerfull and suited LED for our projection system is the OSTARs and we will use them for our projector design.

Another research topic was the available collection optics. After studying and testing these components we have observed that the available collection optics have a low efficiency and are not suited for our application. Therefore we have designed custom made collectors. In the following paragraph we will discuss the several designed types.

III. DESIGN OF COLLECTION COMPONENTS FOR LED LIGHT

A. Elliptical Reflector and Parabolic Reflector

To capture the light from the LEDs efficiently, we have designed and optimized custom parabolic and elliptical reflectors by using the non-sequential ray tracing program ZEMAX. Dependent of the used LED, the shape and the efficiency of the reflector is different. If the source (LED) étendue is smaller as the system étendue (size light valve * f-number projection lens), we can combine multiple high luminance LEDs/reflectors to fill the system étendue. If we compare both reflectors, we can conclude that the elliptical reflector approach is more efficient than the parabolic approach, but it is also more voluminous. We have described this work in detail in a paper [1] where we also discuss the obtained results. Because of the difficulty to fabricate them we have only done simulations.

B. Gradually Tapered Light Pipe (GTLP)

Another collector approach is the gradually tapered light pipe. GTLP is a component that acts as a collector and an integrator and at the same time adapts the radiation pattern into the desired acceptance angle. The light from the LED will be directly and entirely coupled into the GTLP and will

propagate through the pipe. This concept is also simulated and optimized with ZEMAX. Because of its high collection efficiency (81%) and the good uniformity (ANSI standard: +2.2%/-5.8%) we have decided to fabricate this collector. The fabrication (milling and polishing) is also done by ourselves. The measured efficiency is also promising. The work [1] about this component is also published in a journal where the results can be consulted in more detail.

IV. COMPACT 3-LCOS ARCHITECTURE

LED-based projectors have numerous advantages compared to traditional projectors, but have significantly lower optical power per unit of étendue. Therefore, we have build a compact, portable projector where we use this moderate output in a most efficient way. The architecture is a 3-LCOS system, one per color, where we use one LED-GTLP per color. The three colors will be combined by an X-cube after modulation and afterwards the created image will be projected on the screen. By using three panels the projected flux will be higher and no color-breakup will appear. This system is compact, simple and efficient. We have a simulated throughput of 24%, with a reasonable uniformity and contrast. In figure 2 is the architecture demonstrated. The several aspects of this architecture and the results are presented [1] in the journal *Displays*.

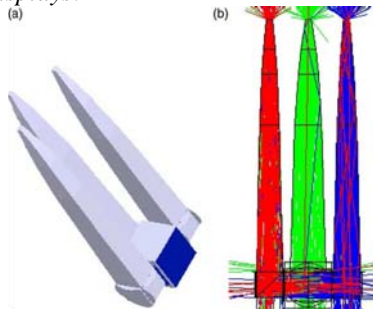

Figure 2: Layout of compact 3-LCOS LED projector
(a) 3D view; (b) front view with light rays

V. 2-LCOS PROJECTOR DEMONSTRATOR

A second architecture that we have realized is a 2-LCOS system [1]. Figure 3 gives the layout of this architecture.

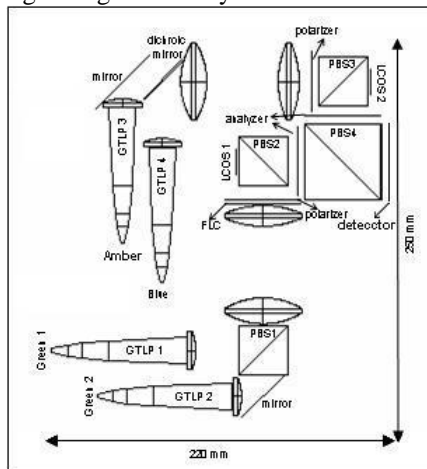

Figure 3: Schematic architecture of the 2-LCOS projector

If we compare the optical power of blue, green and red LEDs, we will observe that the green LED has the weakest power

and will be the limiting color in a color balanced projector that produces for example D65 white color point (6500K). The limitation is so pronounced that the red and blue LEDs have to work at half power to have balanced color or at full power but at half time. That means that we can use one panel for green channel and one panel the half of the time for blue and the other half of the time for red channel, so we can save one LCOS panel. This system is used in our 2-LCOS architecture. To increase the optical power we will pulse red and blue LEDs at a higher peak current to have a higher peak flux. We have also used two alternately pulsed green LEDs to increase also the optical power of the green channel. Combining two green LEDs within the same étendue is not so straightforward. We have developed a special architecture that makes this possible [1] and experimentally measured net gains dependent of the used LEDs and PBS. For this concept is a patented (EP 578 123 A2) demanded.

This architecture is simulated with realistic components and all losses are taken into account. The optical throughput is about 10% and with the new generation OSTAR LEDs we get a color balanced projector that produces 171 lm D65 light output with a high contrast ratio 2500:1 and a good uniformity, within a system étendue lower than 20 mm²sr. In spite of semi color sequential working, the color breakup and crosstalk are expected to be negligible.

Unlike the 3-LCOS system, we have not only done the simulations, but have also effectively built a demonstrator setup. As LCOS panels we have used QXGA imagers from Gemidis. The measured throughput and the projected flux are, as expected, lower as the simulated one. The reason is the lower efficiency of the used components as projection lens, reflectivity screen, PBS, LEDs, etc. but also the fact that the frame cannot be written instantly to the imagers. By these means we can only pulse red and blue with 25% duty cycle and will loss 50% of the simulated flux.

VI. CONCLUSION

We have shown that LEDs can be used for projectors. We have done the necessary adaptations in the architecture and demonstrated successfully a LED based LCOS projector.

ACKNOWLEDGEMENTS

This work was partially funded by the Fonds voor Wetenschappelijk Onderzoek-Vlaanderen (project name is *Nieuwe optische architecturen voor LCOS projectoren*) and the Instituut voor de aanmoediging van innovatie door Wetenschap en Technologie in Vlaanderen (project name is *Compact high-quality LED projection systems*).

REFERENCES

- [1] H Murat, H De Smet, D Cuypers, Y Meuret, H Thienpont, M Vervaeke, and L Desmet, "Increased lumens per étendue by combining pulsed light-emitting diodes," *Opt Eng* **45**, No. 3, 034002 (March 2006).
- [2] H Murat, D Cuypers, H De Smet. "Design of new collection systems for multi LED light engines", *Proceedings of SPIE, Photonics in Multimedia*. Vol. 6196, 619604 (2006)
- [3] H Murat, A Gielen, H De Smet, "Gradually tapered light pipes for illumination of LED projectors", *JSID*, Vol. 15, 519-526, 2007
- [4] H Murat, H De Smet, D Cuypers. "Compact LED projector with tapered light pipes for moderate light output applications", *Displays*, Vol. 27, 117-123 (2006)
- [5] H Murat, D Cuypers, H De Smet, Y Meuret, B Van Giel, L Bogaert, H Thienpont, "Two LCOS projector with efficient LED illumination engine", *Opt Eng*, in progress (2007)