

# DISCUS: the Distributed Core for Ubiquitous Broadband Access

Marco RUFFINI<sup>1</sup>, David PAYNE<sup>1</sup>, Nick DORAN<sup>2</sup>, Mohand ACHOUCHE<sup>3</sup>, Nick PARSONS<sup>4</sup>, Thomas PFEIFFER<sup>5</sup>, Xin YIN<sup>6</sup>, Harald ROHDE<sup>7</sup>, Marco SCHIANO<sup>8</sup>, Peter OSSIEUR<sup>9</sup>, Barry O'SULLIVAN<sup>10</sup>, Roland WESSÁLY<sup>11</sup>, Lena WOSINSKA<sup>12</sup> and Julio MONTALVO<sup>13</sup>

<sup>1</sup> Trinity College Dublin, College Green, Dublin 2, Ireland

Tel: +353 1 8964336, Email: [marco.ruffini@tcd.ie](mailto:marco.ruffini@tcd.ie)

<sup>2</sup> Aston University, Aston Triangle, Birmingham, B4 7ET, United Kingdom

<sup>3</sup> III-V Lab, Route de Nozay, Marcoussis, 91460, France

<sup>4</sup> Polatis, Cambridge Science Park, Cambridge, CB4 0WN, United Kingdom

<sup>5</sup> Alcatel-Lucent, Lorentzstrasse 10, Stuttgart, 70435, Germany

<sup>6</sup> IMEC, St. Pietersnieuwstraat 41, Ghent, 9000, Belgium

<sup>7</sup> Nokia Siemens Networks, St. Martin Strasse 76, Munchen, 81541, Germany

<sup>8</sup> Telecom Italia, Via Reiss Romoli 274, Torino, 10148, Italy

<sup>9</sup> Tyndall, Dyke Parade, Cork, Ireland

<sup>10</sup> University College Cork, Western Road, Cork, Ireland

<sup>11</sup> atesio, Bundesallee 89, Berlin, 12161, Germany

<sup>12</sup> Royal Institute of Technology KTH, Valhallavaegen 79, Stockholm, 1004, Sweden

<sup>13</sup> Telefónica I+D, Don Ramón de la Cruz 82, Madrid, 28006, Spain

**Abstract:** A new end to end architecture based on Long-Reach Passive Optical Network (LR-PON) with wireless integration, a distributed core built of optical transparency islands and an OpenFlow-based control plane, which is being developed in the EU project DISCUS, is described in this paper. The main technological advances and the network modelling and optimization approach are reported.

**Keywords:** Long Reach Passive Optical Network, Optical Islands, OpenFlow

## 1. Introduction

DISCUS, the “DIStributed Core for Unlimited bandwidth for all Users and Services” is a European FP7 Integrated Project [1] with the objective of designing an economically viable, ubiquitous, high speed Fibre to the Premises (FTTP) based broadband network that is environmentally sustainable and evolvable.

The essential concept of the project is to apply optical technologies through the fixed network eliminating traditional demarcations of metro, regional core and access, and avoiding the digital divide between users regardless of geographic location, thus providing the feature of “principle of equivalence” whereby all network access points have equal bandwidth and service capabilities.

The paper is organized as follows: first, a description of the long reach access architecture is reported in Section 2, describing technology advances in PON systems and the wireless integration approach required to support the DISCUS concept. In Section 3, the DISCUS node architecture is described. The flat optical core architecture interconnecting all the DISCUS nodes is described in Section 4, while Section 5 presents the network planning

methodology used for demonstrating the practical feasibility of the proposed architecture. Finally, Section 6 comprises a summary and the main conclusions.

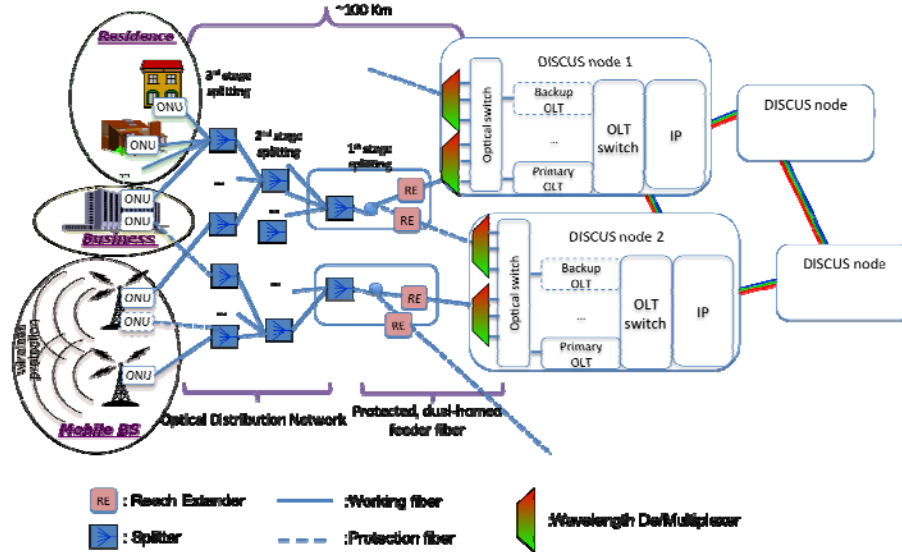

Figure 1: DISCUS reference architecture

## 2. Long-Reach Access Architecture and Optical-Wireless Integration

An access network based on Long Reach Passive Optical Network (LR-PON) is proposed, with a distance between Optical Network Unit (ONU) at user premises and Optical Line Terminal (OLT) at the Central Office (CO) that can be over 100km and could support up to 1024 customers, see Fig. 1.

In order to support the proposed LR-PON access, new physical layer technologies will be required both in the OLT and ONUs. Tuneable lasers based on a multisection Fabry-Perot (FP) with integrated slots is a potentially low-cost solution [2] which, in combination with tuneable filters with polarization diversity and low intrinsic insertion loss based on Silicon Photonics (SiP) technology [3], can achieve the flexibility required for the dynamic wavelength assignment in the LR-PON.

In order to achieve a large differential reach in the LR-PON, similar to the full network reach, burst-mode receiver side electronic dispersion compensation (EDC) with burst-to-burst adaptation of the tap settings is a promising cost-efficient solution [4], as well as coherent technology, using SiP integrated lasers [5] and optical modules.

For a single-carrier 40Gb/s upgrade from 10Gb/s, DISCUS proposes an electrical duobinary modulation of a high-power external cavity laser monolithically integrated with an electro-absorption modulator and booster semiconductor optical amplifier, and a time division multiplexing bit-interleaving concept capable of reducing the power consumption [6].

Regarding optical wireless integration, delays must be kept to low values enough to guarantee adequate functions such as Inter-Cell Interference Coordination (ICIC) or Coordinated Multi-Point (CoMP) transmissions. In a first approach, intra and inter LR-PON physical paths and integration of bandwidth scheduling functions between ONUs and base stations are proposed.

## 3. DISCUS node

The DISCUS node is a core edge node providing the only electronic packet processing interface between PONs and core transmission network, see Fig. 2. Each node has an access side, facing the LR-PONs and a core side, facing the wavelength-switched optical core.

The electronic switching capabilities can be implemented as separate Ethernet and IP layers, as in Fig. 2, or could converge into an OpenFlow/SDN (Software Defined Network) enabled electronic switch.

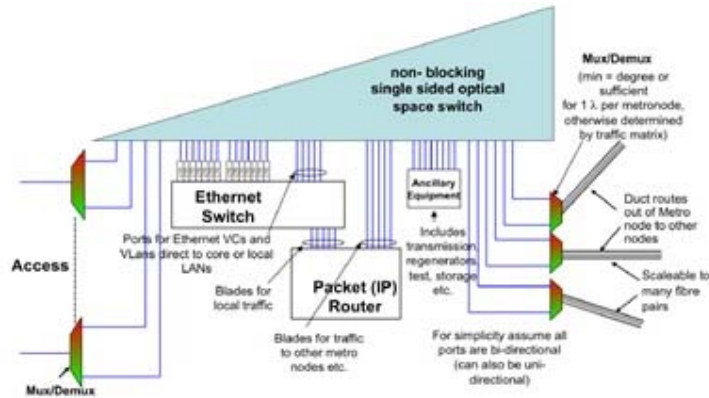

Figure 2: DISCUS node functional scheme

Multi-stage non blocking fibre switch structures that can economically scale to over 10000 ports with low loss (<3dB) allow maximum flexibility to the DISCUS node [7].

An OpenFlow-based node controller allows supervising all dynamic wavelength and sub-wavelength provisioning operations in the node.

#### 4. Flat Optical Core with Optical Islands

The core segment is a flat optical network interconnecting DISCUS nodes through a mesh of wavelength channels. These wavelengths traverse intermediate core nodes without entering the electronic sub-layers. All nodes belonging to the same flat core form a transparent island. Interconnection among transparent islands can be achieved through signal regeneration, or traffic grooming and processing where required.

Multi-gateway and multi-hub hierarchical architectures for inter-island interconnection are being evaluated for optimal island definition. Modulation formats and spectrum allocation must be incorporated in the routing and wavelength assignment (RWA) algorithms, as transmission rates increase above 100 Gb/s towards 400 Gb/s.

Trade-offs such as survivability versus cost/energy efficiency are considered by analysing how and up to which level resiliency should be offered, and also how to maximise the use of restoration strategies and how to replace 1+1 with 1:N protection mechanisms, while maintaining very high levels of network availability.

#### 5. Network Modelling and Optimization

The simulation of deployment scenarios, using realistic data from a number of operators and countries, is being carried out in DISCUS. In a test scenario carried out for the United Kingdom (UK) network, the number of nodes with electronic processing equipment can technically be reduced from about 5600, down to around 75 using LR-PON technologies [8], see Fig. 3.

End to end architecture modelling is being performed by means of building a reference scenario composed of a nation-wide fibre network topology (including today's central office locations), detailed street cabinets and building locations, service and traffic models (static and dynamic), system models for access and core network systems. CAPEX and OPEX models are being developed in order to find the right economical and technological balance between the access and the core network design for any network operator.

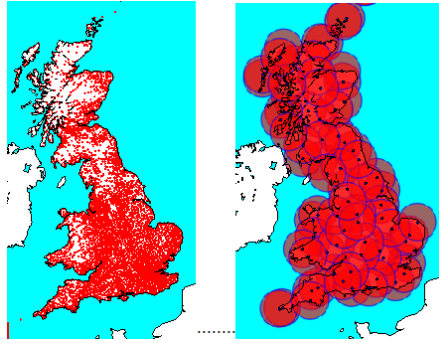

Figure 3: Example of node consolidation of the national UK network using LR-PON, from 5600 local exchanges (left) to about 75 DISCUS nodes (right)

Regarding regulatory aspects, current regulatory policy in Europe is built on the past success of local loop unbundling (LLU) of the copper pair, which focused on competition at the physical layer, which is not an efficient approach neither for FTTP nor for mobile networks.

DISCUS fully dynamic and flexible bandwidth assignment and service provisioning can maximise the economic benefits of enabling full competition at the service layers, if enough regulatory and standardization support is obtained.

## 6. Conclusions

The paper describes an end-to-end architecture based on LR-PON with wireless integration, a distributed core built of optical transparency islands and an OpenFlow-based control plane, which has been proposed in the EU project DISCUS. This end-to-end architecture inherently offers several advantages compared to the existing approaches, such as low energy consumption, high scalability and upgradeability, to mention a few. The central part of the proposed approach is the DISCUS node, whose architecture will provide flexibility and cost efficiency. In summary, the new end to end network design approach is aimed to guarantee a cost-efficient ubiquitous high speed broadband access in order to address the future user demands.

## References

- [1] <http://www.discus-fp7.eu/>
- [2] S. O'Brien, et.al. "Design, characterization, and applications of index-patterned Fabry-Perot Lasers", *IEEE J. Sel. Topics Quantum Electron.*, vol. 17, pp. 1621-1631, Dec. 2011.
- [3] W. Bogaerts et al., "Silicon-on-Insulator Spectral Filters Fabricated With CMOS Technology", *IEEE journal of selected topics in quantum electronics*, vol 16 no 1 , pp33-44, 2010.
- [4] S. Porto, C. Antony, G. Talli, P. Ossieur and P.D. Townsend, "Requirements for adaptive electronic dispersion compensation in burst-mode systems", *Optical Fiber Conference (OFC'2013)*, Paper OTh3B.5, March 2013.
- [5] E. MArchena, T. Creazzo, S. B. Krasulik, P. K. L. Yu, D. Van Orden, J. Y. Spann, C. C. Blivin, J. M. Dallasasse, P. Varangis, R. J. Stone, A. Mizrahi, "Integrated Tunable CMOS Laser for Si Photonics", *OFC 2013*, PDP5C.7
- [6] C. Van Praet, H. Chow, D. Suvakovic, D. Van Veen, A. Dupas, R. Boislaigue, R. Farah, M. Lau, J. Galaro, G. Qua, N. Anthapadmanabhan, G. Torfs, X. Yin, and P. Vetter, "Demonstration of low-power bit-interleaving TDM PON," *Opt. Express* 20, B7-B14, 2012.
- [7] R. Jensen, A. Lord, N. Parsons, "Highly scalable OXC-based contentionless ROADM architecture with reduced network implementation costs", *OFC/NFOEC 2012*.
- [8] M. Ruffini, D. Mehta, B. O'Sullivan, L. Quesada, L. Doyle, D. B. Payne. Deployment case studies of an energy efficient protected LR-PON architecture. *Proceedings of IEEE Optical Network Design and Modelling, University of Essex, UK, 2012.*