

Gecombineerde elektrische toepassingen in transport

Combined electric applications in transport

Alex Van den Bossche

Laboratory of Electrical Energy EELAB, EESA, Ghent University,

Sint-Pietersnieuwstraat 41, B-9000 Gent, Belgium

Tel. 0032 9 264 34 19 Fax 0032 9 264 35 82

e-mail: Alex Van den Bossche@ugent.be

ABSTRACT

Maximizing the efficiency in transport vehicles will be a necessity. This may be realized by introducing a power electronic conversion between the Internal Combustion Engine (ICE) and the wheels. Hence the ICE may be used at its maximal efficiency point. One still can choose the kind of fuel: liquid or gas hydrocarbons, hydrogen, alcohol.

The ICE delivers electrical power by means of a high efficiency generator and rectifier. Further on one can recover electrical energy from the exhaust thermal power by means of a bottom cycle. A solution is to use an organic rankine cycle for this. The motion itself is done by high efficiency converters and permanent magnet motors. One can reduce gear losses while using direct drive wheel motors. In ships one can also optimise the propeller and the number of propellers.

1. INTRODUCTION

In the today situation of reduction of oil availability (peak oil) and global warming (Kyoto), it is not acceptable to spoil large energy flows.

So we will try to use each Joule or kWh several times before leaving it to the environment.

On one side the technique of ICE engines are optimized close to their maximum power point.

Their efficiency is good, as the combustion temperature is much higher than the wall temperature and the heat exchange to the wall is minimal.

In large diesel engines, one gets a specific fuel consumption in large engines above megawatt of about 0.2 kg/kWh mechanical, corresponding with an efficiency of about 50% at the diesel level. However practical vehicles use the engine in various conditions as idling and negative torques, reducing dramatically the observed average efficiency.

In vehicles, potential energy (height) can be converted in kinetic energy or into chemical energy like batteries. The real lost energy is the friction energy: the friction of tires and to the air. In ships, the main energy loss is in friction to the water.

During years, the friction energy loss has been optimized. This means a low drag coefficient C_d . Also and over-inflated tires can help in cars.

However less has been done in the remaining energy conversion.

2. VEHICLE MECHANICAL NEEDS

2.1 General equations

Efficiency tests of motors are often done in one specific point close to the maximal power and in a single torque direction. However, for mobility we could better define 'total energy efficiency' as:

$$\eta_{tot} = \frac{\text{total friction loss}}{\text{fuel energy}}$$

The fuel energy may be oil, gas, alcohol, zinc or electrical, depending on the vehicle type. Kinetic energy or potential energy are in principle not lost and could be converted into each other or into some energy storage like batteries, super-capacitor or inertia storage. The total friction force contains tire friction and aerodynamic friction.

$$Ff(s) = C_r M g + \frac{1}{2} C_d \rho v^2 S$$

M : total mass (driver and luggage included)

C_r : rolling coefficient

C_d : drag coefficient

g : 9.81m/s² gravitation

ρ : 1.226 kg/m² air density at 15°C

S : cross section

v : speed [m/s]

For the resulting energy W in kWh and the speed c in km/h is:

$$Wc(c) := \frac{Fc \left(\frac{c}{3.6} \right) \cdot 10^5}{3600 \cdot 1000} + \frac{P_{aux}}{3600 \cdot 1000} \cdot \frac{10^5}{\frac{c}{3.6}}$$

P_{aux} = auxiliary equipment power consumption at mechanical level

c = speed in km/h

Table I: approximate parameters for a few vehicles

Quantity	C_r	M [kg]	C_d	S [m ²]	P_{aux}
Car	0.008	1300	0.3	2	300
Bike	0.005	20+90	0.8	0.5	0
Quest (velomobiel)	0.005	34+90	0.22	0.45	0
Energy 5	0.002	60+55	0.136	0.353	0

The resulting mechanical energy needs for the three vehicles are given in fig. 1:

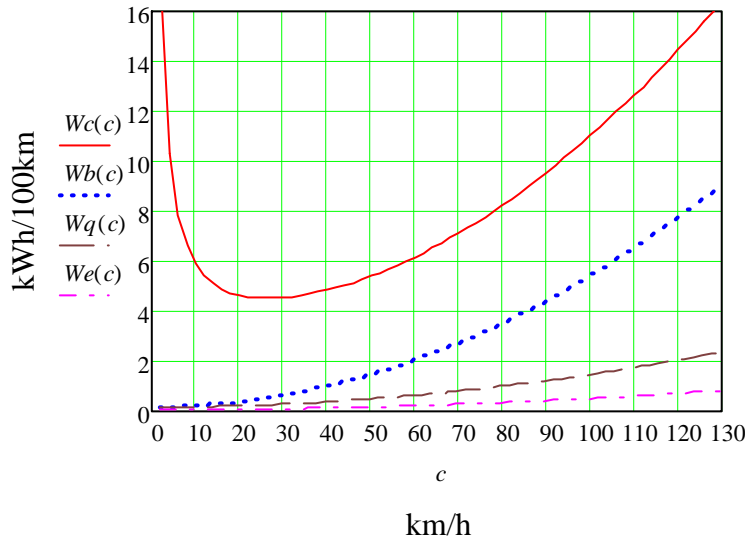

Fig. 1: Mechanical energy needs in kWh/100km for different vehicle types

W_c : car; W_b : Bike; W_q : Velomobiel quest; W_e : eco marathon type.

2.2 Typical car

The main auxiliaries in a car are electrical but are fed by actual (Lundell) alternator with a typical efficiency usually less than 60%, asking considerably more mechanical power than delivered electrical power. Also servo steering and servo brakes are a part of auxiliaries.

Driving at 20m/s (72km/h) needs about 1.8% equivalent slope to keep the speed without motor torque (own measurement on Fiat Brava at 2.6 bar tire pressure). This would correspond in a total friction power loss of 6.377kWh/100km, it is also close to the car curve in the graph Fig. 1, except for the auxiliary loss at that speed of 555Wh, which is not taken into account.



Fig 2. 'average' car approx 1300kg total, drag coefficient 0.3; 2m² cross section.

2.3 Normal Bicycle

The main advantage is its low weight (and cost). The air drag force is not especially good. If light is not considered, the auxiliary power is virtually zero.

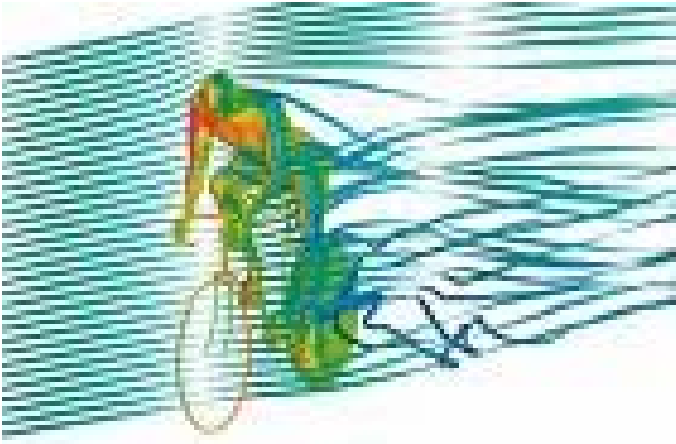

Fig 3. Normal bike approx. 110kg total.

Electric bikes can be made with 4-5kg more than a usual bike [1].

In practice, up to 50 times lower 'fuel cost' can be obtained with electrical assisted bikes (pedelec) compared to cars [1]. The reason is the total energy efficiency of electrical bike is much higher than cars and also the 'driver' helps as well.

It is a pity that the pedelec vehicle type is virtually killed by the European legislation which allows only assistance below 250W and a power gradually to zero, approaching 25km/h. So this transport type is slower than young bicycle drivers without assistance.

2.4 Aerodynamic optimized bikes

Much lower drag forces are possible, but at the expense of side wind sensibility. This asks rather for three-wheel vehicles as the 'velomobiel', which may also have auxiliary electrical drive. The forms are close to 'fish' forms.



Fig. 4: 'velomobielen', upper: mango, lower: quest [2]

2.5 Eco Marathon Vehicles

For eco marathons Michelin developed special tires with a practical friction coefficient of about 0.2% with about 5 bar on tires. However, they are frail tires not designed for normal use. They are special made for contests, but at the expense of safety and comfort: the tires are very hard, very low contact surface, have almost no profile,.

The vehicle has no mirror for looking backwards, three wheels, no front light.

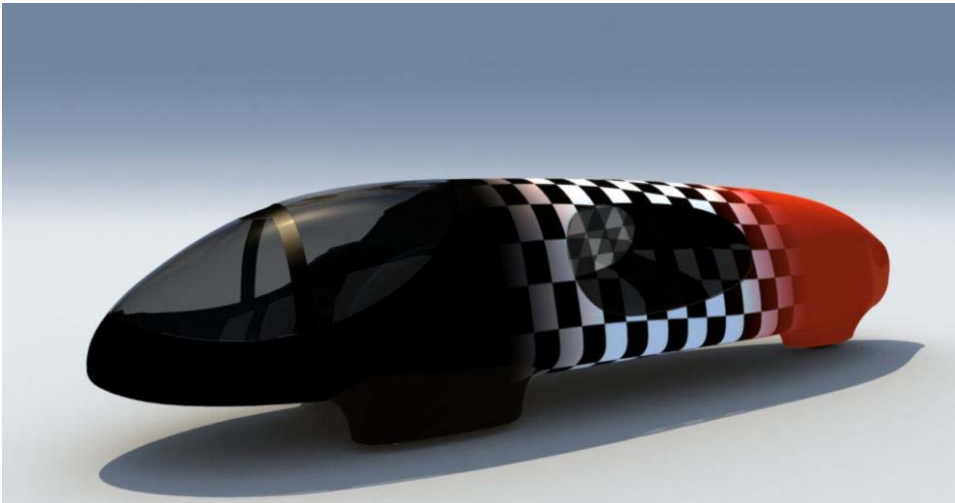

Fig 5. Energy 5, [3]

By its special form, the drag resistance is very low. The driver weight is usually 55kg. It has no suspension and the space is narrow so no much comfort is available.

It is normally not allowed as a normal vehicle on roads.

2.6 Comments

One liter of diesel is about 36MJ or 10 kWh of thermal energy.

So if a car would take 6 liter diesel/100km at 71km/h, it corresponds in 7.2kWh/100km and would result in **12% total energy efficiency** (see Fig. 1).

There are several reasons for this:

- The engine operates usually in an area of low efficiency.
- The engine still rotates at standstill and downhill.
- No fuel is flowing back into the fuel tank when braking or going downhill

These remarks seem silly for an ICE engine, but electrical drives and batteries perform easily those tasks.

Pure electric vehicles can get closer to the mechanical energy needs. With a maximal efficiency of about 90% and partly energy recuperation in downhill and braking.

The practical vehicles of tomorrow will be better as the actual today but not as good as the shell eco marathon types. A big issue is that most vehicles have a very high weight and large cross section for the average number of persons or payload they transport. This is true for cars, but also a big part of public transport and trucks.

In this point of view, single person vehicles can be very efficient in home-work distances: It is always filled at 100%, as it will not move without a driver.

Two single person vehicles could drive side by side in one lane, making traffic jams shorter. However, a perfect unique mobility solution does not exist

2 DIESEL-ELECTRIC (HYBRID SERIES) DRIVE

The fact that the diesel engine is not always at its best efficiency allows improving a drive while using a variable speed electric drive at the wheels. This was already done for half a century in railway. Energy was one reason, and traction control the other reason. It permits using the diesel engine at the optimal working condition and to vary the speed and torque electrically depending on the needs for motion.

In previous times excited alternators and diode rectifiers were used for the generator and choppers and excited DC machines for the wheel traction.

The excited DC machines contain a commutator and are not low maintenance objects. The excited alternators and DC machines have a quite low efficiency and torque density at lower power, when applied in cars or trucks.

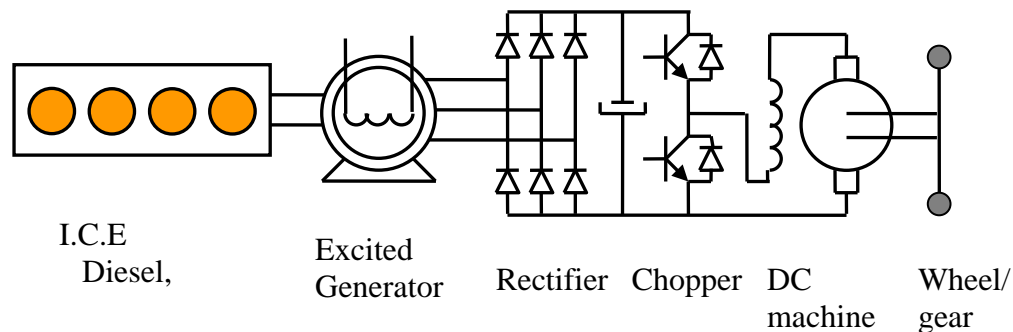

Fig. 6 Simplified Classical series hybrid Diesel-electric drive, also like in locomotives.



Fig 7 Diesel-electric locomotive 1961, using DC machines (La Brugeoise & Nivelles) [4]



Fig 8. Diesel-electric ship (four synchronous generators, induction motor drive to propeller by reduction gear) [5]

In practice, the linear speed in the air gap determines the attainable efficiency at a given copper loss density in electrical machines.

The development of those electrical motors allowed getting losses down. It also allowed considering 'direct wheel drives' or 'direct propeller drives'. So a motor runs at the same speed (rpm) as the wheel or propeller.

However, it is a good solution for not too low speed vehicles, the average vehicle speed should be rather $> 10\text{m/s}$ to obtain 5m/s in the air gap, getting about 90% nominal efficiency.

In the past years, converters became more compact and more efficient and permanent magnet AC or permanent magnet brushless DC motors are getting more common.

An approximate overview of the maximal force density in the air gap at given copper losses of 10kW/m^2 air gap and quite normal construction given in table 2.

	K [kN/m ² air gap]
Induction machine	12
DC machine	12
Synchronous machine	13
PM DC machine PM	16
BLDC Permanent magnet electronically commutated without brushes	18
PMAC Permanent magnet AC	18
Switched reluctance motor	14

So, for similar losses, the force density of permanent magnet motors is much higher. Nowadays, for direct wheel drives without gear, almost only permanent magnet drives are taken into consideration.

3 PARALLEL-SERIES DRIVES

To avoid losses in power electronic drives at high speed, drives have been developed which permit a variety of combinations like the Toyota Prius. The complexity of those systems is very high, they are expensive and need a lot of energy to in production.

In vehicles additional weight tends to decrease performance and increase consumption.

In this way the parallel-series combinations are not obvious.

Examples like the Toyota Prius are trendsetting but their performance in other emissions is better than the CO₂. Fig. 9 shows the mechanical complexity of the electromechanical part of such a drive.

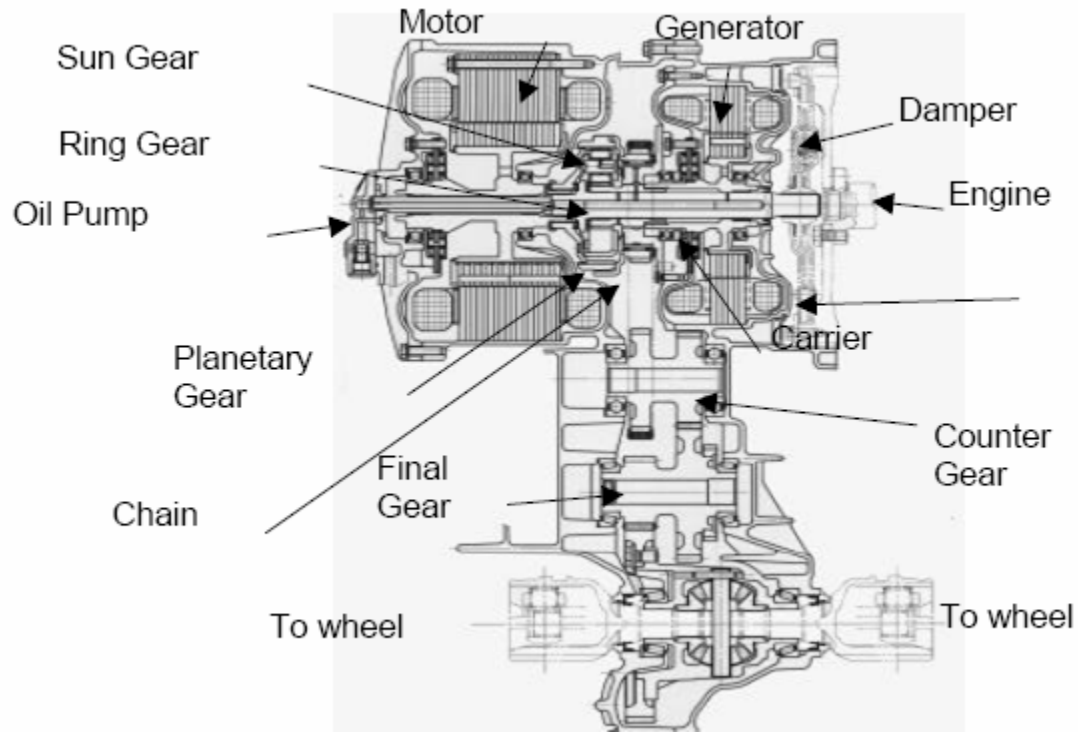

Fig 9. Motor, generator, and engine of Toyota/Prius hybrid THS II System. [6]

4 ICE-PERMANENT MAGNET (HYBRID SERIES) DRIVE

As power electronics is getting more efficient, there is a tendency to series hybrid types (fig. 10).

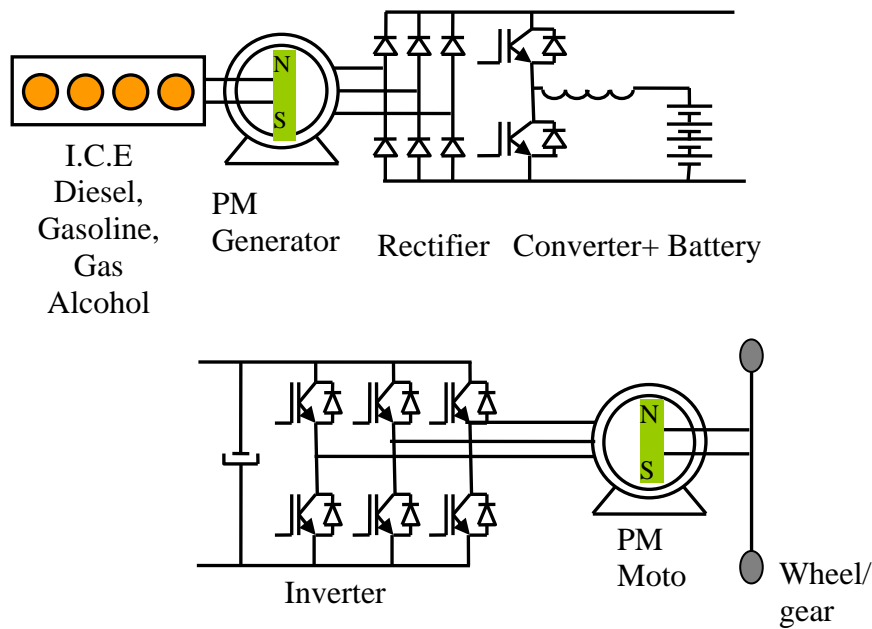

Fig. 10. High efficiency series hybrid drive, new tendency.

The ICE may be **downsized** in order to cover only the average needs of the car or even less. In that case one calls it a electric car with **range extender**. About 5-10kW range extenders could be enough to power the car. They could be made very light and use a renewable fuel like ethanol.

5 FUEL-CELL/ELECTRIC DRIVE.

4.1 Hydrogen

We know that fuel cells on hydrogen can achieve high efficiencies in the order of 50-60%. However the hydrogen is not a primary energy and for using it in fuel cells it needs to be 'pure', not be polluted by CO. So hydrogen from biomass is not so suited for fuel cells or it needs expensive treatment. The hydrogen storage needs about the weight of a Li-Fe-PO₃ battery. So the action range is not much wider than electrical cars.

4.2 Alcohol.

There are upcoming solutions with methanol (CH₃OH) but with efficiencies of about 20%. The solutions using direct ethanol (CH₃CH₂OH) fuel cells are even less common and still lower efficiencies.

I see a future in battery cars using batteries and with range extenders, based on alcohol. The advantage is compactness and low weight. As the fuel is only used occasionally the lower efficiency is less a concern. One should also consider the total efficiency starting from coal or energy crops.

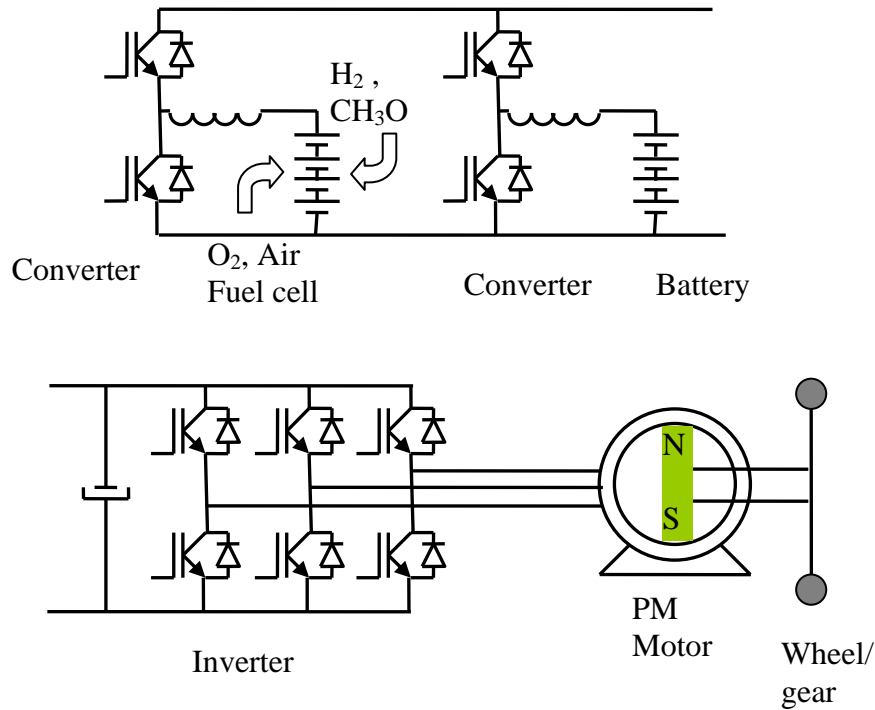

Fig. 11. Electric vehicle powered by fuel cell and battery

6 ICE-ELECTRIC DRIVE WITH BOTTOM CYCLE

The idea is to enhance the efficiency of ICE engines. A big amount of energy is still lost in cooling of the engine and the exhaust. A solution is to try to recover the useful fraction in this energy. Once the DC link is used, it could also be used to do some energy harvesting. A lot of energy is going out of the exhaust; even the cooling power could be used. This is called a “bottom cycle”. The available energy is at lower temperature, but an improved steam cycle like Organic Rankine Cycle (ORC) may be used to harvest a fraction of the lost energy. The ORC is more compact than the traditional steam cycle (Rankine cycle). We will not go into detail of those cycles and improvements [7].

The ICE engine in this case may be downsized for two reasons:

- There is a battery for delivering the necessary power for acceleration and hill climbing.
- There is additional power coming from the bottom cycle.

A well designed car could be even powered by a motor close to a lawn mower engine...

The cooling of the engine is rather a constant temperature input.

It could be kept at 150°C without too much problems for the mechanics.

It could give its heat to the environment at 50°C. The corresponding ORC efficiency would be about 10%. In the exhaust, the temperature is much higher and some 20% ORC efficiency could be achieved if done well.

Large diesels could perform better but if we start from a typical diesel with 40% efficiency at high load:

5% direct loss to ambient.

10% in cooling of the cylinders, 10% of it = 1% could be recovered by ORC

45% in exhaust, 20% of it = 9% could be recovered by ORC

Electrical generator can have 94% efficiency, and 98% efficiency for converters

The energy flow diagram of Fig. 12 shows that one can get more electrical power than the mechanical power of the shaft by using the bottom cycle using the heat loss. So the bottom cycling based on ORC has a potential to increase the total efficiency of an engine from 40% to 45% already in electrical power. The real gain is bigger as the ICE motor can be downsized and operates in a high efficient working point. Also that hill and braking energy can be partly recovered. The auxiliary equipment is supplied by a less lossy generator.

The pump and expander are much less complex and much smaller than ICE engine components.

Variants on this topology may be very useful in truck drives and ship propulsion where battery solutions are not realistic.

In ships, the electric DC link and electrical propulsion permits also the use of more than one and better matched propellers which could increase the global hydraulic efficiency of about 20%.

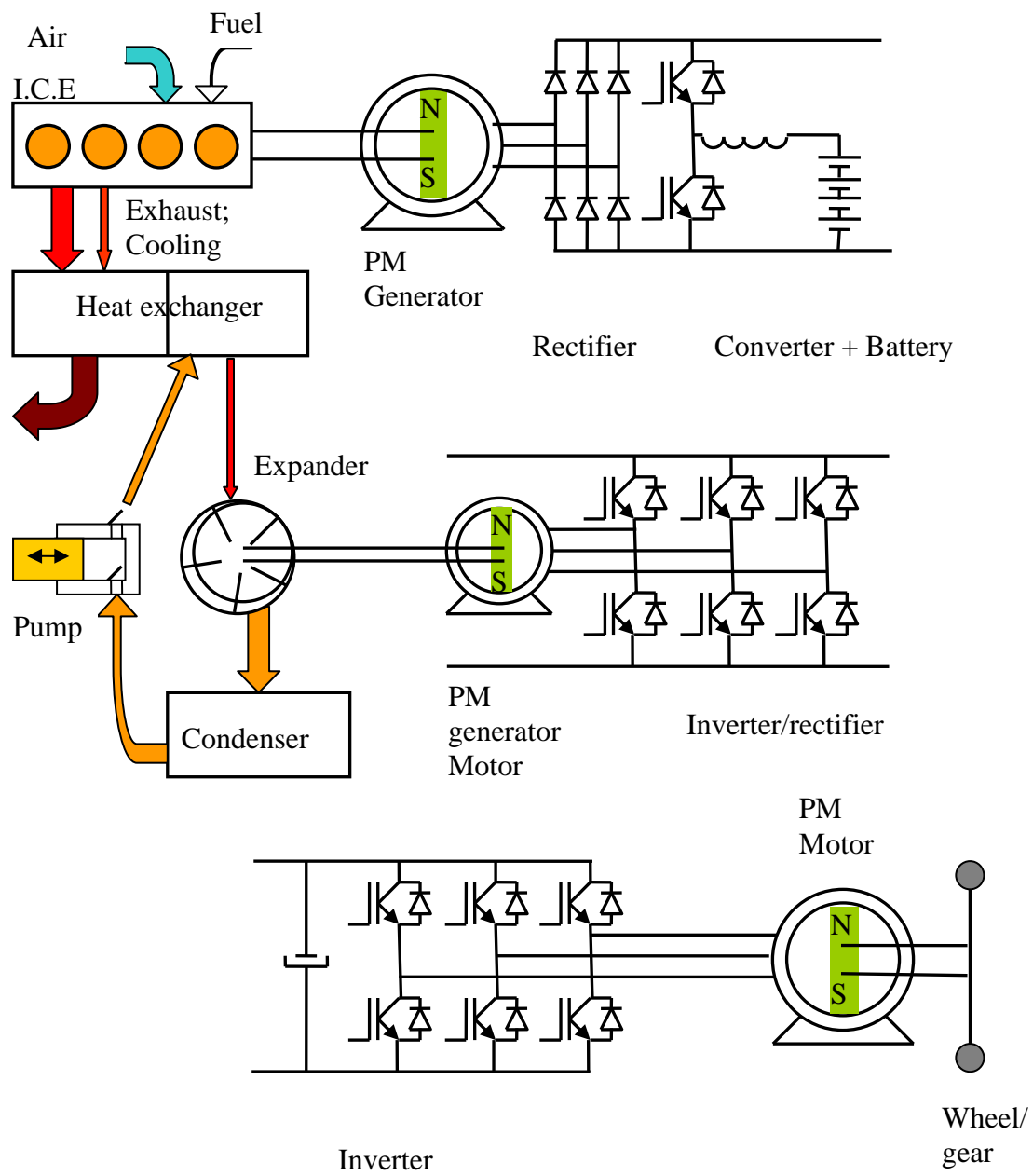

Fig 12. Combined ICE –electric with ORC bottom cycle energy recovery

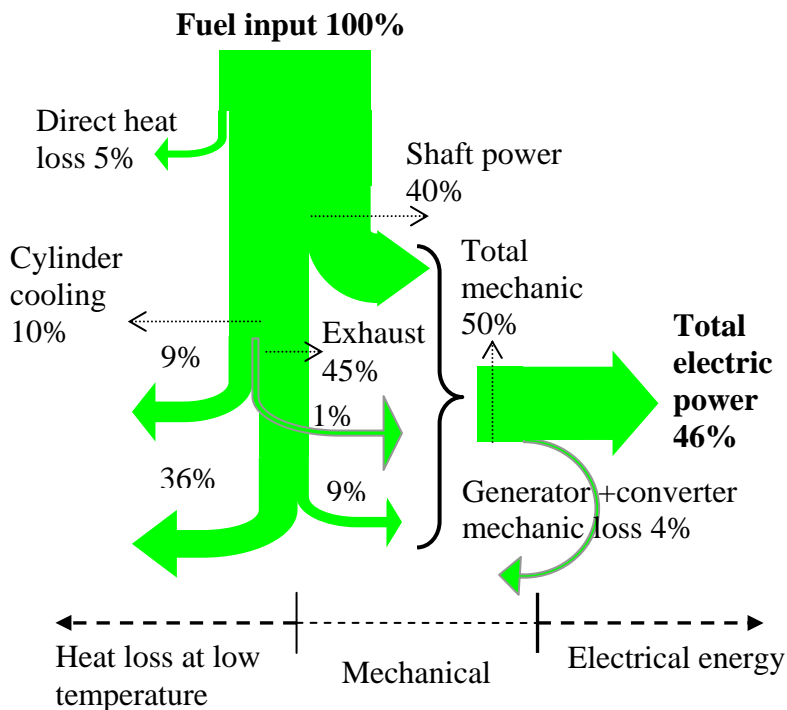

Fig 13. Energy flow diagram for combined electric motor with bottom cycle, starting from a diesel engine of 40% efficiency. but increased output by energy harvesting.

7 CONCLUSIONS

Our actual engines and vehicles can still be optimized. A lot of work has to be done in increasing efficiencies at diverse levels. A part can be improved by means of power electronic conversions. The comfort, lack of efficiency weight and volume of our today cars costs a lot in energy. One of the reasons are fractionally filled vehicles. There is a future for direct electric vehicles but also for combined electric drives. Electric drives can get close to the real energy needs of a vehicle.

8 REFERENCES

- [1]: "Sensorless BLDC control of permanent magnet axial flux motor", Emre Özkop Socrates student thesis Ugent 2005-2006
- [2]: <http://www.velofilie.nl/english/trikes.htm>
<http://www.velofilie.nl/vermogen.htm>
- [3]: Energy team Hogent, Ghent Belgium, <http://www.energyteam.be>
- [4]: http://nl.wikipedia.org/wiki/HLD_62
- [5]: April 2007,
http://www.industry.siemens.com/Marine/en/news/Spotlight/AIDADiva_070507.htm
- [6]: "Report on Toyota/Prius motor desin and manufacturing assessment", J. S. Hsu, Ph.D. C. W. Ayers C. L. Coomer, July 2004.
- [7]: Alex Van den Bossche , Bart Meerrman, "An improved combined heat power system" European patent Organisation EPO op 9 july 2007, now in PCT, 16pages+6 pages drawings.