

## A conformable Active Matrix LED Display

Ashutosh K. Tripathi<sup>1</sup>, Edsger C. P. Smits<sup>1</sup>, Jan-Laurens van der Steen<sup>1</sup>, Maarten Cauwe<sup>2</sup>, Rik Verplancke<sup>2</sup>, Kris Myny<sup>3</sup>, Joris Maas<sup>1</sup>, Roel Kuster<sup>1</sup>, Sami Sabik<sup>1</sup>, Mitsuhiro Murata<sup>5</sup>, Yoshihiro Tomita<sup>5</sup>, Hideki Ohmae<sup>5</sup>, Jeroen van den Brand<sup>1</sup> and Gerwin Gelinck<sup>1,4</sup>

<sup>1</sup> Holst Centre / TNO, High Tech Campus 31, 5656 AE Eindhoven, The Netherlands

Tel.: +31-404020571, E-mail: [ashutosh.tripathi@tno.nl](mailto:ashutosh.tripathi@tno.nl)

<sup>2</sup> imec- Ghent University Technologiepark 914A, B-9052 Gent, Belgium

<sup>3</sup> Imec Kapeldreef 75, B-3001 Leuven, Belgium

<sup>4</sup> Eindhoven University of Technology, P.O. Box 513, 5600 MB Eindhoven, The Netherlands

<sup>5</sup> Advanced Research Division, Panasonic Corporation, 3-1-1, Yagumo-naka-machi, Moriguchi, Osaka 570-8501, Japan

### Abstract

In this work we present a conformable 32x32 active matrix display using LEDs mounted on an amorphous Indium-Gallium-Zinc Oxide (a-IGZO) TFT backplane. A two-transistor and one capacitor (2T-1C) pixel engine based backplane, fabricated on polyimide substrate, is used to drive LEDs. Rigid LED pixels are connected via meandered copper film. The meander interconnections have been optimized with respect to their electrical and mechanical properties to provide a display with a 2 mm pitch between the pixels and good conformability. At an operating supply voltage of 7 V, the average brightness of the display exceeds 170 cd/m<sup>2</sup>.

### Introduction

Conformable and stretchable displays can be integrated on complex surfaces. Such a display can assume the shape of a conformed surface by simultaneous multi-dimensional stretching and bending. Such technology provides new opportunities in the field of display applications, for example wearable displays integrated or embedded in a textile or onto complex surfaces in automotive interiors. For an AMOLED display, the main challenge in implementation of such a concept is imposed by patterning of pixelated multi-layer humidity barrier. The possibility to replace OLED with inorganic LEDs, less sensitive to humidity and oxygen, provides an attractive proposition. Stretchable and deformable LED arrays integrated on flexible substrates have been demonstrated [1,2]. As a next step, an active-matrix driving scheme would enable larger displays driven at relatively lower voltages, higher refresh rates, higher brightness, and better uniformity compared to passive-matrix driving due to the less stringent conditions on voltage drop across the interconnect metal lines. Active matrix driving has been demonstrated on displays with LED frontplane on glass [3] and. In this work we successfully realized a conformable 32 x 32 AM-LED display on foil combining a IGZO TFT backplane with stretchable meander wire technology. Displays had a pixel pitch of 2 mm and exhibited a good conformability with average brightness exceeding 170 cd/m<sup>2</sup> at a supply voltage of 7V.

### Display Fabrication

The AM-LED display backplane consists of a pixelated a-IGZO TFT backplane fabricated on polyimide. **Figure 1(a)** shows the cross section of AM-LED pixel. A micrograph of fabricated AM-LED pixel is shown in **figure 1(b)**. The backplane technology is based on an etch-stop layer (ESL) TFT lay-out. First, a 38  $\mu\text{m}$  thick polyimide with smooth surface was laminated on a glass carrier plate. Subsequently, a 30 nm Al<sub>2</sub>O<sub>3</sub> layer was deposited using atomic layer deposition acting as a buffer layer to protect the polyimide film during subsequent process steps. A 100 nm thick Mo-Cr layer was used as gate and source-drain electrode metals. For gate insulator 200 nm PECVD SiOx was applied. IGZO was deposited via DC-sputtering and PECVD SiOx ESL layer was deposited in order to protect the TFT channel. All PECVD dielectric layers were etched outside the rigid pixel area in order to avoid strain induced cracking and crack propagation during the stretching/bending operations [4]. After the fabrication of TFT pixel islands, a photo-patternable polymer layer was deposited as an interlayer dielectric.

Anode and cathode for the LEDs were made by patterning of a 400nm sputtered Cu film. Meander shaped connecting lines were defined in the same photolithography step. IGZO TFTs exhibit an electron mobility  $\sim 10 \text{ cm}^2/\text{Vs}$ , threshold voltage  $\sim 0\text{V}$  and very good uniformity across the whole display area. TFTs were further tested for mechanical and thermal reliability in order to ensure no degradation in TFT backplane during subsequent process steps. Electrical and mechanical properties of IGZO TFTs on polyimide are reported elsewhere [5].

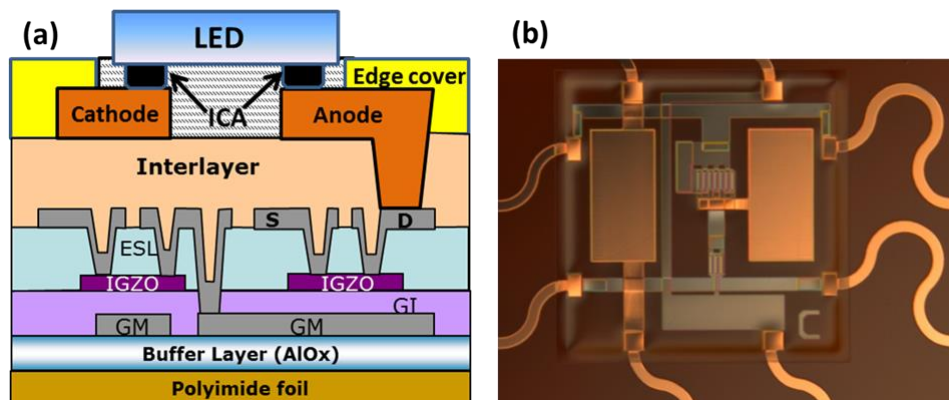

**Figure 1. (a) Schematic representation of AM-LED pixel. (b) Micrograph of an AMLED 2T-1C pixel.**

**Figure 2** shows the design of AM-LED display. A pixel pitch of 2 mm employed with horseshoe shaped interconnect lines enabling high level of mechanical robustness during the conforming or stretching operations. Subsequently an isotropic conductive adhesive (Ablestik CE3104WXL) was deposited via stencil printing on the anode and cathode pads of the display and the LED's were placed onto the circuitry using pick and place technology and cured at  $120^\circ\text{C}$  for 15 mins. Based on known LED and TFT characteristics, the geometry of the drive TFT set to  $W/L = 450/15 \text{ } (\mu\text{m}/\mu\text{m})$  to allow for sufficient current drive ( $\sim 135 \text{ } \mu\text{A}$ ) under normal operating conditions, i.e. supply voltage  $V_{\text{DD}} = 7\text{V}$  and data voltage  $V_{\text{DATA}} = 12\text{V}$ .

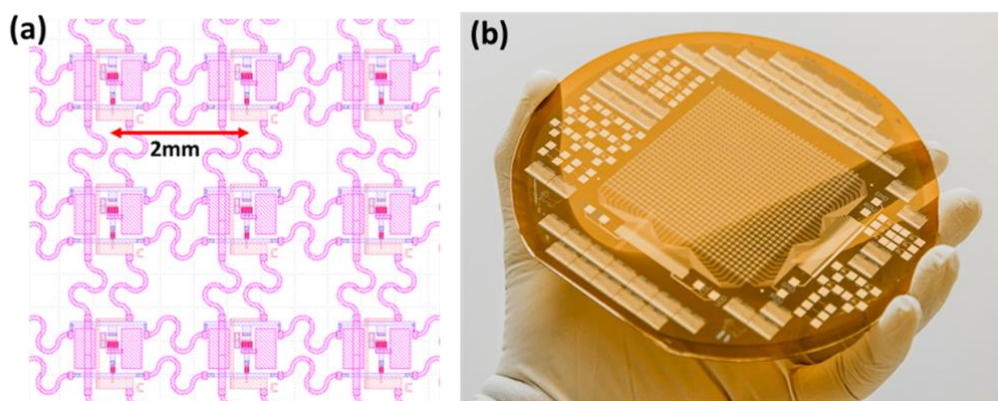
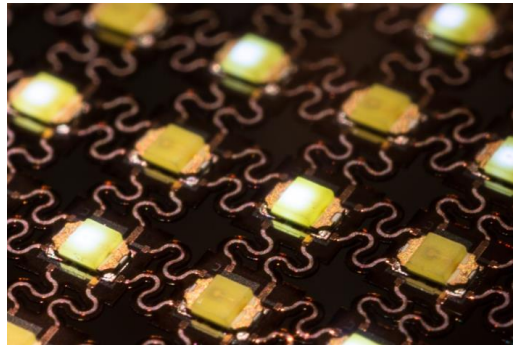

**Figure 2. (a) Design of AM-LED display array. (b) Photograph of IGZO TFT backplane on polyimide on 150-mm glass carrier.**

### Laser machining and debonding and display characterization

After LED bonding, a flex-bonding process was used to attach flex-cables to the display providing a connection to external display driving electronics. After the flexbonding procedure, the polyimide foil was patterned to yield isolated LED pixel area connected by meander lines. The patterning was realized using a frequency tripled Nd:YAG laser in combination with a galvano scanning system. The laser parameters were optimized to minimize the heat affected zone and thereby reducing possible stress induced crack during the ablation process. After laser patterning, the display was released from its glass carrier using an optimized laser release process.

Mechanical stability and protection from the environment while not hindering the conformability of the display was enhanced by encapsulating the display in a thin thermoplastic polyurethane film (TPU). **Figure 3** shows a detail of the AM-LED display. Here, the pixels are driven alternatively in the ON and OFF state (a checkerboard pattern). The image clearly shows the laser machined meanders connecting the pixels.



**Figure 3. Photograph of the pixels in array. A checkerboard pattern of ON and OFF pixels is shown**

**Figure 4(a)** shows the luminance measured over an area of 4x4 pixels. The average luminance, measured over an area of  $\sim 4\text{cm}^2$  is found to be  $170\text{ Cd/m}^2$  with peak luminance in the pixel around  $3700\text{ cd/m}^2$ . Since LEDs are point source of light emission and pixel pitch of the display is large, the average brightness of the display is lower than the peak brightness of discrete LEDs. Symbols in **Figure 4(b)** represent average luminance versus the supply voltage. The measured values are in excellent agreement with individual TFT driven LED luminance normalized with respect to the measured average display luminance at a supply voltage of 9 V. This shows that the average luminance of the AM-LED display follows the same behavior as that of discrete LEDs, indicating good uniformity of the display. **Figure 4(c)** shows the luminance versus data voltage, with  $V_{DD}$  set to 5V and 7V. The predominantly linear behavior in the  $V_{DATA}$  range of 9V-13V allows for accurate gray scale representation.

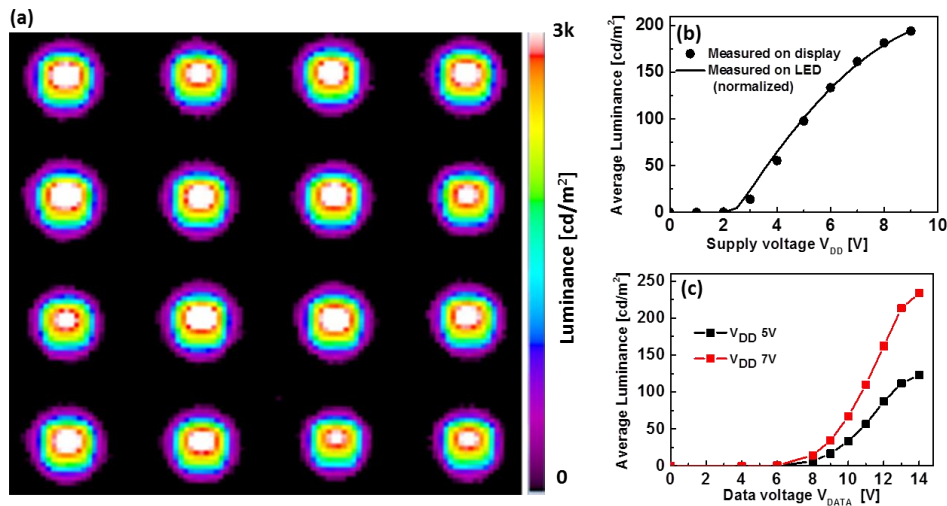

**Figure 4. (a) Homogeneity image of AM-LED array measured at  $V_{DD}$  of 7V and  $V_{DATA}$  of 12 V. The colors represent the luminance on a linear scale from 0-3000  $\text{Cd/m}^2$ . (b) Measured average luminance of the display (symbols) and normalized LED luminance (line) at different supply voltages. (c) Average display luminance versus data voltage, for different supply voltages.**

**Figure 5** shows the AM-LED display driving demonstrated in flat as well as conformed conditions. In addition to conformability, laser machining also enables semi-transparency in such display as depicted in **figure 5(c)**.

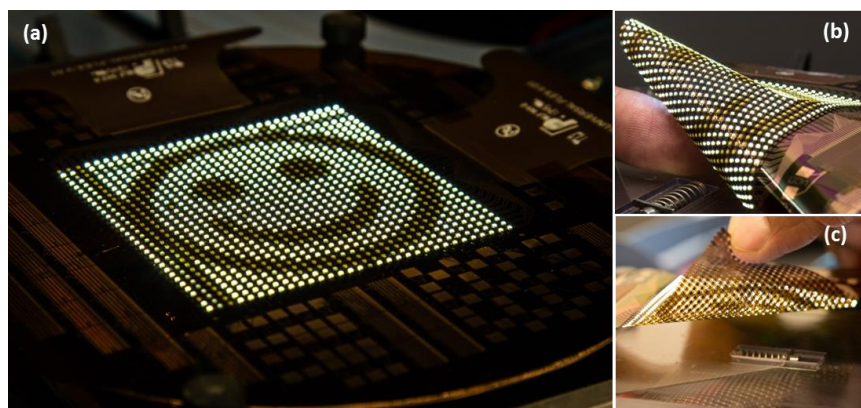

**Figure 5.** A 32x32 AM-LED display driving while still bonded to the glass carrier (a) and after debonding (b, c).

Characterization parameters are summarized in Table 1.

**Table 1.** Specifications of the developed stretchable display

Item	value
Pixel Number	32 x 32
Resolution	2 mm pitch (13 ppi)
Brightness	170 cd/m <sup>2</sup> (V <sub>dd</sub> = 7V)
LED chips	SMLP12WBC7W
Driving scheme	Active (2T-1C)

The excellent conformability enables us to mount such a display on a complex shaped surface. Furthermore, relying on an active matrix driving enable a scalable technology for large array of flexible and conformable LED displays without any significant loss in the uniformity where standard AMOLED display driver ICs can be used for driving.

## Conclusion

A conformable and stretchable 32X32 AM-LED display with a-IGZO TFT backplane is presented for the first time. Display has a pixel pitch of 2mm and shows a brightness of 170 Cd/m<sup>2</sup>. The display shows high level of flexibility and can be conformed on complex surfaces. Demonstrated conformability can enable various new applications; for example, in the field of wearable displays and automotive. Further miniaturization and smaller LED integration will result in higher-resolution and higher-brightness conformable displays in the future.

## Acknowledgement

We thank Marc Koetse for the photographs of displays. We acknowledge the support provided by Gert van Heck in display driving.

## References

- [1] H. Ohmae et al., SID 2015
- [2] S.-I. Park et al., SCIENCE VOL 325, 977 (2009)
- [3] 55" Crystal-LED TV by Sony, at 2012 International CES, Jan. 9 -12, Las Vegas (2012)
- [4] Wagner et al., in Flexible Electronics – Materials and Applications, ISBN 978-0-387-74362-2, 2009
- [5] F. Li at al., SID 2014