

USING A NEW DEVELOPED DIE AND DIFFERENT TYPES OF THERMOSETTING RESINS TO PRODUCE U200 PROFILES BY PULTRUSION

J.P. Nunes¹, D. Melo² and M. Vasconcelos³

¹Institute of Polymers & Composites/I3N, Minho University
Campus de Azurem, 4800-058 Guimaraes, Portugal
Email: jpn@dep.uminho.pt, web page: <http://www.ipc.uminho.pt>

²Department of Polymer Engineering, Minho University
Campus de Azurem, 4800-058 Guimaraes, Portugal
Email: davidmelo@outlook.pt, web page: <http://www.dep.uminho.pt/dep/en/>

³Department of Engineering, Vidropol SA
R. Augusto Nogueira da Silva, 1970, Apt 2001, Castelo da Maia, 4476-909 Maia, Portugal
Email: Miguel.vasconcelos@vidropol.pt, web page: <http://www.vidropol.pt>

Keywords: Pultrusion, Polyester and vinylester thermoset matrices, Heated die, Mechanical properties

ABSTRACT

In this work, a new steel heated pultrusion die was designed, developed and manufactured to produce U200 glass fibre reinforced thermosetting matrix (GRP) profiles [1]. The finite element analysis (FEA) was used to predict and optimise the developed die heating by using cylindrical electrical powered cartridges. To assess the new die performance it was mounted in the 120 kN pultrusion line of the Portuguese company Vidropol SA and used to produce continuously U200 profiles able to meet all requirements specified for the E23 grade accordingly to the European Standard EN 13706: 2002 [2].

After setting up the type, orientation and sequence of layers in the U 200 laminate, different types of thermosetting resins were used in its production. Orthophthalic, isophthalic and bisphenolic unsaturated polyester as well as vinylester resins were used to produce glass fibre reinforced U 200 composite profiles. All applied resins were submitted to SPI gel tests in order to select the more appropriated catalyst system and optimise the processing variables to be used in each case, namely, pultrusion pull-speed and die temperature. The best pultrusion operational conditions were selected by varying and monitoring the pull-speed and die temperature and, at the same time, measuring the temperature on the manufactured U 200 profile during processing.

Finally, the produced U200 profiles were submitted to visual inspection, calcination and mechanical tests, namely, flexural, tensional and interlaminar shear strength (ILSS) tests, to assess their accomplishment with the EN 13706 requirements.

1 INTRODUCTION

Pultrusion has been and, on all the available evidence, is likely to remain as one of most attractive sector and presenting major growth of the whole composites industry. Currently, non-structural and structural composite pultruded profiles are being increasingly more applied in the following markets: construction, particularly in environments presenting corrosive conditions, electric, marine and transportation markets [3]. The excellent mechanical properties, electrical, acoustic and thermal insulating characteristics, high corrosion resistance and integrity and low weight are some of the main reasons for the success of pultrusion profiles in the market.

In this work a new heated die was developed and constructed to allow the Portuguese manufacturer Vidropol SA producing by pultrusion U 200 glass reinforced composite profiles for being employed in structural applications. After optimising the glass fibres impregnation/guiding and feeding system in

the equipment and defining the profile laminate stacking that allow achieving the desired mechanical properties, the new die was mounted in the 120 kN pultrusion equipment from Vidropol SA for testing. Different thermosetting matrices were used to manufacture the U shaped 200 glass reinforced profiles and processing window conditions defined. Finally, the U 200 produced profiles were tested to assess their accordance with the requirements of the E23 grade defined in the European Standard EN 13706: 2002 in order ensure their successfully launch in the commercial market.

2 DEFINING THE PULTRUSION PROCESSING CONDITIONS

2.1 Pultrusion equipment used

The 120 kN pultrusion equipment from Vidropol SA that have been used in this work is schematically shown in Fig.1.

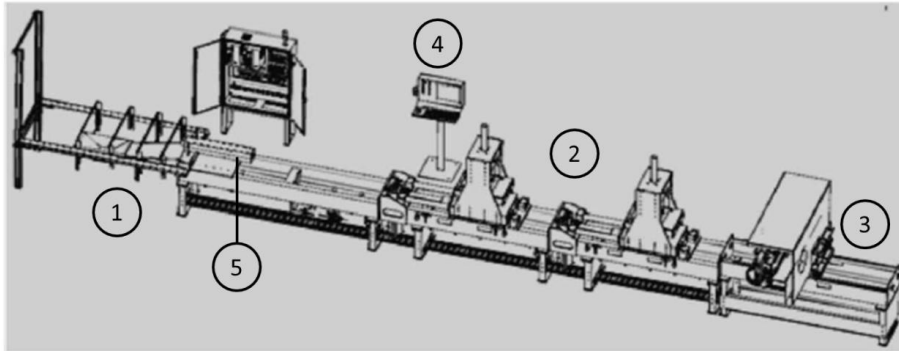

Figure 1: Schematic drawing of the 120 kN pultrusion machine from Vidropol SA.

As may be seen in the figure the equipment is composed by five main systems: 1) fibres impregnating, guiding and feeding one; 2) pulling; 3) final cutting; 4) main command panel and, finally, 5) the profile die.

2.2 Adapting the fibres impregnating/guiding/feeding system

Before beginning the production of any new pultrusion profile is necessary to build a novel impregnating/guiding/feeding in order to ensure that the already impregnated fibres took roughly the shape of the final profile cross section nearby the entrance of the pultrusion die. In this work, such operation became more complex than the usual one due the large dimensions of the cross section of the U200 profile to be pultruded (see dimensions/drawings in Fig 4 of next paragraph 2.3). Larger profile cross sections mean using higher number of glass fibre roving strands and other fibre layers.

As may be seen in Fig. 2, a solution was achieved by placing two perforated polyamide (PA) plates before the steel die entrance to guide and shaping the different fibre strands and layers to the die geometry.

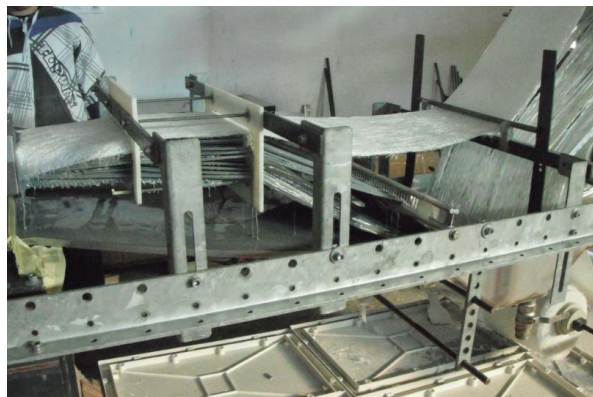
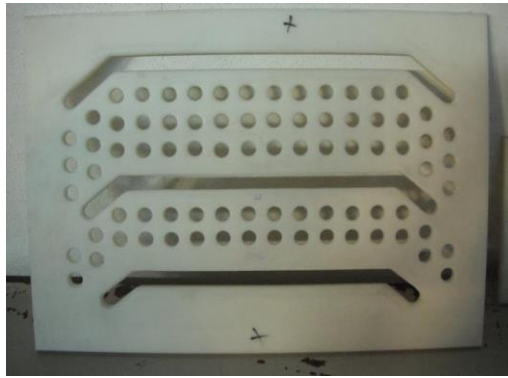

Figure 2: The two PA perforated plates used to guide glass fibres nearby the steel die entrance.

The perforated PA plates used may be seen with more detail in Fig. 3.



a) 1st guiding plate placed far from the die entrance

b) 2nd guiding plate closer from die entrance

Figure 3: More detailed images of the PA perforated plates used to guide fibres at the die entrance.

To ensure the adequate impregnation of the glass fibres it was also necessary improving and adapting the guiding system between the glass rovings storage shelves and the liquid resin impregnation basin entrance (see Fig.4).



Figure 4: Detail of guiding mechanism at the resin impregnation basin entrance

2.3 New U200 heated diedeveloped

Fig.4 presents the dimensions of the U 200 glass fibre reinforced profile to be produced.

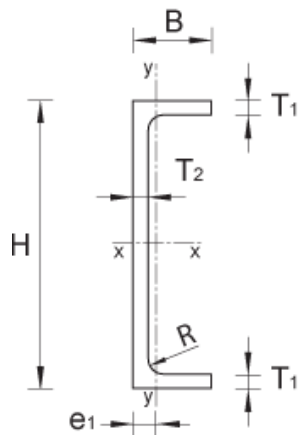

	H	B	T ₁	T ₂	e ₁	R
Dimensions (mm)	200	60	10	10	15.2	10

Figure 4: Dimensions of the U 200 glass fibre reinforced pultruded profile.

On other hand, Fig. 5a) exhibits the extremity of the $1400 \times 290 \times 137$ (mm) steel die developed to produce the above shown U 200 composite profile by pultrusion. All internal die surfaces have been hard chrome plating treated and 28 CHC M10 screws, accordingly to DIN 912, used to tightly fasten the higher to lower die part. Such screws were calculated in order to support a maximum pressure of 13.8 bar in the interior of the die [3]. It was also ensured that the die supported by its extremities was able to withstand its own weight plus the sum of the weight of all heating cartridges and composite material distributed along its entire 1400 mm length without overpassing a vertical bending displacement of 0.01 mm (see Fig. 5b)). In such case, the maximum vertical displacement, y_{max} ; was calculate as:

$$y_{max} = \frac{5 \cdot p \cdot L^4}{384 \cdot E \cdot I} \quad (1)$$

where,

p is the total weight distributed along all the die length

L is the total die length ($L=1400$ mm)

E is the Young modulus of steel ($E= 210 \times 10^3$ MPa)

I is first moment of inertia of the die cross section area (mm^4)

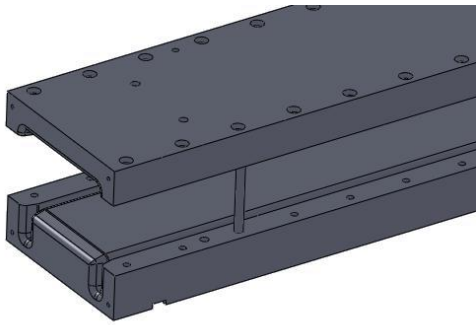

a) Extremity of the developed pultrusion die

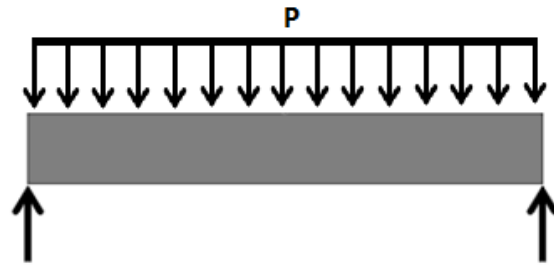

b) Bending load distributed along the die length

Figure 5: Developed die.

Finite element analysis (FEA) was used to optimise the system of cylindrical electrical cartridges that should be used for heating the die and predict its temperature evolution. The software SolidWorks® [5] was used in the simulations considering the heat transfer problem in transient regime and the other following assumptions: i) all adjacent superficies are in perfect contact, ii) the die presents a simplified geometry and, iii) a constant temperature distribution along time by considering that the one defined in the work carried out by Xiao Lin Liu, et al. [6] was adequate to the range of temperatures used during the production of the composite profile. Additionally, the die was supposed to be at the initial temperature of 125°C, the convection coefficient has been taken as $10 \text{ W}/(\text{m}^2 \cdot \text{K})$ and the external room temperature was considered 25°C.

To decrease calculation time a tetrahedral (4 nodes) mesh with 89233 elements was used in the model (see Fig. 6).

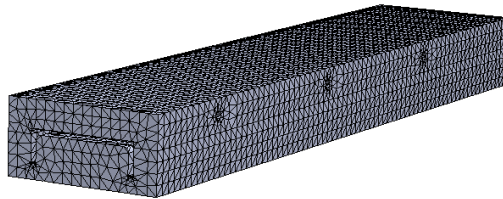

Figure 6: Tetrahedral (4 nodes) mesh used in the FEM simulations

Figures 7 shows the positions where thermocouples and the different cylindrical heating cartridges were placed. Each colour corresponds to a one different heating cartridge group having the characteristics defined in Table 8.

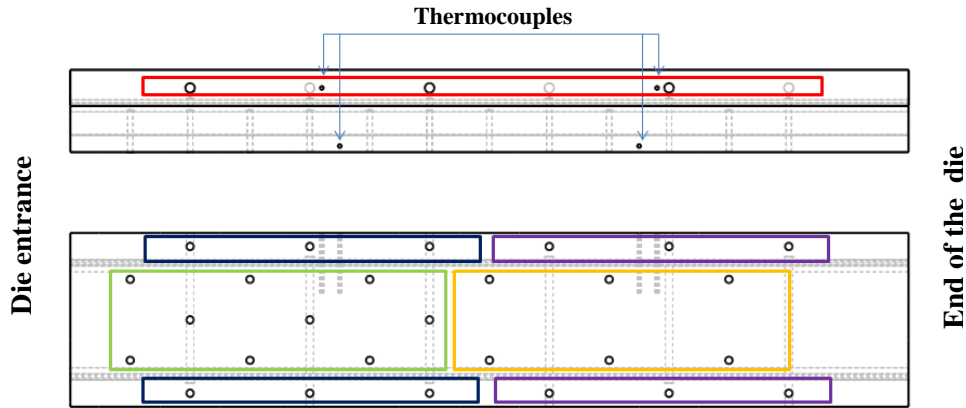
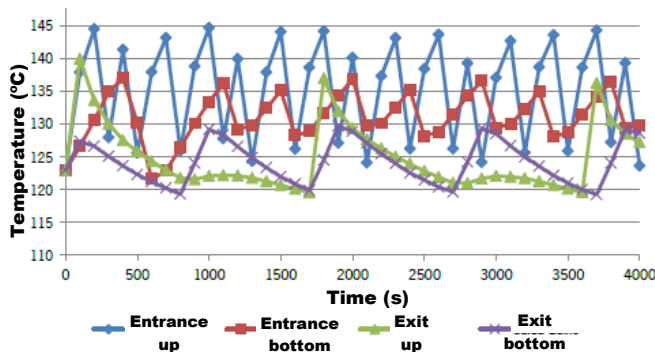

Figure 7: Positions of the heating cartridges and thermocouples

Cartridge group	Power (W)	Diameter (mm)	Length (mm)
Red	1000	16	250
Orange	400	12.5	70
Blue	500	12.5	90
Violet	400	12.5	90
Green	500	12.5	70

Table 1: Groups of the electric cartridge shown in Fig. 7

Figure 8 exemplifies two typical simulations made by using the above model. The simulation shown in Fig. 8a) presents the evolution of the die temperature near the zone where the four thermocouples were installed, two in upper part of the die and the other two in its bottom part, during a 4000 s heating and to allow maintaining temperatures in the range of 130°C - 135°C and 120°C - 125°C on the die entrance and exit, respectively. As it may be seen, the cartridges mounted nearby die entrance die switched automatically with much higher frequency “on” and “off” than those installed near the exit of the die due to the constant feed of new cold material.



a) Temperature at the die entrance and exit

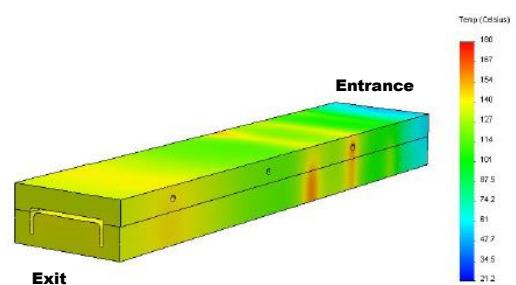

b) Die temperature after a 37.6 min of heating

Figure 8: Simulation of the evolution of the temperature on the U200 die

On other hand, Figure 8b) exhibits the temperature in the die after 2000 s (37.6 min) of heating time. The lower temperatures that may be seen in the die entrance side also reflect the continuous feeding of new cold material to the die.

2.4 Validating the heating die simulations

As soon the new developed die became available it was mounted in the pultrusion equipment for testing (see Fig. 9a)). Digital thermocouples were placed on the upper part of die to measure the temperature evolution along its length and assess the heating die FEM predictions. The tests were conducted at the pull speed of 400 mm/min using the orthophthalic polyester Resipur[®] 2208 from Resiquimica SA combined with two initiators, the Peroxan[®] PB % and Peroxan[®] BP Pulver 50w from Pergan, in mass contents of 1% and 2%, respectively. Furthermore, calcium carbonate was also added to the resin in a mass content of 5%

As Fig. 9b) shows, the evolution of temperature obtained experimentally along the die length is quite similar to the one predicted from FEM simulations. An average difference of 4% was obtained between results and, only slightly higher temperatures were predicted by FEM on the die, in the range from 0.35 m and 0.6 m, with a maximum difference of 16% nearby the 0.4 m.

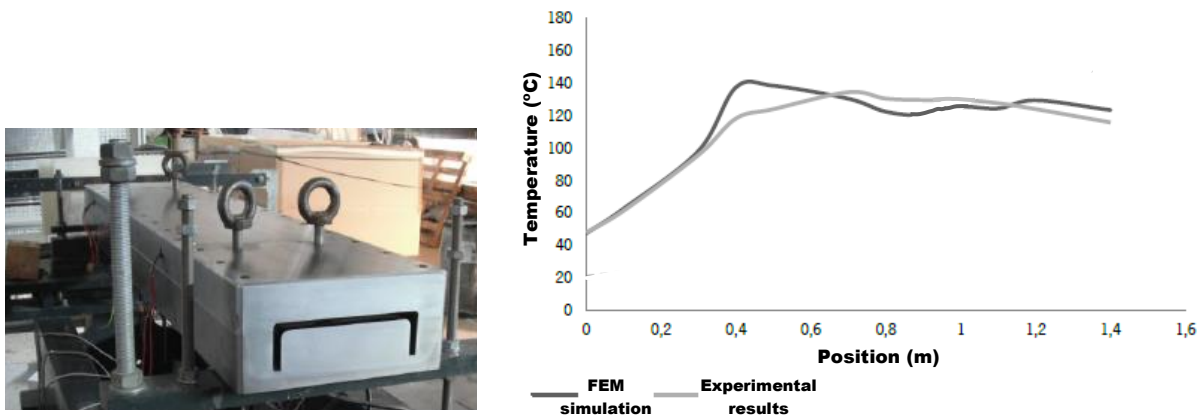

a) Die mounted on the pultrusion equipment

b) Comparison between simulations and experimental results

Figure 9: Comparison between the temperatures obtained experimentally and from FEM simulations.

Additionally, it was observed a maximum difference of about 6% between the temperature measured on the U profile manufactured (138 °C) and that one (147 °C) predicted in the simulations carried out in the work carried out by Xiao Lin Lui et al [6]. Thus, it was possible to conclude that all experimental results obtained seemed to be in good agreement with the predictions from FEM simulations.

3 LAMINATE: TYPE AND SEQUENCE OF LAYERS

Almost all final properties of the fibre reinforced profiles made by pultrusion become determined by the laminate chosen, i. e. type, sequence and fibre content and orientation in each layer. In this work, the laminate for the U 200 glass reinforced profiles was mainly selected to ensure they accomplish the requirements, namely the mechanical ones, established for the E23 grade (see Table 8 under paragraph 5) in the European Standard EN 13706: 2002 [2].

A 10 ply symmetrical laminate, using 260 glass rovings of 9600 Tex divided by two unidirectional layers, [Mat 450 / plain fabric 500 / unidirectional roving (0°) / plain fabric 500 / Mat 50]_s has been selected. By using such laminate it was possible predicting to attain, in the longitudinal direction of fibre reinforced profile to be produce, the minimum tensile modulus value of 23 GPa required for the E23 grade of the EN 13706: 2002 (see Table 8 under paragraph 5).

In fact, an Young modulus of 27,7 GPa was predicted for the longitudinal direction the full section of the GRP profile to be produced with the above laminate, by using the rule of mixtures and well-

known equations from the micromechanics/macromechanics of composite layers and assuming the properties of raw materials and layers depicted in Table 2 [3, 7-10]. Such predicted value for the longitudinal modulus assumes that the Mat, plain fabric and unidirectional roving layers will occupy, respectively, volume contents of approximately 31%, 20% and 49% in all full section of the GRP profile.

Component	Young Modulus (GPa)		Density (kg/m ³)	Fibre volume content (%)	Fibre mass content (%)
	Fibre direction	Direction transverse to fibres			
Glass fibres	70.0 ^a	-	2550 ^a	-	-
Orthophthalic polyester Resipur [®] 2208	3.0 ^a	3,0 ^a	1130 ^a	-	-
Layer of unidirectional glass fibres (0°)	43.4 ^c	5.5 ^c	2010 ^c	62 ^c	78.5 ^b
Layer of Mat 450 g/m ²	7.35 ^c	7.35 ^c	1528 ^c	28 ^c	47.0 ^b
Layer of plain fabric 500 g/m ²	20.3 ^c	20.3 ^c	1954 ^c	58 ^c	75.5 ^b

^a From manufacturer datasheets; ^b Values based in previous tests & experience; ^c Calculated values

Table 2: Raw materials and layers properties based on manufacturers datasheets and experience

Additionally, the prevision made assumes that fibre mass and volume fractions of 61.8 % and 48.5 %, respectively, will be obtained in the final GRP profile. These values were in good agreement with those ones already determined in other GRP profiles with different transversal sections produced in similar conditions using the same equipment. It must be also mentioned that for the selected laminate it was also possible to predict a Young modulus of 9.0 GPa in transversal direction of the GRP profile cross section, which is value higher than the minimum 7 GPa figure (Table 8 under paragraph 5) required by the EN 13706: 2002 standard [2].

4 NEW THERMOSETTING MATRIX SYSTEMS

In addition to the commonly used orthophthalic polyester resin, a study concern to the use of three new different resins was carried out in this work. Such resins were two unsaturated polyesters, one isophthalic (Resipur[®] 5103 from Resiquimica SA) and the other bisphenolic (Atlac[®] 382 from DSM), and a vinylester one (Atlac[®] 580 from DSM).

Such study was been done in three stages: i) the first one involved the choice of the catalyst system more appropriated for each resin, ii) the second concerned in defining the exact proportions that each catalyst component must be added the resin to achieve its full and adequate cure and, iii) the validation of the selected catalyst system was finally made in a third stage.

4.1 Selecting the catalyst systems

In the pultrusion process the cure of resins is usually based in a catalyst system that uses two different types of initiators [3]: i) one is the so-called “kicker”, which is more reactive and provides the faster beginning of the cure reaction at the lower temperatures existing on die entrance and, ii) a second one, so-called “finisher”, with lower reactivity and able to ensure a full and much smooth cure of the GRP profile inside the die at higher temperatures. In this work, two different catalyst systems based on the use of different “kickers” and “finishers” were studied for each of the new three thermosetting resins to be used.

In the case of the Resipur[®] 5103 isophthalic unsaturated polyester one of the catalyst systems was based on the Peroxan[®] BP-Pulver 50 W (Dibenzoyl peroxide), as “kicker”, and the Peroxan[®] PB (tert-butyl peroxybenzoate), as “finisher”, both initiators from the Pergan GmbH. Such catalyst system was the same that was already used with success to produce GRP profiles based in orthophthalic unsaturated polyester matrices. The other catalyst system tested with this resin the same “kicker” was selected (Peroxan[®] BP-Pulver 50 W) but the above mentioned “finisher” was replaced by the initiator Trigonox[®] C (ter-butyl peroxybenzoate) from the AkzoNobel.

Both catalyst systems studied for the Resipur[®] 5103 isophthalic polyester were also tested in the

case of the bisphenolic polyester resin Atlac[®] 382.

Finally, in the case of the vinylester resin two catalyst systems were studied: i) the first one applied with the other two resins using the Peroxan[®] BP-Pulver 50 W and Peroxan[®] PB, as “kicker” and “finisher”, respectively and, ii) a catalyst system usually considered more adequate to vinylester resins based in the following initiators: the Andonox Pulcat AW-PF (methyl isobutyl ketone) and the Norox TBPB (tertiary-Butyl Peroxybenzoate), both from the Syrgis Performance Initiators AB, as “kicker” and “finisher”, respectively.

To select the more appropriate catalyst system to be used with each resin SPI gel tests at 82°C, according to the ASTM D 7029 – 09 standard [4], were performed to determine the values of the gel and cure times and exothermal pic associated to each system. Then, such determined values were compared with those obtained for the already approved catalyst system used with success in the production of GRP profiles based on the orthophthalic polyester resin Resipur[®] 2208.

Table 3 shows the results obtained from the SPI gel tests made. By comparing the results obtained with the new resins to the already used orthophthalic polyester one, the following catalyst systems were selected to produce the U200 GRP profile because of closer results presented: i) initiators Peroxan[®] PB and the Peroxan[®] PB –Pulver 50 W for the isophthalic polyester Resipur[®] 5103; ii) initiators Trigonox C and Peroxan[®] PB –Pulver 50 W for the bisphenolic polyester Atlac[®] 382 and, iii) initiators Andonox Pulcat AW-PF and Norox TBPB for the vinylester resin Atlac[®] 580.

Additionally, it was also possible to conclude that, as expected, the catalyst system based on the Trigonox[®] C and Peroxan[®] BP Pulver 50 w doesn't work as curing system with the vinylester resin.

Resin	Catalyst system	Exothermal pic (°C)	Gel time (min)	Curing time (min)
Orthophthalic polyester Resipur [®] 2208	1% Peroxan [®] PB + 2% Peroxan [®] PB-Pulver 50 W	169.2	2.4	2.7
Isophthalic polyester Resipur [®] 5103	1,5% Trigonox C + 2% Peroxan [®] BP Pulver 50 w	173.2	3.0	4.0
	1.5% Peroxan [®] PB + 2% Peroxan [®] PB-Pulver 50 W	175.1	2.8	4.0
Bisphenolic polyester Atlac [®] 382	0.5% Trigonox C + 1% Peroxan [®] BP Pulver 50 w	181.0	6.9	8.3
	0.5% Peroxan [®] PB + 1% Peroxan [®] PB-Pulver 50 W	171.6	10.2	12.0
Vinylester Atlac [®] 580	1.5% Trigonox C + 5% Peroxan [®] BP Pulver 50 w	-	>30	-
	1.2% Andonox Pulcat AW-PF + 0.4 Norox TBPB	164,0	5.3	7.4

Table 3: Results obtained from the SPI Gel Tests at 82°C [4].

4.2 Optimising the selected catalyst system

In this second stage, the exact level content of the “kicker” and “finisher” initiators to be added to each new resin was investigated. First, based in experience, testing and manufacturer recommendations minima and maxima levels for the content that initiators could be added to each new specific resin were established. The maxima and minima limits considered in this work for the content that any of the selected initiators might be added to each specific resin are summarised in Table 4.

Assuming these values a design of SPI gel testing experiments (DOE) at 82°C [4] was built by combining maximum and minimum values of the initiator contents settled for each new resin. Table 5 summarise results obtained from this collection of tests.

Thus, obtained results were analysed in order to minimise the gel and curing times in the case of the isophthalic and bisphenolic polyesters and vinylester resins, respectively. By using these criteria the following catalyst systems were selected to produce the U200 GRP profiles:

- i) To add the maximum contents of both initiators (1.5% Peroxan[®] BP + 5% Peroxan[®] BP Pulver 50 w) to the isophthalic polyester Resipur[®] 5103. In such case, it will be expected to obtain values of 2.1 min and 178,9 °C as gel time and exothermal pic, respectively.
- ii) to use also the maximum contents of the initiators (2% of Trigonox[®] C+5% Peroxan[®] BP Pulver 50 w) in the bisphenolic polyester resin Atlac[®] 382. In such case, it will be expected to obtain values of 2.9 min and 193,5 °C as gel time and exothermal pic, respectively.
- iii) Finally, it was decided to use a catalyst system based on the application of 0,6% of Norox[®] TBPB + 1,2% of Andonox[®] Pulcat AW-PF to the vinylester resin Atlac[®] 580. In this case

it was decided not use the maximum content of the “kicker” Andonox[®] Pulcat AW-PF because of its large contribute to the exothermal pic increasing. By using this catalyst system it was expected to obtain values of 7,1 min and 135,79 °C as curing time and exothermal pic, respectively.

Thermosetting resin	Maximum and minimum initiator content (%)									
	“Kickers”				Finishers					
	Peroxan [®] PB-Pulver 50 W		Andonox [®] Pulcat AW-PF		Peroxan [®] PB		Trigonox [®] C		Norox [®] TBPB	
Min.	Max.	Min.	Max.	Min.	Max.	Min.	Max.	Min.	Max.	
Isophthalic polyester Resipur [®] 5103	2	5	-	-	1	1.5	-	-	-	-
Bisphenolic polyester Atlac [®] 382	2	5	-	-	-	-	1	2	-	-
Vinylester Atlac [®] 580	-	-	1.2	2.4	-	-	-	-	0.4	0.6

Table 4: Maximum and minimum content of initiators that could be added to each new resin

Resin	Catalyst system		Exothermal pic (°C)	Gel time (min)	Curing time (min)
	Kicker	Finisher			
Isophthalic polyester Resipur [®] 5103	2% Peroxan [®] BP Pulver 50 w	1% Peroxan [®] BP	182.3	4.2	-
		1.5% Peroxan [®] BP	184.9	3.8	-
	5% Peroxan [®] BP Pulver 50 w	1% Peroxan [®] BP	184.6	2.4	-
		1.5% Peroxan [®] BP	178.9	2.1	-
Bisphenolic polyester Atlac [®] 382	2% Peroxan [®] PB Pulver 50 w	1% Trigonox [®] C	183.6	6.4	-
		2% Trigonox [®] C	204.6	4.6	-
	5% Peroxan [®] PB Pulver 50 w	1% Trigonox [®] C	193.5	4.0	-
		2% Trigonox [®] C	198.7	2.9	-
Vinylester Atlac [®] 580	1.2% Andonox Pulcat AW-PF	0.4% Norox [®] TBPB	155.1	-	7.4
		0.6% Norox [®] TBPB	135.8	-	7.1
	2.4% Andonox Pulcat AW-PF	0.4% Norox [®] TBPB	164.3	-	6.4
		0.6% Norox [®] TBPB	172.5	-	5.8

Table 5: Curing variables obtained from the SPI Gel tests made with the selected catalyst system

4.3 Validating the optimised catalyst system

The validation of the previously optimised catalyst systems has been done in this third stage by repeating SPI gel tests at 82°C in accordance to the ASTM D 7029 – 04 standard. Table 6 compares the predicted gel and curing times and exothermal pics with the experimental results obtained from those tests made on four samples. This table also compares the curing results obtained for the new resins and respective catalyst system with those obtained for the orthophthalic polyester Resipur[®] 2208 already successfully used in the production of U200 GRP profiles. As can be seen, the results obtained seem to be similar to the expected ones, reliable and suitable to allow using the resins and respective catalyst systems selected on the production of the desired U200 GRP profiles.

5 OPTIMISING THE PULTRUSION PROCESS

The optimisation of the pultrusion process was achieved in order to manufacture the U200 GRP profiles in good conditions at maximum production rate. This was done by selecting three temperature range at the die entrance and end, measuring the temperature on the produced profile at the die exit, its Barcol hardness and verifying if all the visual and dimensional level of defects observed on the final manufactured U200 profiles were in accordance with the requirements and tolerances imposed by the

European Standard EN 13706-2: 2002 .

Resin	Catalyst system	Exothermal pic (°C)		Gel time (min)		Curing time (min)	
		Predicted	Experim.	Predicted	Experim.	Predicted	Experim.
Orthophthalic polyester Resipur® 2208	2% Peroxan®PB Pulver50w + 1% Peroxan®PB	-	169.2 ± 2.0	-	2.4 ± 0.1	-	2.7 ± 0.1
Isophthalic polyester Resipur® 5103	5% Peroxan®PB Pulver50w + 1.5% Peroxan®BP	178.9	193.0 ± 5.5	2.1	2.0 ± 0.4	-	2.8 ± 0.3
Bisphenolic polyester Atlac® 382	5% Peroxan®PB Pulver50w + 2% Trigonox® C	193.5	189.6 ± 25.3	2.9	3.0 ± 0.3	-	3.8 ± 0.1
Vinylester Atlac® 580	1.2% Andonox Pulcat + 0.6% Norox® TBPB	135.8	140.2 ± 1.8	-	5.1 ± 0.6	7.1	6.7 ± 1.6

Table 6: Comparison between predicted and experimental results of the optimised catalyst systems

Monitoring the temperature on the profile at the die exit it is a good measure of the degree of cure achieved. Temperatures on the profile higher than the ones in the die means cure it was not complete done inside of the die. The Barcol hardness measured on the profile is another good indicator of the degree of cure reached. According to EN 13706-2: 2002 standard and experience Barcol hardness values lower than 80% of the figures given by the resin manufacturer means uncured profiles that should be rejected or subject to post-cure treatment.

Table 7 summarises the results obtained for the profiles produced with the different resins and selected catalyst systems. In the table, the terms “Good” and “No” in the line correspondent to “Visual and dimensional defects” means the profile accomplished or not accomplished the requirements of the EN 13706-2: 2002 standard. From the results obtained it was concluded to produce the U200 GRP profiles in the following pultrusion conditions:

- Using the orthophthalic polyester Resipur® 2208 as matrix: 140 °C and 130 °C as temperatures of die entrance and exit, respectively, at the pull speed of 400 mm/min.
- Using the isophthalic polyester Resipur® 5103 as matrix: 140 °C and 130 °C as temperatures of die entrance and exit, respectively, at the pull speed of 300 mm/min.
- Using the bisphenolic polyester Atlac® 382 as matrix: 140 °C and 130 °C as temperatures of die entrance and exit, respectively, at the pull speed of 200 mm/min.
- Using the vinylester Atlac® 580as matrix: 160 °C and 150 °C as temperatures of die entrance and exit, respectively, at the pull speed of 200 mm/min.

5 TESTING THE U200 PRODUCED PROFILE

Finally, the pultruded U200 GRP profiles based on the orthophthalic matrix were submitted to the batch of mechanical tests defined in the EN 13706-2: 2002 to verify their accordance to the requirements of that European Standard. Table 8 shows the results obtained from those tests and compares them with the standard requirements.

As may be seen from this table the profiles accomplished with almost all mechanical requirements of the standard and presented characteristics in good agreement with theoretical predicted values, with exception of the flexural strength in the transversal direction where a value lower than the required one was obtained. From this last result as well as from the experimental result for the transversal tensile modulus that was very similar to the required one seem to denote the necessity of enhance a little bit more the mechanical properties of the profile in its transversal direction. This could be easily done by include two more glass plain fabric layers in the profile laminate.

		Pultrusion Conditions									
		140				150			160		
		130				140			150		
		200	300	400	500	300	400	500	200	300	400
Resin	Property										
Orthophthalic polyester Resipur® 2208	Temperature at die exit	-	-	118.2 ± 1.1	128.5 ± 2.4	-	-	133.4 ± 1.1	-	-	-
	Barcol hardness	-	-	65.7 ± 2.7	66.6 ± 2.3	-	-	67.2 ± 2.0	-	-	-
	Visual and dimensional defects	-	-	Good	No	-	-	No	-	-	-
Isophthalic polyester Resipur® 5103	Temperature at die exit	-	112.1 ± 0.9	117.8 ± 1.6	124.2 ± 1.2	-	155.3 ± 2.5	-	-	-	-
	Barcol hardness	-	62.1 ± 1.8	64.1 ± 2.5	63.8 ± 3.0	-	64.3 ± 1.9	-	-	-	-
	Visual and dimensional defects	-	Good	No	No	-	No	-	-	-	-
Bisphenolic polyester Atlac® 382	Temperature at die exit	111.0 ± 1.1	-	-	-	123.6 ± 0.9	129.3 ± 2.5	-	-	-	-
	Barcol hardness	61.5 ± 3.0	-	-	-	60.0 ± 2.6	-	-	-	-	-
	Visual and dimensional defects	Good	-	-	-	No	No	-	-	-	-
Vinylester Atlac® 580	Temperature at die exit	-	-	-	-	-	-	-	116.3 ± 2.1	123.3 ± 2.4	129.2 ± 2.2
	Barcol hardness	-	-	-	-	-	-	-	67.9 ± 2.1	65.8 ± 2.1	-
	Visual and dimensional defects	-	-	-	-	-	-	-	Good	No	No

Table 7: Summary of results obtained in the tests to optimise pultrusion processing conditions

Property	Unit	Test method	Minimum required values	Experimental obtained values	Theoretical predicted values
Elastic modulus in a full section flexural test	GPa	Annex D, EN 13706-2	23	27.5 ± 3.4	27.7
Tensile modulus, axial direction (coupon test)	GPa	EN ISO 527-4	23	32.7 ± 1.8	27.7
Tensile modulus, transversal direction (coupon test)	GPa	EN ISO 527-4	7	7.0 ± 0.2	9.0
Tensile strength, axial direction (coupon test)	MPa	EN ISO 527-4	240	369.4 ± 16.9	-
Tensile strength, transversal direction (coupon test)	MPa	EN ISO 527-4	50	59.8 ± 4.0	-
Pin-bearing strength, axial direction (coupon test)	MPa	Annex E, EN 13706-2	150	200.1 ± 1.8	-
Pin-bearing strength, transversal direction (coupon test)	MPa	Annex E, EN 13706-2	70	202.4 ± 1.7	-
Flexural strength, axial direction (coupon test)	MPa	EN ISO 14125	240	617.3 ± 16.9	-
Flexural strength, transversal direction (coupon test)	MPa	EN ISO 14125	100	78.2 ± 9.5	-
Interlaminar shear strength, axial direction (coupon test)	MPa	EN ISO 14130	25	28.1 ± 0.4	-

Table 8: Minimum mechanical properties required for profiles of the E23 grade of EN 13706 -3

6 CONCLUSIONS

A study concerning the production of a U200 GRP profile by pultrusion was developed in this work. A die was designed and manufactured and all processing conditions optimised. The production of the profile using four different matrices was also studied and the catalyst system for three new matrices established by using SPI gel tests.

The laminate of the GRP profiles to be produced was also designed to accomplish all production and market requirements, such as those established for the grade E23 of the European Standard EN 13706 : 2002.

Finally, produced profiles were also submitted to mechanical testing to verify their accomplishment to all requirements of the above mention European standard. In spite of the good results obtained and their good agreement with the theoretical predicted ones it was verify to be necessary to enhance a little bit more the transversal properties of the U200 GRP profile by introducing two more layers of glass fibre plain fabric in the laminate

ACKNOWLEDGEMENTS

Authors wish to thank Portuguese Foundation for Science and Technology (FCT) for the financial support of IPC through project UID/CTM/50025/2013. They also have to acknowledge all institutional, infrastructural and logistics support received from Vidropol SA during all work carried out.

REFERENCES

- [1] D. Melo, *Studying and optimising the introduction of new raw materials in the production of composite pultrusion profiles*”, MSc Thesis, Minho University, November, 2014.
- [2] *Reinforced plastics - Specifications for pultruded profiles*, European Standard EN 13706 Part 1, 2 and 3, 2002.
- [3] T. F. Starr, *Pultrusion for engineers*, Woodhead Publishing Lt., Cambridge; England, 2000.
- [4] *Standard Test Method for Determination of Reactivity of Unsaturated Polyesters and Vinyl Esters at 180.0F [82.2°C]*, ASTM D7029 – 09, 2009.
- [5] Software SOLIDWORKS®, www.solidworks.com (visit on 2015/04/29)
- [6] X.-L.Liu, Numerical Modeling on pultrusion of composite I beam. Elsevier, 2001. *Composites: Part A*, **32**, 2001, pp. 663-681.
- [7] Quinn, J.A., *Composites - Design Manual*, Liverpool, UK: James Quinn Associates Ltd, 1998.
- [8] Harris, H., *Engineering Composite Materials*, The Institute of Materials, London, 1999.
- [9] Jones, R.M, , *Mechanics of Composite Materials*, McGraw-Hill, New York, 1975.
- [10] Hull, D., *An Introduction to Composite Materials*, University Press, Cambridge, 1981