

# An overview of the Quality of Service in Bluetooth Communications in Healthcare

Ana Pereira<sup>1</sup>, Eliana Pereira<sup>1</sup>, Eva Silva<sup>1</sup>, Tiago Guimarães<sup>1</sup>, Filipe Portela<sup>2</sup>, Manuel Filipe Santos<sup>2</sup>, António Abelha<sup>2</sup>, José Machado<sup>2</sup>

<sup>1</sup>University of Minho, Portugal, <sup>2</sup>Algoritmi Research Centre, University of Minho, Portugal  
{a58539, a58508, a60196, a61774}@alunos.uminho.pt,  
{cftp, mfs}@dsi.uminho.pt, {abelha, jmac}@di.uminho.pt

**Abstract.** Currently, the general public requires devices getting faster and great performance, that is, devices ensuring a better quality of service. One way to achieve these goals is through the use of devices supported by the mobile computing with tools to help the search for information. Bluetooth technology is an open standard for wireless communication allowing the transmission of data and information between electronic devices within walking distance, with minimum resource expenditures, safe and rapid transition of data. So, the Bluetooth technology was initially designed to support simple network devices and personal devices such as mobile phones, PDAs and computers, but quickly it were discovered other applications in several areas. In this article, it will be performed a literature review on the topic, with the goal to understand how the Bluetooth technology can benefit increases in the Quality of Service and the presentation of some actual and potential biomedical applications.

**Keywords:** Bluetooth, Quality of Service, Piconets, Master, Slave, Heal, Biomedical applications, Ubiquitous Devices

## 1 Introduction

The Bluetooth technology is considered a low power technique, low cost and secure. It consists of a wireless communication technology, specially designed to replace the wires that interconnect and ubiquitous electronic devices that are relatively next, such as mobile phones or dial-up network. In addition, also fits printers, keyboards, headsets, and etc. To date, it has been considered a Personal Area Network (PAN) for ad-hoc and network infrastructure [1]. More now than ever, with the release of the Core Specification 4.x, including the single-mode Bluetooth low-energy (BLE) technology or Bluetooth Smart) and dual-mode (both classic Bluetooth and BLE combined) or Bluetooth Smart ready, Bluetooth is a leading candidate to connect the Internet of Things.

The Bluetooth specification defines a radio frequency interface and a set of communication protocols for the discovery of devices, data exchange and bug fixes. By the other hand, the connection speed, communication range and the level of Bluetooth transmission also are chosen. So, Bluetooth is considered a low cost and consumption technology and thus has quickly become one of the most interesting technologies for communication within small distances. However, problems related with the Quality of

Service (QoS) should be treated in order to ensure that these requirements are met by the system components of communication during data transmission. In networks without wire, the complexity increases to meet these requirements due to the high dynamics of the environment and the diversity in the quality of the links, caused mainly by the interference by high error rates and the mobility of users.

Commonly, in health units, mobile devices are relatively close to each other and usually around the patient. In this sense the main propose of this article is to understand how the Bluetooth technology can benefit the increase of QoS in a real context in a health institution (Centro Hospitalar do Porto). In this paper, a review of literature on the subject will be held in order to understand how Bluetooth technology can increased QoS in health institutions, patient recovery and their wellbeing. Thus, this study is the start point of a project that is being developed in the CHP institution, whose purpose is to introduce wireless communication between various devices attached to patient recovery, thereby improving QoS.

## **2 Background**

### **Centro Hospitalar of Porto and AIDA**

In Centro Hospitalar of Porto (CHP) sometimes the existence of many devices connected to the patient and the existence of wires becomes uncomfortable for the patient and for their recovering. In this sense the goal of this study is to understand how the Bluetooth technology can be a benefit by increasing the QoS at CHP and the overall quality patient life. In the case of CHP is implemented the (Agency for Integration, Archive and Diffusion of Medical Information). This is a platform based on multi-agent system. The main goal is to overcome the difficulties presented by the uniformity of clinical systems and by the complexity of medical and administrative data provided by different hospital data sources [2–4]. In addition and in this context, the AIDA emerges as one example of the technologies that may benefit from the full capabilities of Bluetooth and its subsequent increase of QoS [5].

### **The Bluetooth technology**

In the Bluetooth Core Specification version 4.0, the Bluetooth Special Interest Group (SIG), included, not only the well-known and widely used Classic Bluetooth (BT) but also the Bluetooth Smart or Bluetooth Low-Energy (BLE) introducing a brand new way of allowing the existence of a new generation of devices that can run for months without a recharge [15]. However, this has important limitations as well as benefits. It is quite different from Classic Bluetooth technology—so different that must carefully be considered which technology best fits the application needs [16]. Bluetooth is a set of specifications for common short-range wireless applications. These specifications include core components, and the application profiles that use them. These specifications are rigorously validated by the Bluetooth SIG before they are adopted and published and that these specifications are tested and qualified to ensure interoperability [15].

With the introduction of Bluetooth low energy technology, there has been considerable interest in its possibilities regarding many aspects present in the daily aspects of the users' life. It was born to allow the existence of small and simple devices that can be peripherals for smartphones and other devices, these are called Bluetooth smart devices. The main devices in which they are connected are called Bluetooth Smart Ready devices. Bluetooth Smart devices include only a single-mode low energy Bluetooth v4.0 radio. This Bluetooth Smart Ready devices are able to connect to both BT and BLE implementing a Bluetooth v4.0 dual mode radio, where Bluetooth low energy functionality is integrated into an existing Classic Bluetooth controller.

BLE features a very efficient discovery and connection set-up, short data packages, and asymmetric design for battery operated sensor types of applications. As with Classic Bluetooth technology, Bluetooth low energy technology is based on a master connected to a number of slaves. However, in Bluetooth low energy technology the number of slaves can be as big as the implementation and available memory allows it to be. The new advertising functionality makes it possible for a slave to announce that it has something to transmit to other devices that are scanning. Advertising messages can also include an event or a measurement value.

There are also differences in software structure (Fig. 1). In Bluetooth low energy technology all parameters have a state that is accessed using the attribute protocol. Attributes are represented as characteristics that describe signal value, presentation format, client configuration, etc. The definitions of these attributes and characteristics along with their use make it possible to build several basic services and profiles like proximity, battery, automation I/O, building automation, lighting, fitness, and medical devices. All these nuances are needed to assure the implementation is compatible between devices from different manufacturers. While Bluetooth 2.0 EDR or Bluetooth 3.0 HS introduced a higher data rate functionality, Bluetooth 4.0 targets effective communication with devices that do not need streaming data or high data throughput. Low-energy requirements stipulate noticeable differences in Bluetooth and Bluetooth LE protocols, but at the same time take great advantage in reuse of the RF part, leaving most of the changes to the protocol stack [15, 18].

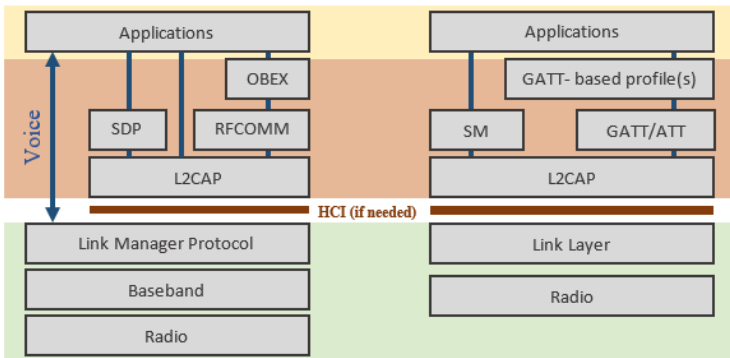

Fig. 1. - A simplified version of the Classic Bluetooth and the BLE protocols.

Although having some common layers, some major changes can be observed by the extinction and the rise of some parts and by the adjustment of others. Even though both have a radio layer, which promotes modulation and demodulation the physical layer signal, they are not the same. The frequency range is the same (in the 2.4 GHz band), they both use frequency hopping, and the modulation scheme is also equal (Gaussian Frequency Shift Keying (GFSK) modulation), however the modulation index is different (0.5 in BLE and 0.35 in BT). This change lowers power consumption and also improves the range of BLE versus Classic Bluetooth [6, 18]. The Classic Bluetooth includes a Baseband layer that transmits the packets directly and supports two types of links: Synchronous Oriented Connection (SCO) and Asynchronous not Oriented Connection (ACL). The SCO link has characteristics that can be found in circuit switching, while the connection ACL is more akin to packet switching. Includes additionally the LMP (Link Manager Protocol) that provides the basic functions for configuration and management ACL links. In Bluetooth LE is present the link layer (LL) controller which is responsible for low level communication over a PHY interface. It manages the sequence and timing of transmitted and received frames, and using a link layer protocol, communicates with other nodes regarding connection parameters and data flow control. It also handles frames received and transmitted while the device is in advertising or scanner modes. It also provides gate keeping functionality to limit exposure and data exchange with other devices. If filtering is configured, the LL controller maintains a “white list” of allowed devices and will ignore all requests for data exchange or advertising information from others. It not only helps with a security aspect but also reduces power consumption. Uses HCI to communicate with upper layers of the stack if they are not collocated [6, 18]. In both implementations can be found the HCI (host controller interface) layer that acts as a boundary between the lower layers of the Bluetooth protocol stack and the upper layers.

The Bluetooth specification defines a standard HCI to support Bluetooth systems that are implemented across two separate processors. For example, a Bluetooth system on a computer might use a Bluetooth module’s processor to implement the lower layers of the stack but then use its own processor to implement the upper layers. In this scheme, the lower portion is known as the Bluetooth module and the upper portion as the Bluetooth host. However it is not required to divide the Bluetooth stack in this way. Some devices can combine the module and host portions of the stack on one processor, being this intended for small and self-contained devices. In such devices, the HCI may not be implemented at all unless device testing is required. The logical link control and adaptation layer protocol (L2CAP) component provides data services to upper layer protocols. It is responsible for protocol multiplexing data between different higher layer protocols and Segmentation and reassembly of packets, and de-multiplexing and reassembly operation on the other end [6, 18]. The upper layers are another aspect that marked a difference among the BT and the BLE. They consist of protocols allowing to discover services provided by other Bluetooth devices in the surrounding area of the device, and making sure it is done safely and efficiently. The Security manager in BLE and RFCOMM and OBEX in BT are examples of these layers. Bluetooth 4.0 introduces

also a new communication method, called the attribute protocol (ATT) which is optimized for small packet sizes used in Bluetooth low energy. The ATT allows an attribute server to expose a set of attributes and their associated values to an attribute client. These attributes can be discovered, read, and written by peer devices.

The generic attribute profile (GATT) describes a service framework using the attribute protocol for discovering services, and for reading and writing characteristic values on a peer device. It interfaces with the application through the application's profiles. The application profile itself defines the collection of attributes and any permission needed for these attributes to be used in the communication [18].

### 3 Quality of Service

#### Concept

The concept of QoS has evolved over time. Initially, the only concern was the ability to maintain communication between devices and subsequently the error occurrence and packet loss during the process of communication. Later on, the need to take into attention issues such as congestion control of the network and the service differentiation [8]. The QoS parameters can be negotiated between the user and the network for each communication session, depending available resources and QoS requirements. However, providing a QoS guarantee implies that the performance of the network is consistent and predictable, which can be a major challenge [8].

#### Affecting factors

The application layer QoS is affected by the width bandwidth, the delay, the delay variant, the error rate, the likelihood of loss, etc. For each parameters can be set the limits of variation. The factors that affect the QoS are related, not being able to improve a parameter without adversely change another [6]. Then, it is listed the most important parameters to obtain the QoS:

1. **Bandwidth:** For an application to run properly, it is needed a certain bandwidth Bluetooth connection, wherein the available bandwidth influences delays obtained data transfer. An application can explicitly specify the bandwidth needs or the bandwidth can be derived the application requirements for the delays. This one parameter is mostly determined by the algorithms polling performed by the master of the piconet [6].
2. **Delay and delay variation:** This parameter is caused by the available bandwidth and the retransmissions. The SCO traffic has priority over traffic ACL, so you can also contribute to delays in the ACL traffic. The delay-sensitive applications such as real-time applications and audio/video applications require few delays [6].
3. **Reliability:** All applications prefer that the data arrives in the correct order, however, some applications are more error tolerant than others. In general, applications audio/video can tolerate some errors, while application data, such as an HTTP request or email, require that the data arrives in the correct order. Increasing this parameter results in a decrease in bandwidth and hence an increase the delay [6].

## 4 Biomedical applications

The main action of QoS in communication and networks is present among some factors that occur in the end systems, such as the delay end-to-end, the package loss, the variation in the delays as well as the throughput. The application of the QoS in these systems WLAN, as Bluetooth, can result in a higher efficiency of the system and a better applicability. Nowadays, Bluetooth can be applied in several biomedical applications, such as, sensors in hospitals and in patients' houses (live assistance 24 hour / day). These mechanisms begin to have a higher relevance, because, with the population aging, an increase of diseases such as cardiovascular diseases, diabetes, and Alzheimer's disease, among many others, is expected. These diseases demand a certain supervision performed by the healthcare professionals and increase the costs associated with the healthcare [10,17].

The use of devices or applications that rely on Bluetooth have much to offer to assist in this problem. Some examples of technologies that rely on the use of Bluetooth are described below. A biomedical application using Bluetooth, in order to have a higher control on a person's weight based on easy-of-use mechanism allows the self-control of the person's weight was developed [11]. The device created is composed by a monitor that implements an auto-monitoring system using a Bluetooth network, allowing a weight control. It is presented a prototype of the system but until now there were not performed tests in order to evaluate the system applicability as a personal health control unity. A low power A/D converter and it uses wireless networks, to make integration with other technologies or infrastructures easier and less expensive. This system is composed by two processors, the Bluetooth and the FPGA (Field-Programmable Gate Array), being these submersed in a solution. The developed system allows to convert an analogue signal that simulates an electrocardiogram (ECG) signal. This device works with a remote computer that processes data sent by Bluetooth. The test results with this system proved that it is possible to make a continual ECG signal transmission without information losses [12]. A biomedical application that monitors a person's health status in a daily basis. This application uses Bluetooth network that limits the system capacity to a small number of parameters. A prototype composed by a pulse clock sensor connected to a PDA (Personal Digital Assistant) was developed. The connection is made by Bluetooth. The system is also equipped with several components such as accelerometers and thermic sensors made by GSR (Galvanic Skin Reflex) electrodes. The Bluetooth module makes possible the connection between the PDA and a monitor allowing the health status evaluation of the person as well as is movements and behaviors. This way, the information acquired by the sensor allow to guide the person in real-time, giving him a self-control of its health [14]. A system for remote medical assistance of recovering infarct patients was also created [14]. These systems is implemented in some hospitals and it uses a Bluetooth connection to send data recorded by portable ECG recorders to mobile devices such as mobile phones. The data are then sent to a central unit implemented in a Web server where a database is implemented. The database organizes the information about the ECG and relevant clinical data about the patient, allowing a better access to the cardiologist. This way, it is possible to make a better motorization of the patient's health status.

## **5 Critical analysis**

Besides wireless networks, such as Bluetooth, having mobility as an advantage, sometimes this advantage introduces difficulties in the system that are not present in other networks. These difficulties are, for example, the quality of the wireless transmission, the great variability of the connection quality, the reduced bandwidth and the highly dynamic network topology, that allows the direction of the elements between the source and the end. Therefore, wireless networks require a more sophisticated QoS management. One of the requirements of this technology is to maintain the simplicity. Thus, the Bluetooth technology must continue to be a simple and low cost technology and the QoS must be as simple as possible, while responding to the applications needs. The QoS implementation should not result in a significant cost and energy consumption increase, because the demands to processing capacity, memory capacity and energy consumption must be limited. One of the disadvantages of this technology is that, if two slaves want communicate among themselves, they must do it through the master. Another disadvantage is related with the existence of delays and unavailability when the connection as interferences. It is important to mention that the QoS parameters should be defined as an extension of the actual Bluetooth specifications.

In the biomedical field, the implementation of the QoS results in a better efficiency of the Bluetooth, and consequently, increases the efficiency of the applications associated with this technology. For example, in the remote ECG it is demanded an almost null packet loss, because it is not plausible the presentation of a patient's ECG signal with losses. Bluetooth can be an important technology in the Pervasive Information fields and in the way of the systems communicates with ubiquitous devices.

## **6 Conclusions**

In communication networks, the traditional vision of QoS is concerned with the end-to-end delay and its variation, packet loss and the provided bandwidth. Bluetooth devices communicate among themselves and form a network called a piconet, with one the master, and the others, the slaves. With the Bluetooth communications evolution, the users of this technology are becoming more demanding. Thus, it is necessary to develop mechanisms enabling the delivery of quality services that comply with the QoS parameters required by the users. Finally, this study provides a starting point for the construction and implementation of devices using Bluetooth technology in healthcare in order to increase the QoS in health institutions. It is an important asset to who wants to research in this area and did not have an idea how is application of Bluetooth in healthcare institutions.

## **7 Acknowledgements**

This work has been supported by FCT - Fundação para a Ciência e Tecnologia within the Project Scope UID/CEC/00319/2013.

## 8 References

1. U. Bilstrup, K. Sjöberg, B. Svensson, and P.-A. Wiberg, "A fault tolerance test enabling QoS in a Bluetooth piconet," 2004, pp. 33–36.
2. Abelha, António. et al. , "Agency for Archive, Integration and Diffusion of Medical Information. Proceeding of AIDA.," 2003.
3. L. Cardoso, F. Marins, F. Portela, M. Santos, A. Abelha, and J. Machado, "The next generation of interoperability agents in healthcare.," *Int. J. Environ. Res. Public Health*, vol. 11, no. 5, pp. 5349–71, May 2014.
4. H. Peixoto, M. Santos, A. Abelha, and J. Machado, "Intelligence in Interoperability with AIDA," in *Foundations of Intelligent Systems SE - 31*, vol. 7661, L. Chen, A. Felfernig, J. Liu, and Z. Raś, Eds. Springer Berlin Heidelberg, 2012, pp. 264–273.
5. A. Ganz, Z. Ganz, and K. Wongthavarawat, *Multimedia Wireless Networks: Technologies, Standards and QoS*. Pearson Education, 2003.
6. M. van der Zee and G. Heijenk, "Quality of Service in Bluetooth networking - part I," no. TR-CTIT-01–01. University of Twente, Centre for Telematics and Information Technology (CTIT), Enschede, the Netherlands, 2001.
7. A. B. Soares, "Análise da Qualidade de Serviço de VPN – Redes Privadas Virtuais - Utilizando Redes Sem Fios," 2014.
8. R. L. Aguiar and L. Brito, "Qualidade de Serviço em redes móveis: presente e futuro," in *Conf. Científica e Tecnológica em Engenharia - CCTE*, 2002, vol. 1, p. 1.
9. T. Wu, C. Ke, C. Shieh, and W. Hwang, "A Practical Approach for Providing QoS in Bluetooth Piconet," pp. 332–338.
10. R. Latuske and A. R. S. S. Gmbh, "Bluetooth Health Device Profile and the IEEE 11073 Medical Device Frame Work Bluetooth in Medical Applications," pp. 1–6.
11. J. Parkka, M. van Gils, T. Tuomisto, R. Lappalainen, and I. Korhonen, "A wireless wellness monitor for personal weight management," in *Information Technology Applications in Biomedicine, 2000. Proceedings. 2000 IEEE EMBS on*, 2000, pp. 83–88.
12. J. Lönnblad, M. Ekström, A. Fard, J. G. Castaño, and T. Johnson, "Remote System for Patient Monitoring Using Bluetooth," in *IEEE International Conference on Sensors*, 2002.
13. K. Ouchi, T. Suzuki, and others, "LifeMinder: a wearable healthcare support system using user's context," in *Distributed Computing Systems Workshops, 2002. Proceedings. 22nd International Conference on*, 2002, pp. 791–792.
14. S. Khor, J. Nieberl, K. Fugedi, and E. Kail, "Telemedicine ECG-telemetry with Bluetooth technology," in *Computers in Cardiology 2001*, 2001, pp. 585–588.
15. Volume 6 of the Bluetooth Core Specification, Version 4. Core System Package [Low Energy Controller Volume]. Issued on December 17th, 2009.
16. Gomez, C., Oller, J., & Paradells, J. (2012). Overview and evaluation of bluetooth low energy: An emerging low-power wireless technology. *Sensors*,12(9), 11734-11753.
17. Omre, A. H., & Keeping, S. (2010). Bluetooth low energy: wireless connectivity for medical monitoring. *Journal of diabetes science and technology*, 4(2), 457-463.
18. Bluetooth low energy – White Paper - LitePoint, 5 Feb 2015  
[http://www.litepoint.com/whitepaper/Bluetooth%20Low%20Energy\\_WhitePaper.pdf](http://www.litepoint.com/whitepaper/Bluetooth%20Low%20Energy_WhitePaper.pdf)
19. Bisdikian, C. (2001). An overview of the Bluetooth wireless technology. *IEEE Commun Mag*, 39(12), 86-94.