

# Hybrid Composite Plates (HCP) for Shear Strengthening of RC Beams

E. Esmaeeli<sup>1</sup>, J.A.O. Barros<sup>2</sup>, H. Baghi<sup>3</sup>

<sup>1</sup> PhD Candidate, Dep. Civil Eng., Minho University, Guimarães, Portugal, [esmaeeli@civil.uminho.pt](mailto:esmaeeli@civil.uminho.pt)

<sup>2</sup> Full Prof., Dep. Civil Eng., Minho University, Guimarães, Portugal, [barros@civil.uminho.pt](mailto:barros@civil.uminho.pt)

<sup>3</sup> PhD Student, Dep. Civil Eng., Minho University, Guimarães, Portugal, [hadibaghi@gmail.com](mailto:hadibaghi@gmail.com)

**Keywords:** Strain Hardening; CFRP sheet; Shear Strengthening; Deep Beam.

## SUMMARY

*The potential of a hybrid composite plate (HCP) for the strengthening of reinforced concrete (RC) deep beams is evaluated. HCP are composed of a CFRP sheet that is glued to the external surface of a thin plate made of strain hardening cementitious composite (SHCC). These panels were glued to the lateral faces of RC deep beams. Three groups of shear strengthened RC beams were tested under three-point bending load configuration. CFRP sheet, SHCC plate or HCP were individually applied to the lateral faces of shear deficiently reinforced beams to compare the effectiveness of these different strengthening schemes. The load-mid span deflections of these beams are compared to the response of the control beam. The maximum load carrying capacity and its corresponding mid-span deflection, crack pattern and the initial flexural stiffness are the studied parameters.*

## 1. INTRODUCTION

When shear span ( $a$ ) to the effective depth of the beam ( $d$ ) ratio is less than 2 or when the clear span of the beam ( $l$ ) to the depth of the beam's cross section ( $h$ ) ratio is less than 4, ACI318-05 categorizes these structures as deep beams [1]. A compressive strut forms between the loading point and the supports that is the main load resisting mechanism for these beams. If this compressive strut is crossed by steel stirrups, they can support the tensile stresses developed orthogonally to the direction of this strut, and the tensile resisting mechanism of these stirrups also enhances the ductility of this region. The coupling beams of shear walls, transfer girders, bent cap of the bridges are examples of such structures. The need to the strengthening of these beams mainly arises due to the change in their loading demands, deterioration caused by the aggressive environmental conditions or deficiency in their original designing process.

Among the few studies available in the literatures, the fiber reinforced polymer (FRP) composite found as the more advance and feasible shear strengthening technique [2, 3]. However, deficiencies correlated to the use of resin-based adhesives as bonding agents made the CFRP system vulnerable against vandalism and environmental exposure such as high temperature and humidity [4-7]. The possibility of using mechanical fasteners requires special FRP systems in order to support the stress concentration caused by anchorage devices [8].

Strain hardening cementitious composite (SHCC) is a more advance version of ordinary fiber reinforced concrete (FRC) with the characteristic of developing a tensile load carrying capacity that increases in post cracking regime. This behavior is followed by the formation of multiple diffused cracks through all the loaded length of the specimen, assuring much higher ductility than FRCs. After the composite has reached its ultimate load, the load follows a softening branch, Figure 1. One of the earliest versions of the ultra ductile SHCC was engineered by mixing only 2% in volume of short Poly

Vinyl Alcohol (PVA) fibers in a fine graded cementitious matrix. The tailored composite was nominated as Engineering Cement Composite (ECC) with a tensile strength in the range of 3 to 6 MPa and a tensile strain capacity up to 6% [9-11]. In the recent years, SHCC has successfully used as both construction and retrofitting materials, for example: composite steel/ECC deck for a cable-stayed bridge, repair of a Dam in Japan[12], bridge deck retrofit [13], and retrofitting layer for masonry structures [14].

In this paper the structural effectiveness of prefabricated SHCC plates combined with carbon fiber reinforced polymer (CFRP) sheets for the shear strengthening of deep beams is investigated. This strengthening technique is nominated as hybrid composite plate (HCP). The main objective of covering the CFRP with the SHCC plate, in the durability perspective, is to provide a protective layer for the CFRP systems, adding an extra safety against the detrimental effects of vandalism, and cycles of relatively high humidity and temperature. In terms of mechanical behavior, the SHCC contributes to increase the resistance of the compressive strut, and to restrain the propagation of cracks due to the fiber reinforcement mechanisms, being expectable a significant increase in terms of load carrying capacity and deformation performance. Also by applying the ECC panel against to the CFRP sheet with a certain pressure, the bond conditions of this composite system can be improved, since more uniform thickness of the epoxy resin can be achieved with a minimum content of voids. It is also supposed that the SHCC plate brings the potential of using the mechanical anchorages, a topic that is being investigated.

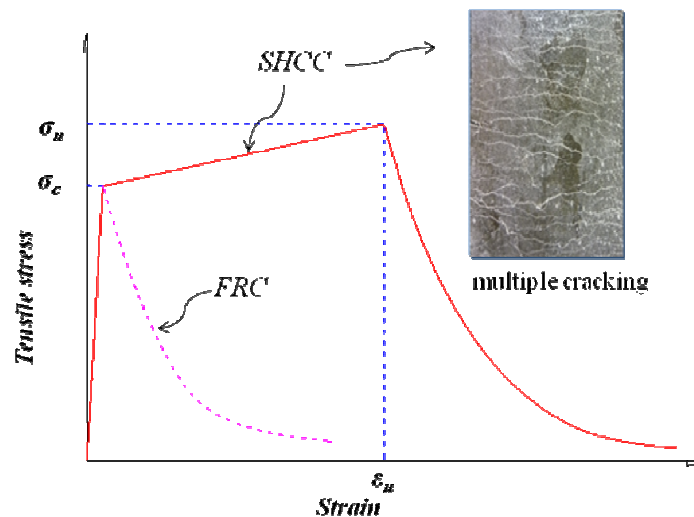

Figure 1: Typical tensile stress versus strain response for SHCC and FRC

## 2. EXPERIMENTAL PROGRAM

To assess the efficiency of the HCP for the shear strengthening, ten reinforced concrete (RC) beams with dimensions of 150 mm × 150 mm × 600 mm were fabricated. Depending on the number of the steel stirrups applied, these beams were categorized in two different types as shown in Figure 2. Type “A” with minimum shear reinforcement, according to ACI318-05 [1], and type “B” with only two steel stirrups in the alignment of the beam’s supports and with the purpose of maintaining the longitudinal rebars in its target position.

While beams of type “A” were considered as control beams, the other beams were strengthened by the means of attaching CFRP sheets, SHCC plates or HCP on the lateral faces of these beams. Both types of the beams were subjected to three-point bending test and the results of these tests were used to discuss the efficiency of the shear strengthening provided by HCPs.

### 2.1. Preparation of the specimens

As Table 1 and Figure 3 show, the designation “CB” was attributed to the beams of type “A”. Depending on the strengthening technique adopted, the beams of type “B” were divided in following

three groups. “BF” beams that were continuously strengthened by externally bonded CFRP sheets by covering the lateral faces along the entire loading span. Through a wet layup technique, a layer of unidirectional carbon fabric was glued to the each side of the beams as the carbon fibers were oriented parallel to the longitudinal axis of the beam. S&P 50 epoxy resin was utilized as a bonding polymer to impregnate and attach the carbon fabric to the concrete beam. The second group of “B” type, designated as “BS”, consisted of four beams strengthened with a SHCC plate attached to each lateral face of the beams. These plates had overall dimensions of 18 mm × 150 mm × 500 mm and were bonded to the concrete beams by using S&P 50 epoxy resin. The last group of "B" type beams, designated as “BH”, was used to assess the effectiveness of combining a CFRP sheet with a SHCC plate. The resulting system has the designation of HCP plate, and this type of plate was applied in each lateral faces of these beams. The execution of a HCP plate is composed of the following steps: a layer of carbon fabric was applied to each lateral side of the concrete beam by means of wet layup technique and using S&P 50 epoxy resin; the internal surface of the SHCC plate (to be bonded to the CFRP sheet) was saturated with the same epoxy resin and pressed against the CFRP sheet (mechanical clamps were used to maintain this plate pressed against the lateral surface of the concrete beam up to the time that the epoxy resin developed its initial bond) It should be noted that all the process has been done during the gel time of the resin epoxy; after 24 hours, the same process was followed to install an HCP to the other lateral face of the beams. In the series BF and BH the fibers of the CFRP sheet coincide with the longitudinal axis of the beams. The authors are aware that this is not the most favorable orientation for the shear strengthening, but it was purposely selected in order to evidence the benefits of the SHCC plate.

The SHCC plates were cut from bigger panels with a size of 490×500×20 mm<sup>3</sup> and then the bottom side of them was grinded for about 2 mm to obtain a flat surface. Four panels were produced by casting the prepared SHCC inside the acrylic moulds. For the casting purpose, a standard slump cone which was placed in the center of the mould was used. The composite was flowed homogenously, and a circular shape was maintained until reaching the extremities of the mold. Since the rheological characteristics of the developed SHCC were tailored to have self consolidating requisites, the corner of the mould was easily filled up without the need to any external vibration. Each panel was built with a batch of composite of around five liters, and this filling process of the mould was applied to all the panels.

Just after the panels have been cast, they were sealed with a plastic sheet and were kept in a room temperature during 24 hours before de-molding, in order to prevent loss of hydration moisture in the early age. After de-molding, all the specimens were transferred to a climate room and were cured in a constant temperature equal to 20° C and relative humidity of 85% up to the age of 28 days. These curing conditions were found to be the most efficient to assure to the SHCC the highest tensile strength with a tightest crack width [15]. Two specimens from each panel were also extracted to characterize the tensile behavior of the developed SHCC.

**Table 1:** Series of beams and the strengthening techniques of the experimental program

<i>Beam Type</i>	<i>Designation</i>	<i>Strengthening technique</i>	<i>Number of the tested specimens</i>
A	CB	N/A	2
	BF	CFRP	2
B	BS	SHCC Plate	4
	BH	HCP* (SHCC plate + CFRP)	2

\*Combination of SHCC plate and CFRP

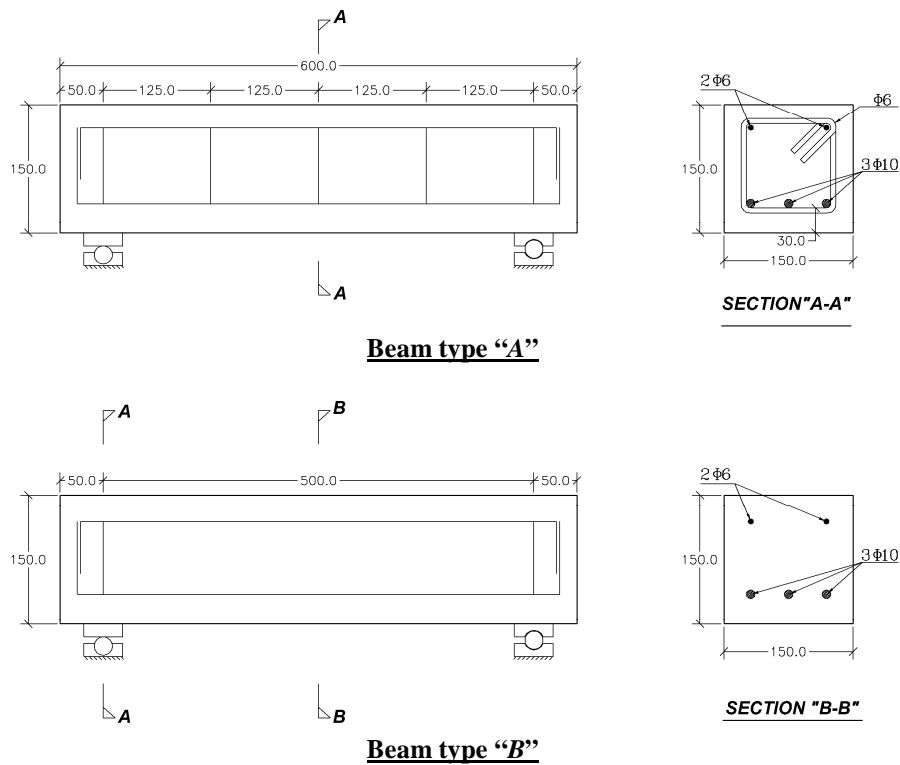

**Figure 2:** Geometry and reinforcement arrangements of concrete beams of the experimental program (dimensions in mm)

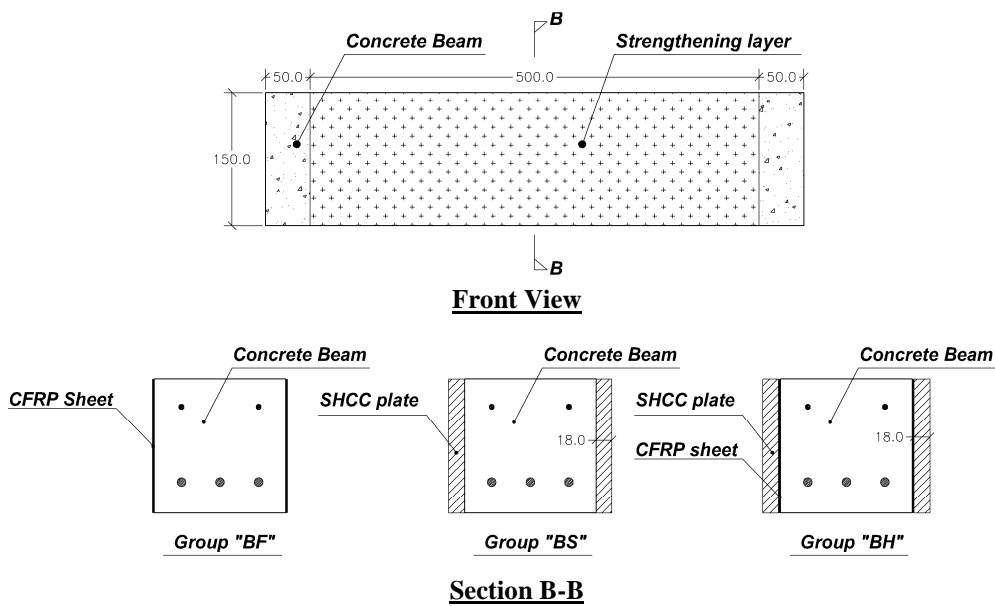

**Figure 3:** Details of the strengthening techniques applied to the beams of type "B"

## 2.2. Material properties

Ready mix was used for the casting of the concrete beams. An average compressive strength of 21.2 MPa was obtained from the compressive tests on the standard cylinders (150×300 mm<sup>2</sup>) at the age of 28 days.

The commercial name of the utilized carbon fabric was S&P C-Sheet 240. According to the supplier, this fabric has a tensile young's modulus of 240 GPa and a nominal tensile strength of 3800 MPa. The fabric elongation at rupture is 1.55%. The thickness of fabric is measured as 0.3 mm.

According to the supplier, the S&P 50 epoxy resin, at the age of 14 days, develop a tensile strength of 35.8 MPa and a modulus of elasticity around 2.6 GPa.

The SHCC was composed of a cementitious mortar reinforced with 2% of volume short discrete PVA fibers. The PVA fiber used in this study was produced by Kuraray Company and is designated RECs15x8. Both mechanical and geometrical properties of this fiber are presented in Table 2. The mortar was consisted of type I 42.5R Portland cement, fly ash, micro silica sand with maximum grain size of 0.5 mm, water and chemical admixtures. These constituents were mixed, according to the proportions included in Table 3, up to the time that a homogenous mortar was obtained. At this time the fibers were added and mixed for 5 minutes. As already mentioned, two SHCC specimens were extracted from each panel for the characterization of the tensile behavior of the developed composite. A notch was executed in each lateral side at half of the length of the specimens to localize the crack formation. The average curve for tensile stress versus crack opening width of the 8 specimens is presented in Figure 4. According to this figure the average tensile stress at crack initiation and the average tensile strength of the SHCC is 2.43 MPa and 3.35 MPa, respectively. More details on the mixture preparation and test setup of the SHCC can be found in [14, 15].

**Table 2:** Properties of PVA fiber

Fiber Type	Diameter	Length	Nominal tensile strength	Apparent tensile strength *	Modulus of elasticity	Density	Elongation
	$\mu\text{m}$	mm	MPa	MPa	GPa	$\text{gr}/\text{cm}^3$	%
RECs15x8	40	8	1600	1092	40	1.3	7

\* The tensile strength of fiber embedded in cementitious matrix.

**Table 3:** Composite mix proportions based on the weight ratio percentage

<i>Fly ash / Cement</i>	<i>Water / B*</i>	<i>Sand / B*</i>	<i>Admixtures/B*</i>	<i>PVA fibers**</i>
120	30	50	2.2	2

\* B: Binder (cement + fly ash)

\*\* Percentage of total composite mix volume.

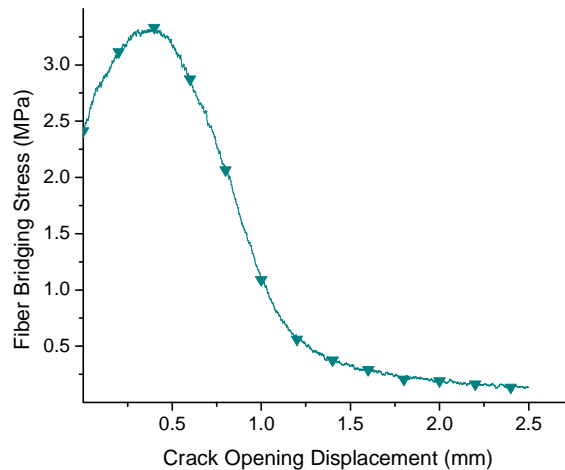
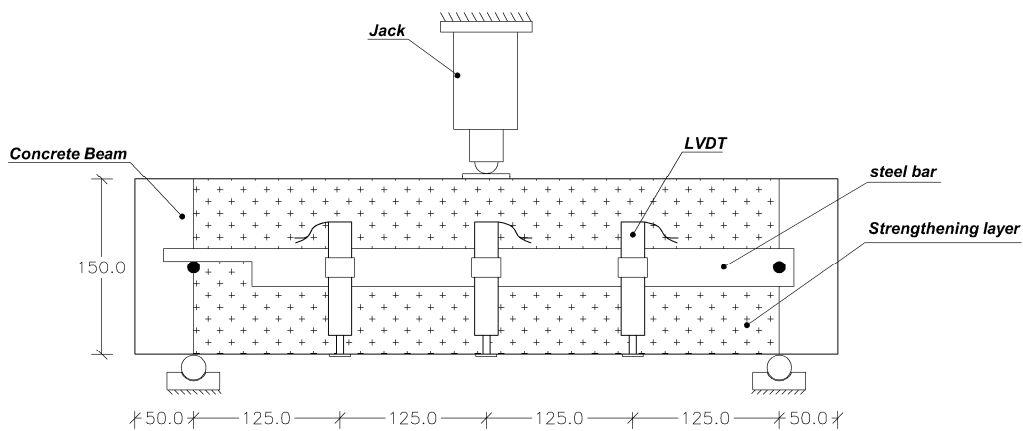

**Figure 4:** The average results of the tensile tests, single crack opening, on the SHCC specimens

### 2.3. Beam bending test setup

Figure 5 shows the setup of the three-point beam bending test. The supports were placed at 50 mm far from the extremities of the beams, conducting to a free span to sectional depth ( $l/h$ ) of 3.3. The load was applied using an actuator with a 150 kN load cell located at the mid span of the beam, therefore the shear span to effective depth ( $a/d$ ) was around 2. These conditions provide the formation of mechanism of load transference from the point load to the support. Three LVDTs were used to measure the deflection of the beam. These LVDTs were attached to a metal bar fixed at mid-height of

the beam in the alignment of its supports, in order to assure that the LVDTs only register the deflection of the beam. Another external LVDT was fixed to the body of jack and was used to control the test loading conditions by imposing a displacement rate of 5  $\mu\text{m}/\text{sec}$  to the piston of the actuator.

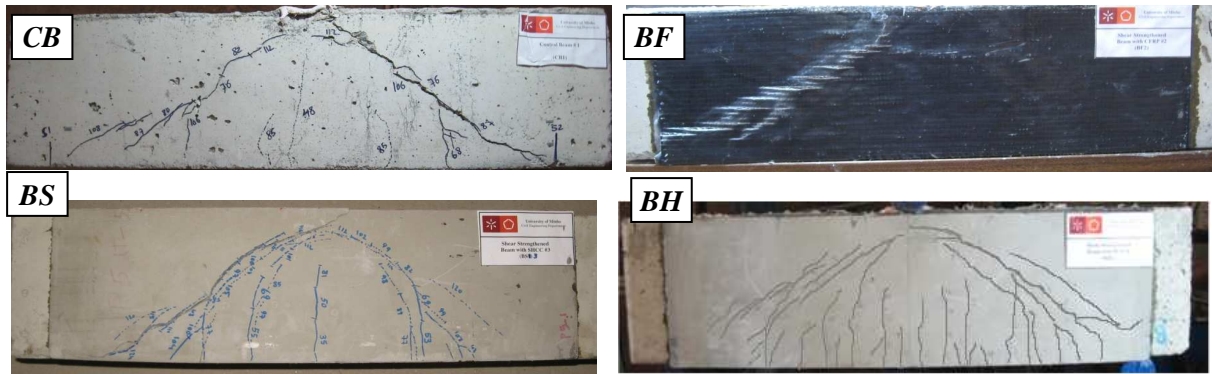

**Figure 5:** Details of the three point beam bending test setup (dimensions in mm)

### 3. RESULTS AND DISCUSSION

The crack patterns and the failure modes of the beams in each group were almost the same. However, the beams in group “BS” showed more scattered responses. This could be attributed to an eventual non-uniform bonding of SHCC plates to the underneath beam’s concrete surfaces. Although the interior surface of the SHCC plates has been grinded, some variations in the thickness of the plate were still expected. Since the SHCC plate, in spite of a carbon fabric sheet which is very flexible, has some out of plane bending stiffness, low viscose resin epoxy was not the best for the proper filling of these zones of imperfections.

The typical crack patterns for each group of the beams are showed in Figure 6. A flexural crack was initially emerged at the mid-span of the “CB” beams in tension zone. With the increase of the deflection of the beams, new cracks formed symmetrically at left and right sides of this existing crack. At higher load levels, these cracks were slightly inclining and progressed toward the top of the beam, while new flexural cracks were formed in the span between these latter cracks and supports. These cracks were formed almost in the position of the second stirrups counted from each end of the beams. Only slightly after passing the longitudinal steel bars, these cracks were inclined and oriented to the direction of a line which was connecting the loading point and each support. According to the principle of the mechanism of the load transfer in deep beams, this is the zone where a diagonal compressive strut is already formed. A change that is registered in the slope of the load-deflection response for these beams, confirms the initiation of a shear crack which is bridged by the act of the vertical steel reinforcement in this region. After this point no further flexural cracks were formed, neither the existing ones were progressed anymore. Only these inclined cracks were advanced towards the load point and the supports. When the lower part of these cracks reached to the longitudinal rebars, due to the dowel effect of this reinforcement, the load has still increased while new inclined cracks were branching from these two major cracks. Soon after this crack was localized at the left side of the beam the ultimate load was reached and started to decrease gradually. The splitting crack which was formed along the middle longitudinal rebar at the bottom of the beam, close to the left support, indicates the occurrence of de-bonding for these rebars at the ultimate stage of the loading. Due to the propagation of the inclined crack through the compressive region, the failure mode of these beams could be considered as the “diagonal tension”.



**Figure 6:** Typical cracks pattern and the failure modes of the beams

The beams in the group “BF” were failed with a brittle response due to the sudden de-bonding of the CFRP sheet. The de-bonding was initiated from lower part at the end of the CFRP. The beams were inspected after peeling off the CFRP sheet. As shown in Figure 7, two major diagonal cracks, between the loading point and the left support were formed. Intersecting of the longitudinal rebars by these cracks resulted in increasing the width of the splitting cracks and sliding of the rebars. Sliding of longitudinal rebars was followed by forming new cracks at the region where the anchorage of the rebars was provided by 90 degrees bend. No visible cracks were observed in the right portion of the beam.

The sequences of the formation and development of the cracks for the beams strengthened with SHCC plates (group “BS”) were almost the same as the “CB”. The only noticeable difference was the higher numbers of tight cracks which were branched from the main flexural and shear cracks. No visible de-bonding was occurred at the interface between the SHCC plates and the beam. Moreover the arching shape of the cracks was more significant.



**Figure 7:** Observation of inclined cracks in BF1 (CFRP was peeled off after the test)

The combination of the CFRP and SHCC plate, group “BH”, conducted to the formation of higher number of flexural cracks on the surface of the SHCC plate. These cracks were evenly distributed along the loading span as a consequence of a better bond stress transfer to the SHCC plate through the CFRP sheet. In fact, installing the SHCC plate over the flexible CFRP fabric was effective to achieve a more uniform flow of the resin epoxy. This improved the bond conditions between the CFRP and the substrate, as the HCP was delaminated with a thin layer of the underneath concrete cover attached to its interior face, Figure 8.

According to the average load versus mid-span deflection of these beams, presented in Figure 9, the maximum load carrying capacity of “BH” showed an increase of 19% as compared to the control beams (“CB”). “BS” and “BF” just attained 91% and 74% of the “CB” load capacity. The mid-span deflection of “BS” and “BH” at the peak load was almost 27% lower than the corresponding value for “CB” which was 3 mm. Significant increase in the initial bending stiffness of “BS” and “BH” was achieved. This increase was 2.3 and 2.7 times, respectively, higher than “CB” which is promising for the service loads. The increase in the elastic bending stiffness of “BF” as compared to “CB” was marginal.

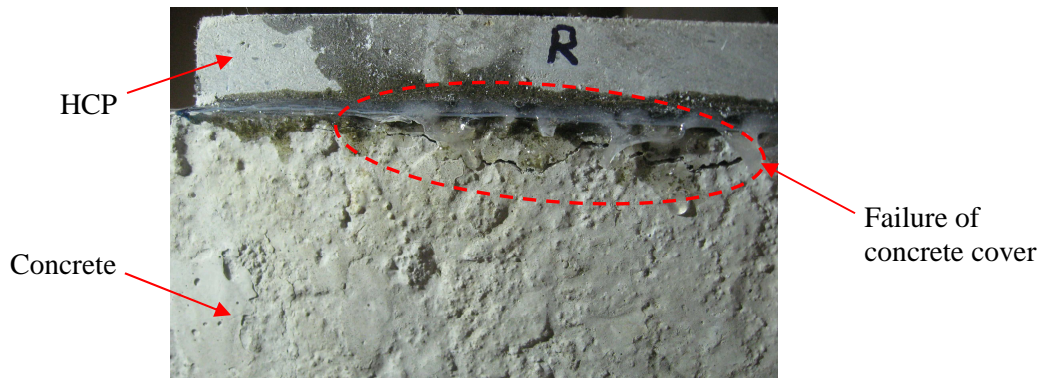

Figure 8: Failure of concrete cover caused the delimitation of HCP (Top view of BH1)

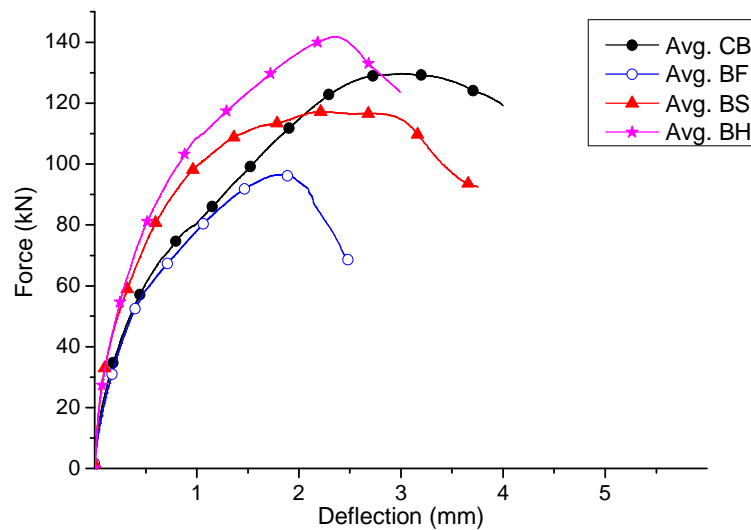

Figure 9: Average load versus mid-span deflection for different beams

#### 4. CONCLUSIONS

This paper reports the results of a preliminary experimental program for the assessment of the potentialities of using SHCC plates for the strengthening of RC elements. The effectiveness of using the CFRP, SHCC plate and HCP (combination of SHCC plate and CFRP sheet) for the shear strengthening of deep beams was evaluated. The SHCC plate was found to be effective to increase the load carrying capacity of deficiently shear reinforced deep beams when compared to both control beams and the beams strengthened with the other solutions. This improvement can be attributed to the contribution of the SHCC to the resistance of the compressive strut, and the fiber reinforcement mechanisms that offer resistance to the crack opening and to the development of high stress gradients in the CFRP at the critical cracks, which delays a premature occurrence of peeling. The ultimate load carrying capacity by using the HCP technique was higher than the control beam. Higher initial flexural stiffness was another positive aspect provided with both SHCC and HCP strengthening solutions. The benefits of using SHCC plate should be explored in terms of adding extra protection to the CFRP in terms vandalism acts, and humidity and temperature detrimental effects. It is also supposed that the SHCC plate can be efficiently installed in RC structures with mechanical fasteners, since the tensile strain character of the SHCC seems capable of supporting the tensile stress gradients due to the applications of the fasteners, leading to a better mobilization of the CFRP sheet. Also the efficiency of this technique for different orientations of the CFRP should be investigated. The economic competitiveness taking into account the initial and long term costs/savings should be also investigated under the framework of life cycle analysis of strengthened RC structures.



## **ACKNOWLEDGMENTS**

The study presented in this paper is a part of the research project titled “PrePam –Pre-fabricated thin panels by using advanced materials for structural rehabilitation” with reference number of PTDC/ECM/114511/2009. The first author acknowledges the grant SFRH/BD/65663/2009 provided by FCT. The authors also thank the collaboration of the following companies: Sika for providing the sand, Grace for the superplasticizers, Dow Chemical Co. for viscous modifying agents, SECIL for supplying the cement, ENDESA Compostilla power station for the fly ash and CiviTest for the execution of the beams.

## **5. REFERENCES**

- [1] 318 AC. Building Code Requirements for Structural Concrete (ACI 318-05) and Commentary (ACI 318r-05): American Concrete Institute; 2005.
- [2] Zhang Z, Hsu C, Moren J. Shear Strengthening of Reinforced Concrete Deep Beams Using Carbon Fiber Reinforced Polymer Laminates. *Journal of Composites for Construction*. 2004;8(5):403-14.
- [3] G HK. Experimental and numerical studies on behaviour of FRP strengthened deep beams with openings [MSc]2012.
- [4] Toutanji HA, Gomez W. Durability Characteristics of Concrete Beams Externally Bonded with FRP Composite Sheets. *Cement and Concrete Composites*. 1997;19(4):351-8.
- [5] Zhang LL, Zhang L, Ma JX. Durability of the Bonding Performance of FRP-Concrete Interface Externally Bonded with FRP Composite Sheet. In: Smith ST, editor. *Asia-Pacific Conference on FRP in Structures (APFIS 2007)* Hong Kong, China: International Institute for FRP in Construction; 2007.
- [6] Cleary DB, Cassino CD, Tortorice R, Newell JA, Tyers BW. Effect of Elevated Temperatures on a Fiber Composite Used to Strengthen Concrete Columns. *Journal of Reinforced Plastics and Composites*. 2003;22(10):881-95.
- [7] Leone M, Matthys S, Aiello MA. Effect of elevated service temperature on bond between FRP EBR systems and concrete. *Composites Part B: Engineering*. 2009;40(1):85-93.
- [8] Coelho M, Fernandes P, Sena-Cruz JM, Barros JAO. Bond behavior between concrete and multi-directional CFRP laminates using the MF-EBR strengthening technique. *Advanced Materials Research*. 2012;452-453:1110-5.
- [9] Li VC, Shuxin W, Wu C. Tensile Strain-hardening Behavior of Polyvinyl Alcohol Engineered Cementitious Composite (PVA-ECC). *ACI Materials Journal*. 2001;98(6):483-92.
- [10] Li VC, Wu C, Ogawa A, Saito T. Interface Tailoring for Strain-hardening PVA-ECC. *ACI Materials Journal*. 2002;99(5):463-72.
- [11] Redon C, Li VC, Wu C, Hoshiro H, Saito T, Ogawa A. Measuring and Modifying Interface Properties of PVA Fibers in ECC Matrix. *ASCE J Materials in Civil Engineering*. 2001;13(6):399-406.
- [12] Kojima S, Sakata N, Kanda T., Hiraishi M. Application of direct sprayed ECC for retrofitting dam structure surface-application for Mitaka-Dam. *JCI Concrete J*, 42(5). 2004;42(5).
- [13] Kim YY, Fischer G, Li VC. Performance of Bridge Deck Link Slabs Designed with Ductile Engineered Cementitious Composite. *ACI Structural Journal*. 2004;101(6):792-801.
- [14] Esmaeeli E, Manning E, Barros JAO. Strain hardening fibre reinforced cement composites for the flexural strengthening of masonry elements of ancient structures. *Construction and Building Materials*. 2013;38(0):1010-21.
- [15] Esmaeeli E, Barros J, Mastali M. Effects of curing conditions on crack bridging response of PVA reinforced cementitious matrix. 8th RILEM international symposium on fibre reinforced concrete: challenges and opportunities (BEFIB2012). Guimaraes, Portugal2012.