

A Simplified Methodology for Parameters Measurement of an Axial Flux Permanent Magnet Motor Without Neutral Point

Delfim Pedrosa, Henrique Gonçalves, Bruno Exposto, Júlio S. Martins, João L. Afonso

Centro Algoritmi – University of Minho

Guimarães, Portugal

{delfim.pedrosa|henrique.goncalves|bruno.exposto|julio.martins|joao.l.afonso}@algoritmi.uminho.pt

Abstract — The recent developments in the area of electric vehicles resulted in the growth of the interest for Axial Flux Permanent Magnet Motors, mainly because of their high power density. For the design of the motor drive it is of extreme importance to have the motor parameters, although many times the manufacturers do not provide them. To overcome this problem, in this paper is presented a methodology to obtain the parameters of this type of motor, in order to make possible the implementation of the $d-q$ model. In synchronous motors with permanent magnets the inductance changes with the rotor position, so the $d-q$ model is used to simplify the analysis and to get a better understanding of the motor parameters. Thus, this paper presents the $d-q$ model of an axial flux permanent magnet synchronous motor with two external stators and one internal rotor.

Keywords - Axial Flux Permanent Magnet Motor; AFIR-S motor; Parameters Measurement, $d-q$ Model.

I. INTRODUCTION

The electric mobility is a reality of nowadays and different solution and technology developments appear every day. The type of motor used for the powertrain is an important, if not the most important, part of it. A wide range of electric motors can be used for the electric vehicles propulsion system (Fig. 1). However not all them presents good performance to be applied to the powertrains of an electric vehicle. Four types of electric motors have shown to have the necessary characteristics for this type of application, namely: the DC motor, the induction motor, the permanent magnet synchronous motor, and the reluctance motor [1, 2].

The main characteristics of an electric vehicle's powertrain system are:

- High torque and power density;
- High torque at low velocity and high power at nominal velocity;
- Wide speed range with constant power;
- High breaking efficiency;
- High reliability and robustness;
- Low operation noise;
- Acceptable cost.

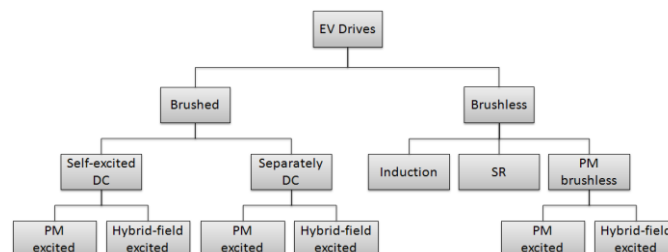

Fig. 1. Main types of electric motors used in electric vehicles [3].

Due to the strong bet in Axial Flux Permanent Magnet (AFPM) motors in electric vehicles powertrain, the interest in AFPM synchronous motors has increased in the last years. As consequence, new topologies have been developed [4].

Associated to the motor is the drive system, a power electronics converter that is responsible for adapting the voltage from the energy storage system to the motor voltage so that it can operate in accordance to the expected dynamic characteristics of the application. For the design of the drive system, namely in the simulation phase, it is of most importance to have a good definition of the motor parameters. However, many times the manufacturers do not make available all the needed parameters, and measure them in an AFPM motor is not a straightway task. In this way the main purpose of this paper is to establish a methodology to obtain these parameters.

In this paper is presented a methodology for the parameters measurement of an AFPM motor with two external stators and one internal rotor (a type of motor denominated AFIR-S motor - Axial Flux slotted Internal Rotor external Stator Permanent Magnet motor). The parameters are necessary to define a $d-q$ model of the motor. In synchronous motors with permanent magnets, in which the inductance changes with the rotor position, the $d-q$ model is used to simplify the analysis, and also because with it is easier to understand the influence of the different motor parameters over its behavior. It is intended also a methodology that is simple to implement and which use equipment that are easily available to drive system designers.

Before establishing the methodology to obtain the parameters, it is necessary to make some assumptions [5-7]:

- The windings of the stator produce a sinusoidal Back-EMF;
- The windings of each of the three-phases are equal;

- The existing harmonics in the gaps of the rotor are neglected;
- The reluctance in the air-gap is constant;
- The presence of damper windings is not considered (usually they are not used in permanent magnets motors);
- The magnetic saturation is considered, but the eddy current effect and hysteresis are neglected.

II. AFPM MOTORS

The Axial Flux Permanent Magnet (AFPM) motors can have different construction settings: *single sided*, *double sided* or *multi stage* (Fig. 2). The *single sided* axial flux motors are divided into two groups: *slotted stator* and *slotless stator (non-slotted)*. The *double sided* motors are also divided into two groups: *internal stator* and *internal rotor*. The group of *internal stator*, in turn, can be divided into three: *slotted stator*, *slotless stator* and *coreless stator*. The group of *internal rotor* is divided in two groups: *slotted stator* and *slotless stator*. On the other hand the *multi stage* motors are divided in three types: *slotted stator*, *slotless stator* and *coreless stator* [4,8]. It is possible to have different configurations with one or more internal rotors or with an external rotor. The permanent magnets can be internal or at the surface. In accordance with the number of rotors the motor can have one or more stators. There is a greater variety of choices when selecting the most suitable configuration for the desired application.

In Fig. 3 (left) is shown the motor that was used to explain the methodology proposed in this paper, and whose parameters are presented. It is an AFIR-S motor from the *PermMotor* manufacturer. It was especially designed to be used in the electrical vehicles powertrain. It has a high power density: 30 kW and 29.5 Kg of weight. Its configuration is a *double sided internal rotor*. So, it is composed by one rotor and two stators, as represented in Fig. 3 (right). The stator cores are laminated with radial orientation of the *slots*, filled in by the three-phase windings. The construction of the aluminum flange allows a better heat exchange in comparison with the other topologies.

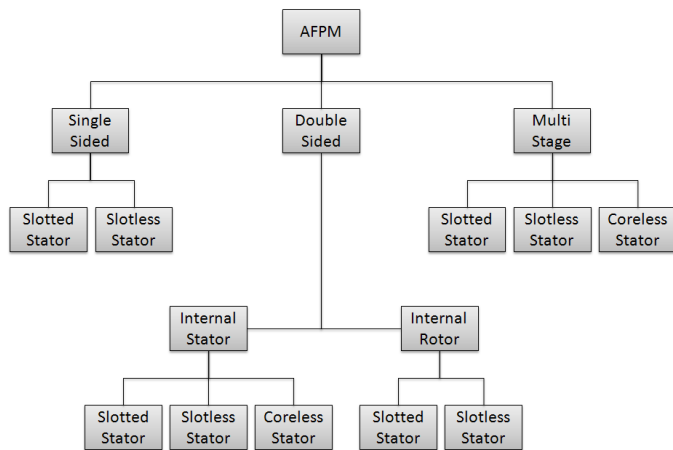

Fig. 2. Topologies of the Axial Flux Permanent Magnet (AFPM) motors.

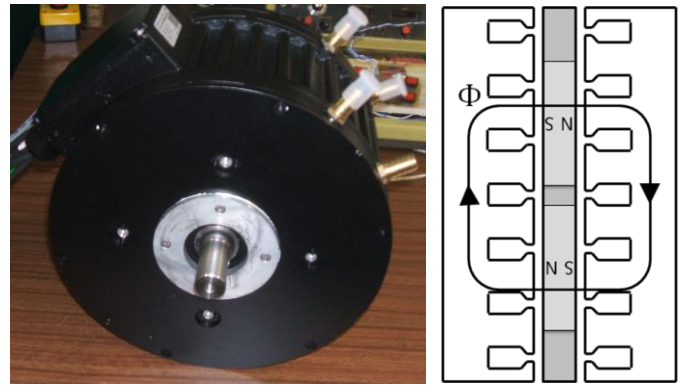

Fig. 3. AFIR-S Axial Flux Motor (on the left); Topology with flux direction (on the right) [6].

The rotor of the AFIR-S Axial Flux motor has a disc shape (Fig. 4), with the feature of being constructed in a special plastic, which allows the reduction of the weight and inertia. The use of recesses *NdFeB* permanent magnets in the rotor allows a high magnetic flux, which enables the production of a high mechanical torque in the shaft. In Fig. 5 are presented the main operating curves of the motor, given by the manufacturer. It is presented the torque vs. speed curve and the power vs. speed curve

The theoretical analysis of the electrical and dynamic behavior of the motor is usually made by means of an equivalent circuit of the motor. This model is of great importance to support the motor drive system design, since with it is possible to evaluate the instantaneous effects of varying voltages/currents, stator frequencies and torque disturbance on the machine and drive system.

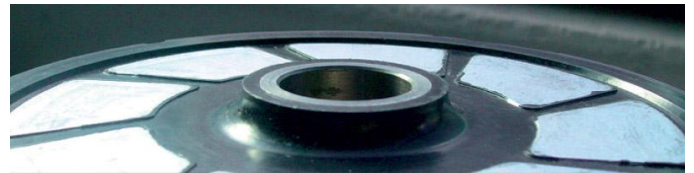

Fig. 4. Rotor of the AFIR-S Axial Flux motor used in the development of the methodology for parameters measurement [9].

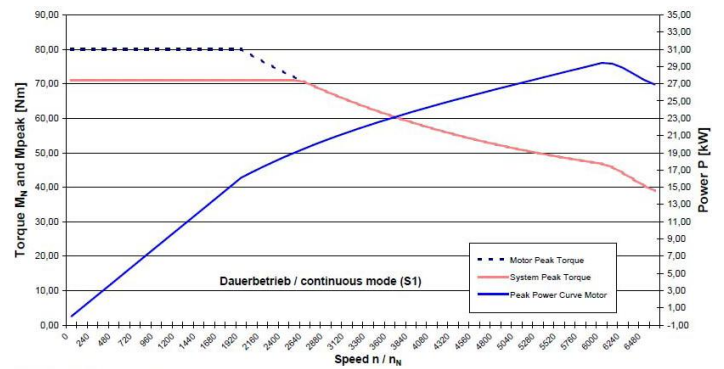

Fig. 5. Torque vs speed curve and power vs speed curve of the AFIR-S motor used in this study [9].

The dynamic model of a permanent magnet synchronous machine is derived using a two-phase motor in direct and quadrature (hereafter referred to as d - q) axes. This approach is desirable because of the conceptual simplicity obtained with only one set of two windings on the stator. The rotor has no windings, only magnets. The magnets are modeled as a current source or a flux linkage source, concentrating all its flux linkages along only one axis. The winding inductances are dependent on the rotor position. Constant inductance for windings is obtained by a transformation to the rotor by replacing the stator windings with a fictitious set of d - q windings rotating at the electrical speed of the rotor. The equivalence between the three-phase machine and its model using a set of two-phase windings is derived from a simple observation and graphical projections. The concept of power invariance is introduced whereby the power in the three-phase machine and its equivalent two-phase model must be equal. The transformation from the two-phase to the three-phase variables of voltages, currents, or flux linkages is derived in a generalized way [10]. The equivalent d - q model of the AFIR-S motor, considering the linkage Permanent Magnet (PM) flux is shown in Fig. 6 [4,8].

The AFIR-S motor in study has two stators. The windings of the two stators are connected in parallel, so that they can be fed by the same power supply. Before connecting the windings of the stators in parallel, it is necessary to identify the phase sequence of the windings of both stators.

To identify the phase sequence of both windings of the AFIR-S motor, it was coupled to an induction motor (see the test bench in Fig. 7). With this configuration the AFIR-S motor is put to work as a generator. Measuring the generated voltage waveforms the phase sequence of the windings can be correctly identified. In Fig. 8 is possible to visualize the six line-to-line voltages in the windings of the two stators. When the voltages of each phase are overlapped (as seen in Fig. 8), the phase sequence of both windings is synchronized, and the correct connection of the windings in parallel can be done.

III. MEASUREMENT METHODOLOGY

As aforementioned, to optimize the performance of the powertrain drive system, it is necessary to have access to all the

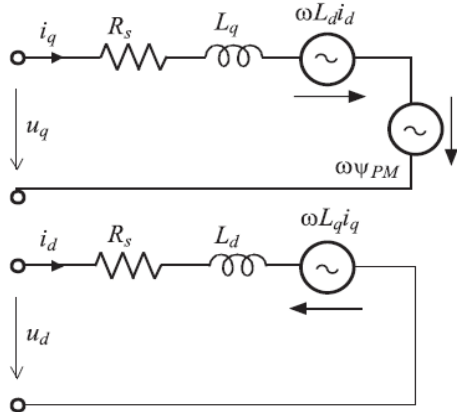

Fig. 6. Equivalent d - q model of the AFIR-S motor [11].

parameters of the motor during the design phase. The use of a simulation model as close as possible to the real motor will improve the obtained results. In this Section, it will be described and demonstrated, the methodology for the parameters measurement of an AFIR-S motor, including, stator resistance (R_s), synchronous inductances L_d and L_q , back EMF constant (k_e) and rotor PM flux linkage (λ_m).

The greatest difficulty on measuring the parameters in permanent magnet synchronous motors is the impossibility to remove the magnetic field produced by the permanent magnets. Also, some parameters cannot be directly measured since they depend on the operating conditions of the motor. As consequence, the traditional methods to obtaining the parameters of a synchronous motor cannot be used to measure the parameters of the permanent magnets synchronous motor. Below are presented with more detail the proposed methodology to obtain the needed parameters.

A. Phase Stator Resistance Measurement

When the neutral point is accessible, the measurement of the winding resistance is direct. When the windings of the



Fig. 7. Test bench assembled to synchronize the AFIR-S windings.

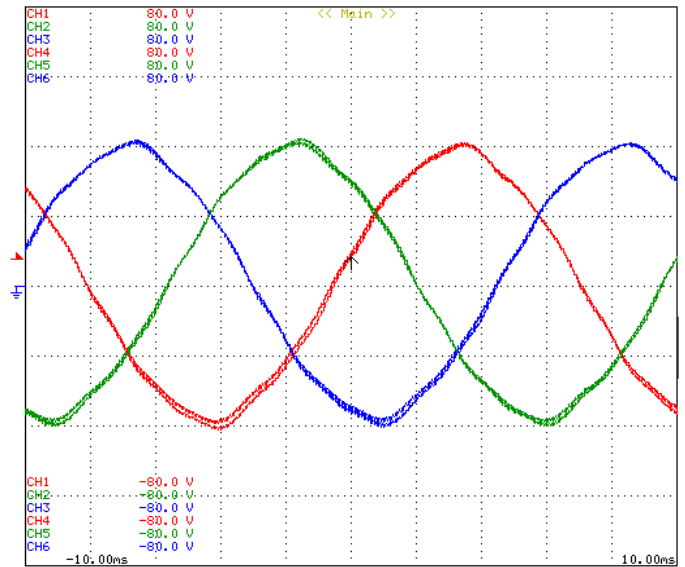

Fig. 8. Line-to-line voltages at the terminals of the two stators windings of the AFIR-S motor during the synchronization test.

stator are connected in star but the neutral point is not accessible, the value of the resistance can be obtained measuring the resistance between two phases and then dividing it by two, since the windings are symmetric. For a more accurate measurement it should be done with a high precision ohmmeter or RLC meter.

As it is of common knowledge, the value of the windings resistance changes with the temperature. So, the measured value can be adjusted applying (1) [6,7,12,13]:

$$R_f = R_i [1 + \alpha(T_f - T_i)] \quad (1)$$

Where, R_f is the final value of the resistance, R_i is the measured value of the resistance, α is the temperature coefficient of the windings material, T_f is the value of the measured temperature and T_i is the value of the ambient temperature.

To increase the measurement reliability it is important that the windings temperature is maintained constant during the measurement process.

The results presented in this paper were obtained with a precision RLC meter (*PM630A, PHILIPS*).

B. Synchronous Inductances L_d and L_q Measurement

An important consequence of the method of mounting the motor rotor magnets is the difference between direct and quadrature axes inductance values. The stator inductance when the direct axis, or magnets, are aligned with the stator winding is known as direct axis inductance. When the magnets are rotated from the aligned position by 90° , the stator flux sees the interpolar area of the rotor containing only the iron path and the inductance measured in this position is referred to as quadrature axis inductance [11]. These two inductances are important parameters for the motor model. This way it is possible to measure them using the configuration presented in Fig. 9 and using a RLC Meter. The relationship between the measured inductance and the L_q and L_d inductances are given in (2) and (3) [7]. It should be considered that this is only true if the three phase windings of the motor are symmetric.

$$L_q = \frac{2}{3} L(\theta = 0^\circ) \Leftrightarrow L_q = 191.8 \mu H \quad (2)$$

$$L_d = \frac{2}{3} L(\theta = 90^\circ) \Leftrightarrow L_d = 199.5 \mu H \quad (3)$$

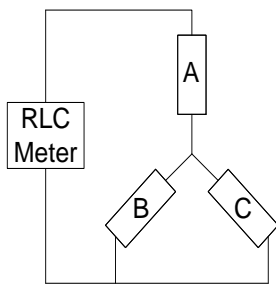

Fig. 9. Connection diagram to measure the synchronous inductance.

The L_q inductance is measured when the rotor position (θ) is in 0° , i.e., the q -axis of the rotor is aligned with the winding of the phase a , (2). To obtain the value of L_d the proceeding is the same, differing only by the position of the rotor, that in this case should be rotated by 90° , and the value is obtained from (3).

C. Peak Line-to-Line Back EMF Constant and PM Flux Linkage (λ_r) Measurement

In order to measure the peak line-to-line Back EMF it is necessary to put the motor in operation as a generator with no-load, at a constant speed of 1000 rpm, and then measure the peak amplitude of the generated line-to-line voltage. Fig. 10 shows the voltage obtained with the AFIR-S motor.

Often, the motor windings are connected in star (WYE) and the neutral point is not accessible. In these cases it is impossible to measure the simple phase peak amplitude voltage produced by the motor, and consequently it is not possible to directly determine the Back-EMF constant (k_e). Taking into account the previous conditions, the motor behaves as a balanced three-phase system, so it is possible to obtain the peak amplitude of the line voltage from the peak amplitude of the line-to-line voltage. This way it is possible to obtain the value of k_e from (4), as described in [13].

$$k_e = \frac{E_{abpk}}{\sqrt{2} \times \omega_e} \quad (4)$$

Where, E_{abpk} (V) is the peak amplitude value of the open-circuit line-to-line stator voltage generated, and ω_e (rad/s) is the value of the electric angular velocity of the motor.

Due to the impossibility to remove the field excited PM rotor in the motor for direct measurement of the rotor PM flux parameter, the rotor PM flux linkage in function of the rotor position parameter can be calculated with the following equation as presented in [13]:

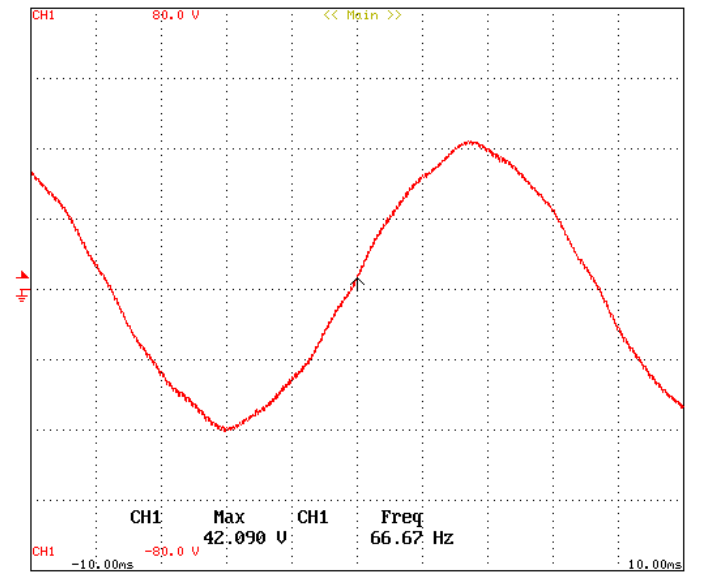

Fig. 10. Line-to-line voltage waveform when the motor operates as a generator without load at a speed of 1,000 rpm.

$$\lambda_r = \frac{2}{\sqrt{3}} \times k_e \quad (5)$$

Where, λ_r is the PM flux linkage in Wb.

D. Number of Poles

The number of poles can be obtained from (6), which relates the mechanical speed with the electric speed of the motor.

$$w_e = \frac{P}{2} \times w_m \quad (6)$$

Where, P is the number of poles and W_m (rad/s) is the value of the mechanical angular velocity of the motor.

In Fig. 11 is shown the relation between the mechanical and electrical angle of the AFIR-S motor used in this study. The position given by the position sensor cannot be directly presented because it uses a communication protocol. So it was configured a communication protocol between the position sensor and a microcontroller. The measured value is decoded by the microcontroller algorithm and then is sent to a DAC output. The resulting output is represented by the black waveform in Fig. 11. The maximum value on the right corresponds to the 360°. Knowing that the motor has 8 poles the relationship between the electrical and mechanical angle is from 4 to 1, as it can be confirmed in the same figure.

IV. PARAMETERS OF THE AFIR-S MOTOR

In Table I are presented the main characteristics of the AFIR-S motor. It includes some data given by the motor manufacturer and also the parameters obtained through the proposed methodology as described.

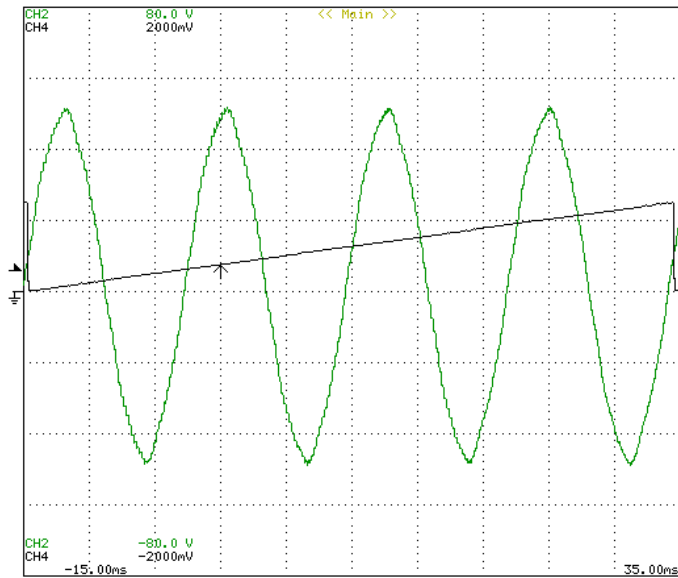

Fig. 11. Relation between the mechanical (black) and electrical (green) angle of the AFIR-S motor used in this study.

TABLE I. CHARACTERISTICS OF THE AFIR-S MOTOR

Characteristics	Value
Nominal Power P_N (kW)	30
Stator Winding Connection	WYE (without neutral point)
Nominal Voltage V_N (V)	187
Nominal Current (A)	113.5
Speed (rpm)	6,000
Voltage constant [V/1,000 rpm]	42.1
Torque (Nm)	47.7
Number of Poles p	8
Nominal Frequency (Hz)	400
Stator Resistance R (m Ω)	26.3
Inertia J (mkgm ²)	5.86
Weight m (kg)	29.6
d-axis Stator Inductance L_d (μ H)	199.5
q-axis Stator Inductance L_q (μ H)	191.8

V. CONCLUSION

In this paper was presented a methodology to obtain the main parameters of an Axial Flux Permanent Magnet (AFPM) synchronous motor without neutral point. The motor used in this work corresponds to an AFPM motor with two external stators and one internal rotor, a type of motor denominated AFIR-S motor.

Some traditional methods to obtain the parameters of synchronous motors cannot be used with permanent magnets synchronous motors, due to the impossibility to remove the flux produced by the permanent magnets.

With the methodology described in this paper, it is possible to obtain the main values of the parameters needed to accurately define a d - q model for the AFPM motor to support computer simulation and the design of drive systems.

ACKNOWLEDGMENTS

This work is financed by FEDER Funds, through the Operational Programme for Competitiveness Factors – COMPETE, and by National Funds through FCT – Foundation for Science and Technology of Portugal, under the projects PTDC/EEA-EEL/104569/2008 and MIT-PT/EDAM-SMS/0030/2008.

REFERENCES

- [1] X. D. Xue, K. W. E. Cheng, N. C. Cheung, "Selection of Electric Motor Drives for Electric Vehicles," Universities Power Engineering Conference, Australasian, 14-17 December, 2008.
- [2] Mounir Zeraouia, Mohamed El Hachemi Benbouzid, Demba Diallo, "Electric Motor Drive Selection Issues for HEV Propulsion Systems: A Comparative Study," IEEE Transactions on Vehicular Technology, vol. 55, November 2006.
- [3] K.T. Chau, C.C. Chan, C. Liu, "Overview of Permanent-Magnet Brushless Drives for Electric and Hybrid Electric Vehicles," IEEE Transactions on Industrial Electronics, vol. 55, June 2008, pp. 2246-2257.
- [4] F. Profumo, A. Tenconi, "Axial flux machines drives: a new viable solution for electric cars," IEEE Transactions on Industrial Electronics, vol. 44, 1997, pp. 39-45.

- [5] E. Belicová, V. Hrabovcová, Eason, B. Noble, and I. N. Sneddon, "Analysis of an axial flux permanent magnet machine (AFPM) based on coupling of two separated simulation models (electrical and thermal ones)," *Journal of Electrical Engineering*, vol. 58, 2007, pp 3–9.
- [6] A. Tenconi, F. Profumo, M. Lazzari, A. Cavagnino, "Axial flux interior PM synchronous motor: parameters identification and steady-state performance measurements," *IEEE Transactions on Industry Applications*, vol. 36, november/december 2000, pp. 1581-1588.
- [7] D. Y. Ohm, "Dynamic model of pm synchronous motors," 2000, Virginia.
- [8] J. Gieras, R. Wang, M. Kamper, "Axial Flux Permanent Magnet Brushless Machines", 2008.
- [9] Perm-Motor. (2010 July 12), [online]. Available: <http://www.perm-motor.de>
- [10] Ramu, K., "Permanent Magnet Synchronous and Brushless DC Motor Drives," 2009, CRC Press/Taylor & Francis.
- [11] E. Belicová, Valéria Hrabovcová, "Analysis of an axial flux permanent magnet machine (AFPM) based on coupling of two separated simulation models (electrical and thermal ones)", *Journal of Electrical Engineering*, vol. 58, 2007, pp. 3-9.
- [12] Ramu, K., "Permanent Magnet Synchronous and Brushless DC Motor Drives," 2009, CRC Press/Taylor & Francis.
- [13] R. Monajemy, "Control Strategies and Parameter Compensation for Permanent Magnet Synchronous Motor Drives," October 2000, Virginia.
- [14] S. Ozturk, "Modelling, simulation and analysis of low-cost direct torque control of pmsm using hall-effect sensors," December 2005, Texas.