

# TEMPERATURE, FLOW AND ECCENTRICITY MEASUREMENTS IN A JOURNAL BEARING WITH A SINGLE AXIAL GROOVE AT 90° TO THE LOAD LINE

L. Costa\*, A. S. Miranda\*, J. C. P. Claro\* and M. Fillon\*\*

\*Universidade do Minho, Departamento de Engenharia Mecânica, 4810 Guimarães, Portugal

\*\*Université de Poitiers, Laboratoire de Mécanique des Solides, URM CNRS 6610, BP 179, 86960 Futuroscope, France

## ABSTRACT

Parametric experiments have been conducted to analyse the influence of some supply conditions on the performance of a steadily loaded journal bearing. Temperature distribution on the internal surface, flowrate and bearing eccentricity were measured for different sets of operating conditions, at variable supply conditions. Quantitative information is provided which shows the effect of both shaft speed and applied load on maximum bush temperature and flowrate. It has been observed that flowrate was modestly affected by load and significantly affected by rotational speed, oil supply temperature and supply pressure. Maximum bush temperature was modestly affected by supply pressure, moderately affected by load and significantly affected by shaft speed. For low applied loads, the attitude angle was markedly affected by supply pressure. The experimental results also showed that for a small groove length there is a variation of bush temperature in axial direction in the groove region.

## 1- INTRODUCTION

Hydrodynamic journal bearings are currently designed to operate at high specific loads and high rotational speeds with good performance. Under these operating conditions, a significant amount of heat is generated by viscous shearing in the oil raising its temperature. Furthermore, the supplying conditions (supply pressure, supply temperature, groove dimensions and location) dictate flowrate, therefore affecting oil temperature inside the bearing. As a result, oil viscosity and bearing load capacity will be affected. Thermal effects in hydrodynamic lubrication play, therefore, a crucial role on the prediction of the bearing characteristics. On the other hand, it is important to bearing designers to be able to predict to what extent how much the bearing performance can be affected by oil supply conditions.

In hydrodynamic journal bearings working on a steady state regime, oil is usually supplied to the bearing through axial grooves. Very often in practical applications, the bush can not be installed with the lubricant supply groove on the load line. Alternatively, the bush can be mounted with the groove at 90° to the load line.

Experimental investigations on the thermohydrodynamic performance of journal bearings have been carried out over many decades [1,2], but there is little experimental information concerning the influence of the supply conditions on the thermal behaviour of journal bearings with one axial groove at 90° to the load line [3]. Recent experimental investigations have been carried out using bushes with one groove on the load line [4,5], and two diametrically opposed axial grooves [6,7]. According to published results the supply conditions affect the bearing performance (maximum temperature, flowrate, power loss and friction torque) in different ways, being evident the need to consider all supply parameters to make a more precise analysis of the bearing performance. Many authors [8,9] have encouraged experimental work in the field of thermal analysis in bearings, in order to enable the improvement of theoretical models.

This work aims to contribute to a more clear view of the effect of lubricant supply conditions on bearing performance and to add results to the stock of thermohydrodynamic data currently available for journal bearings. Three journal bearings with one single axial groove located at 90° to the load line have been tested under steady load, laminar flow, for a range of variation of supply conditions, with different combinations of speed and load.

## **2- BEARINGS GEOMETRY AND OIL SPECIFICATIONS**

The characteristics at 23 °C of test bearings and lubricating oil used in this experimental work are given in Table 1. A photograph of one of the instrumented bushes, mounted in its cylindrical housing, is shown in Fig. 1(a). Bushes and housings were made of RG5G-CuSn5ZnPb bronze. A 35 mm thick bronze cylinder (bush) was pressed into a 15 mm thick bronze cylinder (housing). Bush inner diameter was measured using a high precision analogic comparator with a resolution of  $10^{-6}$  m. The rotating shaft (stainless steel X22-CrNi17) was ground to an ISO N4 finishing quality. A high precision coordinate measuring machine with a resolution of  $10^{-7}$  m, was used to measure shaft diameter. The values of bush inner diameter and shaft diameter were taken as the average of six measurements. The lubricant used was the mineral oil Galp Hydrolep 32 (ISO VG 32 type). Oil viscosity was obtained using a falling ball viscometer following the procedures specified by DIN 53097.

## **3- TEST RIG AND EXPERIMENTAL MEASUREMENTS**

A test rig that has been initially designed and manufactured to investigate the influence of supply conditions on oil flowrate, was modified for the present work. Full details of the test rig can be found elsewhere [10]. Only a brief description is given here.

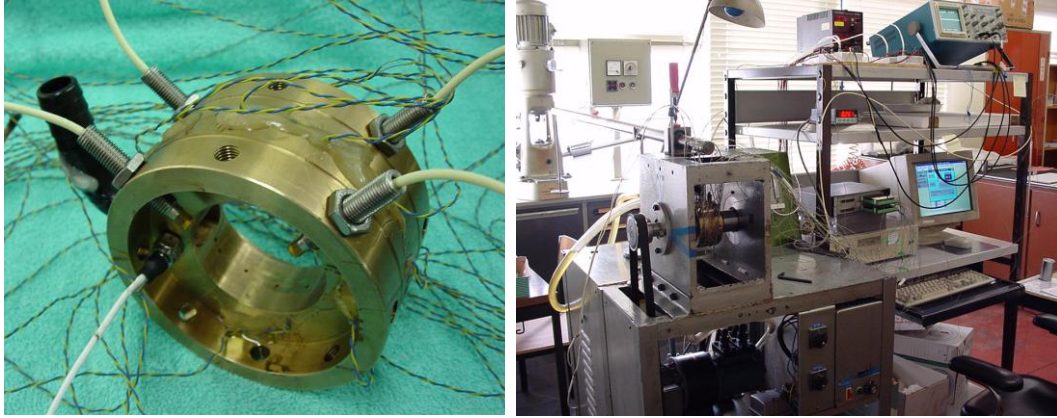

(a)

(b)

Figure 1- Photograph showing the instrumented test bush (a) and a general view of the experimental apparatus (b)

Table 1: Essential bearing dimensions and oil viscosity characteristics

			Bearing A	Bearing B	Bearing C
Bearing nominal diameter	d	$10^{-3}$ m	50	50	50
Bearing length	b	$10^{-3}$ m	40	40	25
Bush outer diameter	D	$10^{-3}$ m	100	100	100
Radial clearance at 23°C	$C_r$	$10^{-6}$ m	38.5	40.75	45.76
Length of supply groove	a	$10^{-3}$ m	20	32	20
Width of supply groove	w	$10^{-3}$ m	10	10	10
Groove location	$\phi$	degrees	90	90	90
Oil viscosity at 30 °C	$\mu_{30}$	Pa.s	0.0467	0.0467	0.0467
Oil viscosity at 75 °C	$\mu_{75}$	Pa.s	0.0083	0.0083	0.0083

A general view of the experimental apparatus is illustrated in Fig. 1(b). Basically consists of a test bearing, a rotating shaft, a lubricant feeding system, a loading system, a temperature measurement system, and a digital oscilloscope connected to the displacement transducers used to measure film thickness.

The rotating shaft is rigidly mounted on two high precision conical roller bearings that are pre-loaded in order to remove any radial clearance and to ensure good stiffness. The shaft is driven through a timing belt by a continuously variable speed electric motor (0.95 kW). The rotational speed was measured with a reflection type tachometer, which ensured a speed control to an accuracy of  $\pm 2$  rpm.

The loading system (Fig.2) consists of dead weights applied to a loading arm, acting through needle bearings on a closed loop steel wire attached to the bush. The bearing

applied load corresponding to a given set of dead weights was measured using a high precision load cell with an error less than  $\pm 0.5$  N.

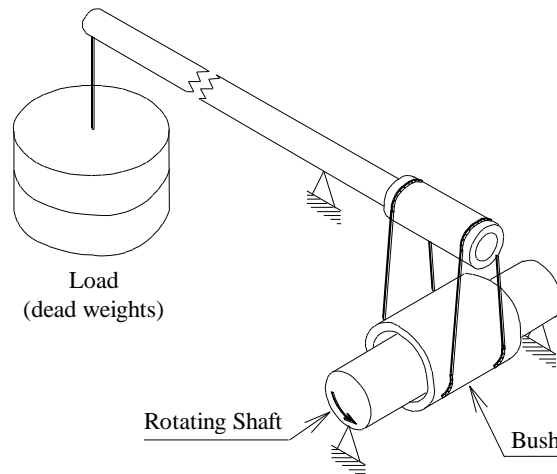

Figure 2-The test bearing loading system

A hydraulic pump ( $3.6 \times 10^4$  litres/min.,  $16 \times 10^2$  kPa) was used to supply oil to the bearing. The flowrate was measured by a precision gear flowmeter, which was calibrated for the range of operating oil viscosity, with an accuracy of  $\pm 3\%$ . By using a manual pressure limiting valve and a pressure dumper, the oil could be supplied to the bearing at any pressure less than 400 kPa. A pressure transducer located at the internal surface of the supply groove was used to measure the oil supply pressure with an accuracy of  $\pm 0.8$  kPa over the operating supply pressure range.

For temperature measurements type J thermocouples were mounted flushed with the internal surface of the bush. Twenty one thermocouples have been used in bearings A and B, while in bearing C thirteen thermocouples were used. The circumferential and the axial locations of the thermocouples are shown in Fig. 3. In order to measure oil supply temperature two thermocouples were used in the flexible feeding tube at the bearing entry. Additional thermocouples were mounted in order to bring out the oil groove temperature, the environment temperature, oil draining temperature and oil tank temperature. The signals provided by thermocouples were monitored using a data acquisition card inside the computer. Each thermocouple has been calibrated by comparing its reading of water temperature in a thermostatic vessel with that of a high precision analogic thermometer. The discrepancies observed were within the range  $\pm 1.25$  °C, this being, therefore, assumed as the accuracy of the thermocouples.

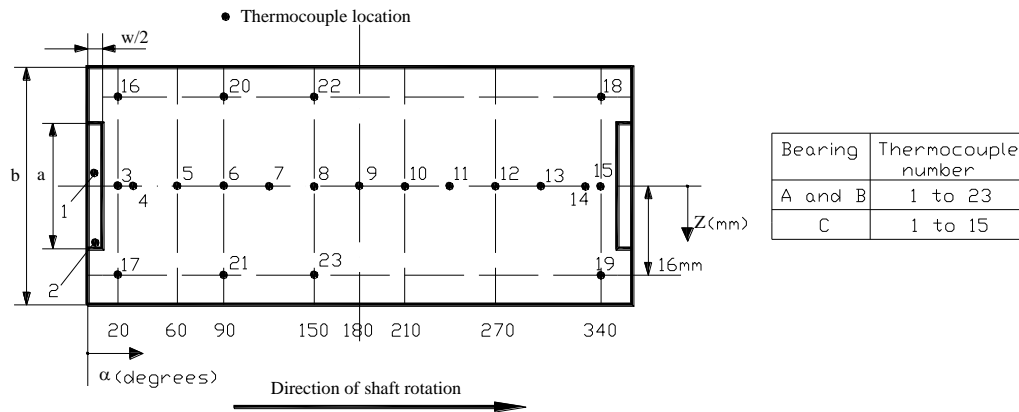

Figure 3- Location of thermocouples for temperature measurements

Bearing eccentricity ratio and attitude angle were calculated from measurements of film thickness using four displacement transducers situated in transverse planes set in the front and back of the bearing. Signals from these transducers were transferred to a digital oscilloscope, the indicated displacement being used to determine the bush position in relation to the shaft centre. For this purpose, it was necessary to estimate shaft and bush thermal expansion, considering a temperature variation from an initial temperature (23°C) to the average value of the bush inner surface temperature.

Test conditions are listed in Table 2. Experimental results for each set of operating conditions were recorded after thermal equilibrium had been attained. During testing, shaft speed was maintained within  $\pm 2$  rpm of the specified value, whereas oil supply temperature and oil supply pressure were maintained within  $\pm 1$  °C and  $\pm 1$  kPa of the specified values, respectively. Each test was performed at least three times in different days and at different times of the day. Repeatability of results was checked. The largest differences observed were  $\pm 1.5$  °C for maximum bearing temperature,  $\pm 4.4$  % for flowrate and  $\pm 6.5$  % for eccentricity ratio.

Table 2- Essential test conditions

Parameter			Specifications
Speed	N	rpm	2000, 3000 and 4000
Load	W	kN	0.5, 1, 2, 3, and 4
Oil supply pressure	$P_s$	kPa	100 and 300
Oil supply temperature	$T_s$	°C	35 and 45
Ambient temperature	$T_a$	°C	20 to 32

### 3- RESULTS AND DISCUSSION

Typical circumferential temperature profiles at the inner surface of the bush are plotted in Fig.4. The specific load was 2 MPa for bearings A and B, and 2.4 MPa for bearing C. The maximum bush temperature occurred in a region between 115 and 130 degrees away from the inlet section, as expected in a convergent film region where the rate of shear in the oil is strongly marked. Bush temperature in bearing A is considerably higher than in bearing B (Fig. 4(a)). This is because the radial clearance of bearing A is smaller than that of bearing B, this being a reason for higher oil shear rate and, consequently, higher heat generation on bearing A. Furthermore, bearing A having a smaller groove length than bearing B, suffers a reduction in the cooling effect of the flow of oil supply which is lower than in bearing B. In Fig. 4(b) is shown the circumferential temperature profiles at the inner surface of bearing C, at two different oil supply temperatures. As might be expected, the higher oil supply temperature resulted in higher bush temperatures. However, the difference on maximum temperature (8.6 °C) is lower than that at the bearing entry (10 °C).

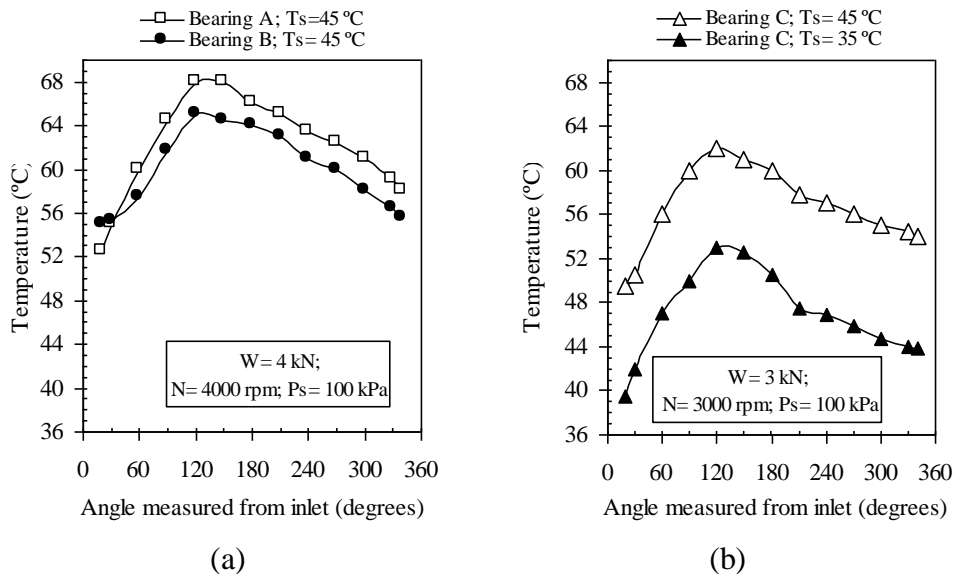

Figure 4- Circumferential temperature profiles at the inner surface of the bush on bearing mid-plane for different operations conditions

The axial temperature in the inner surface of the bush has been carefully examined for all tests carried out with bearings A and B. Fig. 5 shows the axial variation of bush temperature in these bearings at similar operating conditions. The axial temperature gradient was only significant in the vicinity of the groove inlet section of bearing A. In this case, the groove length is significantly lower than the bush length ( $a/b= 0.5$ ), consequently a significant part of the recirculating flow of hot oil does not mix directly

in the groove with the supplied fresh oil. This mixing of oil (oil reformation) takes place downstream of the groove accounting for the observed temperature variation.

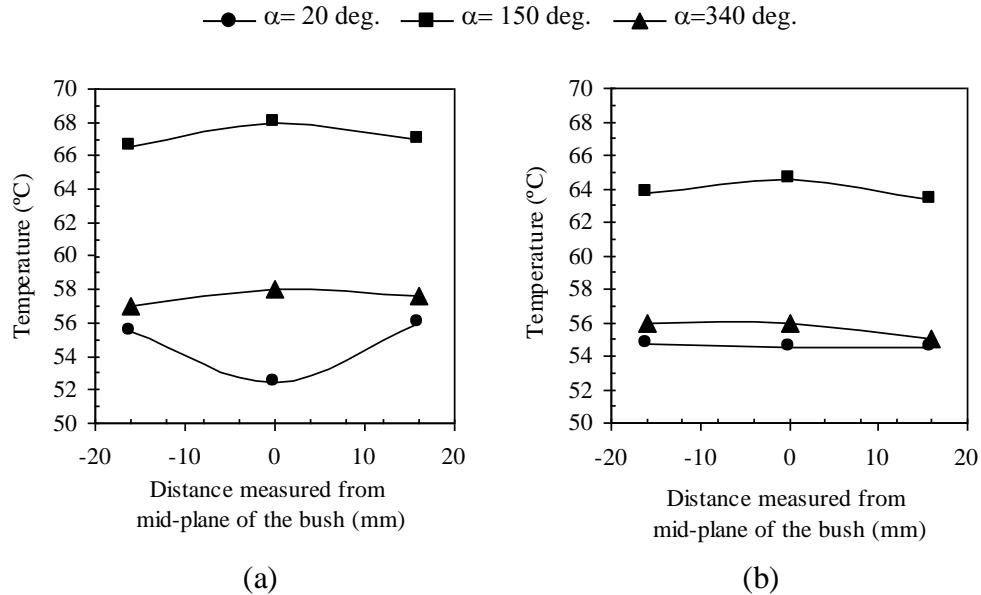

Figure 5- Axial temperature profiles at the inner surface of the bush for bearings A (a) and B (b), with  $W = 4$  kN,  $P_s = 100$  kPa and  $N = 4000$  rpm

The effect of shaft speed on bearing performance characteristics has been investigated using bearing A. The experimental results of maximum bush temperature, oil flowrate and bearing eccentricity ratio are shown in Fig. 6. It can be observed that maximum bush temperature and flowrate increased slightly with increasing load. Maximum bearing temperature increased significantly with increasing shaft speed, due to increasing shear rate in the oil. An increase in shaft speed from 2000 rpm to 4000 rpm caused an increase in flowrate of about 48 %. Measured eccentricity ratio increased significantly as load increased. For a shaft speed of 4000 rpm the measured eccentricity ratio was lower than for 2000 rpm. This happens as result of the prevalence of the hydrodynamic effect over the decrease in oil viscosity induced by higher viscous dissipation.

Performance characteristics of bearing B, were measured for two different supply pressures. The results are depicted in Fig. 7. It can be observed that there is a significant effect of load on maximum bush temperature. The cooling effect of flowrate, which increases as load increases, was probably frustrated by the increase in heat generated by viscous dissipation due to an extended full film region. Oil supply pressure had a non significant effect on maximum bush temperature. The attitude angle increased with increasing oil supply pressure. This effect was more significant for low applied loads. This may be explained by the existence of a hydrostatic effect of supply pressure over

the inlet region, which generates a pressure force component that pushes the shaft increasing the attitude angle.

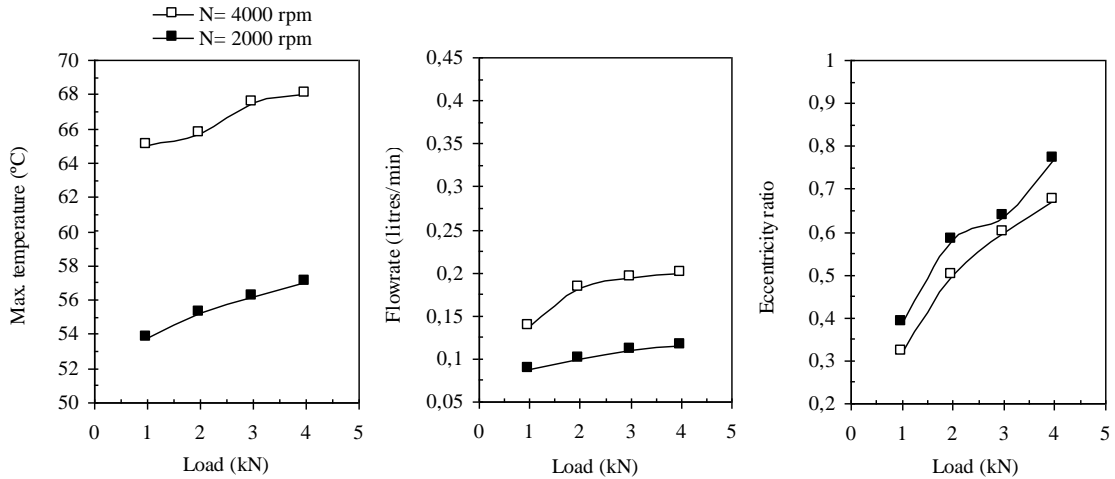

Figure 6- Measured performance characteristics of bearing A for variable shaft speeds, at fixed  $T_s = 45\text{ °C}$  and  $P_s = 100\text{ kPa}$

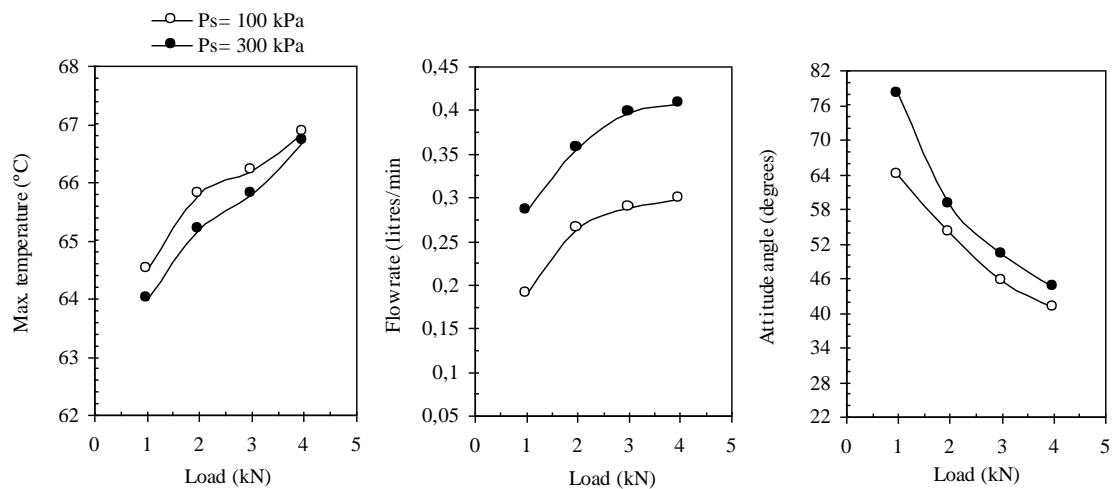

Figure 7- Measured performance characteristics of bearing B for variable oil supply pressure, at fixed  $T_s = 45\text{ °C}$  and  $N = 4000\text{ rpm}$

A change in oil supply temperature produces changes in the film viscosity field and, as a result, in the film thickness distribution. Fig. 8 shows the measured performance characteristics of bearing C, at two different supply temperatures. The decrease of oil supply temperature from  $45\text{ °C}$  to  $35\text{ °C}$  originated, in average, decreases of  $8\text{ °C}$  on maximum bush temperature and of 19% on flowrate. Decreasing oil supply temperature will originate an increase in oil viscosity, resulting in lower flowrates as observed.



Indeed, for fixed applied load and shaft speed, minimum film thickness increases due to an increase in oil viscosity.

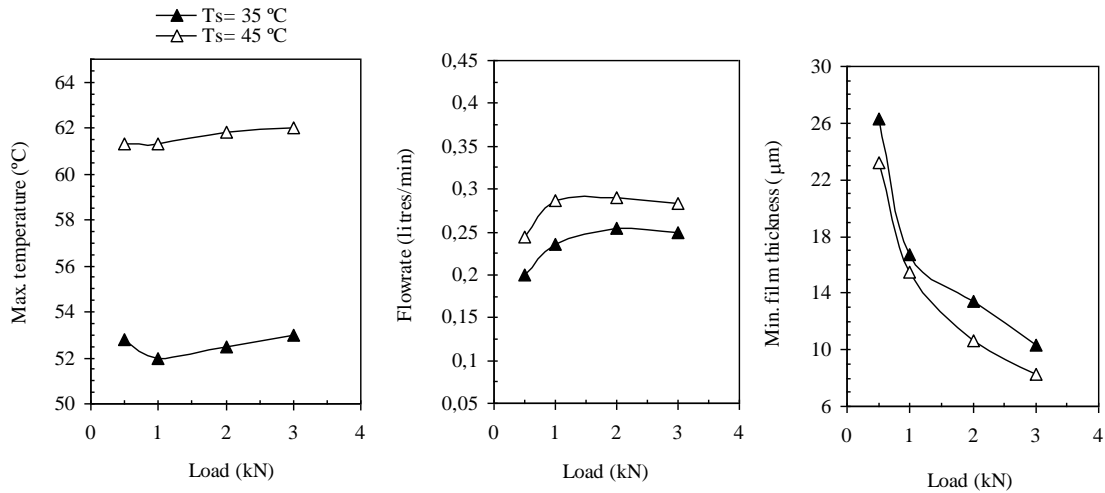

Figure 8- Measured performance characteristics of bearing C for variable oil supply temperature, at fixed  $P_s = 100$  kPa and  $N = 3000$  rpm

#### 4- CONCLUSIONS

Laboratory tests have been carried out to investigate the influence of oil supply conditions on bush temperature, oil flowrate, attitude angle and bearing eccentricity. According to the results obtained the following conclusions can be drawn:

- i) Oil supply temperature had a marked effect on bearing performance. Flowrate and maximum bush temperature increased as oil supply temperature increased. The opposite occurred for minimum film thickness.
- ii) Oil supply pressure had a strong influence on oil flowrate, but a small effect on maximum bush temperature. The influence of oil supply pressure on attitude angle was only significant for low loads.
- iii) Groove length showed a considerable influence on the axial variation of bush temperature in the downstream vicinity of the groove, especially at low supply pressures.

#### Acknowledgements

The first author is financially supported by the “*Fundação para a Ciência e Tecnologia*” (Portugal), through PRAXIS XXI Programme/BD/13922/97. This

institution is gratefully acknowledged. The authors would like to thank *Petrogal, S. A.* (Portugal) for the free supply of the lubricating oil used in the experiments.

## REFERENCES

- [1] Fillon M., Frene J. and Boncompain R., 1987, "Historical Aspect and Present Development on Thermal Effects in Hydrodynamic Bearings", Proceedings of the 13rd Leeds-Lyon Symposium on Tribology- 1986, Edited by Dowson D. et al., Elsevier Tribology Series N° 11, pp. 27-47.
- [2] Swanson, E. E. and Kirk, R. G., 1997, "Survey of Experimental Data for Fixed Geometry Hydrodynamic Journal Bearings", ASME Journal of Tribology, Vol. 119, pp. 704-710.
- [3] Hakanson, B., 1965, "The Journal Bearing Considering Variable Viscosity", Trans. of Chalmers University of Technology- Gothenburg, Sweden, N° 298.
- [4] Costa, L., Fillon M., Miranda A. S. and Claro J. C. P., 2000, "An Experimental Investigation of the Effect of Groove Location and Supply Pressure in the THD Performance of a Steadily Loaded Journal Bearings", ASME Journal of Tribology, Vol. 122, pp. 227-232.
- [5] Syverud, T., and Tanaka, M., 1997, "Experimental Investigation of the Effect of Shaft Heating and Cooling on Single Bore Journal Bearing", Wear, Vol. 207, pp. 112-117.
- [6] Ma, M. T., and Taylor, C. M., 1995, "Effects of Oil Temperature on the Performance of an Elliptical Bearing", Proc. of the 21st Leeds-Lyon Symposium on Tribology, 1994, Elsevier, Tribology Series N° 30, pp. 143-151.
- [7] Gethin D. T., and El-Deihi M. K. I., 1990, "Thermal Behaviour of a Twin Axial Groove Bearing Under Varying Loading Direction", Proc. I. Mech. E., Part C, Vol. 204, p.77-90.
- [8] Tanaka M., 1997, "Recent Analyses and Designs of Thick-Film Bearings", New Directions in Tribology, First World Tribology Congress- Mech. Eng. Pub. Ltd., London, pp. 411-433.
- [9] Pinkus, O., 1990, "Thermal Aspects of Fluid Film Tribology", ASME Press, New York.
- [10] Claro, J. C. P., 1994, "Reformulação do Método de Cálculo de Chumaceiras Radiais Hidrodinâmicas- Análise do Desempenho Considerando as Condições de Alimentação ", PhD Thesis, University of Minho, Portugal (*in portuguese*).