

Throughput limits of two 802.15.4 wireless networks applications for signal acquisition

Joel Alves¹, André Catarino², Helder Carvalho², João Monteiro¹, Ana Maria Rocha²
University of Minho, ¹Dep. Industrial Electronics, ²Dep. Textile Engineering, Portugal

joelalves.um@gmail.com; whiteman@det.uminho.pt; helder@det.uminho.pt; monteiro@dei.uminho.pt; amrocha@det.uminho.pt

Abstract- This work describes the development and test of a wireless sensor network used by a biomedical signal monitoring system. Data communication is based on a body area network (BAN) materialized as a wireless network in two versions, one based on the 802.15.4 specification and another on a higher-level Zigbee protocol. The system was developed using the Jennic JN5148 microcontroller, Jennic's ZBPro stack and the JenOs RT kernel.

The final system was tested with the devices at different distances, and with a varying number of sensor nodes communicating simultaneously. For each of these combinations the signal quality and frequency of communication errors were recorded.

The version implemented using Zigbee protocol was able to acquire and send sensor signals at a sample rate of 7 kSamples/s (12-bit samples, final net rate of 84 kbps) with a percentage of lost frames below 4%. It was also shown that the system supports simultaneous communication of three sensor nodes at 3 kS/s (36 kbps) each, with a percentage of losses of less than 4%. These results are important since they support the possibility of having several sensors acquiring fast biomedical signals and sending them to a central unit in real time.

I. INTRODUCTION

The work presented is part of a project – BIOSWIM - in which a swimsuit integrating sensors to measure several biomechanical, biophysical and performance parameters during exercise is under development. The parameters that will be monitored include the measurement of ECG (electrocardiographic activity), EMG (Electromyography, i.e. muscular activity), respiratory activity, accelerations and trajectories of the limbs, water pressure variations on the hands, internal temperature, among other parameters. Some of the measurements are done with textile electrodes and sensors, embedded in the fabric that constitute the swimsuit by means of an available technology in the textile industry [1][2][3]. The swimsuit should be autonomous and transmit the information to the outside of the swimming pool using wireless technology. With that objective in mind, the research team selected Zigbee as a viable approach to achieve the wireless communication due to its inherent advantages, in particular its range, cost and power consumption. The collected signals should be transmitted to a microcontroller with wireless transmission capabilities, which in turn would communicate and transmit the data to a coordinator connected through USB to a computer where an application would gather, organise and display the data. From the currently available

solutions of microcontrollers with wireless capability the team selected Jennic 5148 model.

Since the transmission is made in water, it may occur the interruption of communication, resulting in loss of and information. Other important problem is the achievable data rate transmission. EMG demands 1kHz sampling, because the bandwidth of this signal may approach 500 Hz as the highest frequency. In order to prevent data loss, the parameters are stored in non-volatile memory for later upload to the PC, in which further study and analysis are performed by a biomechanics research team by means of the previously mentioned application. Nevertheless it is crucial for the result team to have a real-time monitoring from all sensors.

The main objective of this particular work was to analyse the possibility of transmitting the data or part of it through the network in real-time, in order to understand if it can fulfil the requirements of this project, namely for the most demanding sensors. Final net sample rates of data transmitted in the final version of the system are measured and presented.

II. BACKGROUND

The Zigbee specification has been created for low-cost, low-power, low data rate, secure wireless personal area networks and provides application and security services in layers above the physical and MAC layers which are normally based on the IEEE 802.15.4 standard.

In recent work, it has been applied frequently for wireless sensor networks, especially for sensors requiring low data rates. Zigbee modules support sleep modes with very quick wake-up times and rely on low-power radios, thus allowing long battery life. The Zigbee stack implemented on the Zigbee modules automatically takes care of network formation, packet routing and maintenance. Its data rate is typically of 250 kbps and its minimal range is in the order of 100 meters in open space. Some manufacturers claim ranges in the order of 1 to 4 km using high-power modules and specific antennas. Considering these specifications, Zigbee has become an interesting alternative to Bluetooth, that presents lower range and higher power consumption, although being capable of higher data rates. Zigbee also has the advantage of being capable of forming mesh networks and connecting a higher number of nodes, which constitute an advantage to the project under development, since there are a considerable number of signals to be acquired and sent to a central unit.

Although specified as 250 kbps, the net data rate achieved by a Zigbee network seems to be considerably far from this value. The microcontroller manufacturer Jennic calculates data throughput for an 802.15.4 network as 127 kbps [4]. Moreover, the added overhead of the Zigbee layers should somewhat lower this data rate. Ashton [5] calculates an expected application throughput of about 100 kbps, but in practical tests only a 46 kbps peak data rate is reached. Burchfield *et al.* carefully implemented several optimisations on the hardware and software of commercial equipment and achieved a maximum data rate of about 110 kbps [6].

Several authors have presented wireless health monitoring systems based on Zigbee, but the data throughput requirements and performance have been rarely analysed from the final application point of view, probably because the data throughput obtained for those systems was sufficient.

Ken *et al.* [7] describe a network for monitoring ECG signals on several patients. A potential need for data compression is acknowledged in order to reduce the required data rate and thus increase the number of patients that can be monitored; however no actual data is available.

Vergari *et al.* [8] propose a home care monitoring system in which several medical parameters are measured and transmitted via Zigbee to a home concentrator. Data rate is not an issue in this case, since only one patient is being monitored, and the only parameter with a relatively high sampling rate is ECG which is sampled at 500 Hz. Another personal healthcare monitor is presented by Elneel *et al.* [9]. The choice of Zigbee is justified by the flexibility of the network and low power consumption; again data rate is not a concern, since only one ECG signal is being transmitted.

In [10] another solution for a home care medical monitoring system is proposed. The system is designed for ECG signal transmission but the proposed version only sends processed pulse and SPO2 values, needing a very low data rate. As stated before, this particular project demands for high transition rates, as it can be observed in table 1, which justifies the need of measuring the maximum data rate achievable with the adopted module. Moreover, the number of sensors involved may also influence the final performance in real time monitoring.

TABLE I
MEASURED PARAMETERS, NUMBER OF SENSORS AND TYPICAL SAMPLE FREQUENCIES REQUIRED

Parameter	N. of sensors	Required sample frequency (each sensor)
Limb acceleration (3 axes)	3x3	200 to 400 Hz
Palm pressure	1	150 to 300 Hz
Backhand pressure	1	150 to 300 Hz
ECG	1	300 to 600 Hz
Respiratory Rate	1	10 to 40 Hz
Tympanic Temperature	1	0.1 Hz
Electromiography	6	500 Hz to 1 kHz

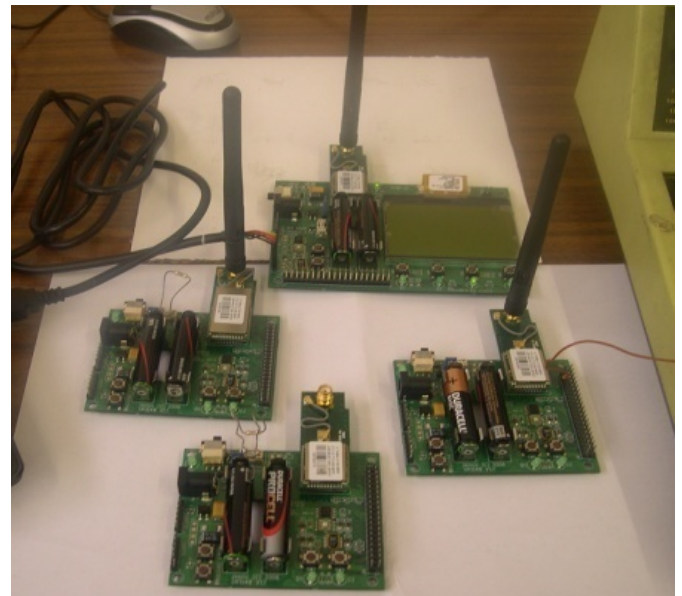

Fig. 1. Jennic development modules, coordinator (upper) and three sensor nodes(lower left, middle, right).

III. PROJECT DEFINITION AND REQUIREMENTS

The current work aims at developing a swimsuit for high-performance sports training evaluation. The swimsuit should be autonomous in terms of energy for the sensing devices and electronics, as well as able to communicate without wires to a central unit, providing data on a real time basis. This would represent an important contribution for the athletes' comfort, since no wires or cables would be connected to the outside. Since water is one of the most difficult environments to deal with when it concerns to sensors, power and communication this project can ultimately result in creating a framework for the development of similar wearable applications for health care and leisure sports.

An ideal set of variables to be measured was defined by a research team of sports experts. Table 1 shows the variables that are being implemented in the first prototype.

The processing and communication system is based on Jennic 5148 Zigbee microcontroller modules, Jennic's real-time OS (JenOs) and Jennic's ZigbeePro stack API.

Each sensor node includes one microcontroller that is able to acquire and send up to 4 analog signals with a 12-bit resolution or acquire data from SPI or I²C enabled signal conditioning chips (Fig.1). Of the first two types of nodes developed one includes 4 channels for ECG or EMG measurement and the other includes one channel for piezoelectric conditioning (for respiratory rate) and three channels for resistive sensor conditioning (tympanic temperature and palm pressure).

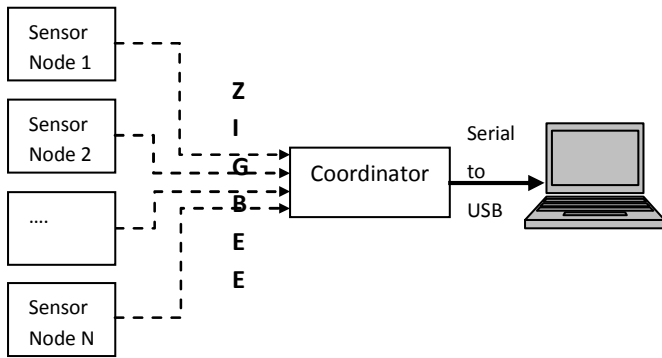

Fig. 2. Structure of the Wireless Sensor Network.

The sensor nodes form a modular star-network around one or more coordinators that connect to a PC through a serial connection, as shown in Fig.2. Each node logs the sampled data to a non-volatile RAM for later upload to the PC (through a serial link or Zigbee) and can be configured to send the sampled data in real-time.

The connection to the PC uses the maximum baudrate of 1 Mbit/s. A Labview application (Fig.3) receives, processes and displays the data from the sensor network, besides performing network management tasks.

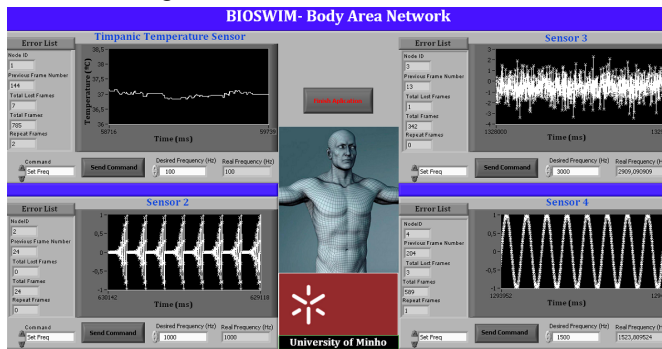

Fig. 3. Labview Application showing acquisition of test signals for 4 sensor channels

Observing the data presented in Table 1 and performing some simple calculations it is quite straightforward to conclude that the expected data rate of around 100 kbps is not enough to allow simultaneous transmission of all variables. Moreover, the system's internal management adds some additional overhead to the data transmitted.

A first version of the system was built on the ZigbeePro stack API provided by Jennic. In the configuration used, a payload of 82 bytes was defined. Fig.4 shows the composition of the payload used by the system in this version.

NodeID (2 bytes)	Frame Number (2 bytes)	Data (78 bytes packing 52 12-bit samples)
---------------------	---------------------------	--

Fig. 4. Frame structure used in Zigbee version of the Jennic's system.

The frame's header includes a sensor node identification code for system's internal use and a frame number for packet

loss management and packet ordering tasks. The actual data is sent in 78 bytes. The 12-bit samples are packed in the 78 bytes allowing 52 samples to be sent in each frame.

A simpler second version of the system would be developed based on the 802.15.4 API provided by Jennic. The objective was to avoid the data and processing overhead introduced by Zigbee. In this case, the payload was defined as shown in Fig.5:

NodeID (1 byte)	Frame Number (1 byte)	Data (96 bytes packing 64 samples 12-bit samples)
--------------------	--------------------------	--

Fig. 5. Frame structure used in 802.15.4 version of the system

The signal sampling process is quite simple and is based on a timer provided by the JenOS operating system, programmed with the desired sample frequency. The timer activates a task that performs an AD conversion using the micro's ADC(s). The sample is stored in a buffer, and when the buffer holds the number of samples required for a frame, the frame is assembled as previously shown and sent through the Zigbee network.

Zigbee has been configured with two endpoints, one used for data transmission, and another to control the sensor nodes (start and stop acquisition, set sample frequency, etc.). The configuration implemented uses frame acknowledging.

The link between coordinator and the PC is established through a Serial-to-USB converter and uses the maximum bitrate of 1Mbit/S provided by the microcontroller's UART. Synchronization is achieved using a flag byte as first byte for each frame sent through the serial link. *Bitstuffing* is used to guarantee that the flag byte never appears in the payload. This represents an additional small overhead, but given the link's data rate, no problems were expected due to it's inclusion.

IV. EXPERIMENTAL SET-UP

The two versions of the wireless sensor network were tested in the following conditions:

TABLE 2
EXPERIMENT PLANNING VARIABLES FOR TESTING THE TWO APPROACHES

Protocol	Zigbee Pro and 802.15.4
Number of nodes	1, 2 and 3
Distance / obstacles	10 cm, 10 m, 10 m + brick wall
Type of module	Normal with external antenna and High-Power
Sample frequency (Samples/s)	10, 100, 1k, 2k, 3k, 4k, 5k, 6k, 7k, 8k, 10k

Signals were transmitted in the conditions listed in Table 2. The "frame number" included in the developed software (See figures 2 and 3) allowed counting the total of frames lost during transmission. A minimum of 1000 frames were sent. The criteria used for evaluating the percentage of lost frames was, after sending and receiving the frames when the percentage loss variation stabilised within 0.1% of the

accumulated average or when 10 000 frames were completed, the test would stop. During these tests, a complementary measurement was performed to determine the Link Quality Indicator (LQI) using an application provided by Jennic.

V. RESULTS

A. Link Quality Indicator

In terms of LQI, Fig. 6 and Fig. 7 show the very significant difference between the two types of modules.

It is possible to observe from both figures that the existence

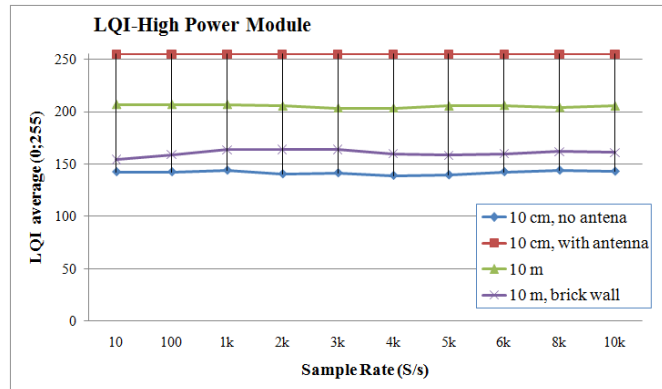

Fig. 6. Link quality indicator throughout the experiment, high power module

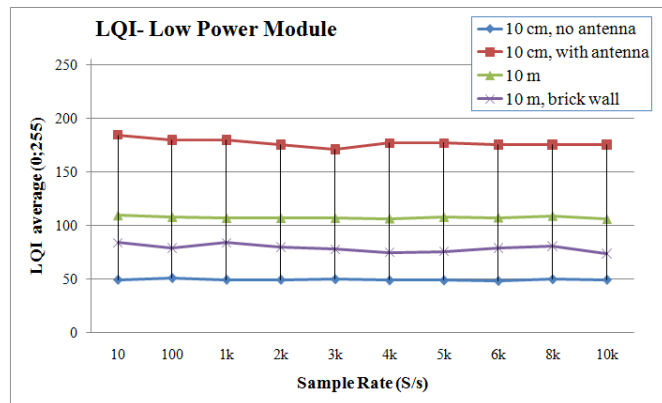

Fig. 7. Link quality indicator throughout the experiment, low power module

of an antenna is crucial. For distances above 10 cm the modules presented several problems to communicate when not equipped with an antenna. Nevertheless, the high power module presents an almost three times higher LQI than the low power module, with a dramatic reduction when the distance between node and coordinator increases. In fact, the high power module always presents higher values than the low power when comparing similar experiments.

At a distance of 10 m the LQI is almost the double for the high power module. And the same occurs when there is a distance of 10 m and a wall between the node and coordinator.

Comparing the two modules one can say that the high power module improves the signal quality for almost two times, being thus advisable to use instead of the low power

module, since distance is one important requirement for this project,

B. Lost frames – Zigbee versus 802.15.4 using low-power module

The most interesting result in this series of experiments is probably the comparison between the Zigbee and the 802-15-4-based networks (Fig. 8 and Fig.9).

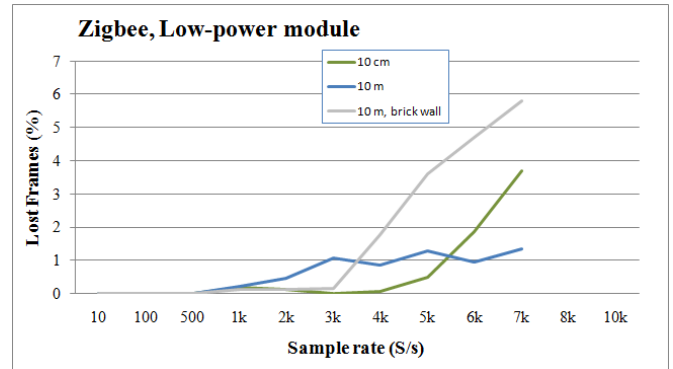

Fig. 8. Lost frames, low power module using Zigbee

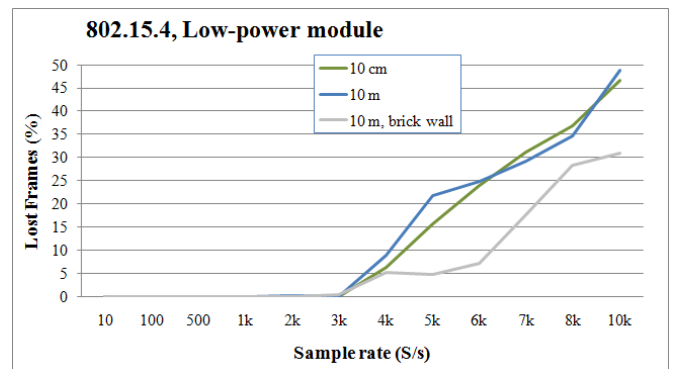

Fig. 9. Lost frames, low power module using 802.15.4

Both of the implementations start losing frames at about 3 kS/s (corresponding to about 36 kbit/s), but the more complex flow control of Zigbee allows it to present much lower frame loss than the simpler 802.15.4 version. However, the Zigbee version consistently collapsed when trying to sample above 7 kS/s. This may be due to network problems, but it is also possible that the microcontroller is not able to handle the computation load at this sample rate.

The comparison between the result found for transmission with and without a wall between the coordinator and sensor node yields an unexpected result for 802.15.4, with lower loss for the transmission through the brick wall. This may be related to external reasons, such as momentaneous interference by Wi-Fi networks on the test site, which was not monitored during the experiment, given that the objective was to have a general comparison and performance evaluation.

On basis of the results presented it is possible to determine a maximum sample rate of 3 to 6kS/s for one node, depending

on the acceptable data loss, In the case of working in a swimming pool environment this would represent 1% loss using Zigbee

C. *Lost frames – Low-power module versus high-power module using 802.15.4*

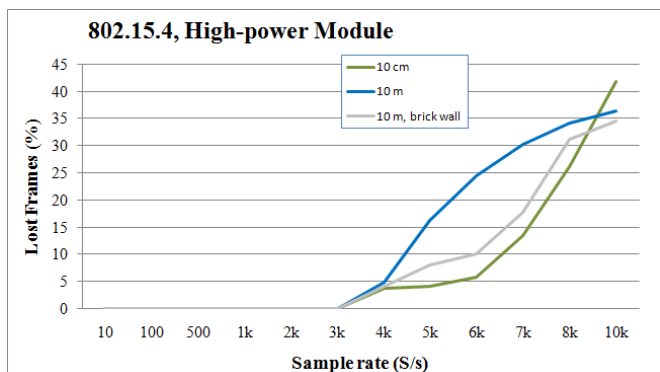

Fig. 10. Lost frames, high-power module using 802.15.4

Using the high-power module some improvement in frame loss can be observed (Fig.10), but it is not significant when considering the difference in LQI. The improvement when using the high-power module is probably more significant at greater distances and/or when more obstacles are present. Nevertheless, for both low-power and high-power, there seems to be a threshold around 4 kS/s for which the loss is around 5% and the starts to increase rapidly. If this number was acceptable, then one could transmit in real time signal in which a bandwidth could involve 1000 Hz, such as EMG signals.

D. *Lost frames – Zigbee versus 802.15.4 with multiple nodes*

In this experiment 1 to 3 sensor nodes were placed together and sampling/transmitting data at increasing sample rate. Fig.11 and Fig.12 summarize the results obtained for this particular experiment. As it can be seen on both Figures, the

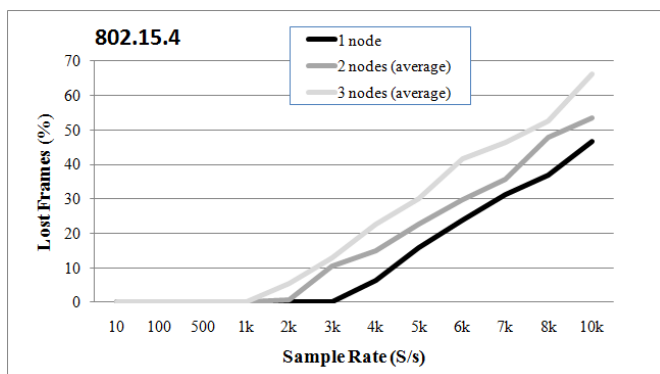

Fig. 11. Lost frames, low-power module using 802.15.4, variable number of nodes

sample rate decreases as the number of nodes present in the network has increased. Figure 11 shows a significantly higher loss in frames for 802.15.4 when compared with zigbee which is depicted in figure 12. From this experiment one could use three nodes transmitting signals acquired at a sample rate of about 3 kS/s with a loss of about 2%. However it should be noted that 802.15.4 seems to perform better for sampling rates up to 1 kS/s

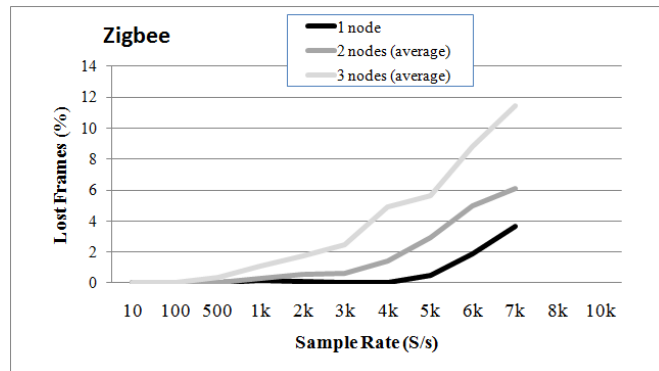

Fig. 12. Lost frames, low-power module using Zigbee, variable number of nodes

CONCLUSIONS

This paper presents a system that is being developed and intended to be used to acquire biometric and biophysical signals from a swimmer by means of an instrumented swimsuit and sent to a central unit using wireless communication, in this case Zigbee. The former was selected due to its particular advantages, in particular power consumption and range. Due to the requirements that this project demands, a study was conducted in order to understand if this wireless protocol would be able to comply. Starting with a specific microcontroller from Jennic, two different implementations were used, one based on Zigbee Pro and other based on a lower level 802.15.4 specification. Several tests were performed, involving one or more nodes simultaneously communicating with the coordinator, with different sampling rates for the acquired signals and for different distances. The results obtained showed that Zigbee Pro showed a better performance than 802.15.4, with a percentage of lost frames around 1% for sampling rates between 3 to 6 kS/s when one node is used and a distance of 10 m and about 2% at a 3 kS/s when three nodes communicate at the same time with the coordinator. The study also shows that Zigbee can be used with no difficulty on relatively slow signals. Some of the results that were not expected may be related with the fact that Zigbee works in the same bandwidth of Wi-Fi applications which might contribute for a more congested environment and thus to results below the initial expectations. Also, based on these results it is possible to use higher sample rates if the distance between node and coordinator is small.

It is interesting to note that the results of this project can in general be easily transposed to other sports and applications, such as health monitoring in leisure sports, for the elderly, patients with cardiac disease, among others.

ACKNOWLEDGMENT

The authors wish to thank FCT, which is funding this research through BIOSWIM, project, number PTDC/EEA-ELC/70803/2006.

REFERENCES

- [1] Montagna, G., Catarino, A., Carvalho, H., Rocha, A.. "Study and optimization of swimming performance in swimsuit designed with Seamless Technology", *Autex 2009 World Textile Conference*, Izmir, Turkey, 2009, May 26-28th.
- [2] Silva, M., Catarino, A., Carvalho, H., Rocha, A., Monteiro, J., Montagna, G., "Study of vital sign monitoring with textile sensor in swimming pool environment". *Proceedings of the IECON 2009, The 35th Annual Conference of The IEEE Industrial Electronics Society*, 3-5 November 2009, Porto, Portugal
- [3] Silva, M., Catarino, A., Carvalho, H., Rocha, A., Monteiro, J., Montagna, G, Textile sensors for ECG and respiratory frequency on swimsuits", *Proceedings of the Conference on Intelligent Textiles and Mass Customisation*, Casablanca, Morocco, 12-14th November 2009
- [4] Jennic Ltd. (2006-08-15), "Calculating 802.15.4 Data Rates", Application Note: JN-AN-1035. [Online, pdf]. Available: http://www.jennic.com/support/application_notes/jn-an-1035_calculating_data_rates_in_an_ieee_802154-based_network
- [5] S. Ashton, Ember Corporation. "Zigbee network performance, typical results and implications for application design". Presented at ZigBee Developers' Conference 2006 [Online]. Available
- [6] Burchfield, T. R., Venkatesan, S., Weiner, D. "Maximizing Throughput in ZigBee Wireless Networks through Analysis, Simulations and Implementations," *Proceedings of the International Workshop on Localized Algorithms and Protocols for Wireless Sensor Networks*, Santa Fe, New Mexico, June 18-20, 2007. LOCALGOS 2007. CTI Press, Athens, pp 15-29.
- [7] Ken, C; Xiaoying, L., "A Zigbee Based Mesh Network for ECG Monitoring System," *Bioinformatics and Biomedical Engineering (iCBBE)*, 2010 4th International Conference on , vol., no., pp.1-4, 18-20 June 2010.
- [8] Vergari F, Auteri V, Corsi C, Lamberti C. A ZigBee-based ECG transmission for a low cost solution in home care services delivery. *Mediterranean Journal of Pacing and Electrophysiology* 2008; 3-4:181-186
- [9] N.A. Elneel, F. Wagner, D. Schroeder, W. H. Krautschneider, "A Compact Wireless Sensor Node for Biomedical Signal Acquisition Realized as a System-in-Package", *Proceedings of SOMSED 2009*, Hamburg, Germany, 8.-9. Oct. 2009
- [10] Q. Zhao, K. Wu, J. Wu, and X. Wu, "Design of Physiological Parameter Acquisition and Communication Module Based on CC2430", *Proceedings of the 7th Asian-Pacific Conference on Medical and Biological Engineering APCMBE 2008*, 22 – 25 April 2008, Beijing, China