

150 Years of Innovation and Research in Textile Science

# BIOSIGNAL MONITORING IMPLEMENTED IN A SWIMSUIT FOR ATHLETE PERFORMANCE EVALUATION

Catarino A.<sup>1</sup>, Carvalho H.<sup>1</sup>, Rocha A. M.<sup>1</sup>, Montagna G.<sup>2</sup>, Dias M. J.<sup>3</sup>

<sup>1</sup>Department of Textile Engineering, University of Minho, Portugal,

<sup>2</sup>Faculty of Architecture, Technical University of Lisbon, Department of Art and Design, Portugal,

<sup>3</sup>Center of Textile Sciences and Technology, University of Minho, Portugal  
whiteman@det.uminho.pt

## ABSTRACT

Monitor athletes during exercise has always been a major challenge for engineers and researchers due to the restrictions involving the measurement of physiological and performance parameters. An athlete should have complete freedom to perform his normal activity, in order to be correctly monitored. The advent of e-textiles can give an important contribution to overcome these limitations since it is possible to integrate sensors in garments and thus perform monitoring without limiting the freedom of movements. This paper presents part of the work that is being carried out in the project entitled BIOSWIM, which envisions the development of an instrumented swimsuit, capable of acquiring several physiological and performance related signals with the purpose of aiding the trainer in improving the technical component of the swimmer and improve his performance. This paper will give an overview of the monitoring system and the textile sensors that were developed, namely for biopotential measurement.

## KEYWORDS

Biosignals, textile electrodes, smart suits, body networks

## INTRODUCTION

Electronic wearable solutions are presently a major area under research and development. Several solutions have been proposed in the past few years, targeted to different fields of application, especially multimedia and health applications [1,2,3,4], where subjects of critical ages need to be monitored – babies, ill or elderly persons [5]. Another important field of application is sports, both leisure as well as

performance sports [3,6,8], in which monitoring is essential for health, safety and performance improvement [7,8]. It is apparent that an electronic device embedded in a piece of garment is more comfortable than using gadgets appended to the body, and eventually added whenever a new parameter needs to be measured [9]. Another advantage is ease of use, since an entire piece of garment containing all the essential equipment for accomplishing the monitoring task may have a minimal interference with the athlete's movements [10]. However, the majority of present solutions and prototypes make use of techniques for attaching electronic devices instead of actually embedding the electronics into the fabric.

This project explores a higher level of integration of sensors in textile materials by embedding sensors and micro electronics in textile materials using their intrinsic electrical properties, which can be used for data transmission, device power supply among other possibilities, without forgetting the other main purpose of the textile material – build a textile fabric for an individual with maximum comfort and fitting.

## PROJECT OBJECTIVES AND SPECIFICATION

The main objective of this research project is the development of an autonomous instrumented swimsuit, capable of recording several signals available in real time for observation and also for later analysis. This main objective implies that the swimsuit must be waterproof, with no kind of cabling directly linked to the central computer, and with power supplies enough to power all the electronics involved for a period of two hours, which is the average time for a training session.

Other objectives involved the capability of having trigger alarms for the case of an athlete in serious risk due, for instance, to heart malfunction.

The instrumented swimsuit was conceived to measure the following parameters, organized in three classes: performance, biomechanical and physiological. For performance the research team identified the need to monitor the swimming time, the distance that was actually covered during the exercise, and the average swimming speed. The biomechanical parameters involved the number of cycles, gestural frequency, instantaneous displacement speed, hand palm pressures and angular position of pulse, elbow and neck. The physiological parameters involved EMG (Electromyography) in several muscles (Flexor digitorum superficialis, Biceps brachii, Triceps brachii, Deltoideus, Trapezius, Rectus femoris, Biceps femoris, Gastrocnemius), ECG (Electrocardiography), respiratory frequency, and tympanic temperature, among other measurements that are still under development. The focus of this paper will be on the textile electrodes used for measuring some of these parameters, namely ECG and EMG. Figure 1 illustrates sensor's positioning in the swimsuit.

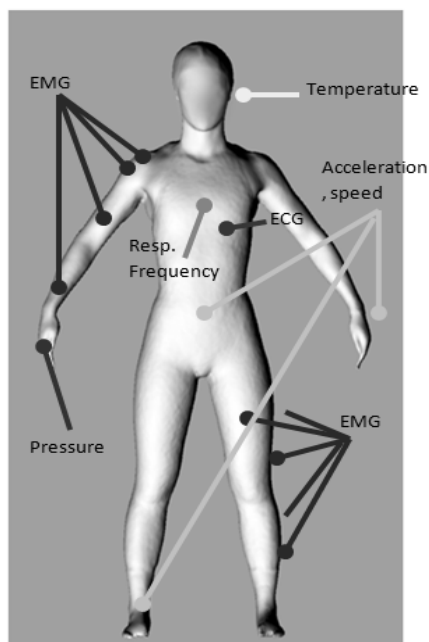

FIGURE 1. Identification and positioning of the different sensors considered in the BIOSWIM swimsuit.

## SIGNAL REQUIREMENTS AND COMMUNICATION

In order to be fully autonomous and cable-free, the BIOSWIM swimsuit must be able to communicate with a computer through wireless communication. For this purpose Zigbee wireless technology was selected, since it is capable of communicating over a distance that covers the size of an olympic swimming pool, it does not consume too much power, and the bandwidth is considered to be enough to transmit all the data involved during the experiment. The team selected the Jennic 5148 wireless microcontroller to accomplish the signal acquisition and communication tasks. This microcontroller is equipped with four channels for signal acquisition and integrated Zigbee radio, besides other functions. Jennic provides a Zigbee communication stack integrated into a real time operating system.

The BIOSWIM communication system is organized in a star structure, where a coordinator controls and receives the information sent by each one of the nodes that belong to the network. Each node is constituted by a Jennic 5148 microcontroller, which acquires up to four analog signals with 12-bit resolution, besides being able to acquire data from SPI or I<sup>2</sup>C-enabled devices. The coordinator - also a Jennic 5148 - is connected through USB to a laptop computer, where an application developed with National Instruments LabVIEW collects all data, stores, displays and analyses the results. The application was also developed to fully manage the wireless communication system. Figure 2 illustrates the structure of the wireless sensor network.

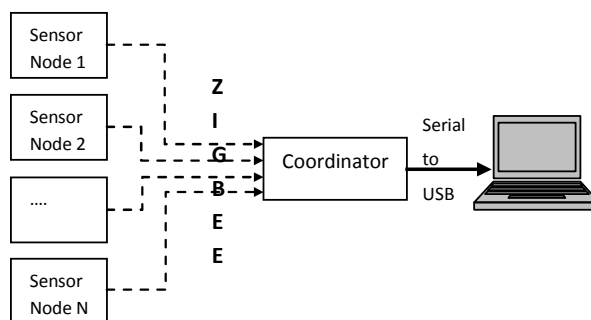

FIGURE 2. Structure of the BIOSWIM Wireless Sensor Network.

The acquisition rates are of major concern in this application, since a significant quantity of data has to be transmitted in the monitoring process. From the set of signals that this system has to collect, EMG is the one that is more demanding in terms of data acquisition rate, which is 1000 Hz. The remaining signals use lower data rates for sampling, as can be observed in Table 1. The wireless communication system was developed in order to comply with this requirement and each node is capable of sending the four signals that it is capable to acquire at this rate, which means that each node can receive and transmit signals from four EMG sensors.

TABLE I. Measured parameters and typical sample frequencies required.

Parameter	Required sample frequency (each sensor)
Limb acceleration (3 axes)	200 to 400 Hz
Palm pressure	150 to 300 Hz
Backhand pressure	150 to 300 Hz
ECG	300 to 600 Hz
Respiratory Rate	10 to 40 Hz
Tympanic Temperature	0.1 Hz
Electromiography	500 Hz to 1 kHz

Simulations on the communication of the wireless network confirmed that bandwidth and distance are sufficient to accomplish transmission of four channels at 1 kHz sample rate each, with virtually no loss of data. If all of the EMG signals are to be monitored simultaneously, this bandwidth is not enough. For this reason, the system logs data into non-volatile flash memory, which can later be wirelessly uploaded to the PC through the network. However, wireless communication is quite difficult to achieve under water, namely for this high frequency (2.4 GHz). From experiments made the team found that submerging the antennas more than 10 cm, communication is lost. For this reason,

antennas are always kept out of water, thus assuring communication. However, there are critical phases where the communication might be interrupted, such as when the swimmer jumps into the water and when the swimmer turns. Given that all data is stored in flash memories, the lost data frames can be resent to the main application and the signal can be completely reconstructed afterwards.

### SWIMSUIT PRODUCTION CONSIDERATIONS AND TEXTILE ELECTRODES FOR ELECTRIC BIOPOTENTIALS

The swimsuit was developed using MERZ, model MBS seamless knitting machine. The machine is a full jacquard circular weft knitting machine, with eight feeding heads and corresponding cams, one needle system in the cylinder, one transfer system in the dial and a vacuum-based take off system. Each feeding head contains seven yarn guides. The full jacquard capabilities are useful for building embedded electrodes in the position and the shape required for integrating communication lines.

Based on the yarn characteristics and the swimmer's biotype, it is possible to produce a customized fabric tube, with different compression effects and drawings. The compression effect was obtained combining the knitted structure, loop length and raw material properties. The mechanical characterization of these fabrics performed in previous work [9] allowed the identification and prediction of the required compression for each part of the knitted tube. The major limitation of this knitting machine is that it is not possible to produce an entire swimming suit in one single tube, if it is intended to have arms, which is the case on this swimsuit. In this situation, the fabric has to be produced in two stages, one for torso and legs, and the other for the two sleeves. After knitting, the tube is cut in predefined positions that mark areas produced with different structures, and is then bonded or sewed. The same applies to the sleeves: in this case the tube with the sleeves contains two sleeves that are cut and then bonded. After completing the sleeves, they are connected to the torso also by bonding or sewing. The tubes are thus shaped combining the structure, the loop length

and the raw material in order to result in proper compression and sensor positioning in each part of the body.

The electrodes are embedded in the fabric using special structures which were developed during the project. Since the machine only have one needle system, an approach was adopted, which is based on interchanging the base yarn with the textile conductive yarn. This allows increasing the quantity of the conductive yarn in that area.

Several structures were tested and the selected was the one that gave a better signal to noise ratio in ECG measurement. The ECG is based on three electrodes representing one vector and the position of the sensors that can be observed in figure 3 is related with the vigorous arm movement promoted when swimming.

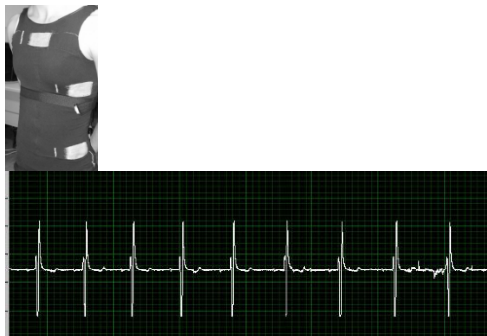

FIGURE 3. Prototype of the torso with the textile electrodes used for measuring the ECG. On the leftside the swimmer dressing the prototype and at the center and rightside the resulting ECG waveform.

Research previously conducted [7,8] showed that the artifacts produced during intense movement can be eliminated resulting in a fairly accurate QRS waveform, as can be seen in figure 4.

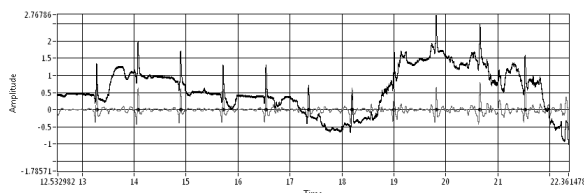

FIGURE 4. ECG signal picked up with arm movement, before and after filtering

Although the textile electrodes can be used as dry electrodes, the signal quality significantly improves when using conductive gel, or even water. The

sweat also contributes to reduce the impedance between skin and electrode.

Movement is an important factor when measuring electric potentials, since the electrodes may capture other potentials that have an origin on muscles in the vicinity of those electrodes. Moreover, the electrodes may lose contact with skin, or even change their position due to bending of the chest while swimming (or other exercise). To avoid these problems, standard electrodes have an adhesive conductive gel that guarantees a good contact and low skin-electrode impedance. ECG electrodes made of silver chloride used on training have a very powerful adhesive, which presents as inconvenient the fact of skin irritation after removal. This approach was not adopted in our swimsuit. Instead we decided to carefully choose the most adequate compression in order to guarantee a good contact during exercise and reducing the risk of changing the position.

The electrodes are robustly interconnected to isolated electric wires. Experiments made until now proved that the connection adopted is robust enough to support consecutive dressing and undressing operations.

The electrodes developed for EMG were based on SENIAM [12] recommendations, with a 10 mm dimension and with a distance of 20 mm between each other. The construction is similar to ECG electrodes, except for the size. As it can be seen in Figure 5, the EMG electrodes were embedded in the knitted fabric with the purpose of measuring the following muscles: Peroneus Longus, Rectus Femoris, Vastus Lateralis and Gastrocnemius Lateralis. The conductive yarns, that are firmly connected to these electrodes travel in a specific path along the leg, in Peroneus Longus and Vastus Lateralis side, connecting to the conditioning modules located on the belly .



FIGURE 5. BIOSWIM swimsuit detail with the EMG sensors embedded in the knitted fabric.

The two right side illustrations on Figure 5 show the EMG electrodes on the arm, for measuring Flexor digitorum superficialis, Biceps brachii, Triceps brachii and Deltoideus. The conductive yarns are placed in the exterior part of the arm but inside the swimsuit, where the risk of extension of those wires is reduced. It is possible to produce arrays of electrodes using this approach, which is a task that is presently under development.

The electronics connected to the electrodes is based on a low power instrumentation amplifier connected to two analog filters, a high-pass filter before the amplification stage, with the objective of reducing slow fluctuations produced by movements and varying polarization potentials on the electrodes, and a low-pass filter located after the amplifying stage with the purpose of reducing frequencies above 600 Hz. The conditioning system is then connected to the Jennic's module, which is responsible for data logging and wireless transmission to the coordinator of the zigbee network. ECG is based on a similar design, but with different amplification and cut-off frequencies.

#### **COMPARISON OF SIGNALS OBTAINED WITH THE TEXTILE ELECTRODES AND CONVENTIONAL ELECTRODES**

The electrodes were characterized in terms of skin to electrode impedance, based on the method proposed by Spach et al. [11] However, due to the unique characteristics of weft knitted fabrics, namely its stretch ability, the electrodes were also tested in a relaxed state and with predefined extensions when wrapped around the arm, both in wale and course directions, until their maximum allowable extension, to simulate the effect of being stretched when dressed. Different electrode sizes were also tested, as well as two different types of conductive yarns. One of the most interesting results is that skin-

electrode impedance tends to reduce as the textile electrode is stretched and consequently compressed against the skin. This reinforces the importance of compression, as it will promote a better contact with skin, reduce the movement of the electrode and will stretch it, thus improving skin-electrode impedance.

With the purpose of testing the electrodes in terms of quality of signal, tests involving the comparison of the developed electrodes with conventional electrodes were conducted. The following sections will present some of the results obtained.

#### **EMG signals**

The embedded electrodes used for EMG were compared with a specialized EMG measurement system, BIOPAC model MP100A. The signals were collected by the same acquisition software and then treated with MATLAB. The experiment acquired EMG signals from the Rectus Femoris of a young athlete using a BIODEX equipment, during five repetitions of iso-kinetic flexion and extension, with a controlled speed of 90°/s. The electrodes were compared individually, and then simultaneously, by attaching the conventional electrodes to the skin, under the swim vest and as close as possible to the embedded electrodes. The signal was acquired at a sample rate of 1000 Hz. Figure 6 illustrates the results obtained with conventional electrodes, and the textile electrodes proposed for this swimsuit. It can be observed that there is a difference in amplitude and some spikes in the signal on figure 6. It is important to note the low level in noise. One important difference between the conventional and the textile electrodes is the bonding to the skin. The conventional electrodes are made of silver chloride, have an excellent conductive gel and an adhesive layer. Moreover, additional contact is promoted by the fact of being under the garment. This can be compared to the embedded electrodes which use only a commercially available conductive gel with no adhesive, and rely exclusively on compression by the material itself. These differences may in part explain what is observed in the two pictures in Figure 6.

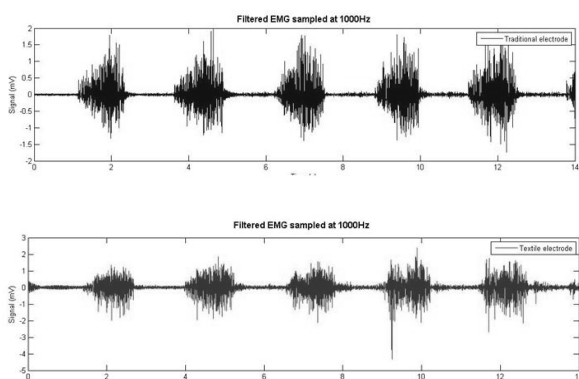

FIGURE 6. Resulting EMG signals for the test described using BIODEX system. The top image refers to conventional electrodes, while the bottom image refers to textile electrodes.

Acquiring the signals simultaneously with the conventional electrodes and the textile electrodes during the exercise resulted in the figures depicted below.

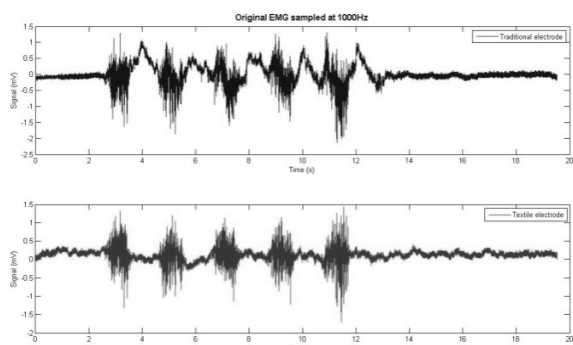

FIGURE 7. Simultaneous acquisition of EMG signals with conventional (top) and textile (bottom) electrodes during isokinetic flexion of the leg. Notice the artifacts produced by intense leg movement on both sensors.

It is quite interesting to observe that the artifacts seem to be less important in the textile based electrodes than in the conventional ones. This could be caused by the fact that conventional electrodes are attached instead of being embedded. After filtering the signal remains as follows.

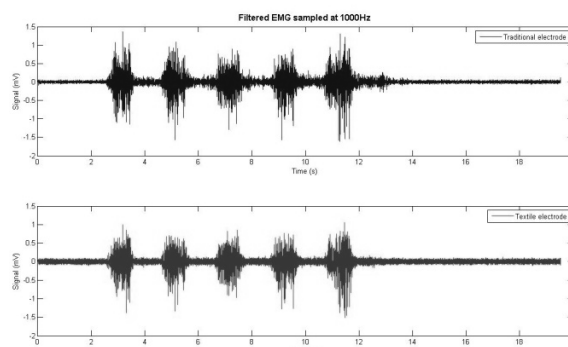

FIGURE 8. Resulting EMG waveforms after proper filtering: conventional electrodes on top and textile electrodes in bottom.

It is possible to observe a higher noise envelope before movement using the textile electrodes, however it is clear that there are similarities between both signals. The moving RMS filtered signal that is generally used on EMG resulted in very similar curves, presenting a correlation coefficient of 98%.

### ECG Signals

For the comparison of the ECG signal acquired with conventional electrodes and the textile electrodes, a NORAV system was used. Since it was not possible to use an identical derivation from the NORAV as the one acquired with the BIOSWIM system, NORAV's DII derivation was used. After acquisition and sending the signal to the computer, digital processing is used, namely a notch filter between 49 and 51 Hz (to eliminate the noise generated by power lines) and a pass-band filter between 1 and 100 Hz, restricting the signal bandwidth. The signal obtained (figure 9), albeit the obvious differences, namely on the negative ST segment present high similarities and behavior. It also presents an excellent noise level, thus allowing to further develop tools concerning special diagnostics during intense exercise. The low noise level is also due to the position of the textile electrodes sensors, which avoids the position of muscles.

The intense movement results in a signal that seems to be a very confusing one. However, by applying additional filtering, similar to the frequencies mentioned above, the artifacts are

eliminated and the signal becomes intelligible again, as it can be confirmed in figure 4.

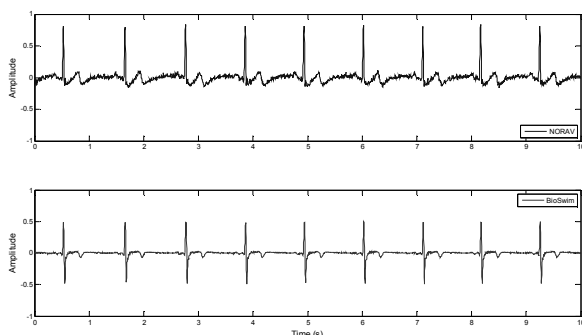

FIGURE 9. ECG waveforms obtained for conventional electrodes, measured with NORAV system (top image) and textile electrodes using BIOSWIM system (bottom image).

## CONCLUSIONS

This paper presented an overview on some aspects regarding the development of an autonomous swimsuit that is equipped with several sensors, for performance evaluation of a swimmer. The paper discusses in particular the process of integrating textile electrodes for biopotential measurement using a particular knitting machine, its advantages and presents some results obtained using those sensors. Being an autonomous swimsuit, the communication system was also briefly described, which is based on a wireless network using Zigbee that transmits the data into a laptop computer.

The most important advantage of this swimsuit with integrated electrodes is the swimmer's comfort. In fact, unobtrusive electrodes are worn by the swimmer without any particular discomfort while dressing and using the instrumented garment, and are readily placed in the correct position when the swimmer puts the swimsuit on.

The proposed textile electrodes were tested and compared with conventional electrodes using standard EMG and ECG signal acquisition methods, which allowed to confirm the similarity and quality of the signals obtained with textile electrodes, both for ECG as well as for EMG, which can thus replace with success the conventional electrodes with an increased comfort to the wearer.

A valid textile-based biopotential acquisition system for sports performance monitoring has thus been demonstrated in this work.

## ACKNOWLEDGEMENTS

The authors wish to thank FCT, which is funding this research through project number PTDC/EEA-ELC/70803/2006.

## REFERENCES

- [1] Xu, P. J., Zhang, H. and Tao, X. M., "Textile-structured electrodes for electrocardiogram", *Textile Progress*, 40:4, 183 — 213, 2008
- [2] J. Coosemans, B. Hermans, R. Puers, "Integrating wireless ECG monitoring in textiles", *Sensors and Actuators A* 130–131, 48–53, 2006
- [3] E. Scilingo, A. Gemignani, R. Paradiso, N. Taccini, B. Ghelarducci, D. De Rossi, "Performance Evaluation of Sensing Fabrics for Monitoring Physiological and Biomechanical Variables", *IEEE Transactions on Information Technology in Biomedicine*, VOL. 9, NO. 3, 345-352, 2005
- [4] C. Hertleer, M. Grabowska, L. Van Langenhove, M. Catrysse, B. Hermans, R. Puers, A. Kalmar, H. van Egmond, D. Matthys, "The use of electroconductive textile material for the development of a smart suit", *World Textile Conference - 4th AUTEX Conference* Roubaix, June 22-24 2004
- [5] Linti, H. Horter, P. Österreicher, H. Planck, "Sensory baby vest for the monitoring of infants", *Proceedings of the International Workshop on Wearable and Implantable Body Sensor Networks (BSN'06)*, 2006
- [6] Gonçalves, P.; Pereira, S., Vilar, S.; Figueiredo, P.; Sousa, A.; Fernandes, R., Vilas-Boas, J.P., "Underwater electromyography system and his dialog with other instrumentation". *10th International Symposium and Medicine in Swimming. Rev. Port. Ciências do Desporto*, 6 (Supl. 1): 21, 2006
- [7] Silva, M., Catarino, A., Carvalho, H., Rocha, A., Monteiro, J., Montagna, G., "Study of vital sign monitoring with textile sensor in swimming pool environment". *Proceedings of the IEEE IECON 2009*, 2009
- [8] Silva, M., Catarino, A., Carvalho, H., Rocha, A., Monteiro, J., Montagna, G., Textile sensors for ECG and respiratory frequency on swimsuits", *Proceedings of the Conference on Intelligent Textiles and Mass Customisation*, 2009
- [9] Montagna, G., Catarino, A., Carvalho, H., Rocha, A., "Study and optimization of swimming performance in swimsuit designed with Seamless Technology", *Autex 2009 World Textile Conference*, 2009
- [10] M. Catrysse, R. Puers, C. Hertleer, L. van Langenhove, H. van Egmond, D. Matthys, "Towards the integration of textile sensors in a wireless monitoring suit", *Sensors and Actuators A* 114, 302–311, 2004
- [11] M. SPACH, R. BARR, J. HAVSTAD, E. CROFT LONG, "Skin-Electrode Impedance and Its Effect on Recording Cardiac Potentials", *Circulation, Journal of The American Heart Association*, 649-656, 1966
- [12] SENIAM - Surface ElectroMyoGraphy for the Non-Invasive Assessment of Muscles *European Project*