

Exposto, B.; Carneiro, H.; Pinto, G.; Couto, C.; Afonso, J.L., "Simulations of a current-source Shunt Active Power Filter with Carrier-Based PWM and Periodic Sampling Modulation Techniques", *Proceedings of the 2011-14th European Conference on Power Electronics and Applications (EPE 2011)*, pp.1-8, 30 Aug. - 1 Sept., 2011.

Simulations of a Current-Source Shunt Active Power Filter with Carrier-Based PWM and Periodic Sampling Modulation Techniques

Bruno Exposto, Helder Carneiro, Carlos Couto, João L. Afonso

UNIVERSITY OF MINHO

Department of Industrial Electronics

4800-058 - Guimarães, Portugal

Tel.: +351 253 510 190.

Fax: +351 253 510 189.

E-Mail: bexposto@dei.uminho.pt, hcarneiro@dei.uminho.pt, carlos.couto@dei.uminho.pt
jla@dei.uminho.pt

URL: <http://www.gepe.dei.uminho.pt>

Acknowledgements

This work is financed by FEDER Funds, through the Operational Programme for Competitiveness Factors – COMPETE, and by National Funds through FCT – Foundation for Science and Technology of Portugal, under the project PTDC/EEA-EEL/104569/2008.

Keywords

Current Source Inverter (CSI), Active Power Filter, Power Quality, Modulation Strategy, Simulation, Pulse Width Modulation (PWM).

Abstract

This paper presents a Shunt Active Power Filter that is built using a current-source inverter. The control of the Active Filter relies in the p-q Theory with the “Sinusoidal Currents at Source” algorithm implemented. The Active Power Filter was simulated using two modulation techniques: Periodic Sampling and Carrier-Based Pulse Width Modulation (CBPWM). To assess the performance of the Active Filter, the simulations were made using two different loads. The first load was a RL balanced load. The second was a non-linear load, namely a full bridge rectifier with a RL load in the DC side. These loads allowed determining the performance of the Active Filter when compensating current harmonics and power factor, using the two modulation techniques.

Introduction

Non-linear loads are very common in the industrial installations nowadays. These types of loads consume currents with high levels of harmonic content, which causes Power Quality problems. In addition, the existence of industrial facilities with low power factor causes problems related with energy efficiency and overdimensioning of cables. All these problems represent economical wastes and as said before reduction of energy efficiency. The conventional solutions used for solving and mitigate these problems, such as tuned passive filters for current harmonics and capacitor banks for power factor correction, do not solve them in a suitable way, and can cause other problems, such as resonances. Therefore, it is necessary to find new solutions to these problems. Shunt Active Power Filters are a more suitable solution that allows the dynamic compensation of current harmonics and power factor, without causing the problems that the passive filters and capacitor banks can cause. The Active Filters are traditionally built using voltage-source inverters. Differently from the conventional solutions, in this paper is presented a Current-Source Shunt Active Power Filter. In the last few years there has been growing research on Current-Source Active Filters [1] [2], but it is still necessary to perform studies of their operation under different types of loads and inverter modulation techniques.

The proposed Current-Source Shunt Active Filter was simulated using two modulation techniques: Periodic Sampling and Carrier-Based Pulse Width Modulation (CBPWM). These two modulation techniques have been successfully used in Voltage-Source Active Filters [3]. The control technique of

the Active Power Filter relies in the p - q Theory with the “Sinusoidal Source Currents” algorithm implemented. The regulation of the DC link current is done also with the p - q Theory. The results of the simulated Active Power Filter operating with Carrier-Based PWM and Periodic Sampling were compared to assess the operating performance differences.

Current-Source Active Filter Configuration

Simulated Inverter Topology

As mentioned above the Active Power Filter is based in a current-source inverter. The inverter has six IGBTs and six diodes placed in series with the IGBTs (Fig. 1). The diodes placed in series with the IGBTs are necessary due to the fact that during the normal operation of the inverter the power switches must withstand direct and reverse voltages (u_{dc} and $-u_{dc}$) produced by the DC inductor.

In the DC side of the Active filter was placed an inductor in series with a resistor to simulate a real inductor and to assess power losses influence in the performance of the Active Filter. The inverter is connected in parallel with the load using LCR low pass passive filters.

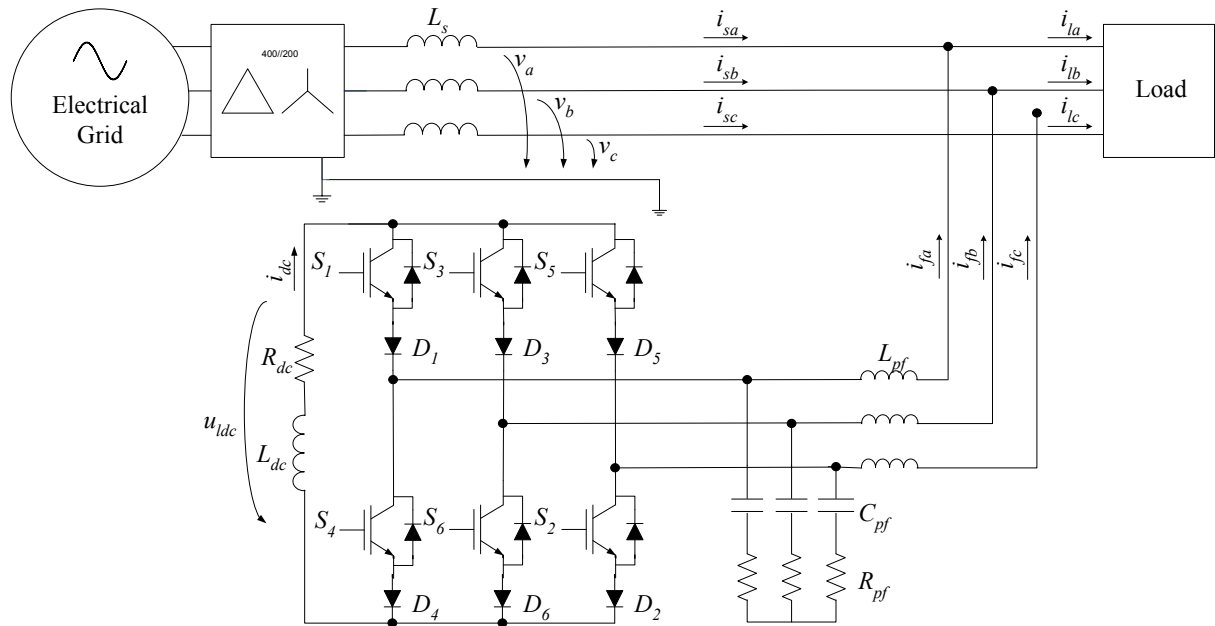

Fig. 1: Simulated Current-Source Active Power Filter topology.

The LCR low pass passive filters values are the same in the simulations done for the two modulation technics. The characteristics of the passive filter can be seen in Table II.

Table II: LCR passive filters characteristics

C_s	L_s	R_s	Resonance Frequency
50 μ F	0.3 mH	3 Ω	1299 Hz

Control Scheme

The control of the Shunt Active Power Filter relies in the p - q Theory proposed by *Akagi et al.*[4], with the “Sinusoidal Source Currents” algorithm implemented. The use of the p - q Theory in the control of Voltage-Source Active Filters is quite widespread [5][6], but in Current-Source Active Filters the use of this theory is very limited. To use the p - q Theory with the “Sinusoidal Source Currents” algorithm, it was implemented a Phase-Lock Loop Circuit (PLL) that extracts the positive sequence values of the system voltages (v_{a_pll} , v_{b_pll} , v_{c_pll}). The values of those voltages and of the system currents are converted to a α - β reference frame applying the appropriate α - β transformation (1)(2) respectively.

$$\begin{bmatrix} v_\alpha \\ v_\beta \end{bmatrix} = \sqrt{\frac{2}{3}} \cdot \begin{bmatrix} 1 & -1/2 & -1/2 \\ 0 & \sqrt{3}/2 & -\sqrt{3}/2 \end{bmatrix} \cdot \begin{bmatrix} v_a \\ v_b \\ v_c \end{bmatrix} \quad (1)$$

$$\begin{bmatrix} i_\alpha \\ i_\beta \end{bmatrix} = \sqrt{\frac{2}{3}} \cdot \begin{bmatrix} 1 & -1/2 & -1/2 \\ 0 & \sqrt{3}/2 & -\sqrt{3}/2 \end{bmatrix} \cdot \begin{bmatrix} i_a \\ i_b \\ i_c \end{bmatrix} \quad (2)$$

The instantaneous real power, p and the instantaneous imaginary power, q , are calculated in the new reference frame (3).

$$\begin{bmatrix} p \\ q \end{bmatrix} = \begin{bmatrix} v_\alpha & -v_\beta \\ v_\beta & v_\alpha \end{bmatrix} \cdot \begin{bmatrix} i_\alpha \\ i_\beta \end{bmatrix} \quad (3)$$

Then, through a sliding average algorithm, is obtained the mean value of the instantaneous real power, (\bar{p}). Using p and \bar{p} is possible to obtain the alternating value of the instantaneous real power.

The DC link inductor current is controlled by a Proportional-Integrative (PI) controller that generates a p_{reg} signal, which is the instantaneous real power necessary to regulate the DC link current. The DC link current is fixed, so it is necessary to previously determine the amplitude of the loads currents that will be compensated, to adjust the value of the DC link current reference.

The values of \bar{p} , p_{reg} and q are then used to calculate p_x and q_x (4) (5).

$$p_x = \bar{p} - p_{reg} \quad (4)$$

$$q_x = q \quad (5)$$

Using p_x and q_x it is possible to determine the α - β reference currents that should be generated by the Active Filter inverter (6).

$$\begin{bmatrix} i_{c\alpha} \\ i_{c\beta} \end{bmatrix} = \frac{1}{v_\alpha^2 + v_\beta^2} \cdot \begin{bmatrix} v_\alpha & -v_\beta \\ v_\beta & v_\alpha \end{bmatrix} \cdot \begin{bmatrix} p_x \\ q_x \end{bmatrix} \quad (6)$$

The compensating reference currents $i_{c\alpha}$ and $i_{c\beta}$ are then converted to the a - b - c coordinates system and used in the modulator. All the control processes is specified in Fig. 2.

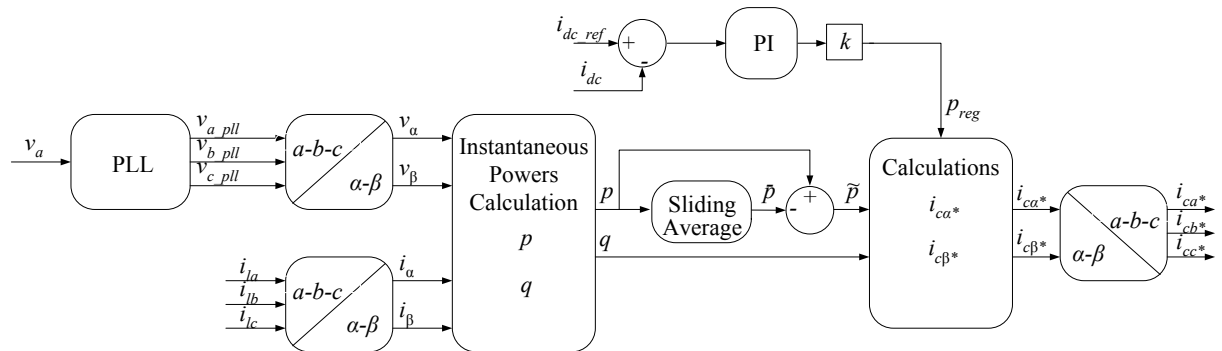

Fig. 2: Control scheme of the Current-Source Shunt Active Power Filter.

Current Control Strategies and Switching Techniques

The current-source inverter has two operating restrictions: the DC link inductor current must not be interrupted; and the AC side of the inverter must not be short-circuited [7]. Due to these restrictions there are some inverter states that cannot be used when the currents are being synthesized, and thus, the switching pattern generator must prevent the use of these invalid states. The Active Power Filter was simulated using Periodic Sampling (PS) and Carrier-Based Pulse Width Modulation (CBPWM) and to respect the valid states of the inverter was implemented one combinational logic circuit similar to that referred in [7].

Carrier-Based PWM Switching Pattern Generator

The switching CBPWM pulses are generated subtracting the inverter currents (i_{fa} , i_{fb} , i_{fc}) with the reference compensating currents (i_{ca}^* , i_{cb}^* , i_{cc}^*). The resulting error is sent to a PI controller. Then the output signal of the PI controller is compared with a triangular carrier with a frequency of 16 kHz. The result of that comparison is sent to the combinational logic circuit (Fig. 3).

Periodic Sampling Switching Pattern Generator

The switching PS pulses are generated comparing the reference compensating currents (i_{ca}^* , i_{cb}^* , i_{cc}^*) with the inverter currents (i_{fa} , i_{fb} , i_{fc}) and the result of this comparison is sent to a combinational logic circuit similar to the one used in the CBPWM pattern generator (Fig. 4). To ensure that the IGBTs are actuated at the sampling frequency, in the output of the combinational circuit are placed D type flip-flops. The clock frequency of the D-type flip-flop corresponds to the sampling frequency of 16 kHz. This frequency is the maximum switching frequency of the IGBTs.

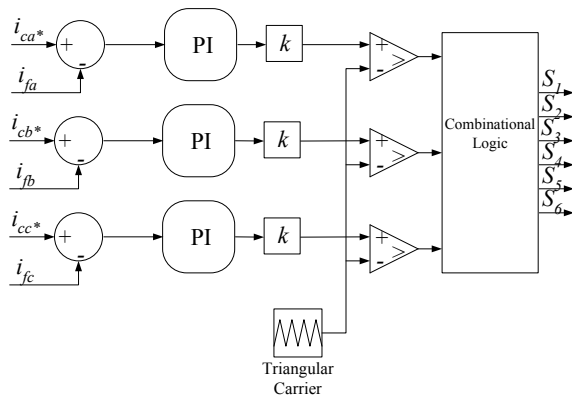

Fig. 3: Carrier-Based PWM switching pattern generator scheme.

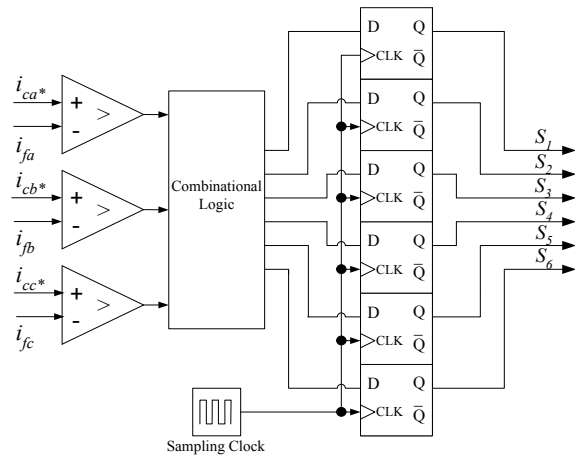

Fig. 4: Periodic Sampling switching pattern generator scheme.

Simulation Parameters

The simulations of the Current-Source Shunt Active Filter were made using the PSCAD software from Manitoba HVDC Research Centre Inc. In this simulation model the Active Filter and the loads were connected to transformer 400//200 50 Hz. To simulate the line impedance it was placed in each phase an inductor of 1.1 mH. It was used in the simulations two different types of loads: the first one a three-phase balanced resistive-inductive load connected in delta, with an inductor of 146 mH and a 25 Ω resistor; and the second one a three-phase full bridge rectifier, with a resistor of 37.5 Ω placed in series with an inductor of 146 mH in the DC side. These two loads allow assessing the performance of the Current-Source Active Filter when compensating a low power factor load and a non-linear load. The DC link inductor current was adjusted to 8 A for all the simulations. This value is adequate to the values of the loads currents present in the simulations and the losses in the DC link inductance.

Simulation Results

Current-Source Shunt Active Power Filter Compensating a RL Load

In Fig. 5 it can be seen that the Current-Source Shunt Active Filter can compensate loads with low power factor using CBPWM and PS. Fig. 5 a) shows source current (i_{sa}) and system voltage (v_a) before the compensation. The source current (i_{sa}) after the compensation is in phase with the system voltage (v_a) confirming that the compensation is being done correctly in both cases (Fig. 5 a b)). Also the amplitude of the source current is in both cases diminished after the compensation. Although this, in the case which is used PS (Fig. 5 c)) the source current (i_{sa}) and system voltage (v_a) are more distorted after the compensation, than in the case which is used CBPWM (Fig. 5 b)). These observations are confirmed in Table III.

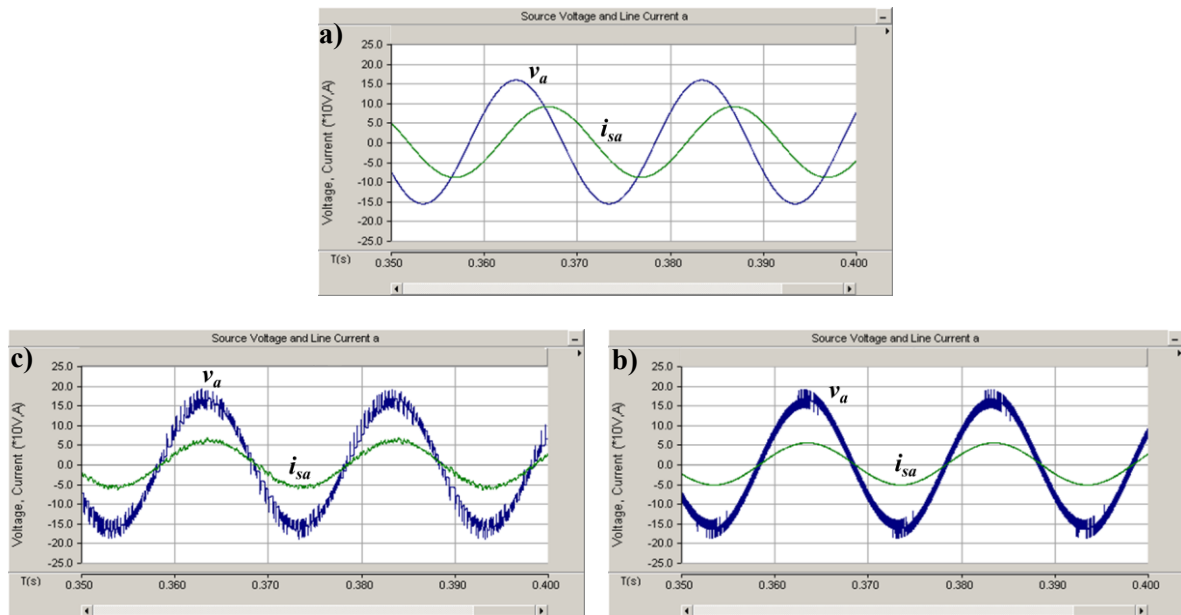

Fig. 5: a) Phase a voltage (v_a) and source current (i_a) without compensation; b) Current Source Active Filter compensating a RL load using CBPWM; c) Current Source Active Filter compensating a RL load using PS.

Table III: Simulation results of the Active Filter compensating a RL load

Power Factor			Voltage THD			Current THD		
Without Compensation	CBPWM	PS	Without Compensation	CBPWM	PS	Without Compensation	CBPWM	PS
0.48	1	1	0	4,0%	8,0%	0	0.8%	7.6%

DC Link Inductance Current Regulation

The control of the Active Filter is capable of successfully regulate de DC link inductor when is used CBPWM and PS, to compensate the RL load (Fig. 6). When the Active Filter is using PS (Fig. 6 b)), the ripple of the DC link current is higher to the case when is used CBPWM (Fig. 6 a)).

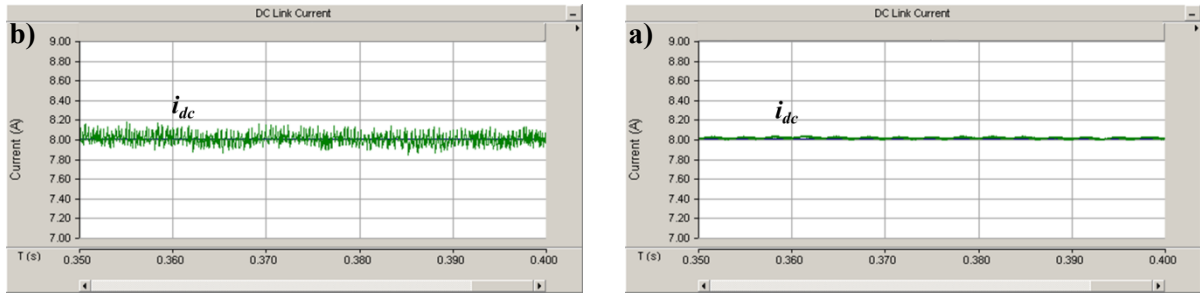

Fig. 6: DC link inductance current regulation when compensating RL load - current reference (i_{dc_ref}) and measured current (i_{dc}): a) Current Source Active Filter using CBPWM; b) Current Source Active Filter using PS.

Due to the fact that the DC link inductance current ripple is higher in the simulation of the Active Filter operating with PS, the voltage spikes produced in the DC link inductor are more recurrent over time (Fig. 7 b)). Although this, the maximum amplitude of the voltage spikes is similar in the two simulations

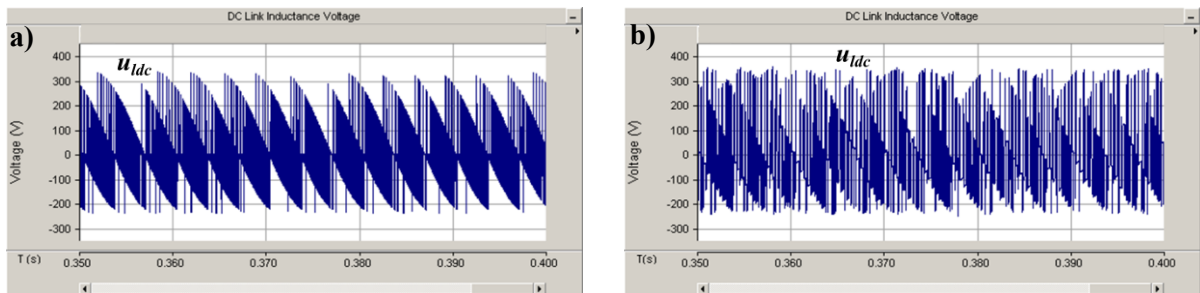

Fig. 7: DC link inductance voltage (v_{ldc}): a) Current Source Active Filter compensating a RL load using CBPWM; b) Current Source Active Filter compensating a RL load using PS.

Current-Source Active Filter Compensating a Non-Linear Load

In Fig. 6 it can be seen that the Current-Source Shunt Active Filter can compensate non-linear loads. Fig. 6(a) shows the system voltage (v_a) and the source current (i_{sa}) without compensation, Fig. 6(b) shows v_a and i_{sa} when the Active Filter uses Periodic Sampling as modulation technique and Fig. 6(c) shows v_a and i_{sa} when the Active Filter uses CBPWM as modulation technique.

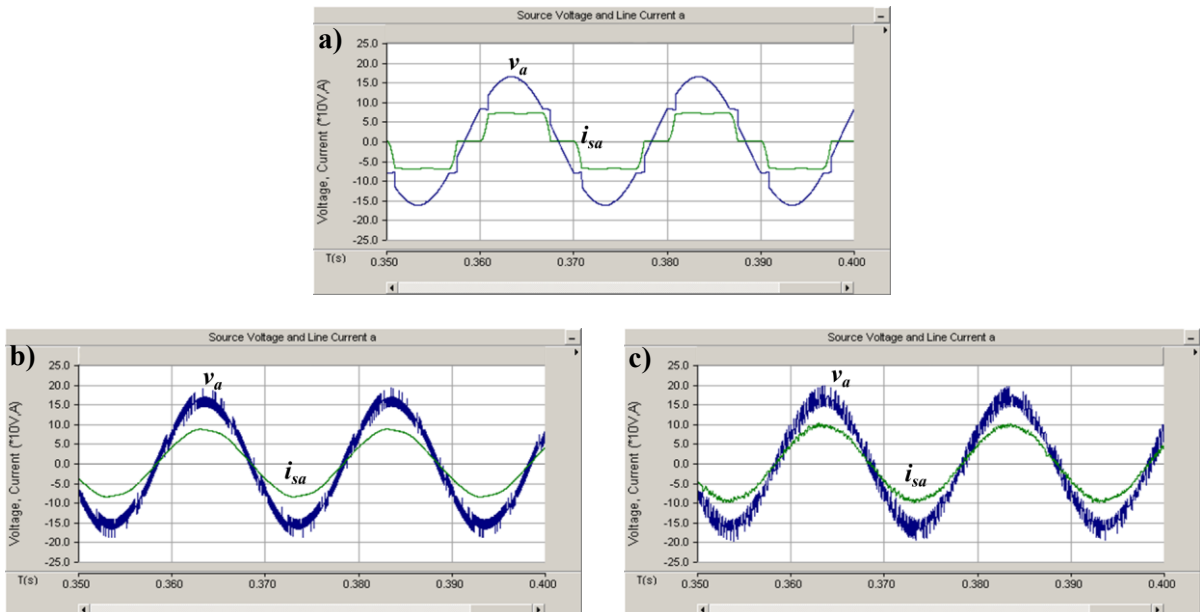

Fig. 8: a) Phase a voltage (v_a) and source current (i_a) without compensation; b) Current Source Active Filter compensating a non-linear load using CBPWM; c) Current Source Active Filter compensating a non-linear load using PS.

It is observed that the Current-Source Shunt Active Filter can effectively compensate the full bridge rectifier currents, and the performance of the Active Filter is similar in both cases of compensation. The differences of performance are associated with the voltage and current THD after the compensation. In the case of the simulations in which the Active Filter operates with PS, the voltage and current THD after the compensation are higher than in the simulations in which the Active Filter operates with CBPWM (Table IV).

Table IV: Simulation results of the Active Filter compensating a non-linear load

Power Factor			Voltage THD			Current THD		
Without Compensation	CBPWM	PS	Without Compensation	CBPWM	PS	Without Compensation	CBPWM	PS
0.99	1	1	7.0%	3.5%	5.2%	25,0%	1.7%	3.5%

DC Link Inductance Current Regulation

The control of the Active Filter is capable of successfully regulate de DC link inductor when is used CBPWM and PS, to compensate the RL load. Due to the fact that the Active Filter is compensating current harmonics, the ripple of the DC link inductance current is higher than in the other performed simulations. Even though, when the Active Filter is using PS (Fig. 9 b)) the ripple of the DC link current is higher than the case when is used CBPWM (Fig. 9 a)).

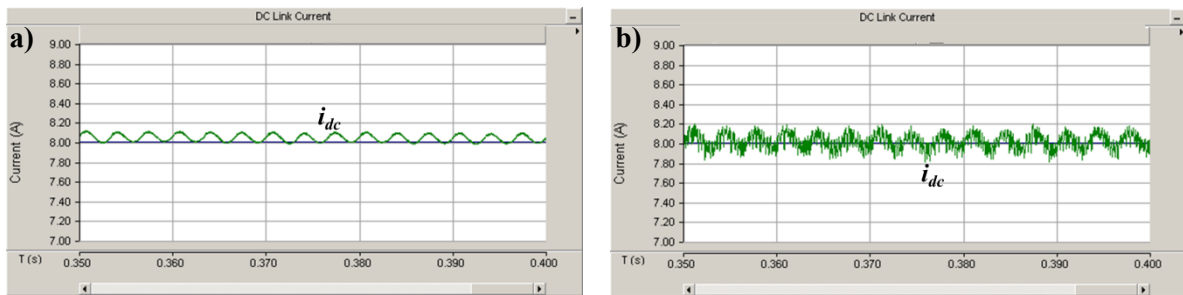

Fig. 9: DC link inductance current regulation when compensating a non-linear load: a) Current Source Active Filter load using CBPWM; b) Current Source Active Filter using PS.

As before, the voltage spikes produced in the DC link inductor in the simulations where the Active Filter operates with PS are more recurrent over time (Fig. 10 b)). Also in this case the amplitude of those voltage spikes is slightly higher than in the simulations where the Active Filter operates with CBPWM.

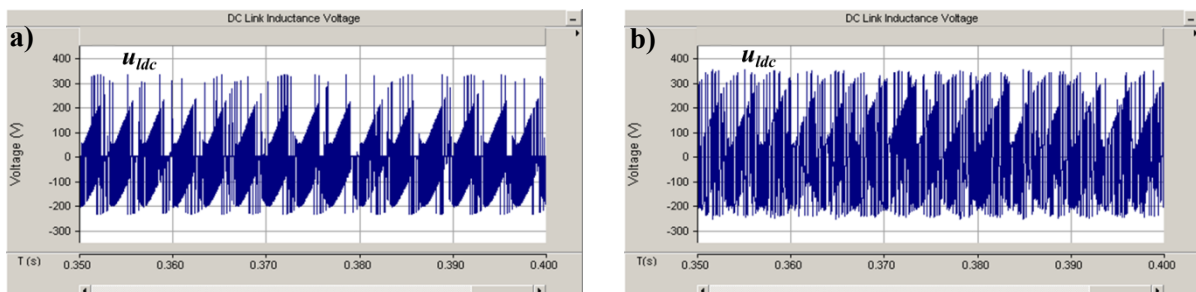

Fig. 10: DC link inductance voltage (v_{dc}): a) Current Source Active Filter compensating a RL load using CBPWM; b) Current Source Active Filter compensating a RL load using PS.

Conclusion

Shunt Active Power Filters are a good solution that allows the dynamic compensation of current harmonics and power factor. In recent years there has been intensive research in Voltage Source Active Filters but Current Source Active Filters are also a solution to solve current harmonics and power factor, although there is less research in this field.

In this paper were presented simulations results of a Current-Source Shunt Active Filter operating with Carrier-Based Pulse Width Modulation (CBPWM) and Periodic Sampling (PS). The simulation results show that Current Source Active Filters can operate with both modulation techniques, but the source currents and system voltages have higher THD values after the compensation, when the Active Filter operates with PS. The $p-q$ Theory can be successfully used to regulate the DC link inductance current at the same time that provides the compensating reference currents. Further research will allow developing a control that automatically adjusts the DC link current, using the $p-q$ Theory.

References

- [1] Mika Salo, Heikki Tuusa, "A Current-Source Active Power Filter with a Control Delay Compensation", Power Electronics Specialists Conference, PESC.01, 2001, Vancouver, Canadá, vol. 3, pp 1591-1595.
- [2] Pettersson, S.; Salo, M.; Tuusa, H.; , "Optimal DC current control for four-wire current source active power filter," Applied Power Electronics Conference and Exposition, 2008. APEC 2008. Twenty-Third Annual IEEE , vol., no., pp.1163-1168, 24-28 Feb. 2008.
- [3] J. W. Dixon, S. Tepper, L. Moran, "Analysis and Evaluation of Different Modulation Techniques for Active Power Filters", Proc. IEEE APEC'94, pp.894 - 900, 1994.
- [4] H. Akagi, Y. Kanazawa, A. Nabae, Generalized Theory of the Instantaneous Reactive Power in Three-Phase Circuits, IPEC'83 - Int. Power Electronics Conf., Tokyo, Japan, 1983, pp. 1375-1386.
- [5] João L. Afonso, Carlos Couto, Júlio Martins, "Active Filters with Control Based on the p-q Theory", IEEE Industrial Electronics Society Newsletter vol. 47, n.º 3, Set. 2000, ISSN: 0746-1240, pp. 5-10.
- [6] João L. Afonso, Maurício Aredes, Edson Watanabe, Júlio Martins, "Shunt Active Filter for Power Quality Improvement", International Conference UIE 2000 - "Electricity for a Sustainable Urban Development", Lisbon, Portugal, 1-4 November 2000, pp. 683-691.
- [7] Muhammad M. Rashid, Power Electronics Handbook, 2001, Academic Press.
- [8] João L. Afonso, Carlos Couto, Júlio Martins, "Active Filters with Control Based on the p-q Theory", IEEE Industrial Electronics Society Newsletter, vol. 47, n.º 3, Sept. 2000, pp. 5 10.
<http://repositorium.sdum.uminho.pt/handle/1822/1921>