



ASSESSMENT OF THE EFFECTIVENESS OF NSM-CFRP FLEXURAL STRENGTHENING CONFIGURATIONS FOR CONTINUOUS RC SLABS



**Matteo
Breviglieri**



**Joaquim A.O.
Barros**



**Gláucia M.
Dalfré**



**Alessandra
Aprile**

Abstract

The experimental programs for the flexural strengthening of reinforced concrete (RC) structures using the Near Surface Mounted (NSM) technique with Fiber Reinforced Polymer (FRP) laminates were, in general, conducted with simply supported beams. Therefore, there is a lack of experimental and theoretical studies on the moment redistribution of statically indeterminate RC elements strengthened with NSM technique. This work explores the influence of the amount of FRP in terms of load carrying capacity, ductility and moment redistribution capacity of continuous RC slab strips. In this way, two span slab strips strengthened in the hogging region were tested. The obtained results were used to assess the predictive performance of a finite element model in the simulation of the nonlinear behavior of the tested slabs. Finally, a parametric study is carried out to investigate the influence of the strengthening arrangement and FRP percentage in terms of load carrying capacity and moment redistribution capacity of continuous RC slab strips flexurally strengthened by the NSM technique.

Keywords: NSM strengthening technique, CFRP laminates, flexural strengthening, RC continuous slabs, Moment Redistribution, Plastic rotation capacity

1 Introduction

Extensive research has been conducted on the strengthening of reinforced concrete (RC) structures by using the Externally Bonded Fiber Reinforced Polymer reinforcement technique (FRP-EBR). The available research in this topic has revealed that RC elements strengthened by means of FRP-

EBR systems tend to fail by brittle premature plate debonding, well before the FRP tensile strength capacity is reached (Vasseur *et al.* 2007, El-Rafaie *et al.* 2004, Oehlers *et al.* 2004, Aiello *et al.* 2007). The premature debond and the linear-elastic brittle failure behaviour of the FRP-based strengthening systems can be a serious restriction in their use for the flexural strengthening of statically indeterminate RC structures due to the restrictions they impose in terms of load carrying capacity, ductility and moment redistribution these FRP systems can provide. The recent achievements in the flexural strengthening effectiveness of the Near Surface Mounted technique (NSM) have expanded the potentialities of FRP systems for new types of applications (Barros and Kotynia, 2008). Tests on simply supported RC members strengthened with NSM Carbon FRP (CFRP) laminates have shown that NSM laminates debond at much higher strains than EBR CFRP strengthening systems, and, in certain cases, they can even fail by rupture (Blaschko 2003, Barros and Fortes 2005, Barros *et al.* 2007). Therefore, NSM strengthened members are expected to have a much more ductile behavior than EBR strengthened members. Since the majority of the tests carried out with NSM strengthened members have been executed with simply supported beams and slabs, there is a lack of experimental and theoretical studies on the effectiveness of the NSM technique, in particular in the moment redistribution capacity of statically indeterminate RC members flexurally strengthened with the NSM technique. Relevant studies on continuous RC members strengthened with NSM technique were conducted by Liu (2005), Liu *et al.* (2006) and Bonaldo (2008). To contribute for a better understanding of the influence of the strengthening arrangement (hogging, sagging or both regions) and percentage of FRP in terms of load carrying capacity, moment redistribution capacity and ductility performance, a parametric study was carried out. This parametric study was performed by executing nonlinear analysis with a computer program based on the Finite Element Method (FEM), whose predictive performance was appraised with the results obtained in an experimental program (Bonaldo, 2008).

2 The experimental program

2.1 Slab specimens and strengthening technique

To assess the effectiveness of the CFRP NSM flexural strengthening technique for the increase of the load carrying capacity of continuous RC slabs, an experimental program composed of nine 120×375×5875 mm³ RC two-span slabs was carried out by Bonaldo (2008). Three of them were unstrengthened RC slabs forming a control set (SL15, SL30 and SL45), and six slabs were strengthened with CFRP laminates according to the NSM technique (SL15s25, SL15s50, SL30s25, SL30s50, SL45s25 and SL45s50). The notation adopted to identify each slab specimen is SLx_{xy}, where SL is the slab strip base, x is the moment redistribution percentage, η (15%, 30% or 45%), s means that the slab is strengthened, and y is the target increase in the load carrying capacity (25% or 50%). **Fig. 1** shows the geometry of the slab strips and the strengthening arrangements for the SL15 series. A detailed description of the complete experimental program can be found elsewhere (Bonaldo, 2008). The steel reinforcement arrangements in the reference slabs were designed in compliance with ACI 318. According to this recommendation, at service, the maximum deflection of a slab should be limited to L/480 (L=2800 mm is the span length). Taking into account the concrete compressive strength applied in the tested slabs, the load F corresponding to this deflection is 50.82 kN. Furthermore, in the evaluation of the moment redistribution percentages, a strain limit of 3.5‰ for the concrete crushing was assumed. According to the CEB-FIB Model Code (1993), the coefficient of moment redistribution, $\delta = M_{red} / M_{elas}$, is defined as the relationship between the moment at the critical section after redistribution (M_{red}) and the elastic moment (M_{elas}) at the same section calculated according to the theory of elasticity, while $\eta = (1 - \delta) \cdot 100$ is the moment redistribution percentage. The NSM flexurally strengthened slabs had the same steel reinforcement arrangements adopted in the reference slabs of the corresponding series, and the number of 1.4×10 mm² cross sectional area CFRP laminates is designed to increase the load carrying capacity of the reference slabs in 25% or 50%. The design of cross sections subject to flexure was based on force and moment equilibriums, as well

as in strain compatibility, where the maximum strain at extreme concrete compression fiber was assumed equal to 3.5‰. Details on the material properties can be found elsewhere (Bonaldo, 2008). **Tab. 1** shows the arrangement of the steel reinforcement and the strengthening configuration of the tested slab strips. In this table, the equivalent reinforcement ratio, $\rho_{s,eq} = A_{sl} / bd_s + (A_f E_f / E_s) / (bd_f)$, is also indicated, where b is the slab strip width, d_s and d_f are the effective depth of the longitudinal steel bars and CFRP systems, respectively, A_f and E_f are the cross sectional area and the Young's Modulus of the CFRP systems, respectively, and A_{sl} and E_s are the cross sectional area and the Young's Modulus of the longitudinal tensile steel bars, respectively.

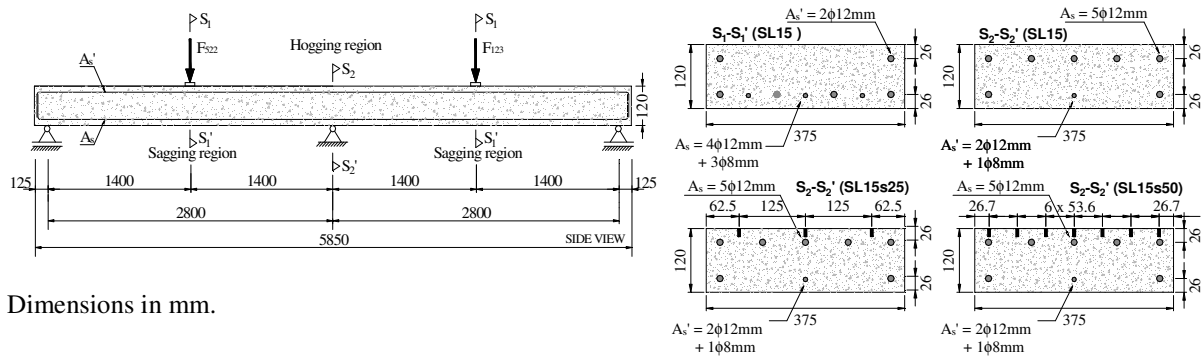

Dimensions in mm.

Fig. 1 SL15 series slab strips: Test configuration, cross-sectional dimensions and steel and CFRP arrangements.

Tab. 1 Geometry, reinforcement and strengthening details of the cross sections of the slab strips.

η	Increase of the load carrying capacity	Cross-Section S_1-S_1'	Cross-Section S_2-S_2'	Number of NSM CFRP laminates	$\rho_{s,eq}$ (%)
15%	Reference	$A_s' = 2\phi 12\text{mm}$	$A_s = 5\phi 12\text{mm}$	0	1.60
	25%	$A_s = 4\phi 12\text{mm} + 3\phi 8\text{mm}$	$A_s' = 2\phi 12\text{mm} + 1\phi 8\text{mm}$	3	1.68
	50%			7	1.78
30%	Reference	$A_s' = 2\phi 12\text{mm}$	$A_s = 4\phi 12\text{mm}$	0	1.28
	25%	$A_s = 3\phi 12\text{mm} + 4\phi 10\text{mm}$	$A_s' = 2\phi 10\text{mm} + 1\phi 12\text{mm}$	2	1.33
	50%			5	1.41
45%	Reference	$A_s' = 2\phi 10\text{mm}$	$A_s = 3\phi 10\text{mm} + 2\phi 8\text{mm}$	0	0.95
	25%	$A_s = 6\phi 12\text{mm} + 1\phi 8\text{mm}$	$A_s' = 2\phi 12\text{mm} + 1\phi 8\text{mm}$	1	0.98
	50%			3	1.03

Note: A_s' - compressive reinforcement, A_s - tensile reinforcement, CFRP laminates applied only in the hogging region.

2.2 Relevant results of the experimental program

The applied load (F) versus deflection curves of the tested slab strips of SL15 series are presented in **Fig. 2**. Additionally, **Tab. 2** presents the main results obtained experimentally. In this Table, $\Delta \bar{F}_{tar}$ is the target increase in terms of load carrying capacity provided by the strengthening technique at \bar{F}_{max} (maximum value of the average load registered in the load cells $F_{(522)}$ and $F_{(123)}$). From the analysis of the results, it can be noted that an average increase of 9% and 16% was obtained in terms of the load carrying capacity of the slabs strengthened, for an increase of 25% and 50%, respectively. In terms of moment redistribution percentage, η , for a compressive strain of 3.5‰ in the concrete surface at loaded sections, the following values of η were obtained: 17.5%, -3.9% and -14.8% for SL15, SL15s25, SL15s50; 36.4%, 25.3% and 14.92% for SL30, SL30s25, SL30s50; 53.0%, 42.8% and 30.8% for SL45, SL45s25, SL45s50. The moment redistribution capability is, therefore, negatively affected when the percentage of CFRP laminates increases in the hogging region.

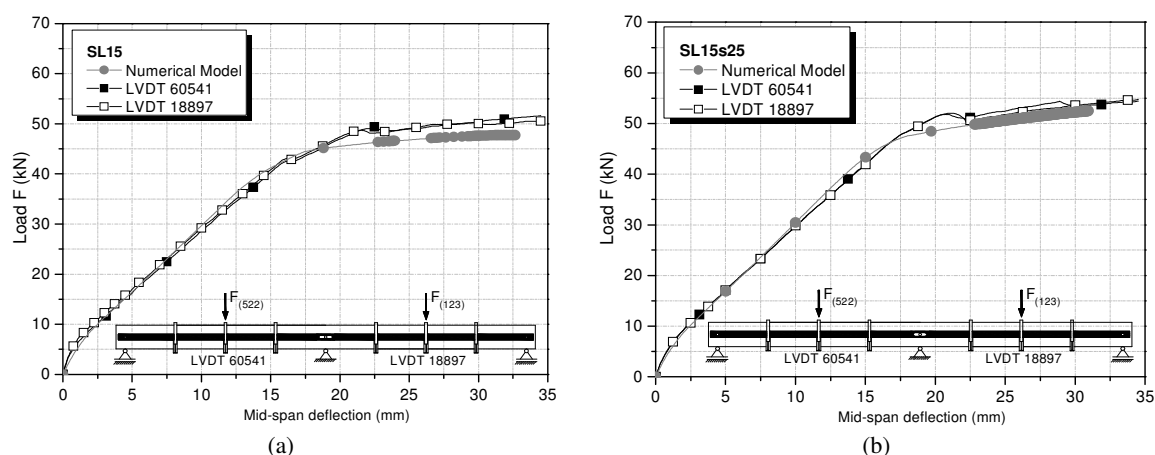

Fig. 2 Load-midspan deflection relationship for the slabs: (a) SL15 and (b) SL15s25.

Tab. 2 Main results of the experimental program (Bonaldo, 2008).

ID	SL15	SL15s25	SL15s50	SL30	SL30s25	SL30s50	SL45	SL45s25	SL45s50
$\Delta \bar{F}_{tar}$	----	25%	50%	----	25%	50%	----	25%	50%
\bar{F}_{max} (kN)	51.36	57.60 (12.15%)	62.36 (21.42%)	49.84	54.87 (10.09%)	58.09 (16.55%)	52.55	54.49 (3.69%)	57.79 (9.97%)
M_{Exp}^- (kN.m)	22.46	33.88 (50.84%)	38.42 (71.06%)	16.24	23.84 (46.80%)	28.85 (77.64%)	13.01	17.25 (35.66%)	22.61 (73.79%)

Note: Values in round brackets express the load carrying capacity or MR increment.

The following remarks can be pointed out: (i) Up to the formation of the plastic hinge at the hogging region, the tensile strains in the laminates are far below their ultimate tensile strain. At concrete crushing (assumed as -3.5%) the maximum tensile strain in the laminates did not exceed 60% of their ultimate tensile strain, and (ii) the force-deflection relationship evidences that, up to the formation of the plastic hinge at the hogging region, the laminates had a marginal contribute for the slabs load carrying capacity. Fig. 3 depicts the relationship between the average applied load and the moment redistribution percentage η for the slab strips series SL15 and SL30. It is visible that, in general, after the cracking load (\bar{F}_{cr}) the moment redistribution decreases up to the formation of the plastic hinge in the hogging region (\bar{F}_y^h), followed by an increase of η up to the formation of the plastic hinge in the sagging regions (\bar{F}_y^s). The decrease of η is due to the decrease of stiffness in the sagging regions due to the crack formation and propagation in these zones. When the plastic hinge is developed at the hogging region, the consequent loss of stiffness forces a migration of moments from the hogging to the sagging regions resulting in an increase of η . Fig. 3 also shows that η decreases with the increase of the percentage of CFRP laminates.

3 Predicting the behavior of strengthened RC slabs

Numerical simulations were performed using a FEM-base program able to simulate the nonlinear behavior of RC slab strips strengthened according to the NSM CFRP technique. The concrete slab was considered as a plane shell formulated under the Reissner-Mindlin theory (Barros and Figueiras, 2001). A detailed description of this model can be found elsewhere (Barros *et al.*, 2008). The predictive performance of this model was assessed by simulating the tested slabs. According to the results (Fig. 2), the implemented numerical model is capable of simulating with good accuracy the main relevant behavioral aspects of this type of structures. Due to space limitation, this paper only deals with the simulations of SL15 series, but the entire numerical program is treated in detail elsewhere (Dalfré and Barros, 2010).

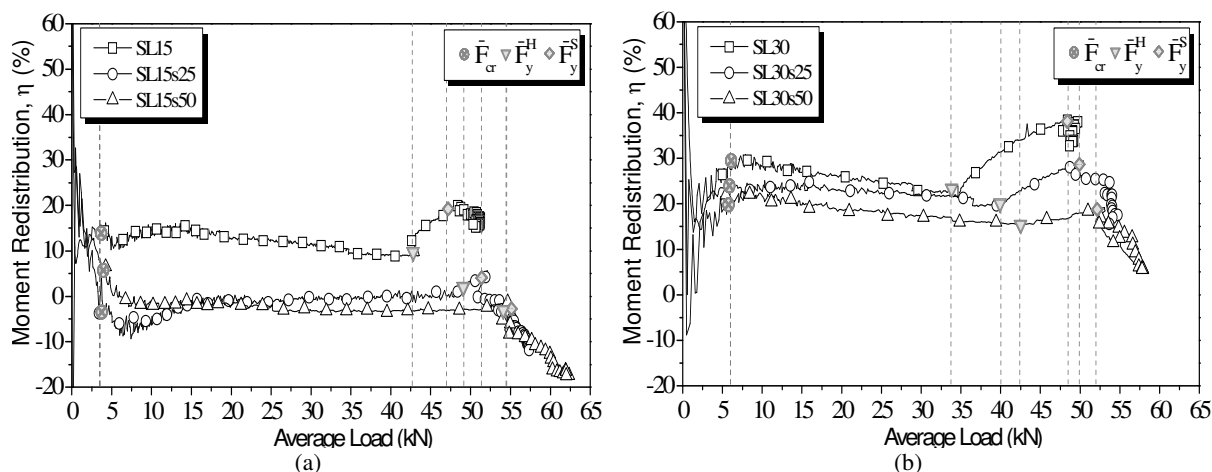

Fig. 3 Moment redistribution, η , for the slab strips series (a) SL15 and (b) SL30.

4 Parametric study

The computer program, which good predictive performance on the simulation of the behavior of the type of structures in analysis was confirmed in the previous chapter, was adopted to execute a parametric study for the evaluation of the influence on the load carrying capacity, and moment redistribution capacity of the following parameters: strengthening configuration and percentage of CFRP laminates.

4.1 Strengthening arrangements and numerical simulations

The arrangement of the longitudinal steel bars, dimensions of the cross sections, support and load conditions are the same adopted in the experimental/numerical program for the reference slab strip of SL15 series. However, distinct strengthening arrangements were applied in the hogging (H) and sagging regions (S), as shown in Fig. 4 and Tab. 3. In the parametric study, the mechanical properties adopted for the concrete strength class (C25/30) were determined following the recommendations of Eurocode 2 and CEB-FIP Model Code 90. The values of the parameters adopted for the constitutive model used to simulate the behavior of the steel bars can be found elsewhere (Bonaldo, 2008). For the numerical simulations, the CFRP laminates of $1.4 \times 20 \text{ mm}^2$ cross sectional area were assumed as an isotropic material with an elasticity modulus of 165 GPa and null value for the Poisson's coefficient, since the consideration of their real anisotropic properties has marginal influence in terms of their contribution for the behavior of NSM strengthened RC slabs.

4.2 Main results

The slab strips can be classified in three different groups due to the position of the adopted strengthening arrangement: (a) hogging region, (b) sagging region and (c) both sagging and hogging regions. The relationship between the load applied in each span (F) and the midspan deflection for the slab strips strengthened in the hogging region (Fig. 4a), sagging region (Fig. 4b) and in both hogging and sagging regions (Fig. 4c) are presented in Fig. 5. The notation adopted to identify the slab strips is $SL_x_y_w_z$, where SL is the slab strip base, x is the moment redistribution percentage, η (15%), y is the concrete strength class (C25/30) and w or z are the NSM CFRP laminates applied in the sagging or hogging regions, respectively. In the evaluation of the following items, the formation of the second hinge (at the loaded section) was assumed as the ultimate failure condition.

In the cases where the NSM CFRP laminates are only applied in the hogging region (H), Fig. 5a, the failure mechanism is governed by yielding of internal reinforcement in the hogging region, followed by the premature formation of the second hinge at the loaded section. In this case, the deflection at the

formation of the plastic hinge in the hogging region and the deflection amplitude between the formation of both plastic hinges have decreased with the increase of the equivalent reinforcement ratio (due to the increase of CFRP percentage). According to the results, no significant increase of load carrying capacity is obtained, which is in agreement to the experimental results obtained by Bonaldo (2008).

In the cases where the NSM CFRP laminates are only applied in the sagging region (S), **Fig. 5b**, the formation of the first hinge occurs for similar deflections. However, the deflection amplitude between the formation of a plastic hinge in sagging and hogging regions has increased with the increase of the equivalent reinforcement ratio. The increase of load carrying capacity is now more pronounced with the percentage of laminates than in the previous cases.

Finally, in the cases where the NSM-CFRP laminates are applied in both regions (H and S), **Fig. 5c**, the amplitude of deflection between the formation of the plastic hinges in the hogging and sagging regions is almost the same for the analyzed cases. The increase of load carrying capacity with the percentage of laminates, ρ_f , is the highest amongst the three analyzed configurations, mainly up to the initiation of the plastic hinge in the hogging region. According to the results obtained by Dalfré and Barros (2010), the flexural strengthening performance of a slab strip strengthened with NSM CFRP in both hogging and sagging regions is limited by the detachment of the concrete cover that includes the laminates or due to the formation of shear crack at the hogging region.

Tab. 3 Strengthening details of the cross sections of the slab strips in the parametric study.

Cross-Section S_1-S_1'	Number of NSM CFRP laminates ⁽¹⁾	$\rho_{s,eq}$ (%)	Cross-Section S_2-S_2'	Number of NSM CFRP laminates ⁽¹⁾	$\rho_{s,eq}$ (%)
$A_s' = 2\phi 12\text{mm}$	0	1.71	$A_s = 5\phi 12\text{mm}$	0	1.60
$A_s = 4\phi 12\text{mm}$	2	1.82	$A_s' = 2\phi 12\text{mm}$	2	1.71
+ $3\phi 8\text{mm}$	4	1.92	+ $1\phi 8\text{mm}$	4	1.82

A_s' - compressive reinforcement, A_s - tensile reinforcement, ⁽¹⁾ of $1.4 \times 20 \text{ mm}^2$ cross section

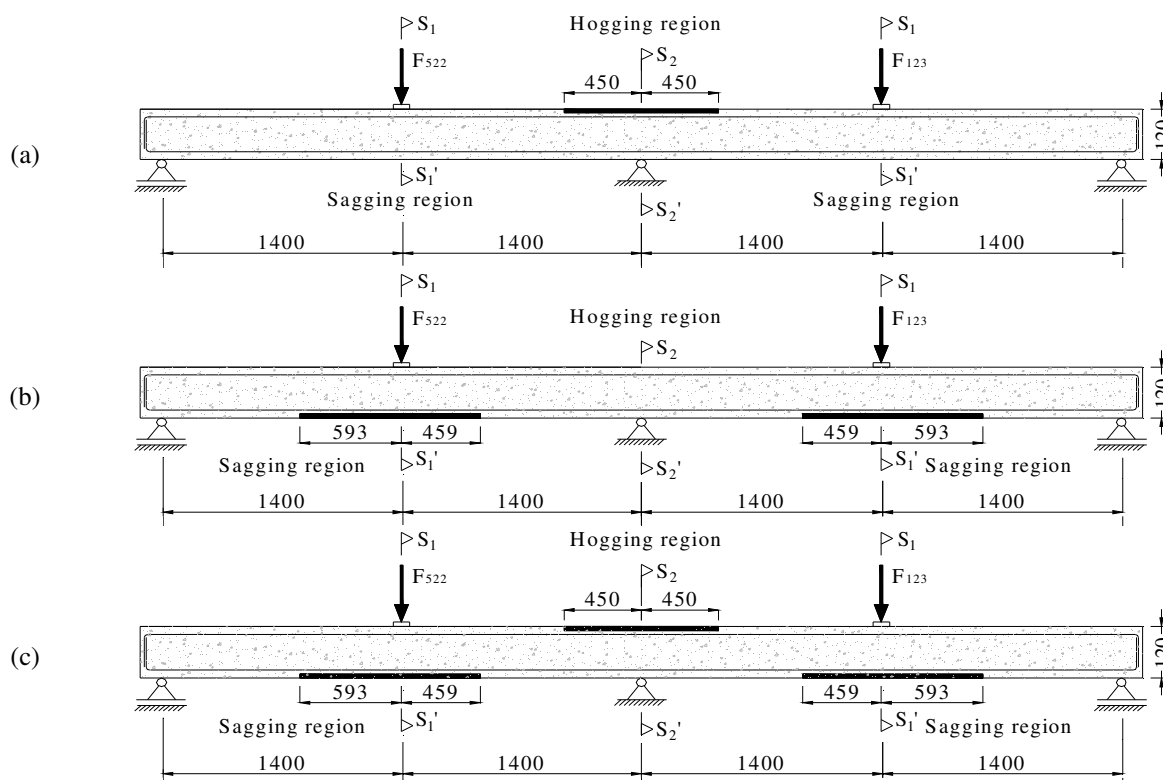

Fig. 4 Strengthening arrangements: NSM CFRP laminates applied in the (a) hogging region, (b) sagging region and (c) sagging and hogging regions.

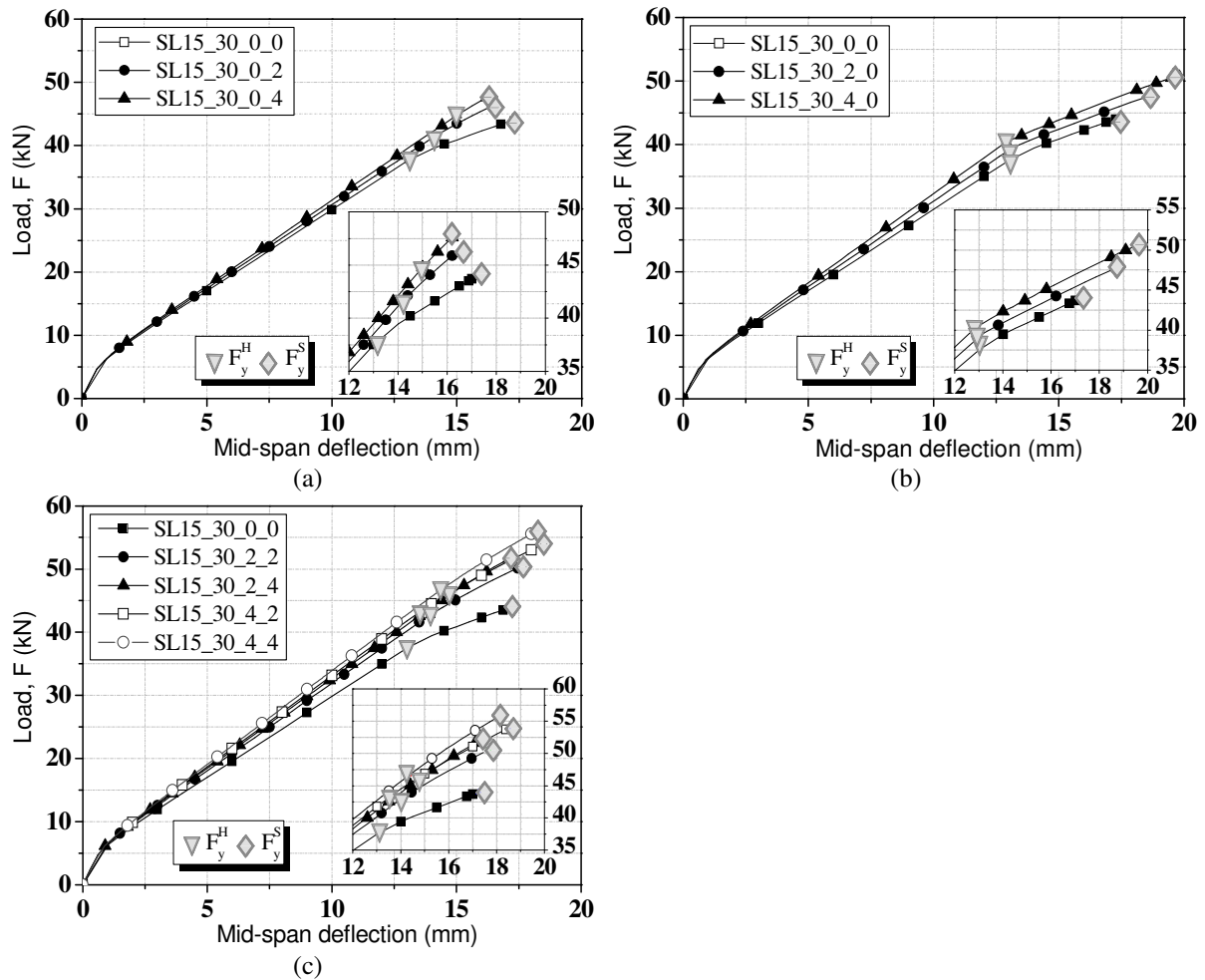

Fig. 5 Force-midspan displacement relationship for the slab strips strengthened in the: a) hogging, b) sagging and c) both hogging and sagging regions.

4.2.1 The load carrying capacity index

The load carrying capacity index (λ) is defined as the ratio between the force obtained when using the strengthening technique, F_{streng} , and the force obtained in the reference slab, F_{ref} , ($\lambda = F_{streng} / F_{ref}$), where F is the force at the initiation of the second plastic hinge. The relationships between λ and $\rho_{s,eq}$ in the hogging ($\rho_{s,eq}^H$) and sagging ($\rho_{s,eq}^S$) regions are represented in **Fig. 6**. The load carrying capacity of the strengthened slabs increases with $\rho_{s,eq}^S$ and $\rho_{s,eq}^H$, but the increase of λ is more pronounced with $\rho_{s,eq}^S$. For the slabs only strengthened in the hogging region, the increase of λ is less than 10%, which is in agreement to the experimental results obtained by Bonaldo (2008).

4.2.2 Moment redistribution analysis

The moment redistribution index (MRI) is defined as the ratio between the η in a strengthened slab, η_{streng} , and in the reference slab, η_{ref} , ($MRI = \eta_{streng} / \eta_{ref}$), where η is the moment redistribution percentage at the formation of the second hinge (in the sagging region).

The relationship between MRI and the equivalent reinforcement ratio is shown in **Fig. 7**. It can be noted that the moment redistribution depends strongly on the strengthening arrangement. In the

slab strips only strengthened in the hogging region η_{streng} is less than η_{ref} . Increasing the percentage of laminates in the sagging region, MRI increases, regardless the $\rho_{s,eq}^H$. For slabs only strengthened in the sagging regions, $MRI > 1.0$, which means that the strengthened slab has higher moment redistribution capacity than its reference slab. However, with the increase of the percentage of laminate in the hogging region, the MRI decreases.

To avoid a decrease in the moment redistribution capacity, CFRP laminates strips should be applied in both sagging and hogging regions, in appropriate percentages. Fig. 8 shows that the moment redistribution index increases with $\rho_{s,eq}^S / \rho_{s,eq}^H$. For $\rho_{s,eq}^S / \rho_{s,eq}^H > 1.13$ the MRI is positive.

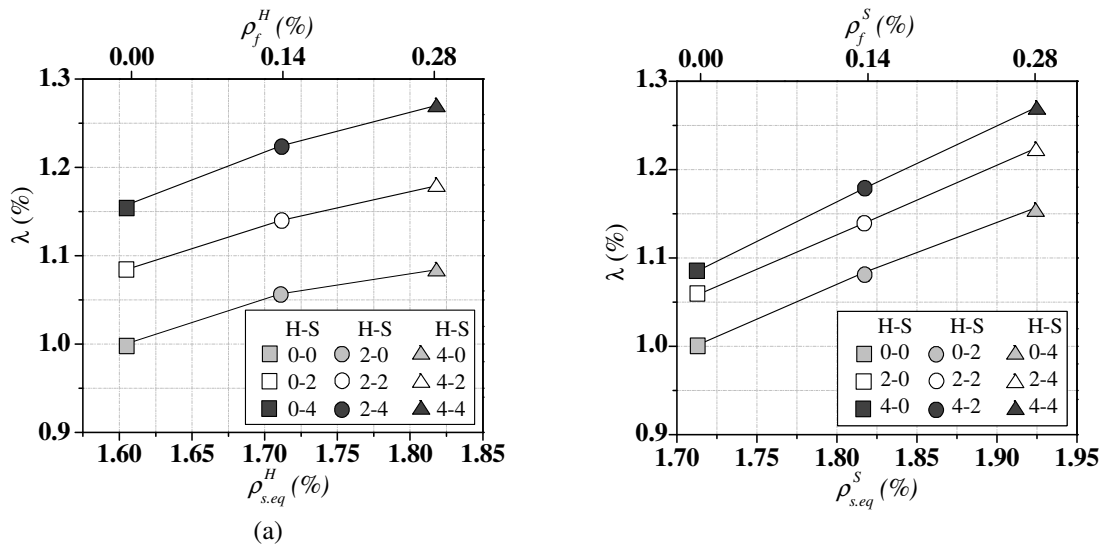

Fig. 6 Relationship between the load carrying capacity index and the equivalent reinforcement ratio in the: a) hogging, and b) sagging regions.

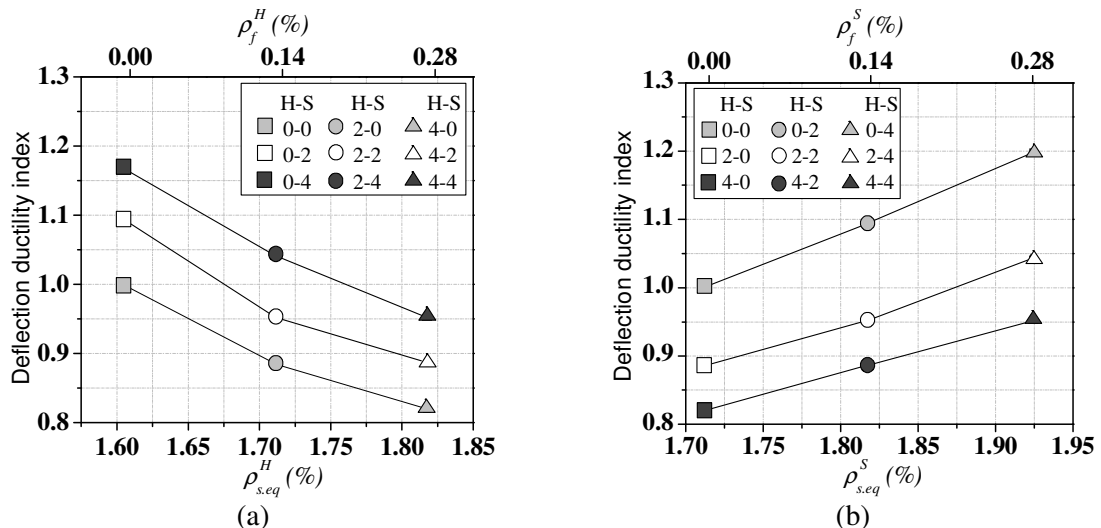

Fig. 7 Relationship between the moment redistribution index and the equivalent reinforcement ratio in the: a) hogging, and b) sagging regions.

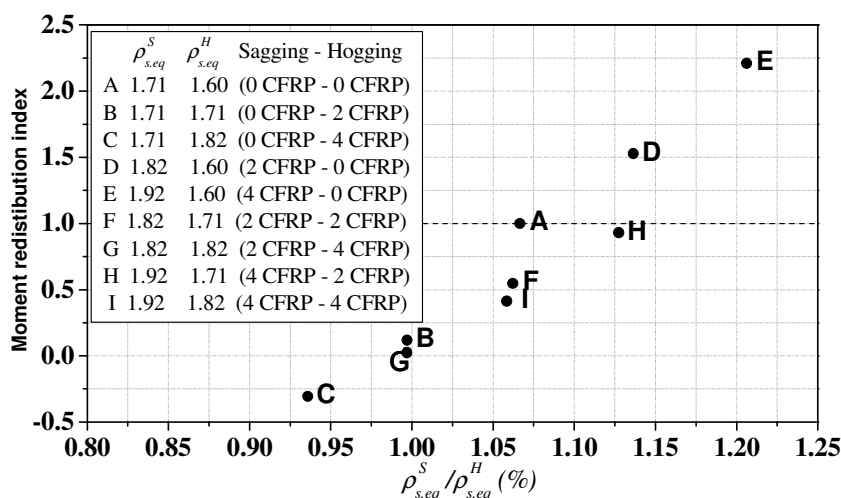

Fig. 8 Relationship between the moment redistribution index and $\rho_{s,eq}^S / \rho_{s,eq}^H$.

5 Conclusions

In this work a parametric study was carried out with a FEM-based computer program to assess the influence of flexural strengthening configuration and amount of CFRP in terms of load carrying and moment redistribution capacities of continuous RC slab strips. From the obtained results it can be pointed out the main following observations:

- (i) The load carrying and the moment redistribution capacities strongly depend on the flexural strengthening arrangement;
- (ii) The load carrying capacity of the strengthened slabs increases with $\rho_{s,eq}^S$ and $\rho_{s,eq}^H$, but the increase is much more pronounced with $\rho_{s,eq}^S$, specially up to the formation of the plastic hinge in the hogging region;
- (iii) The moment redistribution decreases with the increase of $\rho_{s,eq}^H$, and increases with $\rho_{s,eq}^S$.
- (vi) The moment redistribution increases with $\rho_{s,eq}^S / \rho_{s,eq}^H$, and positive values (which means a moment redistribution higher than the one of the corresponding reference slab) are only obtained for $\rho_{s,eq}^S / \rho_{s,eq}^H > 1.13$.

The results evidence that the use of efficient strengthening strategies can preserve an adequate ductility and moment redistribution in statically indeterminate structures, with a considerable increase in the load carrying capacity.

Acknowledgement

The reported study forms a part of the research program “CUTINEMO - Carbon fiber laminates applied according to the near surface mounted technique to increase the flexural resistance to negative moments of continuous reinforced concrete structures” supported by FCT, PTDC/ECM/73099/2006. The authors wish to acknowledge the support also provided by the S&P and Unibetão.

References

- [1] Vasseur, L., Matthys, S. and Taerwe, L., “Debonding mechanisms and moment redistribution of 2-span RC beams externally strengthened with FRP”, 8th International Symposium on Fiber Reinforced Polymer Reinforcement for Concrete Structures - FRPRCS-8, University of Patras, Patras, Greece, 10 pp., July, 2007.
- [2] El-Rafaie, S.A., Ashour, A.F. and Garrity, S.W., “Flexural strengthening of RC continuous beams using CFRP laminates”, Cement and Concrete Composites Journal, 26, 765-775, 2004.

- [3] Ohlers, D.J., Ju, G., Liu, I.S.T. and Seracino, R., "Moment redistribution in continuous plated RC flexural members. Part 1: neutral axis depth approach and tests", *Engineering Structures*, 26(14), 2197-2207, December 2004.
- [4] Aiello, M.A., Valente, L. and Rizzo, A., "Moment Redistribution in continuous reinforced concrete beams strengthened with carbon-fiber-reinforced polymer laminates", *Mechanics of Composite Materials*, 43(5), 667-686, 2007.
- [5] Barros, J.A.O.; Kotynia, R., "Possibilities and challenges of NSM for the flexural strengthening of RC structures", Fourth International Conference on FRP Composites in Civil Engineering (CICE2008), Zurich, Switzerland, 22-24 July, 2008
- [6] Blaschko, M., "Bond behaviour of CFRP strips glued into slits", *Proceedings of the 6th International Symposium on Fiber Reinforced Polymer Reinforcement for Concrete Structures* (Tan KH, ed.), FRPRCS6, Singapore, World Scientific, 2003.
- [7] Barros, J.A.O., and Fortes, A.S., "Flexural strengthening of concrete beams with CFRP laminates bonded into slits", *Cement and Concrete Composites Journal*, 27(4), 471-480, April 2005.
- [8] Barros, J.A.O., Dias, S.J.E., Lima, J.L.T., "Efficacy of CFRP-based techniques for the flexural and shear strengthening of concrete beams", *Cement and Concrete Composites Journal*, 29(3), 203-217, March 2007.
- [9] Liu, I.S.T., "Intermediate crack debonding of plated reinforced concrete beams", PhD Thesis, School of Civil and Environmental Engineering, The University of Adelaide, Adelaide, Australia, November 2005.
- [10] Liu, I.S.T, Oehlers, D.J. and Seracino, R.. "Tests on the ductility of reinforced concrete beams retrofitted with FRP and steel near surface mounted plates." *ASCE Journal of Composites for Construction*, March/April, Vol.10, No.2, pp106-114, 2006.
- [11] Bonaldo, E. Composite materials and discrete steel fibres for the strengthening of thin concrete structures - NSM strengthening technique for double span continuous RC slabs, , PhD Thesis, Department of Civil Engineering, University of Minho, Portugal, 2008.
- [12] ACI Committee 318, "Building code requirements for structural concrete and Commentary (ACI 318-04)", Reported by committee 318, American Concrete Institute, Detroit, 351 pp., 2004.
- [13] CEB-FIP Model Code 1990. "Design Code". Thomas Telford, Lausanne, Switzerland, 1993.
- [14] Barros, J.A.O. and Figueiras, J.A. "Nonlinear analysis of steel fibre reinforced concrete slabs on grade", *Computers & Structures Journal*, Vol. 79(1), pp. 97-106, 2001.
- [15] Barros, J.A.O., Dalfré, G.M. and Dias, J.P. "Numerical Simulation of Continuous RC Slabs Strengthened using NSM Technique", *Proceedings of 2nd International Conference on Concrete Repair, Rehabilitation and Retrofitting*, Cape Town, South Africa, November 2008.
- [16] Dalfré, G.M.; Barros, J.A.O., "Flexural strengthening of RC continuous slab strips using NSM CFRP laminates", Accepted to be published in the *Journal Advances in Structural Engineering*, 2010.
- [17] EN 1992-1-1. "Eurocode 2: Design of Concrete Structures-Part 1-1: General Rules and Rules for Buildings." CEN, Brussels, 2010.

Matteo Breveglieri Phd student

✉ University of Ferrara
Engineering Department
Via Saragat 1
44122 Ferrara Italy
☎ +390532974943
@ matteo.breviglieri@unife.it

Prof. Joaquim A. O. Barros

✉ ISISE, University of Minho
Department of Civil Engineering
Campus of Azurém
Portugal
☎ +351 253 510 217
@ barros@civil.uminho.pt

Gláucia M. Dalfré PhD Student

✉ ISISE, University of Minho
Department of Civil Engineering
Campus of Azurém
Portugal
☎ +351 253 510 217
@ gmdalfré@civil.uminho.pt

Prof. Alessandra Aprile

✉ University of Ferrara
Engineering Department
Via Saragat 1
44122 Ferrara Italy
☎ +390532974943
@ alessandra.aprile@unife.it
