

# Textile moisture sensor matrix for monitoring of disabled and bed-rest patients

Tiago Pereira, Pedro Silva  
 Dep. Industrial Electronics  
 University of Minho  
 Guimarães, Portugal

Helder Carvalho, Miguel Carvalho  
 Dep. Textile Engineering  
 University of Minho  
 Guimarães, Portugal

**Abstract**—This paper presents the development of a moisture sensor matrix based on textile materials provided with conductive yarns. The measurement principle is based on the measurement of electrical resistance of the textile.

The main purpose of this work is to support research on the prevention of pressure ulcers in people committed to bed rest or using wheelchairs. In the first stage of development, the project is studying the relation between physical parameters, exposure time and the levels of discomfort and pain experienced by the patients. In a later stage, the underlying measurement and evaluation principles will be used to develop single sensors or sensor matrixes to be connected to active patient monitoring systems able to warn in situations of excess of moisture and/or pressure (produced by sweat, open wounds, incontinence, etc.).

**Keywords**- textile sensors, e-textiles, moisture sensors, people with special needs

## I. INTRODUCTION

Pressure ulcers, also called pressure sores, are areas of damage to the skin and underlying tissue. Pressure ulcers are frequently found in elderly people and in patients with reduced mobility and/or reduced or total lack of skin sensation. They are also a concern during surgical interventions in which patients are kept under sedatives for long periods of time.

In a study performed between 1999 and 2002, pressure ulcers have been associated to the following main risk factors: increasing age, male gender, dry skin, urinary and faecal incontinence, difficulty turning in bed, nursing home residence prior to admission, recent hospitalisation, and poor nutritional status [1]. The physical parameters most influencing the development of pressure ulcers are pressure, friction and moisture at the skin interface.

In this project, the development of a cushion or mattress integrating pressure, temperature and moisture is being undertaken. The cushion should be an all-textile product, with enough flexibility and conformability to provide by itself an ergonomic and comfortable support surface for the patient. The development of pressure sensing is achieved by capacitive sensing using fabrics woven with conductive yarns, and is described elsewhere [2]. In this paper, the development of moisture sensing is described. The sensor should be simple, inexpensive and unobtrusive. At this stage, measurement accuracy is not a big concern, an approximate indication of moisture content and distribution is sufficient.

## II. MOISTURE SENSING IN TEXTILES

There are several authors proposing solutions for moisture sensing, although slightly different from the current application.

Reference [3] proposes the use of optical fibres to measure the onset and duration of human sweating events.

The integration of moisture, temperature and pressure sensors into blankets and bed covers is proposed in [4] and [5]. The moisture sensor, used to monitor sweating and incontinence, is based on an “interdigital structure”, woven or embroidered onto an area of the blanket.

Similar incontinence (“enuresis”) sensors, although printed on plastic sheets, are offered commercially. They are placed between the bed sheets and the mattress. Their indication is digital, meaning that it will signal the appearance of moisture, but not its amount.

In the work herein presented, besides the detection of presence of moisture, it is necessary to represent the quantity and distribution of moisture over an area of the bed.

## III. PROPOSED SOLUTION

### A. Sensor

The solution proposed in this research work is displayed in figure.1

The sensor is based on two layers of striped fabric which has been woven alternating cotton yarn with electrical

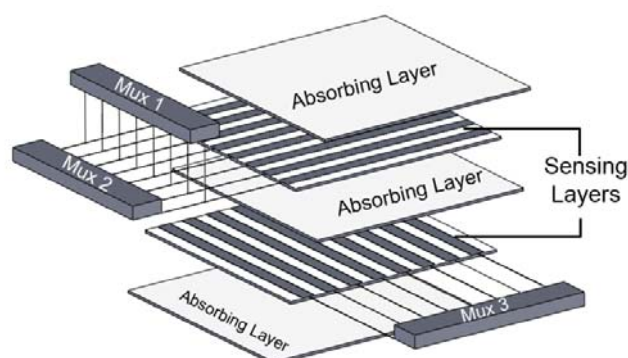

Fig. 1. Sensor set-up and connection scheme

conductive yarns and wires. The prototype sensor used in this paper has been produced with 7 conductive stripes on each layer.

Several alternatives can be chosen to use as conductive yarns. In this work, we have used Bekintex 50/2 conductive yarn and 50 $\mu$ m stainless steel monofilament wire, both from the belgian manufacturer Bekaert. Bekintex 50/2 is a 2-ply 80%/20% polyester/stainless steel staple yarn that presents reasonable electric conductivity. The stripes woven with this yarn are thus electrically conductive, but they preserve their textile touch.

The two layers are turned 90 degrees one in respect to the other, thus forming a matrix.

The upper, middle and lower layer are cotton knitted fabrics, assuring both a comfortable interface to the user's skin as well as good liquid absorption.

Figure 2 shows a photograph of the set-up used. One of the most troublesome issues to solve is the electrical connection. Mechanical clamping was used to connect the textile "stripes" to electrical wires, but it would be possibly easier to weave the sensor with fine copper wire or stainless steel wire with a coating allowing soldering.

### B. Signal conditioning and acquisition

Originally, each sensing layer was connected to one multiplexer. By selecting one line in each sensing layer, it was thus possible to get a measure of the amount of moisture near the area where the selected top stripe crosses the selected bottom stripe.

However, this measurement scheme only allows the detection of moisture when it has been absorbed into the middle absorbing layer. To enable an immediate detection of a sweating or incontinence event, the upper sensing layer has been connected to two multiplexers, making it possible to measure the conductivity between two stripes of the upper sensing layer, as shown in fig. 3.

Signal conditioning is based on an inverting amplifier whose feedback resistance is the conductive path selected by the multiplexers on the textiles. This makes the output signal proportional to the resistance of the fabric's path. The amplifier is saturated when the sensor is dry ( $R_{tex} \rightarrow \infty$ ). By lowering the input tension  $V_{ref}$ , it is thus possible to adjust the system's sensitivity to moisture. The lower  $V_{ref}$ , the smaller is the decrease in  $R_{tex}$  necessary to draw the amplifier from



Fig. 2. Photograph of the sensor

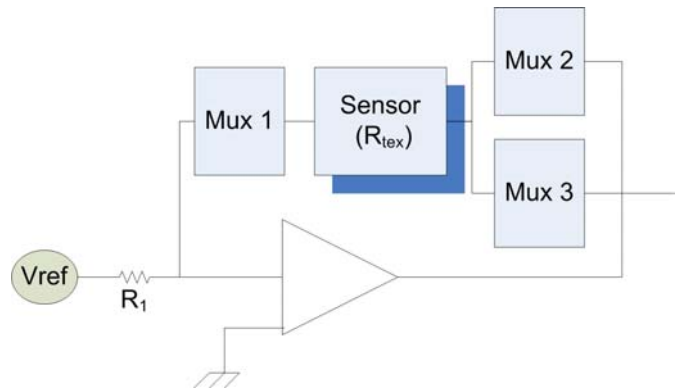

Fig. 3.: Signal conditioning multiplexing scheme

saturation.

The output signal was then connected to a National Instruments NI-USB 6259 Multifunction data acquisition board plugged to a PC. The analogue output of the acquisition board was used to provide a configurable reference voltage.

### C. Software

A software application was developed in National Instruments Labview (figure 4). The software scans the sensor matrix continuously, displays the values in a coloured "intensity graph" and logs the values to a file for later analysis. The display consists of two graphs, one displaying the values of voltage obtained by scanning the upper sensing layer (conductivity between stripes in pairs, displayed as vertical lines) and the other displaying the values between the upper and lower sensing layers.

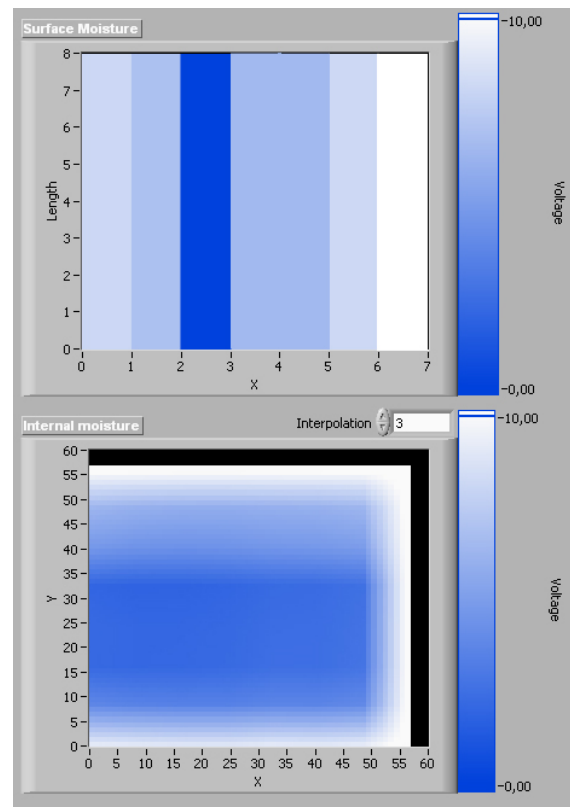

Fig. 4. Surface moisture (measurement between vertical lines, upper graph) and internal moisture matrix (moisture between upper and lower sensing layers, linearly interpolated display, lower graph).

## IV. RESULTS

### A. Preliminary observations

When the system was tested the first time it became evident that the resistance between the two sensing layers is not only dependent on the moisture content on the fabrics. The compression force between the layers also has an important influence on the measured resistance. Even if a final version of the sensors is constructed to maintain the layers closely together (by gluing, fusing or sewing the individual layers) an influence of the pressure is always to be expected.

However, this fact does not invalidate the solution in the current context. On one hand, the sensor will be used to monitor bed-rest people, to prevent pressure-ulcers. The fact that pressure boosts the indication of moisture gives a measure of the risk to which the patient is exposed, combining the pressure/moisture factors. On the other hand, since the system will be used in combination with a pressure-measurement system, it may be possible to correct the readings. Finally, the system is intended to be a simple system with a qualitative rather than a quantitative analysis, adding just some more information to the existing incontinence detectors.

### B. Experiment

To test the system and illustrate its operation, a simple experiment was designed. A sensor with the sensing layers woven using 50 $\mu$ m stainless steel wire was used.

First, a NaCl solution simulating sweat was prepared. According to [6], sweat conductivity on a group of healthy children was measured between 2 and 14  $\mu$ S/cm. The average value of 8  $\mu$ S/cm was taken and the solution was prepared to have this conductivity.

The acquisition system was turned on and the centre of the sensor was wetted with the solution through a circular-shaped mask of about 2 cm diameter. The sensor was then covered with a 15x15 cm tile, providing a smooth surface to apply even pressure throughout the sensor's surface. Above the tile,

a 5kg mass was placed.

Acquisition was performed for about 4,5 hours. Then, the tile was removed and the inner absorbing layer was taken out, dried and put back in place with the tile and mass on it.

Figure 4 shows the display after about 8 minutes.

It was quite interesting to observe how moisture started spreading in the x-direction and only then did it spread in the y-direction. The x-direction is the direction of the stripes of the upper sensing layer. Considering that this layer has stripes woven out of yarn containing stainless steel, with less moisture absorption than cotton, this kind of behaviour was expected. Moisture started spreading through the non-conductive stripes on the upper sensing layer. When it reached the inner layer, the circular shape of wet fabric had turned into a more rectangular shape. Only after a while did the moisture spread more significantly in y-direction, through the absorbing fabric layers.

Figures 5 and 6 show the evolution of the measured voltage in surface sensor 3 and matrix sensor (3,3).

There are several events in these graphs whose effect is worth analysing.

First of all, the internal moisture sensor only detects the applied liquid with a significant delay, since the liquid has to be absorbed by two layers of fabric until it reaches the central absorbing layer. When pressure is released from the sensor (event "mass lifted"), conductivity through the central layer ceases to exist. This is the case of the currently used sensor, in which the layers have been simply stacked on each other without anything holding them together. However, as previously discussed, even if they were held together, a change in pressure would have an effect on the output. The surface sensor's reading, though, is not significantly affected.

Figure 6 shows the final phase of the measurement and the effect of drying the inner layer. When the inner layer is inserted in a dry state, it starts absorbing the liquid in the neighbouring layers, changing from a state of non-conductivity to a new output value. At the same time, it is

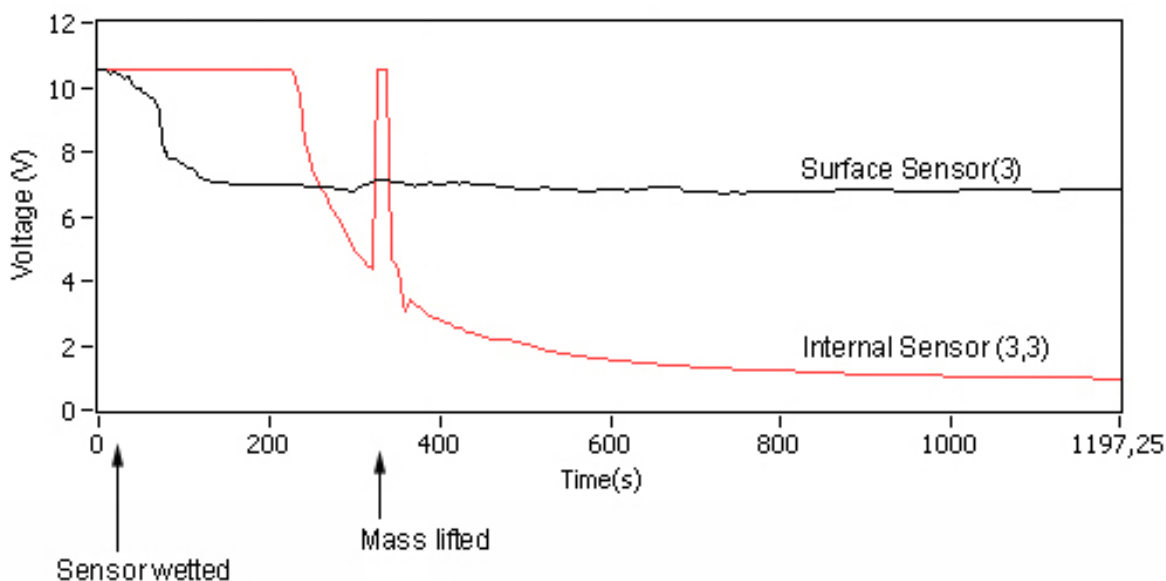

Fig. 5. Log of internal sensor (3,3) and surface sensor 3 in the initial phase

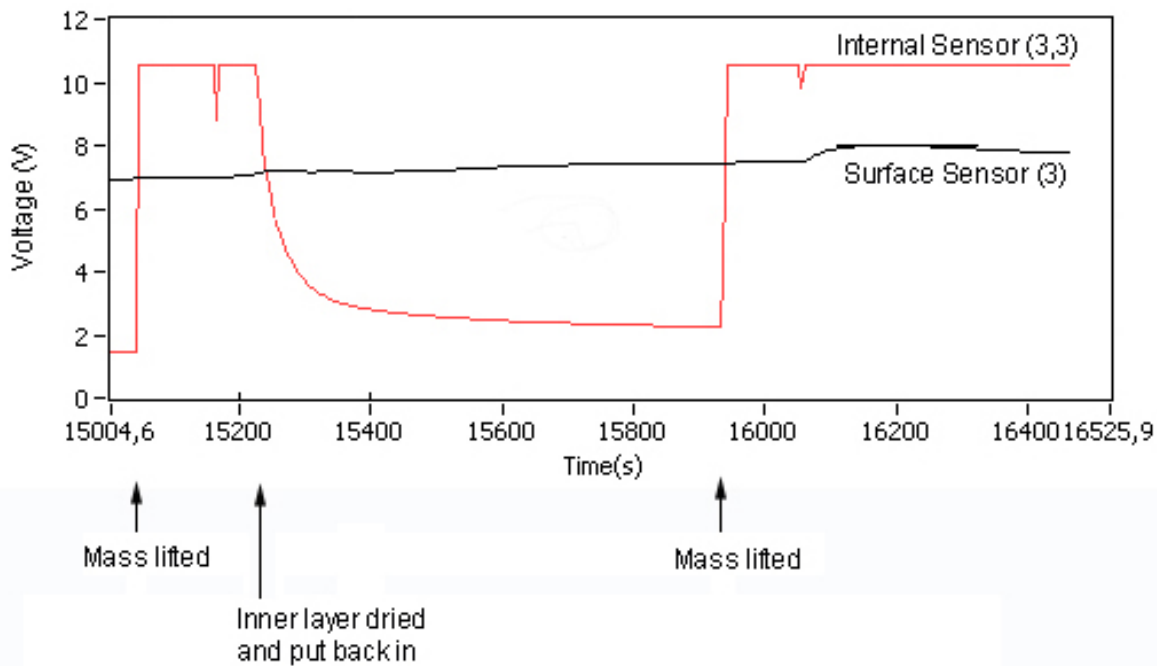

Fig. 6. Log of internal sensor (3,3) and surface sensor 3 in the final phase

possible to see that the surface sensor's value is increasing, meaning – as expected - that it is becoming dryer.

#### V. CONCLUSIONS AND FUTURE WORK

In this work, a completely textile moisture sensor matrix of simple design is being developed. A first evaluation of the sensor shows that it gives a good indication of moisture content and its spatial distribution. The sensor has the potential to be produced inexpensively and can be made of materials by themselves friendly to the patient's skin. It may even work itself as an absorbing element in the treatment and prevention of pressure ulcers.

This first approach has allowed us to identify some aspects to optimise in future work

The first is to maximize the therapeutic value of the element itself, by improving the comfort of the sensor in contact with the skin, including anti-bacterial products, maximising the absorption capacity of the materials used, etc.

The second is to determine the measurement accuracy of this sensor matrix, especially considering the dependence of the output values with the compression force applied to the sensor. This will depend on the construction of the sensor and the properties of the materials used. The use of the information provided by a pressure sensor to correct the herein measured values is also a possibility for further improvement.

Finally it is necessary to determine the usefulness of the sensor in an actual clinical environment. This test will contribute to a great extent in the definition of the final sensor configuration: Size, resolution, required accuracy, etc.

In any case, the results herein reported clearly show that an all-textile, comfortable incontinence detector can be readily produced with the proposed solution.

#### ACKNOWLEDGMENTS

The authors wish to thank FCT, which is funding this research through project PTDC/SAU-BEB/68678/2006.

Additional thanks to Eng. Joaquim Jorge Peixoto, technician of our Textile Process Lab, for his enormous support and patience in weaving "strange" materials.

#### REFERENCES

- [1] Mona Baumgarten, David J. Margolis, A. Russell Localio, Sarah H. Kagan, Robert A. Lowe, Bruce Kinosian, John H. Holmes, Stephanie B. Abbuhl, William Kavesh and Althea Ruffin, "Pressure Ulcers Among Elderly Patients Early in the Hospital Stay", *The Journals of Gerontology Series A: Biological Sciences and Medical Sciences* 61:749-754, The Gerontological Society of America, 2006
- [2] J.G. Rocha, H. Carvalho, F.M. Duarte, M. A. F. Carvalho, V.M. Moreira, "System Providing Discomfort Monitoring for People in Wheelchairs", *Proceedings of the IEEE International Symposium on Industrial Electronics*, pp 961-966, Cambridge, UK, 2008
- [3] J. Vaughan, P. J. Scully. Polymer optical fibres (POF) as sweat sensors. *Photon 06: Optics and Photonics 2006*. IOP Publishing: 2006
- [4] C. Rotsch, D. Schwabe, A. Neudeck, W. Scheibner, H. Oschatz, D. Zschenderlein, U. Möhring, Sibylle Hanus, "Technical Textiles for Sanitation and Medicine from the TITV", *dt.-franz. Workshop "Technische Textilien"*, October 2007, Berlin, Powerpoint presentation, 2007
- [5] Sebastian Rumpf, "Patient monitoring system based on textile sensor technology", *Innovationsforum Heidelberg*, April 2008, Powerpoint Presentation, 2008
- [6] Truman S. Licht, Milton Stern, and Harry Shwachman, "Measurement of the Electrical conductivity of Sweat", *Clinical Chemistry*, Vol 3, No. 1, pp 37-48, 1957