

Optimized robot strategy, ball filters and new referee whistle hardware filter

Fernando Ribeiro, Nino Pereira, João Silva, Marco Ferreira, Tomé Silva

Grupo de Automação e Robótica, Departamento de Electrónica Industrial,
Universidade do Minho, Campus de Azurém, 4800 Guimarães, Portugal
fernando@dei.uminho.pt, ninopereira@sarobotica.pt, nrgizer_eei@hotmail.com,
marcofff@gmail.com, tomesilva@sapo.pt

Abstract. This paper briefly describes the main changes on the Minho Team robots since the last RoboCup edition. Work has been carried out on the robots in order to constantly improve their capabilities, based on the experience from previous participations. The main topics to deal in this paper are related with the optimization of movement on the field and also game strategy software, a ball filter recently implemented on the robots in order to follow only the correct ball. Also on this paper a description of the whole software implementation is made by describing the main Algorithm. A new referee whistle hardware filter has been developed in the last year and is here described its electronics.

1. Introduction

Minho Team has been participating on RoboCup for a long time, improving their robots year after year and this year is no exception. The last generation of these robots was started in 2003 [1]. The robots were completely built in the University of Minho Robotics Laboratory (mechanics, electronics and software) and were first drawn in CAD software in order to test if all components would fit physically. Each robot consists of a physical bottom layer where 3 omnidirectional wheels are used to driving and steering the robot, then comes a second layer where all the electronics that control the robot are placed and also the double kicker (horizontal and upwards). Then comes on the third layer the place for the computer and wireless network board, and on the top of the robot is the vision head. Figure 1 show the robot drawn in the CAD software.



Fig. 1. CAD drawing of the new robot

The robots have recently been tested on local tournaments and on Minho Laboratory, and the tests have proven that the hardware is stable.

On this paper first a new robot game strategy is explained; then on section 3 a recently implemented ball filter is described. The rules are moving towards allowing the robots to accept a start or stop from a referee's whistle, and therefore this team has developed a referee whistle hardware filter. On Section 4 this hardware solution is shown and experimental tests have proven that it works fine.

2. Optimized robot strategy

2.1 Introduction

This team used the same software on all robot but they react according to their location on the field. One the behaviours consists of a defender and it is basically the last protection to own goal before the goal keeper. That robot should always oppose the ball or in other words it should always be between the own goal and the ball. In case the ball is near him it automatically becomes an attacker and other robot will replace this one with the defence behaviour.

The new positioning strategy created and adopted for this behaviour is described below.

2.2 Calculating robot positioning for defence

The new strategy consists on the calculus of the robot angle between the team goal and a location between the virtual line the ball makes with the team goal centre (see Fig.2). That is the choice the defender robot makes when it sees the ball. Should it not see the ball the choice is similar to the first positioning but it is made taking the adversary team goal has reference instead of the ball (see Fig.3).

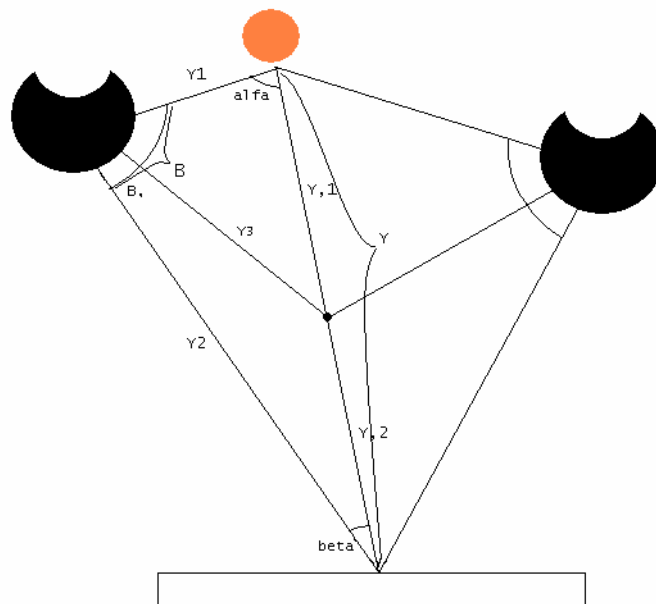

Fig.2 – Robot positioning on defensive strategy (with the ball)

Having the robot the following initial values: Y_1 , Y_2 , B , the next step is to calculate the direction to the location chosen. Given by:

$$Y = \sqrt{Y_2^2 + Y_1^2 - 2Y_2Y_1x \cos(B)}$$

$$beta = \arccos \frac{-Y_1^2 + Y^2 + Y_2^2}{2Y_2Y_1x}$$

$$alfa = \Pi - beta - B$$

$$Y_3 = \sqrt{(Y - Y_1)^2 + Y_2^2 - 2x(Y - Y_1)Y_2 \cos(alfa)}$$

$$B, = \arcsin(\sin(beta)x \frac{Y}{Y_3})$$

- If the robot is on the left side of the line between the ball and the centre of the team goal, then the direction is given by ((team goal angle)- B)
- If the robot is on the right side of the line between the ball and the centre of the team goal, then the direction is given by ((team goal angle)+ B)

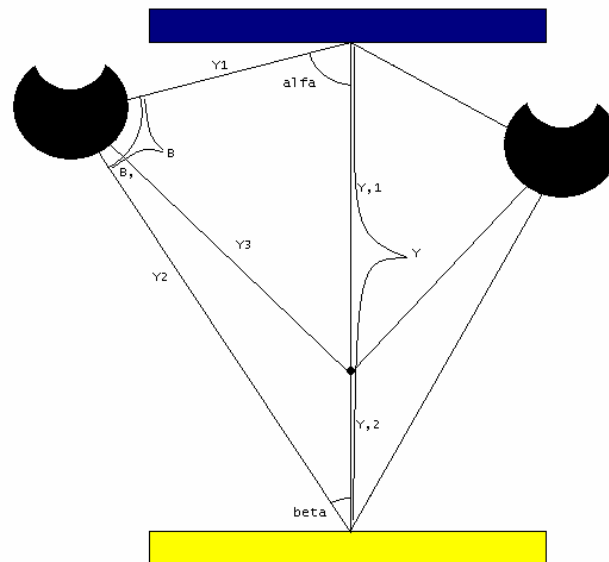

Fig.3 - Robot positioning with defensive strategy (without the ball)

The robot makes the same trigonometric calculus used with the ball as it was explained before.

3. Ball filter

3.1 Introduction

A new ball filter has been implemented to sort out some problems created by image interference. One of the problems is the noise or interferences with the game from outside of the field. The main problems are balls on other fields (when the fields are next to each other), losing grip of the ball for a long time without reason for that, clothing with a similar colour to the ball, intermittent viewing due to long distances to the ball, and many other problems. Since that losing the ball location can be reflected on a bad behaviour by the robots, it is of extreme importance to maintain its positions always known. Even when the ball is not seen it position can be virtually calculated and maintained stable. The filter has the function to calculate the balls position on the field, and to determine the one that has the shortest distance with the older ball from the previous frame.

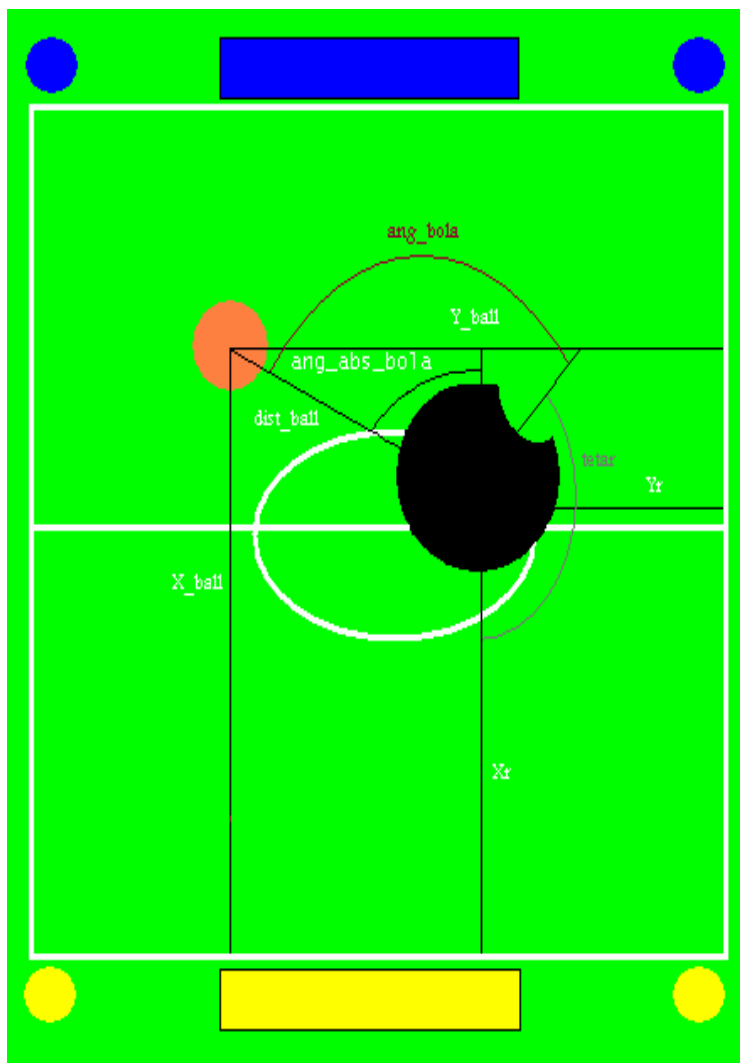

Fig. 4 – Ball position on the pitch

3.2 Solution Description

Figure 4 shows a virtual field where it can be seen the robot in black. Having the robot the following initial values Y_r , X_r , $tetar$, $dist_ball$, ang_bola :

Where:

X_r , Y_r : are the coordinates of the robot on the field

$Tetar$: is the direction the robot is heading to

$Dist_bola$: is the distance from the robot to the ball

Ang_bola : is the angle the ball has in relation to the robot centre line

The way to calculate the ball coordinates on the field: Y_ball and X_ball is:

$$ang_abs_bola = 90 - ((ang_bola) + (-tetar + 360 - 270))$$

$$X_ball = X_r + dist_ball \times \cos(ang_abs_bola)$$

$$Y_ball = Y_r + dist_ball \times \sin(ang_abs_bola)$$

After the robot knows the ball position in relation to the game field, it verifies if the coordinates are inside the pitch. The robot makes this type of calculus for all the balls he detects on the images, so it will see which one is closest to the older ball from the previous frame. This reduces the amount of faked balls.

4. Referee whistle hardware filter

4.1 Introduction

Still many problems occur related with the wireless network, making teams claiming that the robots did not receive the start/stop command. The referee whistle can be used and will be used to instruct robots for at least start/stop the game. Sound should reduce the interference problems. Minho team has been developing a referee whistle hardware filter to be used by the robots so that can they perceive the game start/stop without using the not always reliable wireless network. This kind of solution can bring advantages to the team.

4.2 Hardware description

An electronic board was created and is here described. The electronic circuit starts with a microphone to capture the sound from the surrounding environment. Then, one first Ampop is used just to amplify the signal received from the microphone so it has a reasonable amplitude to be work on. A second Ampop on the top compares the signal to 0, so that when the wave from the microphone passes that threshold reference the Ampop delivers to its output a square wave depending if the input is bigger than the threshold reference ($V_{out}=V_{cc}$) or if it is lower than the reference ($V_{out}=V_{ss}$). Then,

transistors transform the square wave delivered from the Ampop into a digital signal. The first transistor sends 5V pulses when the wave is positive and the second transistor does the same only when the wave is negative. The next step is a Band Pass Filter which has the capability to be configured by a microprocessor. It uses switched capacitors that being switched at a desired frequency can be used as an adjustable resistance, and this can create an adjustable filter. When the filter is configured to the desired frequency, only some frequencies can be detected at its output. The third Ampop on the circuit does the same as the second one with the difference that this one only gives de digital signal for the positive part of the wave filtered. Figure 5 shows the electronic circuit which has already been implemented and tested with success.

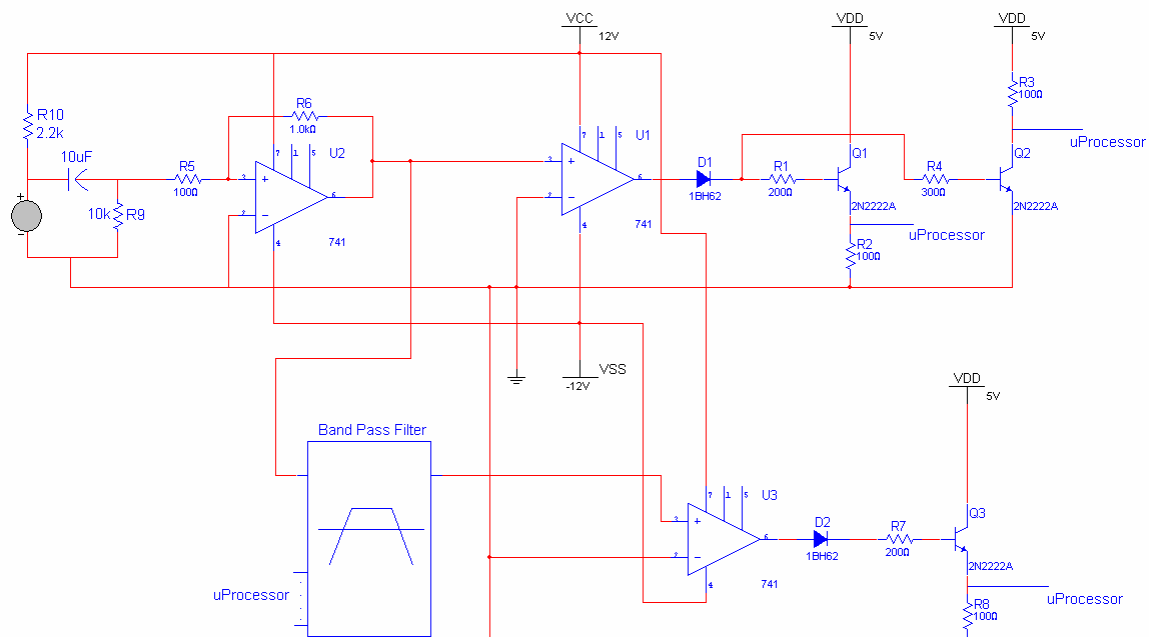

Fig. 5 – Hardware circuit for Filter

Following is pictured and described the algorithm (Figure 6).

The microprocessor waits until the wave is positive to start counting the time it stays positive. Once the wave goes negative the microprocessor saves the frequency acquired from the signal and adjusts the switch capacitors filter so it can filter all the noise (this allows to take into consideration only the referee whistle). The microprocessor waits until there is a whistle from the referee, and when that occurs it will alert the PC so that it can take the adequate measures in the game and then it returns to the same state where it listens to the whistle again.

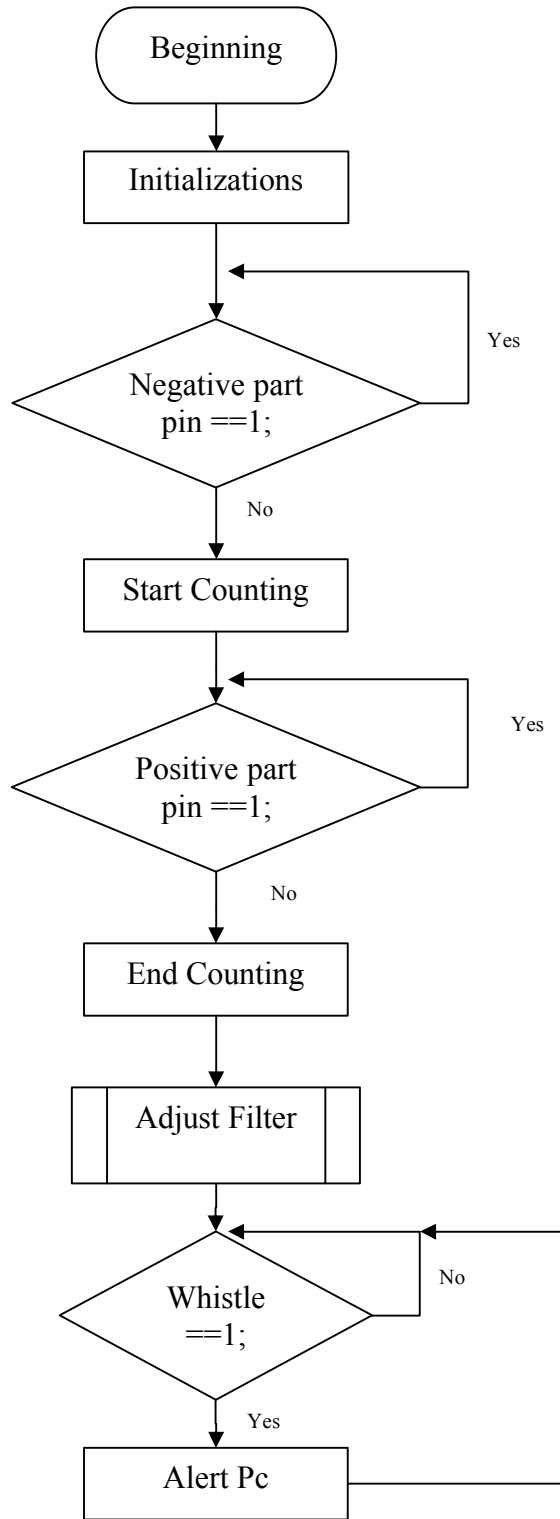

Fig. 6 – Microprocessor algorithm for filter

5 Conclusions

It is important to point out that this work carried out for the last few years is not just a research project, but an engineering and educational project. The main objectives are: a) to pursue research in electronics, computer vision and control, b) to teach the students a practical case of a complex mechatronics system (where they have to plan solutions and sort out problems related with mechanics, electronics and software engineering), and also to make the students build such complex robots to prove in practice what they study in theory. If the result is successful it means they will be good engineers. The topic of football serves as an argument to involve students more easily in their work, despite the solutions having to be achieved successfully.

Despite the success of the last few years, this team continues to evolve and to improve their robots. This year, the vision system has been improved, a ball filter has been implemented which helps reducing the error decision taken regarding the ball position. It has proven to be effective, making the robot start avoiding image noise and maintain the real entities has it own entities. Finally, a referee whistle hardware filter has been created in order to reduce the wireless network problems that occur sometimes. It has not been tested in tournaments yet but the expectations are good, just for the fact that the robots can respond even faster to the game changes made by the referee.

Acknowledgements

The team would like to thank the Algoritmi Research Centre, Department of Industrial Electronics, School of Engineering and University of Minho for all support. Also a special thanks to A Industrial, Lda. who helped us with mechanics parts.

References

¹ Fernando Ribeiro, Paulo Braga, Jorge Monteiro, Ivo Moutinho, Pedro Silva, Vítor Silva, “New improvements of MINHO Team for RoboCup Middle Size League in 2003”, Robocup'2003 – Team Description Paper, Julho 2003, Pádua, Itália.