

Technical improvement of housing envelopes in Portugal

L. Bragança

University of Minho, Guimarães, Portugal

M. Almeida

University of Minho, Guimarães, Portugal

R. Mateus

University of Minho, Guimarães, Portugal

ABSTRACT: The main problems in multi-storey building envelopes in Portugal are the low thermal insulation and low airborne sound insulation. These problems are more relevant in buildings built before the publication of the first thermal code. The envelopes, mainly the façades of buildings built in that period, do not fulfill the actual users comfort requirements and construction codes. This way, it is necessary to find the most appropriate technical solutions to refurbish those façades. One of most used technical solutions is the ventilated façade. In this paper the impacts of this technical solution in standard envelopes are going to be discussed. The impacts will be assessed looking at technical, functional, social, economical and environmental proprieties.

1 INTRODUCTION

1.1 *Standard envelopes in Portugal*

Since 1950 the building technology in Portugal is based on a steel reinforced concrete beams and pillars system. In spite of existing few exceptions to this general rule, it can be assumed that 99% of the housing buildings envelopes built after the early 60's has the following pattern:

- Structure: it is composed of steel reinforced concrete frames of columns and beams.
- Exterior walls: the non load-bearing hollow brick walls emerged in the 60's and it continues to be the most used solution. Actually, the most used technique is the hollow brick cavity wall. The insulation layer on the cavity of the walls is standard on buildings built from the late 80's (Fig. 1);
- Fenestration: until the 70's the windows frames were in wood. Since the 70's most of the windows frames are made of aluminum and in the middle of the 90's the PVC windows frames appeared in the market. After early 90's, most of the windows have double glaze (6+12+6 mm) and the glass is clear on both sides in all facades;
- Roofs: pitched roofs and/or flat roofs (mainly in the South). Until the 80's the standard was the ventilated roof with ceramic tiles laid on a wooden frame structure, without any insulation. Actually the pendant of the roof is made of a pre-stressed T-beams and ceramic blocks slab, constituting a non-ventilated attic. The biggest part of roofs built after the early 90's has an insulation layer.

The main problems identified in the Portuguese building envelopes were the low thermal insulation and insufficient sound insulation, mainly in buildings built before the early 90's. The poor thermal behaviour is related with the high U-values of the envelopes. The major part of the envelopes built until the early 90's, about 80% of the total actual residential units, do not have insulation and the window frames have high air permeability and are single glazed. The poor air born sound insulation of the façades is commonly related to the bad quality of the fenestration

(single glaze windows and high air permeability window frames). This situation becomes significantly improved after the publication, in 1991, of the actual thermal legislation.

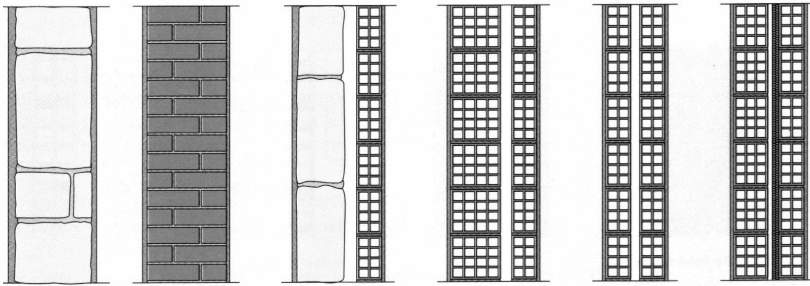

Figure 1. Evolution on the exterior walls construction solution in Portugal (APICER¹, 1998).

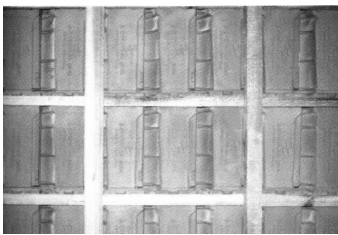

Figure 2. Ceramic tiled roof laid on a wooden frame structure, constituting a ventilated attic (APICER², 1998).

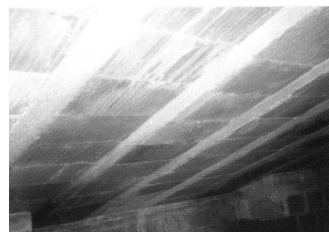

Figure 3. Pitched roof structure made of pre-stressed T-beams and ceramic blocks slab, constituting a non-ventilated attic (APICER², 1998).

1.2 Requirements in Portugal that enforce a reaction to refurbish envelopes

Actual regulations (i.e. thermal and acoustical) are more demanding and they imply new ways to design buildings. At the level of thermal comfort regulation, its satisfaction is not obligatory retroactive in all buildings built before its publication. Its fulfilment it is only required in buildings submitted to a refurbishing process in which the costs exceed more than 50% of its actual value. Although, buildings built until the publication of the actual thermal legislation do not satisfy the actual users comfort requirements and they need to be refurbished.

Nowadays a new thermal legislation is being discussed in order to fulfil the European Directive 2002/91/CE. In the new thermal legislation, the requirements will be at least 40% higher than the actual one. This situation is enforcing to study and find new construction/refurbishing solutions that will meet these new requirements. Table 1 shows the standard and future requirements for the thermal insulation of building envelopes. Until 1991 there was no regulation about this issue.

On the other hand, it will be necessary to refurbish the actual building stock in order to reduce the energy consumption on it and meet the aims and goals for sustainable development, particularly at the level of the CO₂ emissions and economic sustainability. At the moment, the energy consumed in Portuguese buildings is about 25% of the total energy consumption, and in the last years this value is increasing a lot. Portugal signed the Kyoto Protocol and now, more than ever, it is necessary to refurbish these façades in order to archive its goals.

Table 1. Standard and future requirements of heat transfer coefficient (U-value) in Portugal.

Partition Element	D.L. 40/90 Valid from 1991		D.L. ⁽¹⁾ Valid from 2006	
	Maximum U-value (W/m ² .°C)	Reference U-value (W/m ² .°C)	Maximum U-value (W/m ² .°C)	Reference U-value (W/m ² .°C)
Walls				
Climate zone I ₁	1.80	1.40	1.80	0.70
Climate zone I ₂	1.60	1.20	1.60	0.60
Climate zone I ₃	1.45	0.95	1.45	0.50
Roofs				
Climate zone I ₁	1.25	1.10	1.25	0.50
Climate zone I ₂	1.00	0.85	1.00	0.45
Climate zone I ₃	0.90	0.75	0.90	0.40
Windows				
Climate zone I ₁	-	4.20 ⁽²⁾ /5.80 ⁽³⁾	-	4.30
Climate zone I ₂	-	4.20 ⁽²⁾ /5.80 ⁽³⁾	-	3.30
Climate zone I ₃	-	4.20 ⁽²⁾ /5.80 ⁽³⁾	-	3.30

⁽¹⁾The new thermal legislation will be published in the second half of 2006.

⁽²⁾Buildings that are used during the night (dwellings, hotels, hospitals, etc.).

⁽³⁾Other buildings.

2 SPECIFICATIONS OF THE TECHNICAL SOLUTION

The most used refurbishing solutions for vertical envelopes in Portugal are: the External Thermal Insulation Composite Systems (ETICS), the Ventilated Façades and the replacement of existing windows by double glazed and low air permeability ones. In this paper, the potentialities of the ventilated façade as a refurbishing solution, mainly for buildings built from the 70's, will be assessed.

2.1 *Ventilated coated façades*

The ventilated façade is composed, from exterior to interior, by a floating covering material, after which there is an air cavity, where a layer of insulation is installed, and finally the support structure (existing wall). The covering material is fixed into the supporting structure using a steel frame structure and anchoring devices. The air cavity that exists between the cladding and the insulation creates, due to the "stack effect", effective natural ventilation, with remarkable benefits to the entire system.

Placing a floating covering material in the external surface of the existing vertical external envelopes is one solution to improve their thermal and sound insulation.

Compared with the other refurbishing solutions applied directly to the wall structure, the advantages of a ventilated façade are:

- Reduced risk of cracking and detachment;
- Easy installation: elements are assembled "dry" on site without the use of adhesives, by means of mechanical-type fitting and anchoring devices;
- Lower maintenance: work may be carried out separately on each individual cladding unit;
- Higher durability: the wall structure is protected against direct climate loads. This way its durability is generally high;
- Higher energy-saving: all construction mass of the wall structure is available for the interior thermal inertia and there aren't thermal bridges.
- Higher moisture control: elimination of surface condensations on the insulation (the presence of an air cavity helps expelling water vapour from inside, reducing dampness caused by infiltration).

The functional elements that form the ventilated façade, as presented in figure 4, are:

- Support structure: existing wall. This system is best suited for load-bearing walls;
- Regularisation layer: 1-2 cm-thick plastering. It has the function of reducing all irregularities on the surface of the underlying layer;

- Insulating layer: 3 to 8cm thick layer applied directly to the wall structure using glues and/or mechanical elements. The most common used materials are: polyurethane foam; expanded polystyrene and extruded polystyrene;
- Ventilation layer (air cavity): 3 to 5cm;
- Anchoring system: composed by an integrated set of elements with the static function of attaching the floating cladding to the building structure. The anchoring system may be made up of metallic or wood structural frame (spread fixing) or of anchors located in certain points (local fixing), and visible and not-visible solutions are available (figures 5 to 7);
- Cladding layer: to protect the building structure from direct climate loads and to (re)define the building aesthetics. The most common materials are: natural stone, man-made stone, ceramic, terracotta, plastic or metallic materials, oriented strand board (OSB), glass (transparent and opaque) and wood fibre board with Portland cement.

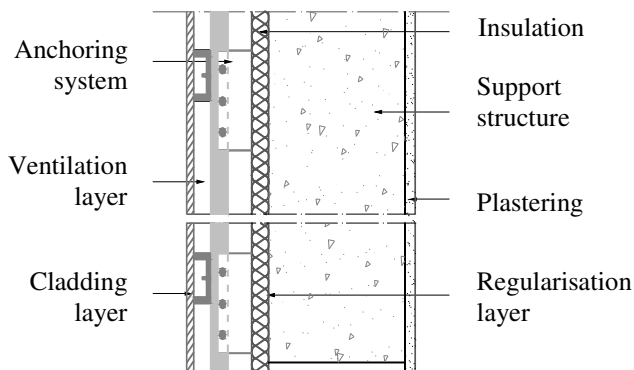

Figure 4. Cross section of a typical ventilated curtain wall (Mateus, 2004).

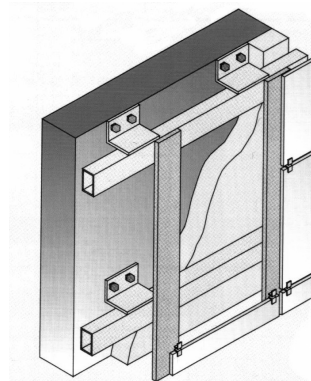

Figure 5. Detail of a typical visible spread metallic anchoring system (APICER, 2003).

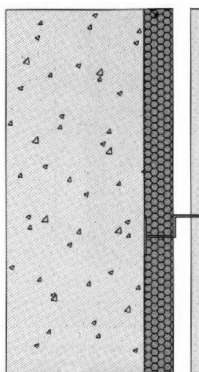

Figure 6. Detail of a typical visible local metallic anchoring system (APICER, 2003).

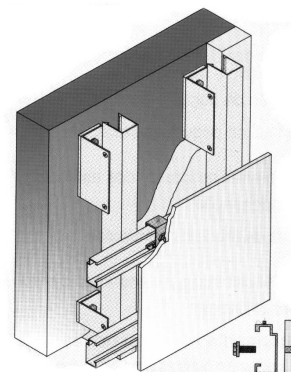

Figure 7. Detail of a typical not-visible spread metallic anchoring system (APICER, 2003).

3 THE IMPACT OF THE REFURBISHMENT ACTION ON SUSTAINABILITY TOPICS

3.1 Technical performance

The building solutions used in curtain façades should be certified as prescribed in EN 13830. According to this European Norm, the performance characteristics that should be accessed in curtain walls are:

1. Fire resistance;
2. Reaction to fire;
3. Fire propagation;
4. Watertightness;

5. Dangerous substances;
6. Wind load resistance;
7. Resistance to own dead load;
8. Impact resistance;
9. Resistance to horizontal loads;
10. Thermal shock resistance;
11. Acoustic performance;
12. Thermal resistance;
13. Water vapour permeability;
14. Air permeability.

3.1.1 *Stability, capacity, (earthquake)*

The cladding of this wall is not load-bearing. Although it is designed to accommodate structural deflections, control wind-driven rain and air leakage, resist to wind horizontal loads, minimize the effects of solar radiation and provide for maintenance-free long term performance.

Movements of the structural elements of a building must be determined prior to the design of an exterior wall system. Movements may be grouped into three types (Quirouette, 1982):

1. live load deflections due to occupancy loads or peak wind loads on the building façade, and dead load deflections of the building structure;
2. expansion and contraction of materials as a result of temperature, radiation and sometimes hygroscopic loading;
3. slow but inexorable movements due to gradual deformation, such as creep in concrete, foundation settlement, etc.

This refurbishing solution can be used in any type of façade. Although, it's necessary to have in mind that the material used as wall structure influences the stability of the anchorages, thus influencing the wall stability. Soriano (1999) studied the influence of the material used in the wall structure in the anchorage system stability, and the results are shown in Table 2.

Table 2. Reliability degree of the material used as wall structure in the stability of the anchorage system (Soriano 1999).

Material	Reliability
Reinforced concrete	Excellent
Solid brick	Very Good
Perforated brick	Good
Cement brick	Good
Light ceramic brick	Good
Hollow brick	Unacceptable

Although not a frequent cause of failure, building movements are not adequately considered in the design and construction of façades.

As higher is the cladding and fixing system's rigidity as bigger are the problems found at this level. In the glass panel cladding the problems related to the movements of the wall structure should be particularly studied in order to avoid the collapse of any cladding unit. The problems are also worst when the dimensions of the cladding units are higher.

To avoid the problems related to the cladding's expansion and contraction, the joints between the units should have a compatible thickness. When a sealant is used in the joints, its modulus of elasticity should be compatible to the movement requirements. Low modulus sealants (remaining soft after cure) are suitable when movement is required, as in the case of metal curtain-walls. High-modulus sealants are best suited in cases such as structural glazing where high strength is required and movement is limited.

The building movement resulting in compression, expansion and parallelograming of the frames must be accommodated by the fixing system. In a typical curtain wall system of structural mullions, the fixing system should allow a differential movement of about 4 to 5mm on a floor to floor basis and between each vertical riser (Quirouette, 1982). If greater

movements are expected, the fixing system must be compatible with it. This situation leads to more complex detailing and usually a disproportionate increase in the system cost.

3.1.2 Fire protection

When a ventilated curtain wall is built, an air cavity is created at the intersection of the floor assembly and the wall structure (interior face) of the curtain wall. The air cavity is a way for fire propagation from lower to upper floors. In order to prevent this risk, this cavity must be sealed along the perimeter of the building.

The material and system used in the perimeter must be capable of preventing the passage of flame and hot gases for a time period at least equal to the fire resistance of the floor assembly. Air cavities of a range of widths could be sealed with fire resistive non-combustible materials such as mineral wool blankets.

Figure 8 illustrates a typical detail of the air cavity and the sealing material between the slab and the curtain wall (MCA, 2003).

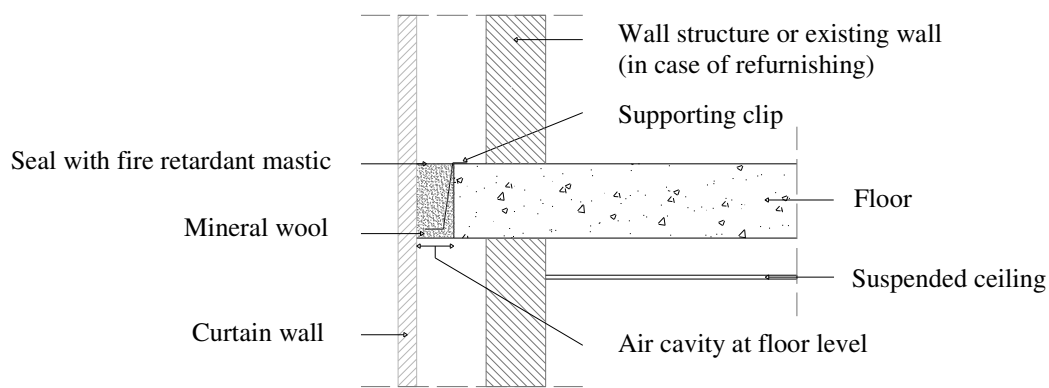

Figure 8. Exterior curtain wall at the level of floor intersection (air cavity sealing)

3.1.3 Noise protection

In this type of wall the cladding doesn't adhere directly to the supporting structure. Therefore, the airborne sound insulation is greatly improved compared to other building solutions with the same mass. Some problems of vibrations were identified in these walls, mainly when the cladding material's rigidity is high and or its mass is low (e.g. glazed curtain walls). In order to prevent this kind of problems, that could compromise the global sound performance, it's necessary to introduce a resilient material between the cladding and the fixing system.

3.1.4 Moisture protection

a) Protection to rainwater

The penetration of rainwater through walls depends on the following combination of conditions (Chown, 1997):

1. the presence of water;
2. openings in the assembly that permit water to enter;
3. forces that can move water through the assembly.

The control of rainwater penetration depends on being able to control any one or all of these conditions. Over time, rain penetration has been controlled in various ways ranging from massive masonry construction to pressure-equalized rainscreen (PER) curtain-wall assemblies. In curtain walls the moisture protection is improved through the rainscreen principle: the presence of a drained and ventilated air cavity between the cladding and the wall structure

permits the reduction of moisture load on the back-up wall. The air cavity permits the removal of moisture transferred from both the exterior and interior.

b) Protection to condensations

Water in its gaseous phase (water vapour or humidity) always tries to migrate from a region of high water vapour pressure to a region of lower pressure. The migration of water vapour through a wall can be compared to heat flow; it moves through all materials at a rate that is dependent on both the resistance of the materials to water vapour flow and the difference in water vapour pressure on both sides of the material. In winter the water vapour migrates from inside to outside and it generally condenses to water in the exterior surface of the insulation. The stack effect on the air cavity removes the humidity and prevents long contacts with the wall structure materials.

3.1.5 *Conductivity, heat flow*

The heat flow control is generally achieved through the use of insulation. This system uses considerable insulation, usually behind spandrel glass or any opaque panels, although it is not visible from the exterior. Due to the high conductivity of some materials used as cladding, p. e. glass and metal, the system must also contend with potential condensation on the interior surfaces.

One of the biggest advantages of this system is that the insulation is continuous. Therefore the thermal bridges in the structural elements areas are avoided. Another advantage of this kind of insulation is that all the wall structure's mass is available for the indoor thermal inertia.

3.1.6 *Durability*

The solar radiation is one of the major external agents that influence the durability. On this system the most important concerns related with solar radiation are the thermal expansion and contraction of curtain wall components, in particular those forming the outside cladding. Therefore, the durability of this kind of wall depends, above all, in the type of material used as cladding: the longevity of aluminium panels is reduced by corrosive urban pollution, acid rain and salty air; the pre-cast concrete panels often cracks; fibberglass reinforced panels loose strength over time as the alkaline-rich cement attacks the glass reinforcement. The durability of the OSB panels is limited due the destructive effects of ultraviolet radiation in the organic materials. The biggest advantage of this system, at the maintenance level, is the possibility of replacing any cladding unit without moving the others.

3.2 *Functional/social and economical performance*

As stated before, several solutions and different materials could be used to build this system. This way, its functional, economic and environmental performances depends above all on the type of materials that were used on it. This way, the performance of this system, at these levels, will be assessed in the case study.

4 CASE STUDY

4.1 *Description of the building solutions*

The building solution accessed in this study is one of the most used solutions in multi-storey building façades, built in Portugal from the 70's until the early 90's. The solution is a hollow brick cavity wall (11+11cm) with a 4cm thick air cavity. Each surface of the wall is covered by a 1,5cm thick layer of render. This solution doesn't have the necessary performance to fulfil the actual user's comfort requirements and the new thermal regulations. Figure 9 shows the wall cross section before the refurbishing process.

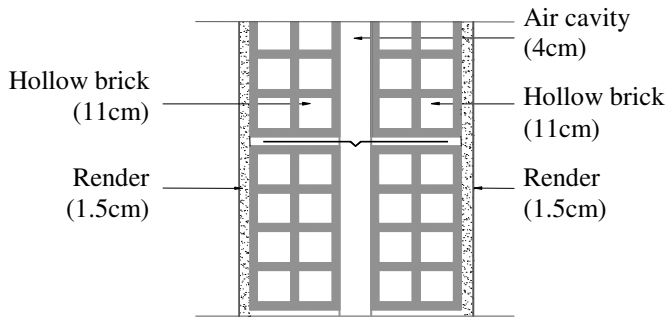

Figure 9. Cross section of the wall (before refurbishing).

The assessed refurbishing process consists in the placement of a 4cm thick continuous thermal insulation layer of agglomerated cork and in the assembly of a 1,0cm thick ceramic cladding. The anchoring solution is a structural system composed by galvanized steel elements and the air cavity between the insulation and the cladding is 4cm thick. The joints between the cladding units are sealed. Figure 10 presents the wall's cross section after the refurbishing process.

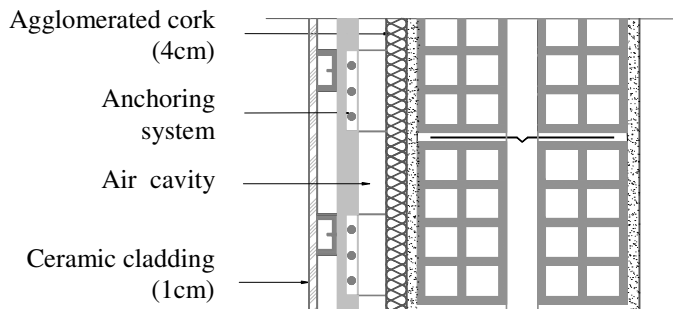

Figure 10. Cross section of the wall (after refurbishing).

4.2 Functional/social performance

4.2.1 Flexibility

This kind of refurbishing solution can be adopted in near to all building systems, therefore its flexibility it's very high.

In non load-bearing walls this system could be easily placed if the anchoring system is connected directly to the building's beams and columns. In load-bearing walls or when it's not possible to connect the anchoring system directly to the building's structure it is necessary to verify if the original wall has the necessary structural stability to support it.

Since the system is mechanical fixed to the existent wall, in this solution it's easy to replace any cladding unit or the entire system.

4.2.2 Comfort

a) Thermal

The placement of an insulation layer turns the U-value lower after the intervention. Table 3 shows the U-value of this wall before and after the process.

Table 3. Heat transfer coefficient (U-value) of the wall before and after the refurbishing process.

U (W/m ² . °C)	
Before ⁽¹⁾	After
1.40	0.62

⁽¹⁾In the evaluation of this value the thermal bridges were not considered. Considering it the difference would be greater.

b) Acoustical

The airborne sound insulation curve of the building solution, before and after the refurbishing, is assessed using the analytical methodology proposed by Meisser (1973). The airborne sound insulation index ($D_{n,w}$) was quantified adjusting a reference curve to the result, as prescribed in NP-2073 (Portuguese normalization). As shown in figures 11 and 12, after the refurbishing the $D_{n,w}$ (f=500 Hz) is improved in about 4 dB.

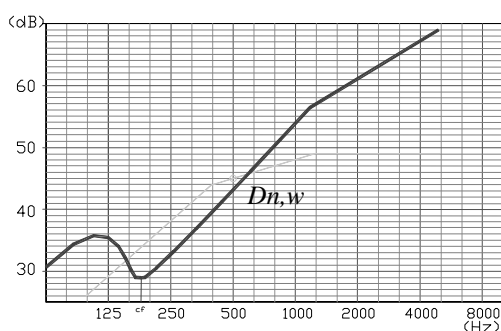

Figure 11. Airborne sound insulation curve (before refurbishing).

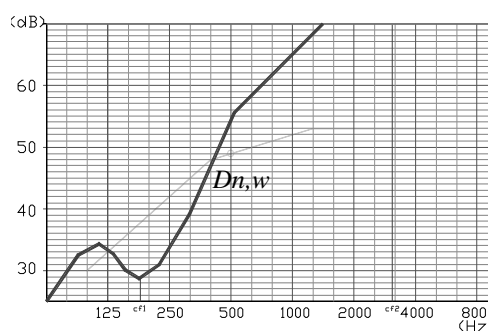

Figure 12. Airborne sound insulation curve (after refurbishing).

4.2.3 Health

In this refurbishing solution, no health hazards were identified during the construction phase: this intervention is made at the exterior of the building; therefore it doesn't directly affect the indoor air quality. During the operation phase, the application of a ventilated façade is useful to increase the thermal insulation, superficial indoor temperature and to reduce the condensation and avoid the formation of moulds. These factors are important for the inhabitant's health.

4.2.4 Barrier free

Comparing to other refurbishing solutions (e.g. ETICS), the smaller number of companies specialized in this type of system and the lack of specialized workmanship, increases its cost and reduces its competitiveness.

4.3 Economical performance

Comparing this refurbishing technology with other technologies, its construction cost is much higher.

Although, in the economical performance assessment it is necessary to evaluate, not only the cost of each building material and the related workmanship, but also all other costs and benefits related to the solution's life cycle. This way, it must be enhanced that the higher construction costs could be compensated with lower maintenance costs (as presented before, the maintenance operations are easy in this solution). Another factor that might influence this

comparison is the residual value: this solution as a great residual value, since the biggest amount of its elements could be directly reused in another building or easily recycled. An average cost for a ventilated façade in Portugal is bounded between 75€/m² (ceramic cladding and local metallic anchoring system) and 500€/m² (aluminium cladding).

4.4 Environmental performance

4.4.1 Energy consumption

The amount of energy needed to produce materials, their assembly in construction site, maintenance and demolition, it is bounded between 6 to 20% of the total energy consumed during the entire life-cycle of a building, depending, among others, on the used building technologies, number of users, climate and comfort level demanded by the occupants (Berge, 2000). About 80% of this value corresponds to the materials Primary Energy Consumption (PEC), what means the energy resources spent for its production, including the energy directly related to the extraction of raw materials, their processing and the energy needed for their transport. The remaining 20% includes the energy consumed in the transport of the transformed materials to the construction site, the energy consumed during the building construction and the consumed energy during the dismantling and demolition processes.

The assessment of the total embodied energy in building materials is one of the dimensions to consider in the environmental performance evaluation. Table 4 shows the building mass and the PEC, per each square meter of this refurbishing solution.

Table 4. Solution's mass and total Primary Energy Consumption (PEC).

Material	Curtain wall mass	PEC ⁽¹⁾	PEC
	kg/m ²	kW.h/kg	W.h/m ²
Steel (50% recycled)	5 ⁽²⁾	4.86	24.30
Agglomerated cork	5	1.11	5.55
Ceramic tiles	25	2.22	55.50
Total	35	-	85.35

⁽¹⁾ Source: Berge, 2000 (presented values are for Central Europe).

⁽²⁾ Estimated value. It depends on the type of the anchoring system (visible/not-visible and local/spread fixing).

The energy needed to guarantee the users comfort level will be much lower, since, after the refurbishing, the thermal losses and gains through the wall are about 45% of their initial value (Table 3).

4.4.2 Environmental impacts

Table 5 presents the results found in the environmental impact assessment. In Portugal, up till now, local life-cycle inventory (LCI) data about building materials it is not available; therefore the results are based in values studied by Berge (2000) for Central Europe. For Portugal this values should be slightly different.

Table 5. Environmental impacts of the refurbishing solution

Material	Environmental impacts						
	Mass kg/m ²	Water ⁽¹⁾ m ³ /m ²	Waste ⁽²⁾ kg/m ²	GWP ⁽³⁾ kg/m ²	AP ⁽⁴⁾ kg/m ²	COD ⁽⁵⁾ kg/m ²	POCD ⁽⁶⁾ kg/m ²
Steel (50% recycled)	5	17.00	1.50	3.15	0.03	2.11	2.11
Agglomerated cork	5	0.12	0.00	1.39	0.00	0.01	0.01
Ceramic tiles	25	10.00	0.25	14.28	0.10	1.28	1.28
Total	35	27.12	1.75	18.82	0.13	3.40	3.40

⁽¹⁾ Water = Water used in the production process.

⁽²⁾ Waste = Waste from the production process.

⁽³⁾ GWP = Global Warming Potential in kilograms CO₂ equivalents.

⁽⁴⁾ AP = Acidification Potential in kilograms SO₂ equivalents.

⁽⁵⁾ COD = Chemical Oxygen Depletion in grams NO_x.

⁽⁶⁾ POCP = Photochemical Ozone Creation Potential in kilograms NO_x.

4.4.3 Waste production

The best way to deal with the residues in construction is, in first place, to avoid them. After, recycling the largest amount of material must be considered. Incineration and deposition in waste deposits should also be avoided. This building/refurbishing technology is characterized by a great industrialization of the building process, being most of its elements prefabricated. The controlled production process results in the reduction of residues. The elements are produced with the exact dimensions needed to carry out their functions, not giving place to wastes.

Another major source of residues in construction takes place in the demolition/dismantling phase. In this solution the building materials/elements are punctually joined, being easy to separate during dismantling. On the other hand the biggest amount of materials can be easily reused or recycled, for instance, the steel profiles can be easily reused in another building or 100% recycled.

5 CONCLUSIONS

There are few examples of technical solutions that are being adopted in Portugal to improve the quality of the multi-story buildings envelopes. Two examples are the external thermal insulation composite systems (ETICS) and the ventilated façade.

This paper presented the potentialities and limitations of the ventilated façade as a refurbishing solution to upgrade the functionality of the conventional buildings façades. This study showed that this technical solution is suitable to improve several different functional aspects of the façade, e.g. thermal and noise insulation and moisture protection (from rainwater and condensations). The main limitation of this solution, compared for instance to the ETICS, is the higher construction cost. This limitation can be compensated with the higher durability and lower maintenance costs of this solution.

Besides the functional and economic performance, the environmental performance of this technical solution was assessed in order to study its impacts in the different dimensions of the Sustainable Development.

Analysing the data presented in this paper, comparing it with the data of other technical solutions, and weighting the different dimensions according to local constrains and objectives of the project, it is possible to evaluate the sustainability of the ventilated façade as a solution to improve the conventional façades.

As a next step, it is necessary to make experimental evaluations to buildings submitted to this refurbishment solution, and surveys to its inhabitants, in order to evaluate the real impact and performances of this technical solution.

6 REFERENCES

- APICER1 (1998). Manual de Alvenaria de Tijolo, Associação Portuguesa da Indústria de Cerâmica, Coimbra.
- APICER2 (1998). Manual de Aplicação de Telhas Cerâmicas, Associação Portuguesa da Indústria de Cerâmica, Coimbra.
- APICER (2003). Manual de Aplicação de Revestimentos Cerâmicos, Associação Portuguesa da Indústria de Cerâmica, Coimbra.
- Berge, Bjorn (2000). Ecology of Building Materials, Architectural Press, Oxford – translated from the original “Bygnings materialenes okologi”, Universitetsforlaget, Norwege.
- Chown, G. A. et al (1997). Evolution of Wall Design for Controlling Rain Penetration, Construction Technology Update No. 9, IRC – Institute for Research in Construction.
- Quirouette, R.L. (1982). A Study of the Construction Process, Division of Building Research, National Research Council of Canada, Building Practice Note 32.
- Mateus, Ricardo (2004). Novas Tecnologias Com Vista à Sustentabilidade da Construção. MSc Thesis in Civil Engineering, University of Minho, Engineering School, Guimarães.
- Meisser, Mathias (1973). Acústica de los Edifícios. Editores Técnicos Associados, S.A., Barcelona - translated from the original “La Pratique de L’Acoustic dans les Batiments”, S.D.T.B.T.P., Paris.
- MCA (2003). Exterior Curtain Wall /floor intersection. MCA – Metal Construction Association (USA), March. <http://www.metalconstruction.org/>, online in 2005/04/27.
- Soriano, A.L.R. de (1999). Aplacados Pétreos en Fachadas Ventiladas, Col·legi d’Arquitectes de Catalunya. <http://coac.net>, online in 2000/12/09.