

Figure 8. Forces between two parallel conductors

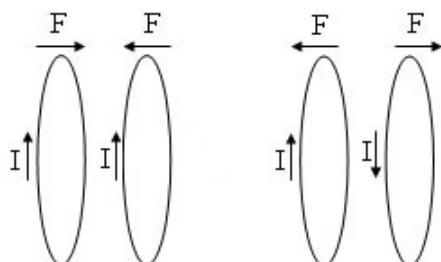

Figure 9. Resulting forces between two rings of the coil

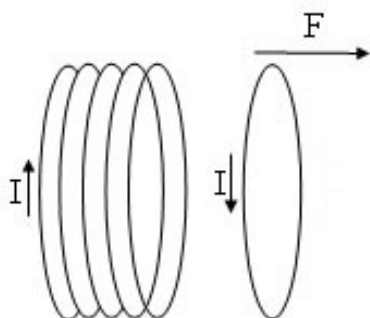

Figure 10. Resulting force in a ring

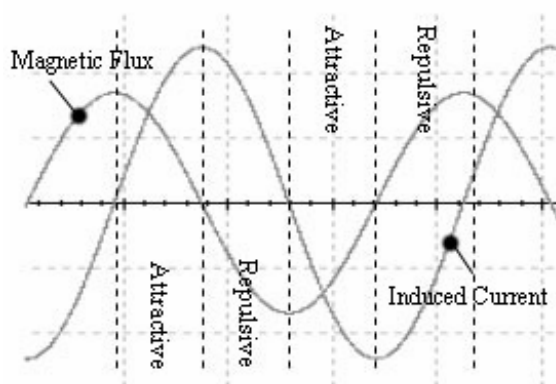

Figure 11. Resulting forces in a period of time

7. Conclusions

A device capable of throwing metal rings at a range of a few meters has been presented. The physical principles that rule its operation were briefly introduced. Also, some construction details have been given. The experiment is very appropriate to demonstrate Electromagnetism laws in science fairs and hands-on classes.

8. References

- [1] Famous Electrochemists
<http://chem.ch.huji.ac.il/~eugeniik/history/electrochemists.htm>
- [2] Plonus, Martin A.; Applied Electromagnetics. McGraw-Hill, 1986.
- [3] Mendiratta, Sushil Kumar. Introdução ao Electromagnetismo. Fundação Calouste Gulbenkian, 1984.
- [4] Coilgun Systems
www.coilgun.eclipse.co.uk
- [5] Silveira, Fernando Lang da. Explicação Qualitativa do “Anel do Thompson”. Como Ocorre a “Levitação Magnética?”. Revista Brasileira de Ensino de Física, vol 25, no. 1, Março, 2003.

Miniature Thermoelectric Power Plant

Antonio Moreira, Ricardo Freitas
and João Sena Esteves

Dept. of Industrial Electronics, University
of Minho, Campus of Azurém, 4800-058
GUIMARÃES, Portugal
ant0ni0_m0reira@hotmail.com;
ricardo_filipefreitas@hotmail.com;
sena@dei.uminho.pt

Abstract This paper describes a miniature thermoelectric power plant made with the boiler and the water pump from an old starch iron. It also uses a computer cooling fan, which serves as electric power generator. The boiler vaporizes the water it receives from the water pump. Then, the steam is injected over the turbine of the fan making it twirl. The voltage generated by the fan is enough to lighten a couple of LEDs. A wooden case with a chimney encloses all the referred devices.

Keywords. Electrical Power Systems, Thermoelectric Power Plant.

1. Introduction

Electric energy availability has become of primordial importance in modern societies. In fact, it is so important that its fail can stop a whole city: modern trains, hospitals and industries, for example, would stop without electric energy. There are several ways to produce electric energy (for example, through hydroelectric, thermoelectric or wind power plants [1,2]). This paper describes a miniature steam thermoelectric power plant (Fig. 1) made with old starch iron parts.

2. Power plant operation

This section describes the functioning of the main components of the power plant, which were:

- 1 water pump
- 1 boiler of a starch iron
- 1 electrical valve
- 1 computer cooling fan
- 1 water tank
- 1 ejector
- 2 LEDs
- 2 resistor of 500 Ω
- 2 position button
- 1 Pressure button
- 1 Teflon pipe

Additional materials were, among others, a cork sheet, a wooden base and spray paint.

2.1. Water pump



Figure 1. Miniature thermoelectric power plant

The water pump (Fig. 2) is needed to pump water from the water tank to the boiler, so that can be transformed into steam. The pump works with 220V.



Figure 2. Water pump

2.2. Boiler

The boiler (Fig. 3) works with 220V and its power is 1350W. The current absorbed by the boiler is 6A. The pressure inside of the boiler is approximately 3 bar.

When the temperature inside of the boiler is higher than 105°C, a LED placed near the buttons is on (see figure 5) to indicate that the boiler is heating up.

When the temperature arrives to 120°C, the LED is switched off and the boiler starts to cool down. Now, the button of the ejector is ready to be switched on, freeing the water steam through the fan.

The boiler has an electrical valve that cuts current when the temperature inside of the boiler arrives to 200°C.

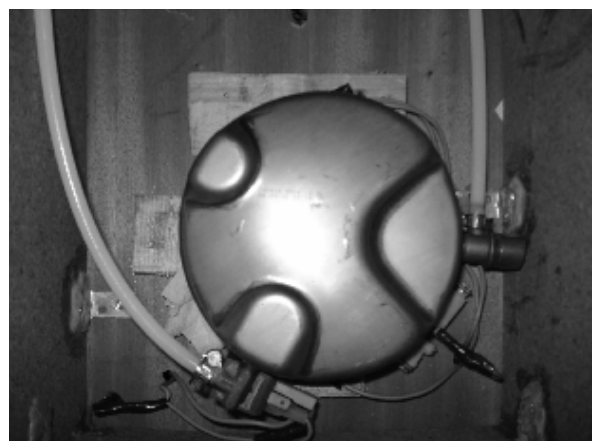

Figure 3. Boiler

2.3. Computer cooling fan

The fan used in the miniature is a 12V computer cooling fan, installed inside the power plant chimney (Fig. 4). When the water steam leaves the ejector, the fan starts turning, generating voltage at its terminals. When the voltage is enough, two LEDs connected to the fan terminals lighten up. The ejector is pointed in a way such that the voltage at the terminals of the fan is as high as possible.

2.4. Buttons

The miniature has three buttons (Fig. 5), two of position and one of pressure. The pressure button (Button 2) corresponds to the water pump. When it is pressed, it switches the pump on, filling the boiler with water. Button 3 is needed to turn on or off the boiler. Button 1 opens the ejector so that the water steam may go to the fan.



Figure 4. Fan inside the chimney

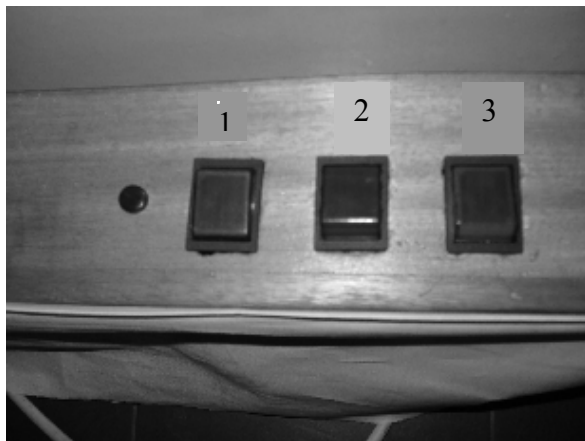

Figure 5. Buttons

2.5. Electrical outline

Figure 6 depicts the outline of the electrical circuit used in the miniature.

3. Tests and construction details

Before the construction of the miniature thermoelectric power plant, several tests were performed in order to verify the reliability of the materials used.

First, the boiler was filled using the water pump. Then, through a pipe of Teflon, the boiler was linked to the ejector. The pipe of Teflon was used because the temperature of water steam in the output of the boiler is higher than 100°C and pressure is, approximately, 4 bar (value not measured). The pipe tolerates temperatures up to 200°C and 10 bar pressures.

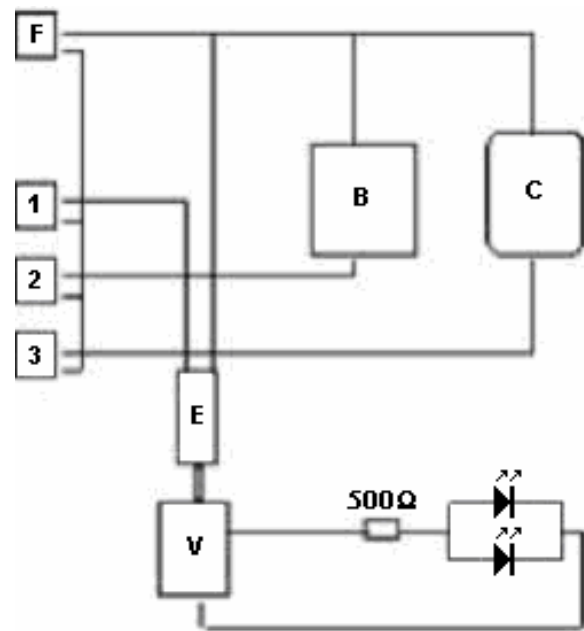

- F – Power source
- 1 – Ejector button
- 2 – Water pump button
- 3 – Boiler button
- E – Ejector
- V – Computer cooling fan
- C – Boiler
- B – Water Pump

Figure 6. Electrical outline

The next step was testing the voltage generated at the terminals of the fan by the passing steam. The maximum peak voltage obtained was 2.5V. The series made with a 500 Ω resistor and two LEDs in parallel was connected to the terminals of the fan. The resistor was required to limit the current in LEDs.

The power plant has a very poor efficiency. In fact, the current required to heat the water is 6A, resulting in a 1320W input power.

When the tests phase concluded, the construction of the structure was initiated. First, the walls of the miniature were constructed and painted with spray. Then, the boiler was fixed in the wooden base. The next step was the construction and painting of the roofs and the chimney (this latter that was painted in white and red). Finally, the ejector and the fan were fixed inside the chimney.

Part of the water steam used in the energy generation turns back into water inside the chimney and returns to the water tank.

4. Conclusions

A miniature steam thermoelectric power plant was presented. It was built using old starch iron parts and a computer cooling fan. Construction and operation details were explained. The voltage generated by the power plant is enough to lighten two LEDs. Despite of its very poor efficiency, the device is eye-catching and very suitable for science fair events.

5. References

- [1] Brandão, Diogo de Paiva Leite. *Electrotecnia Geral*. Fundação Calouste Gulbenkian, 1987.
- [2] Matias, José Vagos Carreira. *Tecnologias da Electricidade – Vol. I* (6th ed.). Didáctica Editora, 2003.

Microcontroller-Driven Hydrogen Car

Hugo Queirós, Antonio Lafuente and João Sena Estevez
Dept. of Industrial Electronics. University of Minho.
Campus of Azurém. 4800-058 GUIMARÃES Portugal.
hugoqueiros@netcabo.pt;
dookei@netcabo.pt; sena@dei.uminho.pt

Abstract. This paper presents a hydrogen-powered car with 8 minutes autonomy. The hydrogen is produced by electrolysis, which requires an external power supply. The gas is retained on an isolated compartment in the car. Then, it goes to the fuel cell, which produces the energy for the car motor. The car follows a white line on a black track using five infrared sensors that detect white and black colors. A servomotor controls its direction. Guidelines to the servomotor are given by a system based on an 8051 microcontroller, according to the information it receives from the infrared sensors.

Keywords. Fuel Cell, Infrared Sensors, 8051 Microcontroller, Hydrogen, Electrolysis.

1. Introduction

The project described in this paper applies fuel cell technology [1, 2] to a model car.



Figure 1. Hydrogen powered car

To control the vehicle, more conventional technologies were used. Infrared sensors and an 8051 microcontroller are some of the components integrated in the control system.



Figure 2. Car track

Since the hydrogen car (Fig. 1) is very suitable for science fair events – its appearance at *Robótica 2006* festival was a success – an oval track (Fig. 2) was built for exhibition purposes.