

## The challenging modelling of $k_La$ in a periodic constricted small-scale tube

N. Reis, A.A. Vicente\* and J.A. Teixeira

<sup>a</sup>Centro de Engenharia Biológica, Universidade do Minho, Campus de Gualtar, 4710-057 Braga, Portugal. Phone: +351.253.604400; Fax: +351.253.678986

### Abstract

An extensive use in chemistry, biological and pharmaceutical laboratories is envisaged for a novel continuous screening reactor based on the oscillatory flow technology (Harvey, 2001). The basic unit of this reactor was recently presented by Harvey et al. (2003) and Reis et al. (2004) and consists in a 4.4 mm internal diameter and 350 mm long jacketed glass small-scale tube provided with smooth periodic constrictions, SPCs (Figure 1). Prediction of fluid mixing and residence time within this tube were successfully achieved with CFDs (Harvey et al. (2003) and Reis et al. (2004)), but modelling of oxygen mass-transfer coefficient forecast as a very challenging task.

Physical properties, sparger and column configuration, agitation/oscillation intensity, superficial gas velocity, all affects  $k_La$ , controlling the properties of gas-phase: bubble size, bubble velocity/residence time and gas hold-up. In all, the overall volumetric mass transfer coefficient,  $k_La$  can be affected by the mass transfer coefficient,  $k_L$  or by the interfacial area,  $a$ .

Previous work with this novel reactor (Reis et al., in Proceedings of 16<sup>th</sup> CHISA, 2004) demonstrated improved oxygen mass transfer rates. The modelling of  $k_La$  requires a good understand of liquid and gas-phase behaviours. The application of oscillatory flow motion to the constricted tube induced significant modification in bubbles trajectories, resulting in complex liquid-bubble mixing pattern, and made breakage and coalescence of bubbles become regular events in each cavity. Those patterns switch with the increase of mixing intensity (either by increasing the oscillation frequency and/or amplitude) in several regimes (Figure 2), in the same way as in conventional oscillatory flow reactors (OFRs): initially, bubbles move upward, but with the increase of oscillation intensity bubbles start to move downwards in certain phases of the oscillation cycle. At intensive levels of oscillation, rising bubbles are trapped within each cell for several seconds thus staying in each cavity longer due to the motion of vortices as compared with a bubble column. It was found that bubble size and hold-up contribute to the measured mass transfer enhancement but is the combination of small bubbles with the tortuous routes for bubbles to travel that promotes enhanced mass transfer. Moreover, the small-scale of the tube associated with the 1.6 mm internal diameter of the constriction walls, makes the Taylor flow of gas bubbles contribution an important variable, requiring (or not) to be considered in  $k_La$  modelling. This question is bringing into discussion.

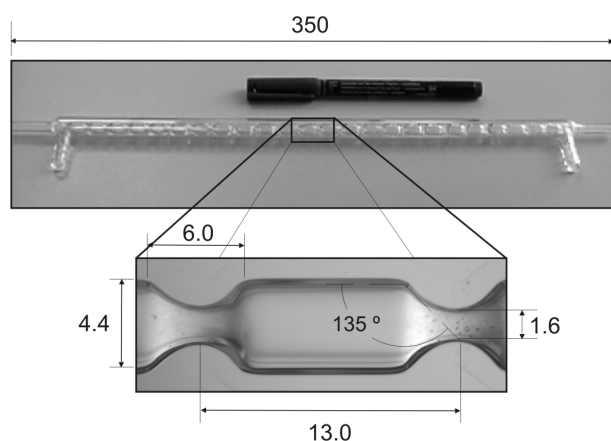

Figure 1. Geometry of a single SPC tube.  
All units are in millimetres.

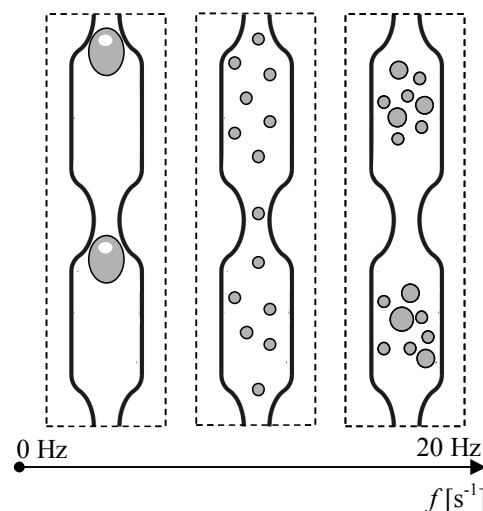

Figure 2. Identified bubbles behaviour with increasing  $f$ .

\* E-mail address of corresponding author: [avicente@deb.uminho.pt](mailto:avicente@deb.uminho.pt).