

Analysis and restoration of ancient masonry structures

Guidelines and Examples

PAULO B. LOURENÇO

University of Minho, Department of Civil Engineering, 4800-058 Guimarães, Portugal

pbl@civil.uminho.pt

Tel: +351 253 510 200

Fax: +351 253 510 217

The paper addresses ancient masonry structures, from the perspective of conservation, analysis and strengthening. These tasks are still a challenge to modern practitioners even if significant research advances have occurred in the last decades. Significant advances have been made in non-destructive testing, mechanical characterization, tools for advanced numerical analysis, knowledge on traditional materials and techniques, and innovative materials and techniques. Here, recent recommendations are addressed and recent case studies are presented, aiming at providing a basis for discussion and for guiding remedial measures.

Introduction

Construction history is full of examples of lack of success, see Figure 1. The importance of ancient constructions has been for long exclusively associated with the use of the building, meaning that successive changes were made to the building in order to fulfil its new function. At such times, lack of use would condemn the building to a ruin and, often, re-use of the stones elsewhere. Presently, modern societies understand built cultural heritage as a landmark of culture and diversity, which should last forever, being the task of the current generation to deliver the heritage in good shape for the generations to come. This act of culture poses high demands to engineers because deterioration is intrinsic to life (as an example the expected life of a modern building is fifty years).

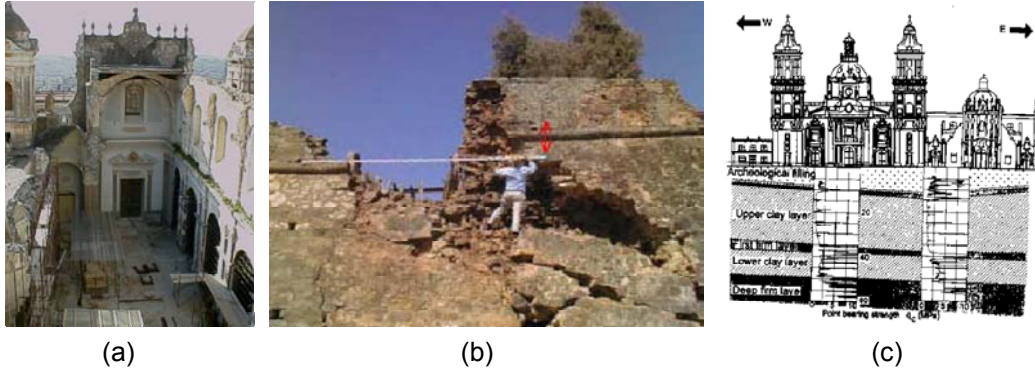

Figure 1 - Selected examples of collapse and damage in ancient constructions:
 (a) Cathedral of Noto, Italy; (b) Castro Marim wall, Portugal;
 (c) Cathedral of Mexico-City, Mexico

Only during the last decades the idea that old and ancient buildings could be restored and reused became appealing for the market. In fact, the present policy is not only to preserve but also to make buildings and the whole historic part of the cities alive, functioning and appealing to the inhabitants and to the tourists. It is the unique atmosphere of narrow streets and historic squares that provides a meaning to the cultural heritage of city centres, which must be the everyday reality for the local population. In fact, the value and authenticity of the building heritage cannot be based on fixed criteria because the respect due to all cultures and authenticity of all cultural properties also requires that its physical heritage is considered within the cultural context to which it belongs.

Nevertheless due to the effects of aggressive environment (earthquakes, soil settlements, traffic vibrations, air pollution, microclimate, etc.) and to the fact that many old and ancient buildings and historic centres were not subject to continuous maintenance, now a large part of this heritage is affected by structural problems which menace the safety of buildings and people.

European countries have developed throughout the years a valuable experience and knowledge in the field of conservation and restoration. In recent years, large investments have been concentrated in this field, leading to impressive developments in the areas of inspection, non-destructive testing, monitoring and structural analysis of historical constructions. These developments, and the recent guidelines for future reuse and conservation projects, allow for safer, economical and more adequate remedial measures.

On the need of structural analysis

The analysis of historical masonry constructions is a complex task. Firstly, limited resources have been allocated to the study of the mechanical behaviour of masonry, which includes non-destructive in situ testing, adequate laboratorial experimental testing and development of reliable numerical tools. Secondly, and most important, the

difficulties in using the existing knowledge are inherent to the analysis of historical structures. Usually, salient aspects are:

- Geometry data is missing;
- Information about the inner core of the structural elements is also missing;
- Characterization of the mechanical properties of the materials used is difficult and expensive;
- Large variability of mechanical properties, due to workmanship and use of natural materials;
- Significant changes in the core and constitution of structural elements, associated with long construction periods;
- Construction sequence is unknown;
- Existing damage in the structure is unknown;
- Regulations and codes are non-applicable.

Conservation and restoration of historical constructions are disciplines that require specific training. The continuous changes in materials and construction techniques, that swiftly moved away from traditional practice, and the challenging technical and scientific developments, which make new possibilities available for all the agents involved in the preservation of the architectural heritage, are key aspects in the division between the science of construction and the art of conservation and restoration. Modern principles of intervention seem to include aspects like:

- Removability, as reversibility seems to be an outdated concept;
- Unobtrusiveness, minimum repair and respect by the original conception;
- Safety of the construction;
- Durability and compatibility of the materials;
- Balance between cost and available financial resources.

The consideration of these aspects is complex and calls for qualified analysts that combine advanced knowledge in the area and engineering reasoning, as well as a careful, humble and, usually, time-consuming approach. Several methods and computational tools are available for the assessment of the mechanical behaviour of historical constructions. The methods resort to different theories or approaches, resulting in: different levels of complexity (from simple graphical methods and hand calculations to complex mathematical formulations and large systems of non-linear equations), different availability for the practitioner (from readily available in any consulting engineer office to scarcely available in a few research oriented institutions and large consulting offices), different time requirements (from a few seconds of computer time to a few days of processing) and, of course, different costs. It should also be expected that results of different approaches might also be different, but this is not a sufficient reason to prefer one method from the other. In fact, a more complex analysis tool does not necessarily provide better results than a simplified tool. Key aspects to be considered include:

- Adequacy between the analysis tool and the sought information;

- Analysis tools available to the practitioner involved in the project (it is of fundamental importance that the available engineering is compatible with the analysis tools);
- Cost, available financial resources and time requirements.

The possibilities of structural analysis of historical constructions have been addressed in detail in Lourenço (2002), where it is advocated that most techniques of analysis are adequate, possibly for different applications, if combined with proper engineering reasoning. It is noted that only very recently the scientific community began to show interest in modern advanced testing (under displacement control) and advanced tools of analysis for historical constructions. The lack of experience in this field is notorious in comparison with more advanced research fields like concrete, soil, rock or composite mechanics. Therefore, it is also shown that a complete set of displacement-controlled tests can be carried out, in order to obtain the properties necessary for advanced numerical models. With this information, the sophisticated and robust models for masonry structures that are currently available can be successfully used for the analysis of historical constructions.

ICOMOS Recommendations

Structures of architectural heritage, by their very nature and history (material and assembly), present a number of challenges in conservation, diagnosis, analysis, monitoring and strengthening that limit the application of modern legal codes and building standards. Recommendations are desirable and necessary to both ensure rational methods of analysis and repair methods appropriate to the cultural context.

Therefore, an international committee has prepared recommendations, intended to be useful to all those involved in conservation and restoration problems, Icomos (2001). These recommendations contain **Principles**, where the basic concepts of conservation are presented, and **Guidelines**, where the rules and methodology that a designer should follow are discussed. More comprehensive information on techniques and specific knowledge can be found, e.g. in Croci (1998), Cur (1997), Giuffrè (1993) and Meli (1998).

Principles

The principles entail: General criteria; Research and diagnosis; and Remedial measures and controls.

A multi-disciplinary approach is obviously required and the peculiarity of heritage structures, with their complex history, requires the organisation of studies and analysis in steps that are similar to those used in medicine. Anamnesis, diagnosis, therapy and controls, corresponding respectively to the condition survey, identification of the causes of damage and decay, choice of the remedial measures and control of the efficiency of the interventions. Thus, no action should be undertaken without ascertaining the likely benefit and harm to the architectural heritage.

A full understanding of the structural behaviour and material characteristics is essential for any project related to architectural heritage. Diagnosis is based on historical

information and qualitative and quantitative approaches. The qualitative approach is based on direct observation of the structural damage and material decay as well as historical and archaeological research, while the quantitative approach requires material and structural tests, monitoring and structural analysis. Often the application of the same safety levels used in the design of new buildings requires excessive, if not impossible, measures. In these cases other methods, appropriately justified, may allow different approaches to safety.

Therapy should address root causes rather than symptoms. Each intervention should be in proportion to the safety objectives, keeping intervention to the minimum necessary to guarantee safety and durability and with the least damage to heritage values. The choice between “traditional” and “innovative” techniques should be determined on a case-by-case basis with preference given to those that are least invasive and most compatible with heritage values, consistent with the need for safety and durability. At times the difficulty of evaluating both the safety levels and the possible benefits of interventions may suggest “an observational method”, i.e. an incremental approach, beginning with a minimum level of intervention, with the possible adoption of subsequent supplementary or corrective measures.

The characteristics of materials used in restoration work (in particular new materials) and their compatibility with existing materials should be fully established. This must include long-term effects, so that undesirable side effects are avoided.

Guidelines

A combination of both scientific and cultural knowledge and experience is indispensable for the study of all architectural heritage. The purpose of all studies, research and interventions is to safeguard the cultural and historical value of the building as a whole and structural engineering is the scientific support necessary to obtain this result. The evaluation of a building frequently requires a holistic approach considering the building as a whole rather than just the assessment of individual elements.

The investigation of the structure requires an interdisciplinary approach that goes beyond simple technical considerations because historical research can discover phenomena involving structural behaviour while historical questions may be answered by considering structural behaviour. Knowledge of the structure requires information on its conception, on its constructional techniques, on the processes of decay and damage, on changes that have been made and finally on its present state.

In general the process towards the definition of remedial measures should include the following steps:

- Acquisition of data: Information and investigation;
- Historical, structural and architectural investigations;
- Survey of the structure;

- Field research and laboratory testing;
- Monitoring.

Diagnosis and safety evaluation of the structure are two consecutive and related stages on the basis of which the effective need for and extent of treatment measures are determined. If these stages are performed incorrectly, the resulting decisions will be arbitrary: poor judgement may result in either conservative and therefore heavy-handed conservation measures or inadequate safety levels.

Evaluation of the safety of the building should be based on both qualitative (as documentation, observation, etc.) and quantitative (as experimental, mathematical, etc.) methods that take into account the effect of the phenomena on structural behaviour. Any assessment of safety is seriously affected by the uncertainty attached to data (actions, resistance, deformations, etc.), laws, models, assumptions, etc. used in the research, and by the difficulty of representing real phenomena in a precise way.

Case studies

In this section selected case studies are presented in order to illustrate the engineering application of the concepts addressed before. This is always a difficult task and, even when an adequate diagnosis has been carried out, it is often necessary to adjust the initial design according to unexpected findings.

The case studies are at different levels of remedial measures. In the first case study (Church of Saint Christ in Outeiro), the works have been completed. In the second case study, the works are to be initiated in the coming months (Monastery of Salzedas). Finally, in the last case study (Monastery of Jerónimos in Lisbon), an iterative diagnosis procedure is under way.

Church of Saint Christ in Outeiro

The church of Saint Christ in Outeiro (Bragança), in the North of Portugal, was built in 1698-1738. The structure is mostly made of local shale stone and thick lime mortar (rubble masonry), even if regular masonry (granite ashlar and dry / thin joints) was used in doors / windows frames and the façade. For a complete report on this structure please refer to Lourenço et al. (1999).

The structure is of moderate size ($38 \times 22 \text{ m}^2$ for the plan view, 13 m height for the nave and 22 m height for the towers), see Figure 2. The façade is a piece of large architectural value due to the false twin arch and the cladding in granite. It possesses a large opening and a balustrade that connects the towers. The side view shows framed galleries, forming three chapels. The interior of the church has a single nave (Latin cross) with crossed vaults, split in three parts by two arches. The arches are supported by the side walls and the transversal walls that divide the chapels, acting as buttresses.

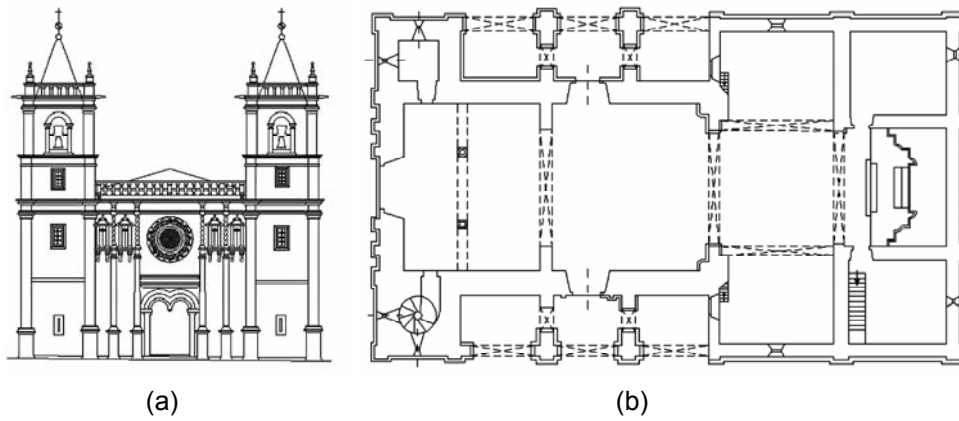

Figure 2 - Geometry of Saint Christ church: (a) front view and (b) plan section

The damage of the structure is localized in the main façade and in the choir. Some additional minor cracking visible in other areas of the structure did not seem alarming. The façade features large movements, vertically, in the vicinity of the twin arch, and horizontally, towards the outside, around the opening and at the top central part, see Figure 3a. The interior face of the wall does not show any sign of horizontal displacements and, with the use of a boroscope it was possible to check that the wall is made of two leaves, separated by approximately 0.10 m in the vicinity of the opening. The choir features heavy cracking of the arches and vaults, see Figure 3b. It is separated from the façade, except in the brackets, and the columns are out of plumb 2.6% (around 0.08 m).

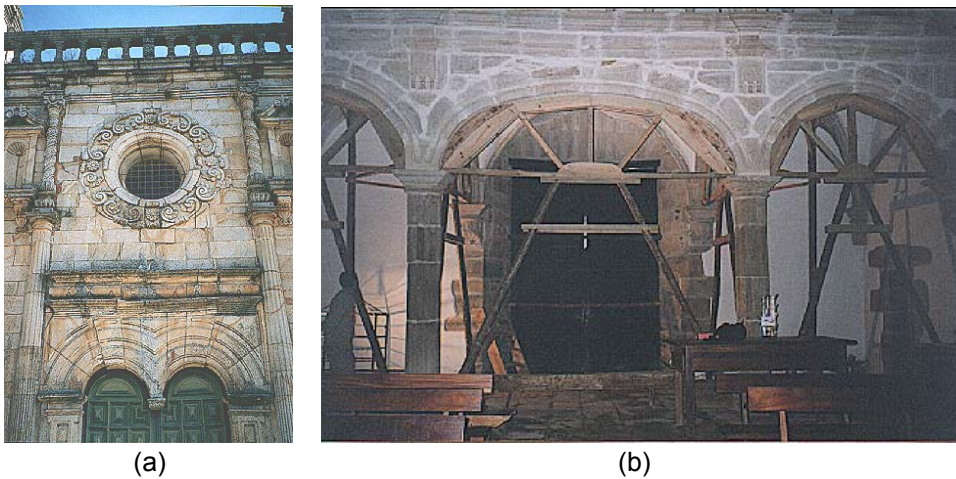

Figure 3 - Aspect of Saint Christ church before the remedial measures: (a) damage in the façade and (b) temporary support of the choir

Structural Analysis

For the analysis of the façade subjected to vertical loading a plane stress representation of the façade has been adopted. The thickness of the façade took into account the three-dimensional shape of the structure. The adopted elastic values were representative of the type of masonry found in the structure. The vertical loads considered in the analysis included the self-weight of the structure, the weight of the pyramidal roof of the bell-towers and the weight of the main nave roof. The soil-structure interaction has been modelled by interface elements, with properties obtained from in-situ testing of the soil.

The results of the analysis, assuming linear elastic behaviour of the material, are given in Figure 4a, in terms of maximum principal stresses. Under the most unfavourable hypothesis that all permanent loads are applied simultaneously and not in agreement with the construction phases, it is observed that the maximum value of the tensile stresses and the compressive stresses are extremely low, respectively +0.11 (tension) and -0.54 (compression) N/mm². This analysis demonstrates that, under the assumption of a homogeneous material for the façade, the structure should not present any damage due to vertical loading. For this reason, the analysis of the structure under combined actions (vertical and horizontal) seemed necessary.

For this analysis, the model of the previous section was adopted but the plane stress elements have been replaced by shell elements. For the purpose of horizontal loading, it was assumed that the walls normal to the façade would act as shear walls, preventing any horizontal movement in this direction. To assess the behaviour of the structure under earthquakes, a simplified approach was used by replacing the seismic action by a set of equivalent horizontal loading. According to the Portuguese Code, the horizontal loading is given by 6.6% of the mass, for this particular region in Portugal. Assuming that the top of the façade is capable of moving freely and adopting linear elastic behaviour for the material, the results of the analysis are given in Figure 4b, in terms of maximum principal stresses. It can be observed that the maximum value of the tensile stresses and the compressive stresses are still extremely low, respectively +0.12 (tension) and -0.51 (compression) N/mm².

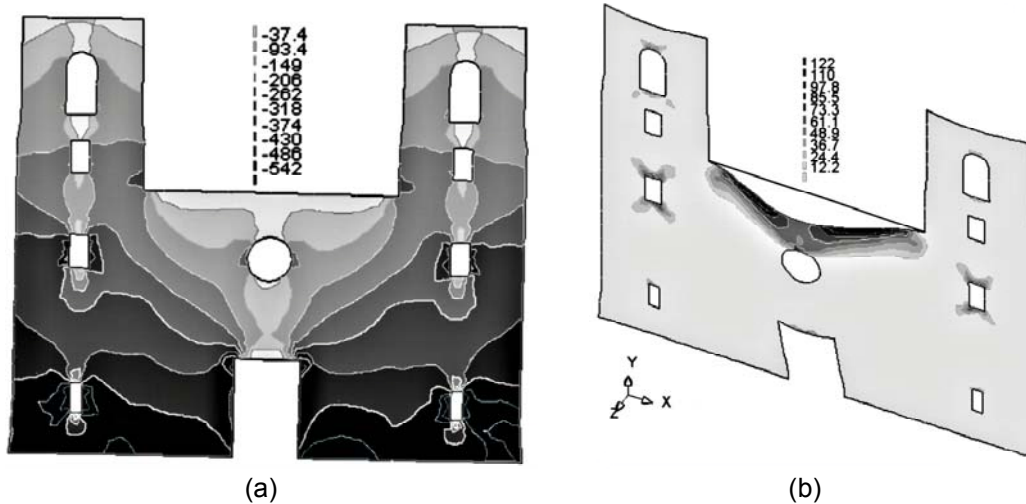

Figure 4 - Results of the structural analysis for Saint Christ church in terms of maximum principal stresses ($\times 10^{-3}$ N/mm³) on the deformed homogeneous structure: (a) plane stress analysis; (b) shell analysis.

From these results it was concluded that the assumption of a homogeneous material is incapable of justifying the damage exhibited by the structure, even with the action of the horizontal forces equivalent to the seismic load. For the purpose of a non-linear dynamic analysis, the wall was modelled with two different leaves: granite ashlar with an average thickness of 0.30 m and shale masonry with an average thickness of 1.20 m, with their respective elastic properties.

Raleigh damping was assumed, the usual damping coefficient ξ equal to 5% was adopted and a base acceleration was generated according to the Portuguese Code. As the dynamic properties of the two leaves differ substantially, separation of the leaves will occur. Figure 5 presents some examples of the deformed structure throughout time. It was possible to obtain different configurations of separation between the two leaves (in the top and centre of the wall). For example, Figure 5a shows the walls moving in opposite directions and Figure 5b shows the walls moving in the same direction, with small separation at the top and large separation around the opening. This last form of separation seems to be in good agreement with the damage exhibited by the façade.

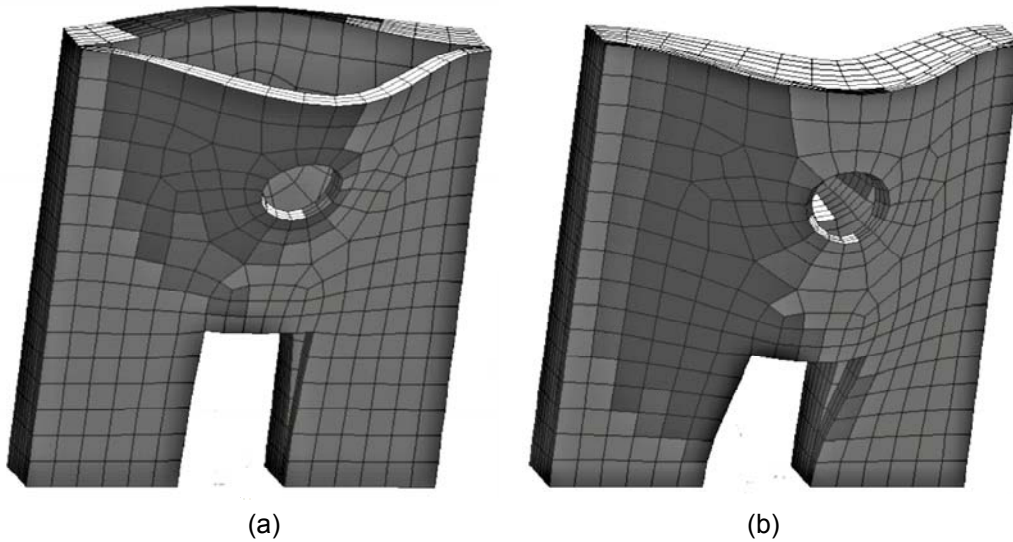

Figure 5 - Deformed meshes for heterogeneous non-linear dynamic contact analysis at different time steps, for Saint Christ church.

An independent structural analysis of the choir was also carried out and again demonstrated that the vertical load thrust is deficiently absorbed by the columns and a connection between the side walls and the vault is missing, meaning that the original conception of the choir is incorrect.

Remedial measures

The conclusions of the numerical analyses of interest for the definition of the intervention are that (a) the damage was due to seismic action and (b) there were two misconceptions in the construction of the church (façade and choir). Therefore, it is only necessary to correct these errors with proper façade wall tying and adequate connection between the choir and the external walls.

Keeping these conclusions in mind, remedial measures were proposed to ensure proper monolithic behaviour between the choir and the external walls, and to connect the external leave to the inner leave. This was achieved with ties inside the vault filling, for architectural reasons. It is noted that the selection of materials was careful, including the use of stainless steel, special mortars and non-intrusive grouting anchors (with sleeve). Figure 6 illustrates different aspects of the works.

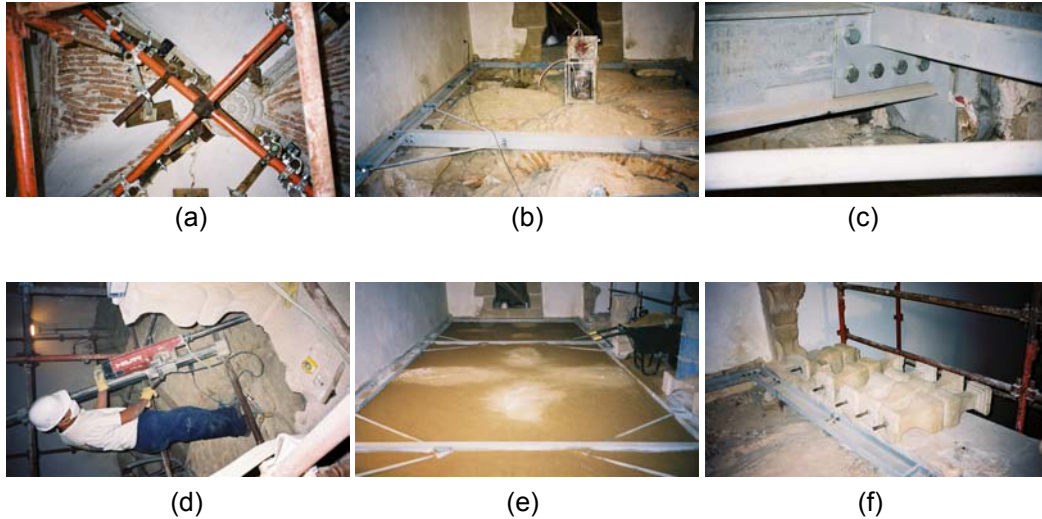

Figure 6 - Details of the works carried out, for Saint Christ church.

Monastery of Salzedas

The Monastery and Church of Salzedas are located in Salzedas, Tarouca and the church was recently classified as National Portuguese Monument. The church is essentially set in an urban environment, whereas the monastery is set in a more rural environment. The plan dimensions are large, $75 \times 101 \text{ m}^2$, making it the second largest church in Portugal, after the World Heritage Monument – Monastery of Alcobaça. The monastery and church possess a longitudinal irregular plan with different volumes, typical of a Cistercian Abbey. The present study focus exclusively in the cloister dated from the 17th century.

The condition of the cloister is quite poor, including biological colonization sometimes associated with moisture stains, deterioration of the bricks in the vaults, cracks with variable thickness, crushing of stones and excessive movements in walls and vaults. Details about this case study can be found in Lourenço et al. (2001).

The largest and widest set of cracks occurs in the barrel vaults of the 2nd level, as well as in two corners. The cracks occur mostly in the longitudinal direction, even if some transversal cracks also occur, up to a crack opening of 40 mm. The vaults of the first level exhibit also cracks, up to a crack opening of 15 mm. One wing is supported on temporary wooden poles. The walls exhibit widespread cracking at the 2nd level and almost no cracking at the 1st level. With the exception of a few localized areas, cracking is minor (crack openings in the range of 1 to 5 mm). Vertical displacements up to 35 mm were measured at the key of the crossed vaults of the 1st level. But all the walls of the cloisters exhibit large horizontal movements that lead to the separation between the vaults and the walls, in a clear lack of verticality. The out-of-plumb displacement of the internal walls reaches values of up to 0.18 m. Several brackets supporting the crossed vaults of the first level show signs of compressive crushing. The tilting movement of the walls can explain

this. The absence of connection between the infill of the crossed vaults and the walls resulted in a very localized area to transfer the load, i.e. only the brackets. Also, a significant number of bricks show deterioration, particularly around the cracked areas. This occurs in both levels and can be explained by frost-thaw cycles and water infiltration, as the amount of rainfall per year in the region is high and the temperatures in the winter are excellent for ice formation (daily cycles with $\pm 0^\circ$). Other perturbing signs, less relevant from the structural point of view, include damage of the stone due to freeze-thaw cycles and overall biological colonization. Figure 7 details typical observed damage.

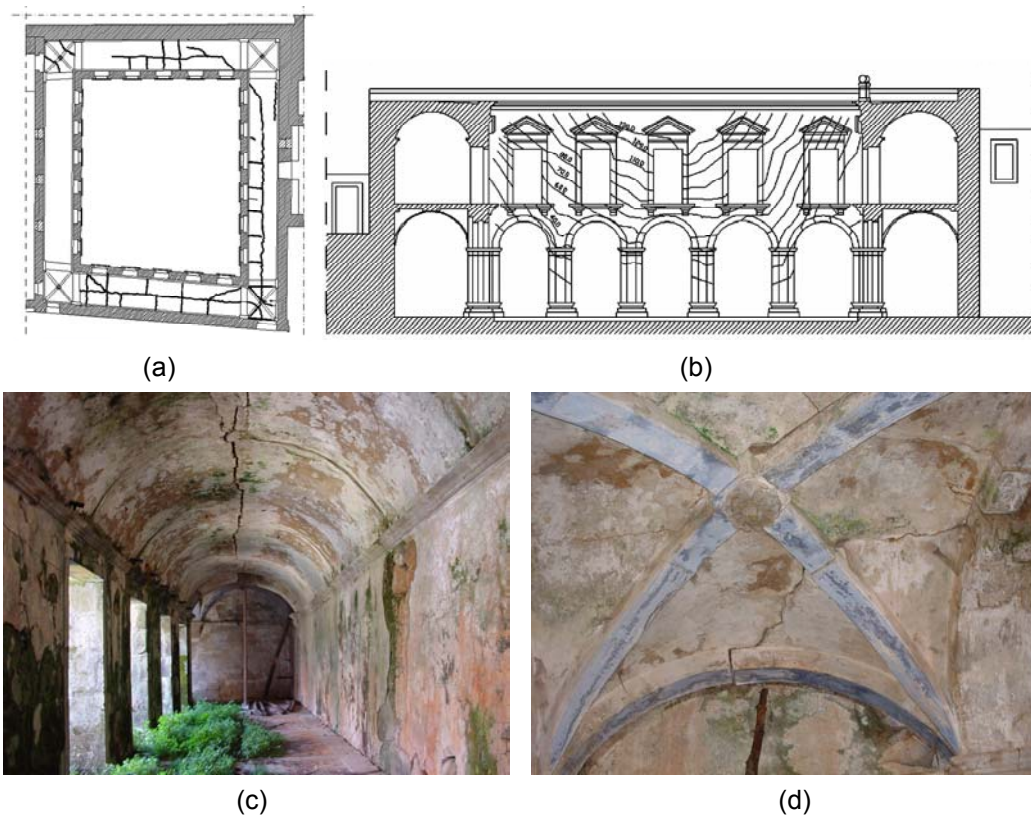

Figure 7 - Damage in the Salzedas' cloister: (a) mapping of cracks in the 2nd level; (b) out-of-plane displacements of an internal wall; (c) aspect of vault in the 2nd level; (d) aspect of corner in the 2nd level.

Inspection and Diagnosis

In order to characterize the cloister, to justify the observed damage and to define corrective measures, an experimental in-situ and laboratory testing program was carried out. This included a soil and foundation survey, visual inspection with the aid of an endoscope, flat-jack testing, coring, and chemical, physical and mechanical

characterization of materials. A numerical analysis of the structure allowed to discuss its safety and to better understand the causes of damage.

The conclusions of the study were that: (a) the non-symmetry between the internal and external walls of the cloister result in movements in the direction of the court, as observed in the construction; (b) a linear elastic analysis of the construction results in very limited displacements (in the order of the millimeter) and moderate stress values (maximum tensile stress of +0.25 MPa and maximum compressive stress of -0.6 MPa). The large displacements observed in the construction require a geometrical and physical non-linear analysis; (c) in order to obtain horizontal displacements in the order of the observed in the structure, it is necessary to consider the soil-structure interaction. It seems therefore that the foundations play a key-role in the observed damage; (d) the high movements recorded in the construction and the deterioration of the brick vaults indicate that the safety level of the structure is not compatible with any use and remedial measures are necessary.

Remedial measures

The following measures will be undertaken: adjustable propping; removal of vaults infill (1 + 0.5 wings); elevation of the vaults (1 + 0.5 wings). Restoring the verticality of one inner wall and one corner; replacement of fractured brackets; relocation of the key stones and joints filling; placement of ties and strengthening with CFRP (1 + 2 x 0.5 wings); refill vaults with selected silty soil; water-proofing and drainage of the terrace; repointing of joints in walls; temporary closure of the openings.

Monastery of Jerónimos

Monastery of Jerónimos is, probably, the crown asset of Portuguese architectural heritage dating from the 16th century. The monumental compound has considerable dimensions in plan, more than $300 \times 50 \text{ m}^2$, and an average height of 20 m (50 m in the towers). The monastery evolves around two courts. The construction resisted well to the earthquake of November 1, 1755. Later, in December 1756, a new earthquake collapsed one column of the church that supported the vaults of the nave and resulted in partial ruin of the nave. In this occasion also the vault of the high choir of the church partially collapsed.

For the purpose of assessing the safety of the Church of Monastery of Jerónimos under vertical loading, two finite element models have been developed for the nave and the transept. A preliminary in situ investigation has also been carried out including geometrical survey, visual inspection, ultrasonic testing and radar testing. Full details are given in Lourenço and Krakowiak (2003).

The church has considerable dimensions, namely a length of 70 m, a width of 40 m and a height of 24 m, see Figure 8a. The nave is divided by two rows of columns, with a free height of around 16.0 m. Each column possesses large bases and fan capitals. The transverse sections of the octagonal columns have a radius of 1.04 m (nave) and 1.88 m (nave-transept). The columns seem to be made of a single block or two blocks, for the nave, and four blocks, for the transept. The vaults are ribbed and are connected to the columns by the large fan capitals. Cross section of the nave vault is, mostly, a slightly

curved barrel vault, even if sup-ported at the columns. Thin stone slabs are placed on top of the stone ribs. On top of the slabs, a variable thickness mortar layer exists. The part of the slab inside the capital is filled with a concrete-like material with stones and clay mortar. On top of the vaults, brick masonry wallets were built during the 1930's to provide support for the roofing tiles.

The adopted model for the main nave includes the structural detail representative of the vault and more unfavorable, see Figure 8b. Appropriate symmetry boundary conditions have been incorporated. The model includes three-dimensional volume elements, for the ribs and columns, and curved shell elements, for the infill and stones slabs. The external (south) wall was represented by beam elements, properly tied to the volume elements. The supports are fully restrained, being rotations possible given the non-linear material behavior assumed. All elements have quadratic interpolation, resulting in a mesh with 33335 degrees of freedom. The deformed mesh at failure indicates that the structural behavior is similar to a two-dimensional frame, with a collapse mechanism of five hinges (four hinges at the top and base of the columns and one at the key of the vault).

Given the complexity of the vault and the time consumed in the model of the nave, a simplified two-dimensional model of these arches was adopted for the structural analysis. Figure 8c illustrates the conservative adopted model, which includes the arch, the infill, the nave column and the external wall, with appropriate stiffness values and boundary conditions. All elements have quadratic interpolation, resulting in a mesh with 3530 degrees of freedom. Again, the actions considered in the analysis include only the self-weight of the structure. Collapse occurs with a typical four hinges mechanism, being three hinges located in the vault and one hinge located in the right support.

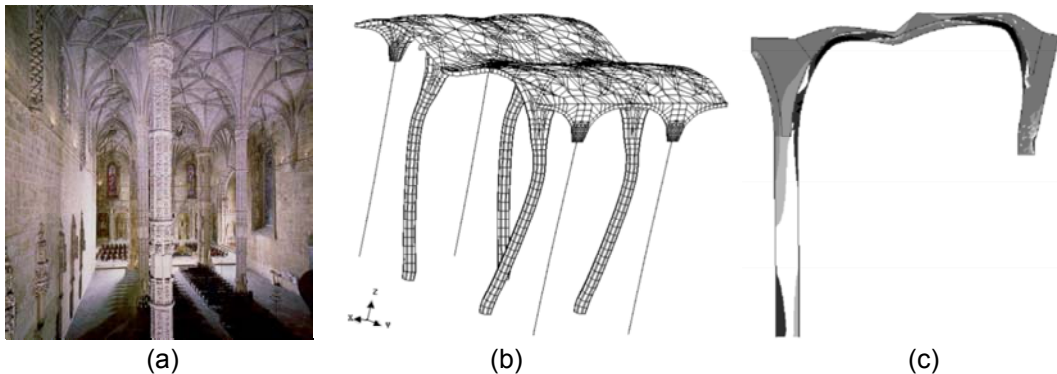

Figure 8 – Monastery of Jerónimos: (a) aspect of the nave; (b) model of the nave; (c) model of the transept.

The analysis carried out allowed to conclude that: (a) collapse of the nave occurs with a failure mechanism involving the columns and the vault; (b) collapse of the transept occurs with a failure mechanism involving the external walls and the vault; (c) the compressive strength of masonry is a key factor for the response; (d) the safety of the

structure seems low, when compared with similar constructions; (e) the columns of the nave are rather slender. It is stressed that the Church has been in use for some hundred years with moderate damaged ribs, and moderate tilting of the columns and sidewalls. Given the cultural importance of the construction, the safety of the users, the seismic risk and the accumulation of physical, chemical and mechanical damage, complementary NDT was proposed. The analyses carried out and the new proposed NDT results are fundamental for the definition of further action and the possible implementation of a monitoring program.

Conclusions

Conservation, analysis, understanding and strengthening of ancient structures remain a true challenge from the engineering point view, despite the considerable investment in research and development in the last decades.

Recommendations are currently available taking into consideration the expertise and diversity of different countries. Nevertheless, the application of the recommendations will always depend on the skills and experience of the practitioner. Examples of recent case studies in Portugal are provided here, to serve as a database of possible solutions and to act as guidelines for possible similar cases.

References

- Croci, G. 1998. *The conservation and structural restoration of architectural heritage*. Computational Mechanics Publications. Southampton.
- CUR 1997. *Structural masonry: An experimental/numerical basis for practical design rules*. Rots JG (ed). Balkema. Rotterdam.
- Giuffrè, A. 1993. *Safety and conservation of historical centers (in Italian)*. Editori Laterza. Bari.
- ICOMOS 2001. Recommendations for the analysis, conservation and structural restoration of architectural heritage.
- Lourenço, P.B., Oliveira, D.V., Mourão, S.C. 1999. *Stability study of the Church of Saint Christ in Outeiro* (in Portuguese). Report 99-DEC/E-2. University of Minho.
- Lourenço, P.B., Vasconcelos, G., Martins, J.B., Ramos, L., Jalali, S. 2000. *Diagnosis of the stability conditions of the XVII century cloister of the Monastery of Salzedas, in Tarouca* (in Portuguese). Report LEC 31/2000. University of Minho.
- Lourenço, P.B. 2002. Computations of historical masonry constructions, *Progress in Structural Engineering and Materials*, **4(3)**: 301-319.
- Lourenço, P.B., Krakowiak, K.J. 2003. Stability assessment of the vaults in the church of Monastery of Jerónimos. Report 03-DEC/E-02. University of Minho.
- Meli, R. 1998. *Structural engineering of historical buildings (in Spanish)*. Mexico-City. Fundación ICA.