

Test Method

# The use of a three-point support flexural test to predict the stiffness of anisotropic composite plates in bending

J.P. Nunes <sup>\*</sup>, A.S. Pouzada, C.A. Bernardo

*Department of Polymer Engineering, Universidade do Minho, 4800-058 Guimarães, Portugal*

Received 17 January 2001; accepted 20 March 2001

## Abstract

Anisotropic polymeric matrix composite discs supported on three points were subjected to a non-destructive bending test to study their behaviour in complex flexural loading situations. The results show that the flexural behaviour of the composites depends on several factors, such as fibre orientation, laminate stacking, surface waviness and moulding temperature. The experimental data were compared with those obtained from the finite element program software ALGOR. Differences up to 13% were found between the experimental and simulated values of the flexural stiffness. In spite of that, it was concluded that the non-destructive test used is a useful tool to predict the behaviour of anisotropic composites and to validate the results obtained from computer FEM analysis. © 2001 Elsevier Science Ltd. All rights reserved.

*Keywords:* Anisotropic composite plates; Flexural stiffness; Three-point bending test

## 1. Introduction

The flexural stiffness of anisotropic composite plates subject to pure bending in any direction is usually calculated using engineering constants that are directly derived from the laminate normalised flexural compliance matrix [1,2]. Depending on support conditions, complex states of stress may result on loaded composite plates and shells. Some of these bending stress states can be especially severe in the case of long fibre composites that have low stiffness across the fibre direction. Furthermore, as non-predictable multidirectional solicitations are generated in the plate, the overall flexural behaviour of this type of composite is difficult to predict using analytical methods. It is therefore important to envisage reliable methods to estimate that behaviour. It is also of importance to generate methods to evaluate optimal fibre

orientations and laminate stacking sequences that will help to produce better performing composites.

In this work, anisotropic discs of two different composite materials were loaded at the centre and subjected to three-point support bending tests to assess and compare their flexural stiffnesses. The discs were compression moulded at four different temperatures to investigate the influence of the processing temperature on the flexural behaviour. Then, in order to assess the influence of the fibre direction on the flexural stiffness, they were bent with the continuous fibre direction varying with respect to the position of the supports. Finally, the properties of the laminate plies were determined and used in the finite element software program ALGOR (Algor Inc., Pittsburgh, USA) to generate data for comparison with the experimental results. It was concluded that non-destructive bending tests are useful tools to predict the behaviour of anisotropic composites in complex bending situations and to optimise their design.

<sup>\*</sup> Corresponding author. Tel.: +351-253-510-245; fax: +351-253-510-249.

*E-mail address:* jpn@dep.uminho.pt (J.P. Nunes).

## 2. Theory

Bassalli [3] proposed an analytical solution to determine the vertical deflection,  $\delta$ , of an isotropic elastic disc loaded at the centre and supported at three points regularly distributed along its periphery

$$\delta = \frac{3F}{2\pi h^3} \frac{1-\nu^2}{E} R^2 B(\nu) \quad (1)$$

where  $B(\nu)$  is a function of the Poisson ratio,  $\nu$

$$B(\nu) = \frac{4}{(1-\nu)(3+\nu)} \left( 2 \ln 3 - \frac{\pi}{27}(1+\nu)(\pi+3\sqrt{3}) \right) + \frac{(\nu-1)^2}{2(3+\nu)(1+\nu)} \quad (2)$$

and the other variables are:  $F$ , applied load;  $R$ , radius of the circumference where the supports are located;  $E$ , elastic modulus; and  $h$ , disc thickness.

Although the *flexural stiffness* of the plate,  $C = E/(1-\nu)^2$ , depends explicitly on the Poisson ratio, the influence is minimal, as for most engineering materials  $\nu$  varies between 0.2 and 0.5. In this range, the value of  $B(\nu)$  varies between 1.66 and 1.72. In any case, the flexural stiffness of any material will be proportional to the value of the *force/displacement* slope,  $S_0$ , determined from three-point support flexural tests at small deflections. Thus, by making  $S_0 = F/\delta$ ,  $C$  can be directly derived as

$$C = \frac{3}{2\pi h^3} R^2 B(\nu) S_0 \quad (3)$$

In the actual testing, the Bassalli model is not applicable exactly, as the discs overhang from the supports. Pouzada et al. [4,5] developed experimentally a correction factor,  $S_p$ , for the force/displacement slope in Eq. (3). According to the authors, the slope in the experimental set-up is related to  $S_p$  by

$$S_p = \frac{S_0}{0.59(1 - e^{-4.1(\Delta R/2R)}) + 1} \quad (4)$$

where  $S_0$  is the slope of the force/displacement curve from the disc bending tests, and  $\Delta R$  the radial overhang (Fig. 1).

In this work, the assessment of the influence of the various parameters in the flexural behaviour was made in terms of a “reduced” flexural stiffness,  $C_R = C/B(\nu)$ , given by

$$C_R = \frac{3}{2\pi h^3} R^2 S_p \quad (5)$$

## 3. Experimental

### 3.1. Materials

A dry powder coating unit developed at the Clemson University (South Carolina, USA) [6–10] was used to fabricate unidirectional towpregs with 25% fibre volume content, from a polycarbonate powder (Bayer, Makrolon 2458) and PAN-based carbon fibres (Amoco, Thornel T300/12/NT).

A commercial sheet moulding compound (SMC; Menzolit, 28 LS 33745 202/11), based on unsaturated polyester reinforced with 30% (v/v) E-glass fibres, was used in the fabrication of the SMC/C-R discs. This material consists of two equal thickness layers with different fibre geometries, one with continuous fibres and the other with 25 mm long chopped strand fibres.

### 3.2. Sample preparation

Both C/PC and SMC/C-R plates were produced by hot compression moulding at four different temperatures using an 800 kN SATIM press.

Before compression moulding, a technique described elsewhere [10–12] was used to fabricate C/PC preforms from the towpregs. The preforms were placed into a 117 mm × 112 mm × 2 mm mould mounted in the press and pre-heated for 10 min at temperatures ranging from 220 to 280°C. The compression pressure was set at 8 MPa and maintained for 10 min. The mouldings were allowed to cool down to room temperature in the mould. Discs with a diameter of 105 mm were then cut from the C/PC plates for testing.

The SMC/C-R discs, 200 mm in diameter and 2.5 mm thick, were directly obtained from a pre-heated mould mounted between the platens of the press at temperatures ranging from 130 to 160°C. A pressure of 10 MPa was maintained for 3 min to allow the material to cure before opening the mould.

### 3.3. Three-point support bending tests

The rig for the three-point flexural test shown in Fig. 1 was mounted on an Instron 1122 testing machine with a 500 N load cell. The tests were carried at a crosshead speed of 1 mm/min, and the vertical displacement measured at the centre of the disc with a LVDT displacement transducer with an accuracy of 1  $\mu$ m.

At each moulding temperature, 12 SMC/C-R and 12 C/PC discs were tested with the three supports located at the perimeter of circumferences with diameters of 176 and 93.5 mm, respectively.

The anisotropy induced by the fibre orientation in the flexural stiffness was assessed for both composites. This was done by rotating the discs to obtain three different alignments of the unidirectional fibres in relation to the

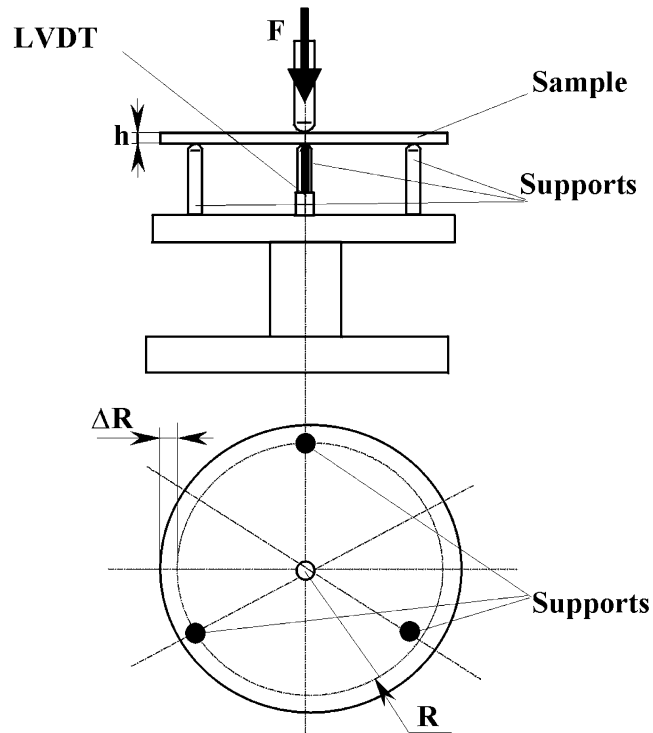

Fig. 1. Schematic diagram of the three-point support flexural test (from Ref. [4]).

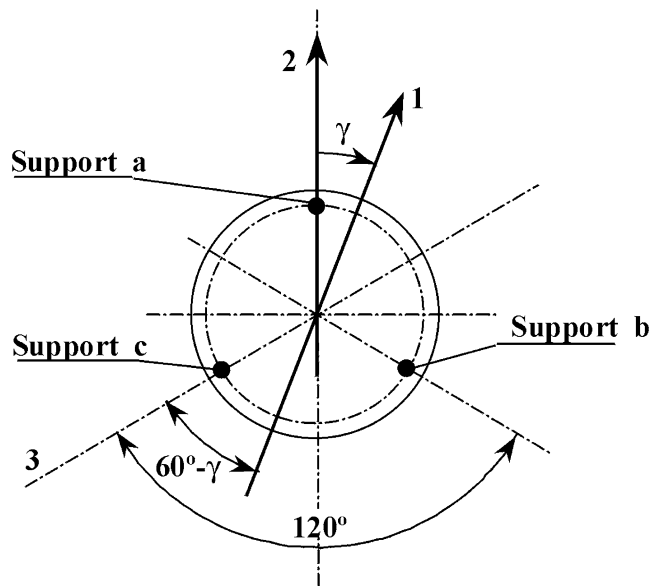

Fig. 2. Composite disc loading conditions: (1) fibre direction; (2) direction of reference.

position of the supports. As Fig. 2 shows, the fibres were aligned at angles,  $\gamma$ , of 0, 15 and 30° with respect to the radial position of one of the supports and the centre of the disc. Four discs were tested for each direction up to a deflection of approximately 2 mm to minimise the effect of the membrane stresses.

### 3.4. FEM simulations of composite discs flexure

The derivation of an analytical solution for the bending of a centrally loaded thin anisotropic disc supported at three points regularly distributed along the circumference is not practical. Therefore the prediction of the flexural performance was based in simulations made with the FEM software ALGOR.

Fig. 3 shows the finite element mesh for the SMC/C-R discs. The models for both composites consist of triangular elements with an aperture of 7.5° and a common vertex at the centre of the discs and quadrilateral elements elsewhere. A total number of 1004 and 480 elements were used in the definition of the SMC-R and the C/PC discs, respectively.

Three nodes located in circumferences at radial distances from the centre of 46.75 and 88 mm were used to define the supports in the C/PC and SMC/C-R discs, respectively. The vertical displacement ( $x$ -direction) was calculated for a load of 35 N applied vertically at the centre.

The composite material-type element was selected in the software to enter the elastic properties of the laminate plies shown in Table 1. For the C/PC composite, the properties were derived from micromechanical models [1,2,13] using the fibre volume content and the raw materials tensile properties. The tensile properties of the PAN carbon fibres were determined by single filament tests. In the case of the SMC/C-R composites, the properties of the plies were also derived from the fibre volume content, the raw materials and the composite tensile properties determined from ISO3268 tensile tests.

The C/PC laminate was composed by 20 0.1-mm thick

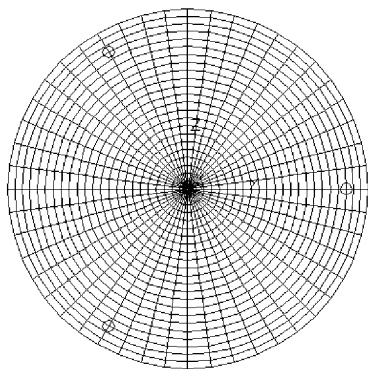

Fig. 3. FEM model to simulate the SMC/C-R disc bending.

Table 1  
In-plane elastic properties of the composite plies

Property	Units	SMC/C-R		
		C/PC	Unidirectional ply	Unidirectional ply
Longitudinal modulus ( $E_1$ )	GPa	51.80	29.60	8.87
Transverse modulus ( $E_2$ )	GPa	3.13	6.03	8.87
Shear modulus ( $G_{12}$ )	GPa	1.13	2.32	3.41
Poisson's ratio ( $\nu_{12}$ )	–	0.35	0.28	0.30

plies with properties as defined in Table 1. In the case of the SMC/C-R laminates, two types of plies, with a thickness of 1.25 mm, were considered. One, with the properties of the unidirectional ply presented in Table 1, was located at the top of the laminate with 0° orientation in relation to laminate reference. The other, with the properties of the randomly reinforced ply, was located at the bottom of the laminate.

## 4. Results and discussion

Fig. 4 shows a plot of the experimental results obtained for the flexural stiffness of the C/PC and SMC/C-R composites as a function of the fibre orientation angle,  $\gamma$ .

The SMC/C-R discs seem to benefit from the randomly fibre reinforced ply, as they have a higher and little varying flexural stiffness. On the other hand, the results were more dispersed, which is probably related to the higher surface waviness caused by shrinkage during cooling. In fact, in this work it was not possible to completely prevent warping of the SMC/C-R discs. In the case of the C/PC discs, the higher stiffness and lower coefficient of expansion of the carbon fibres led to improved dimensional stability and warping was not observed.

Fig. 4 also shows that the stiffness,  $C_R$ , increases with the fibre orientation angle,  $\gamma$ , up to 30° for both composites. Thus, considering the symmetry of the applied loading (Fig. 2), it is possible to infer that the disc stiffness is a periodic function of the angle  $\gamma$ . This means that both discs are expected to show maximum stiffness values in three-point bending tests when the continuous fibres are oriented at angles of  $\gamma=30\pm n\times 60^\circ$ ,  $n$  being an integer. This effect can be observed in Fig. 5 for the C/PC discs.

Figs. 6 and 7 show the influence of moulding tempera-

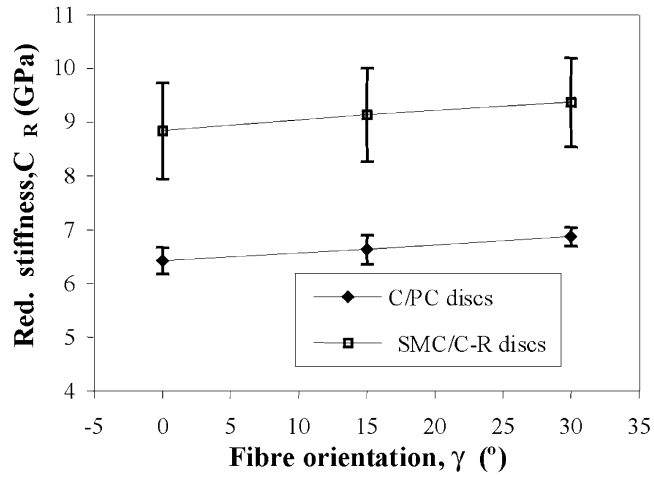

Fig. 4. Stiffness of the C/PC and SMC/C-R discs as a function of fibre orientation.

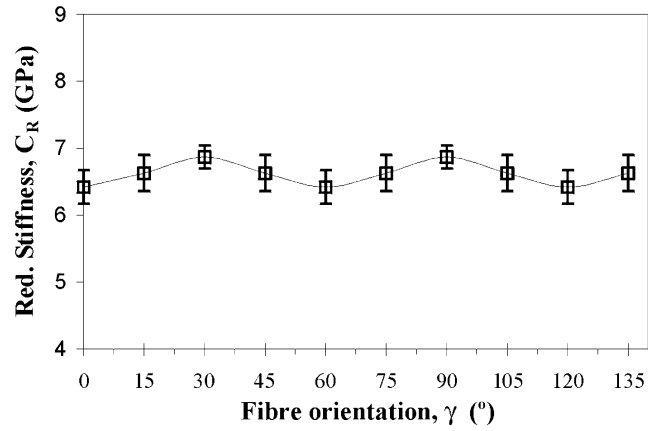

Fig. 5. Flexural stiffness of the C/PC discs as a function of the fibre orientation.

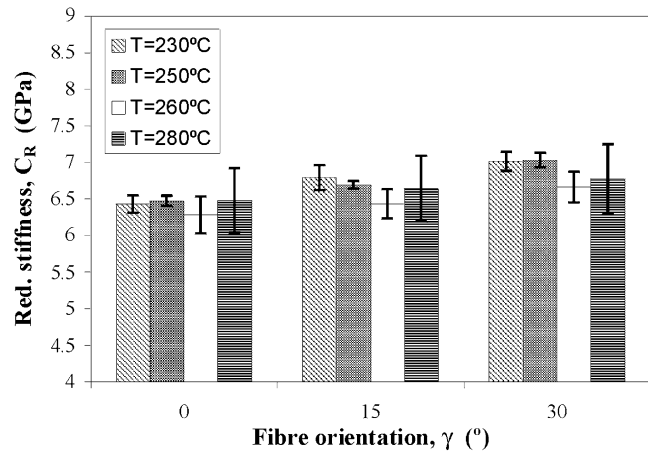

Fig. 6. Influence of the moulding temperature on the C/PC stiffness.

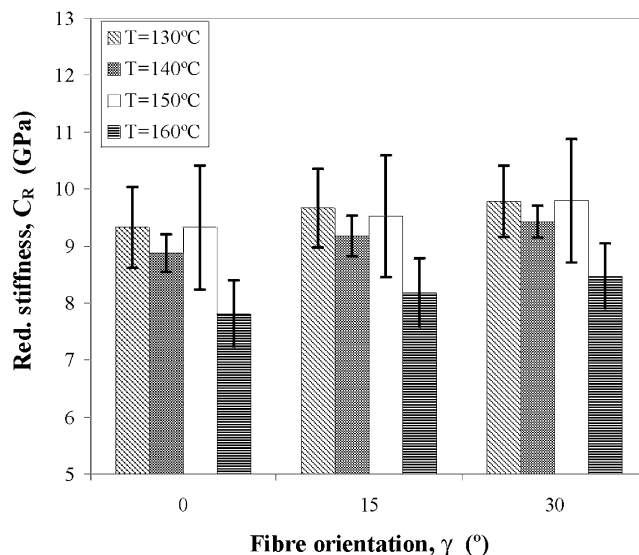

Fig. 7. Influence of the moulding temperature on the SMC/C-R disc stiffness.

ture on the flexural stiffness obtained in the C/PC and SMC/C-R discs, respectively.

As can be observed in Fig. 6, the moulding temperature does not influence significantly the flexural behaviour of the C/PC discs. In fact, the average result at each orientation falls inside the standard deviations of the values obtained at the different temperatures. These findings are in agreement with the nearly insensitive flexural behaviour of the polycarbonate mouldings with respect to the processing temperature [14]. Nevertheless, in the case of the SMC/C-R discs it was possible to notice a lower flexural performance when the compression moulding was done at  $160^\circ\text{C}$  (Fig. 7). This result is in agreement with the processing temperature range recommended by the SMC manufacturer ( $145\text{--}155^\circ\text{C}$ ), and is probably related with the voiding resulting from premature polyester cure at this temperature.

Finally, in Fig. 8, the flexural stiffness data of the C/PC and SMC/C-R discs are compared with those predicted upon using the software ALGOR. In both cases, the ALGOR simulations confirm the increase of the flexural stiffness with the fibre orientation,  $\gamma$ , between  $0$  and  $30^\circ$ . The FEM software is able to describe this trend but, as Fig. 8 also shows, for the C/PC discs the predictions are approximately 13% below the experimental data.

Three reasons may explain this difference. In the first place, the raw material data used to predict the ply properties used in the simulations are not accurate. Also, in the simulations the forces are applied at single points, which is not the case of the tests. Finally, and contrarily to the tests which are carried out in the deformation mode, the simulations consider the application of a static force.

In the case of the SMC/C-R discs, a better agreement was found between experimental and predicted stiffness results. In fact, as the variability of the experiments is larger, all the predicted values fall inside the standard deviation of the test data. However, it appears that the simulations under-predict the increment of stiffness with  $\gamma$ . This may derive from the theoretical assumption of complete isotropy in the randomly reinforced ply, which does not correspond exactly to the reality.

## 5. Conclusions

Because of the inherent anisotropy, the mechanical behaviour of moulded composites plates loaded in complex bending conditions is usually difficult to predict. In this work it was shown that non-destructive bending tests on three-point supported discs can adequately predict the influence of the fibre orientation and laminate stacking sequence on the flexural stiffness. The results obtained allow the conclusion that the use of randomly reinforced layers in the laminate increases the mechanical performance of composites subjected to multidirectional stresses and/or strains. The results also show that the tests are sensitive to the anisotropy induced by the fibre orientation in the flexural stiffness. It is possible to identify an optimal fibre orientation in relation to the position of the supports that maximizes the mechanical performance of the composites.

Finally, in spite of the differences between experimental and simulated values, it was concluded that the tests provide a quick validation of finite element programs, such as ALGOR. These programs can then be used to optimise the composite fibre orientation and laminate

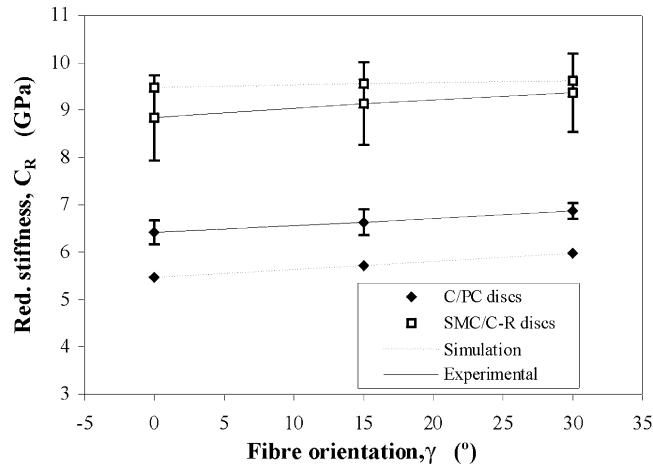

Fig. 8. Experimental and predicted data for the C/PC and SMC/C-R composites.

stacking sequence. However, the present work also showed that the flexural performance of moulded anisotropic composite plates cannot be completely predicted by FEM analysis. In fact, it depends on several factors that may not be determined ab initio, such as the processing temperature, surface waviness and loading conditions.

### Acknowledgements

The authors gratefully acknowledge the assistance of various research students at the Center for Advanced Engineering Fibers at Clemson University in the production of the towpregs. Special thanks are due to the *Fundação Luso Americana para o Desenvolvimento* (FLAD) for supporting the stay of J.P. Nunes in Clemson and the mobility of the researchers involved in the project.

### References

- [1] O. Saarela, LAMDA-LAMinate Design and Analysis, Helsinki University of Technology, Otaniemi, Finland, 1992.
- [2] S.W. Tsai, Composites design, Think Composites, USA, 1987.
- [3] W.A. Bassali, The transverse flexure of thin elastic discs supported at several points, Proc. Cambridge Phil. Soc. 53 (1957) 728–748.
- [4] A.S. Pouzada, A Study on the Design Data and Methods for Plate like Injection Moulded Thermoplastics Products, PhD thesis, Loughborough University of Technology, Loughborough, UK, 1982.
- [5] A.S. Pouzada, M.J. Stevens, Methods of generating flexure design data for injection moulded plates, Plast. Rubber Proc. Appl. 4 (1984) 181–187.
- [6] B.W. Gant, The Thermoplastic Coating of Carbon Fibers, MSc thesis, Clemson University, Clemson, USA, 1987.
- [7] B.W. Gant, D.D. Edie, G.C. Lickfield, M.J. Drews, M.S. Ellison, Thermoplastic coating of carbon fibers, ASTM STP 1004, 1989, pp. 50–61.
- [8] J.W. Klett, Towpreg Formation for Carbon/Carbon Composites, MSc thesis, Clemson University, Clemson, USA, 1991.
- [9] J.W. Klett, J. Albiger, D.D. Edie, G.C. Lickfield, Production and evaluation of a polyimide/carbon fiber powder-coated towpreg, in: Proceedings of the 7th International Conference on Carbon — Carbon'92, Essen, Germany, 1992, pp. 683–685.
- [10] J.P. Nunes, A Study of the Processing and Properties of Sheet Molding Compounds and Unidirectional Carbon Fibre Towpregs, PhD thesis, University of Minho, Guimarães, Portugal, 1998.
- [11] J.P. Nunes, D.D. Edie, C.A. Bernardo, A.S. Pouzada, Formation and characterization of carbon/polycarbonate towpregs, in: A. Poursartip, K.N. Street (Eds.), Proceedings of the 10th International Conference on Composite Materials — ICCM 10, Whistler, Canada, 1995, vol. III: Processing and Manufacturing, pp. 333–340.
- [12] J.P. Nunes, C.A. Bernardo, A.S. Pouzada, D.D. Edie, Formation and characterization of carbon/polycarbonate towpregs and composites, J. Compos. Mater. 31 (17) (1997) 1758–1777.
- [13] R.M. Jones, Mechanics of Composite Materials, Scripta Book Company, Washington, 1975.
- [14] N.M. Neves, Application of Subcomponents to the Design with Amorphous Thermoplastics, MSc thesis, University of Minho, Guimarães, Portugal, 1993.