



## UvA-DARE (Digital Academic Repository)

### An enhanced optical micro-fading device

Patin, G.; Erdmann, R.G.; Ligterink, F.; Neevel, J.G.; van den Berg, K.J.; Hendriks, E.

**DOI**

[10.1016/j.culher.2022.08.012](https://doi.org/10.1016/j.culher.2022.08.012)

**Publication date**

2022

**Document Version**

Final published version

**Published in**

Journal of Cultural Heritage

**License**

CC BY

[Link to publication](#)

**Citation for published version (APA):**

Patin, G., Erdmann, R. G., Ligterink, F., Neevel, J. G., van den Berg, K. J., & Hendriks, E. (2022). An enhanced optical micro-fading device. *Journal of Cultural Heritage*, 57, 276-285. <https://doi.org/10.1016/j.culher.2022.08.012>

**General rights**

It is not permitted to download or to forward/distribute the text or part of it without the consent of the author(s) and/or copyright holder(s), other than for strictly personal, individual use, unless the work is under an open content license (like Creative Commons).

**Disclaimer/Complaints regulations**

If you believe that digital publication of certain material infringes any of your rights or (privacy) interests, please let the Library know, stating your reasons. In case of a legitimate complaint, the Library will make the material inaccessible and/or remove it from the website. Please Ask the Library: <https://uba.uva.nl/en/contact>, or a letter to: Library of the University of Amsterdam, Secretariat, Singel 425, 1012 WP Amsterdam, The Netherlands. You will be contacted as soon as possible.

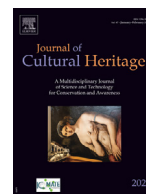

## Original article

## An enhanced optical micro-fading device

Gauthier Patin<sup>a,b,\*</sup>, Robert G. Erdmann<sup>b,c,d</sup>, Frank Ligterink<sup>e</sup>, Johan G. Neevel<sup>e</sup>,  
Klaas Jan van den Berg<sup>b,e</sup>, Ella Hendriks<sup>b</sup>

<sup>a</sup> Conservation Department, Van Gogh Museum, the Netherlands

<sup>b</sup> Department of Art and Culture, Programme for the Conservation and Restoration of Cultural Heritage, University of Amsterdam, the Netherlands

<sup>c</sup> Conservation Department, Rijksmuseum, the Netherlands

<sup>d</sup> Institute of Physics, University of Amsterdam, the Netherlands

<sup>e</sup> Cultural Heritage Agency of the Netherlands (RCE), the Netherlands

## ARTICLE INFO

## Article history:

Received 17 January 2022

Accepted 29 August 2022

Available online 23 September 2022

## Keywords:

Micro-fadeometry

Colour change

UV-VIS diffuse reflectance spectroscopy

Microscopy

Blue wool standards

## ABSTRACT

This paper introduces a new set-up for the determination of colour change on cultural heritage objects, referred to herein as a stereo-microfading tester. The system uses high quality optics through the implementation of a stereo-microscope as its central element. This technology enables new developments such as incorporation of high quality imaging systems, and separation of fading and colour measurement processes. This paper describes this new micro-fading set-up and evaluates its performance against traditional devices based on the measurement of blue wool standards. The results show a correlation between the fading performance obtained on different devices while highlighting a significant variability inherent to the blue wool samples

© 2022 The Author(s). Published by Elsevier Masson SAS.

This is an open access article under the CC BY license (<http://creativecommons.org/licenses/by/4.0/>)

## Data repository

The data and the figures related to this article have been stored on Zenodo and a DOI have been created (10.5281/zenodo.7017400).

## 1. Introduction

The topic of light-induced colour change has been extensively studied in recent decades in order to support decision making concerning the conservation and display of cultural heritage objects. More specifically, standard protocols for evaluating light fastness properties have been developed [1,2] as well as practical solutions, such as lighting policies and guidelines, for collection keepers [3–7]. However, a number of these decisions are often taken on the basis of partial, or sometimes inaccurate information. In the worst case, misinformed decisions can irreversibly impact the physical properties and values of the objects concerned [8]. For example, light sensitive items can undergo permanent colour changes in-

duced by optical radiation, which are usually considered as damage and associated with a loss of value for the object. The unique nature of works of art implies that light sensitivity assessment can either be estimated by performing tests on mock-up materials as similar as possible to the original objects or by assessing the original objects on tiny spots. In the last decade of the 20th century, two teams of researchers developed parallel devices that enable light-fastness assessment on a micro-scale [9,10], which led to the implementation of a commercially available micro-fading tester (MFT) commonly known as *Oriel-MFT* [11].

This article introduces a new MFT set-up recently developed at the Cultural Heritage Agency of the Netherlands<sup>1</sup> and provides a description and a comparison of its fading abilities against data reported in the literature. This new device, designated as *stereo-MFT*<sup>2</sup>, gives researchers more options for deeper analyses of color change phenomena. The idea is to extend the use of micro-fadeometry beyond conservation purposes, also using it for wider research on colour change phenomena.

\* Corresponding author at: Conservation Department, Van Gogh Museum, the Netherlands.

E-mail address: [g.patin@monemail.com](mailto:g.patin@monemail.com) (G. Patin).

<sup>1</sup> Rijksdienst voor het Cultureel Erfgoed (RCE) in Dutch. The instrument was developed in the Amsterdam site : Atelier Gebouw, Hobbemastraat 22, 1071 ZC, Amsterdam.

<sup>2</sup> A video that describes the stereo-MFT has been made and is available via the following link: <https://microfadingphd.wordpress.com/projects/>

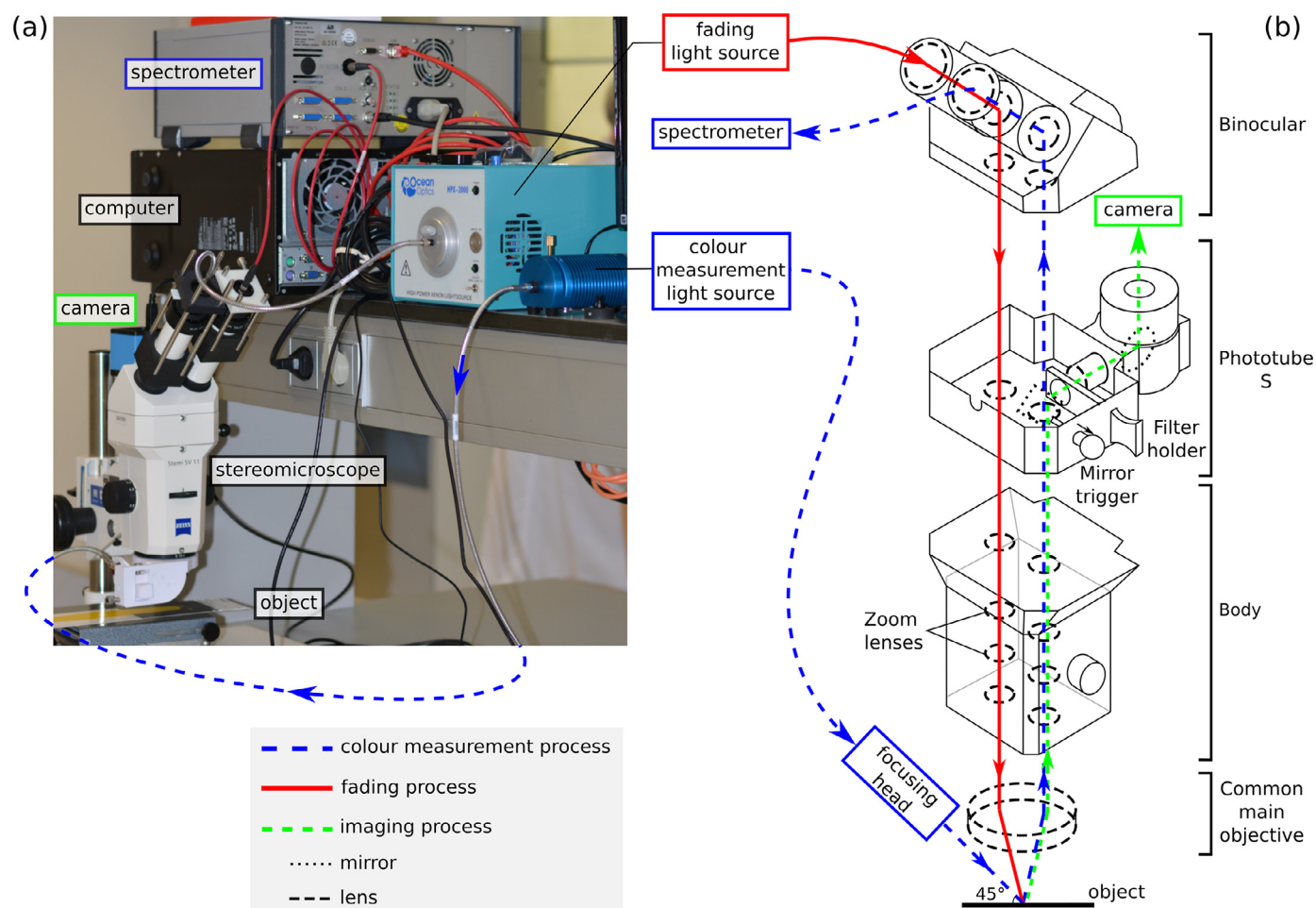

Fig. 1. Description of the stereo-MFT in the co-axial mode: photograph (a); 3D representation (b).

## 2. Research aim

Over the last two decades, the field of micro-fadeometry has developed rapidly; many institutions acquired micro-fading instrumentation<sup>3</sup> and new set-ups have emerged [12–14]. The technique has successfully proved its ability to identify light sensitive materials and classify them according to a reference scale currently based on blue wool standards (DIN EN ISO 105-B02 [15]) [16]. Nevertheless, most micro-fading devices have been designed with the idea to keep the instrument simple and economical<sup>4</sup>, which make devices easier to use and more accessible. However, the simplicity of the system restrains the data interpretation to relative ranking methodology. In other words, the technique can rank the light sensitivity of materials according to a defined scale - such as the ISO scale [1] - but any further interpretation is limited.

The development of micro-fadeometry involves deeper and wider interpretation of data, achieved through mathematical models of colour change [17,18]. Such models require a good understanding of which factors influence colour change, which is why the possibility to perform dose-response micro-fading analyses is critical for the development of the technique. Just like every artifi-

cially accelerated technique, micro-fadeometry is subject to failure of the reciprocity principle [19] which complicates the interpretation of dose-response data. On the practical level, the current approach to overcome this issue relies on the use of blue wool standards (BWS). A more fundamental approach implies a better understanding of the phenomena in place which requires a high level of control over the experimental parameters. Thus the long-term objective of this project aims to provide a research tool for scientists in order to improve our knowledge on accelerated light ageing experiments. As a first step, the implementation of the stereo-MFT is an attempt to develop technical and methodological tools that can monitor colour change as a function of energy in a repeatable and reproducible way.

## 3. Materials and methods

### 3.1. Description of the device

The central element of this new device is a stereomicroscope<sup>5</sup> [20] through which three main processes occur: fading, colour measurement and imaging (Fig. 1). The set-up comprises four types of components - light sources, detectors, optics, and connectors - where 3D printed technology has been used to manufacture the required connecting pieces with the help of an open-source

<sup>3</sup> A recent survey undertaken at the Getty Conservation Institute under the leadership of Vincent Beltran identified 74 cultural heritage institutions that currently possess a micro-fading device [34].

<sup>4</sup> Though micro-fading devices are usually cheaper than other analytical devices, human costs to perform analyses and interpret the data are often too high for small and medium institutions.

<sup>5</sup> The idea of incorporating a microscope in micro-fading systems was first implemented around 2011 at the Centre de Recherche sur la Conservation des Collections by Bertrand Lavédrine [35].

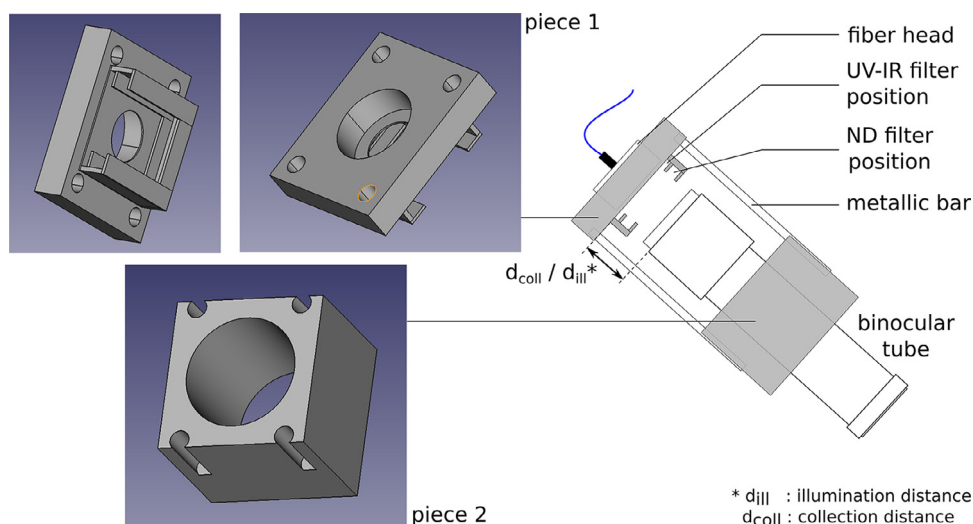

Fig. 2. Description of the 3D prints used for the binocular tubes.

Table 1  
Components of the stereo-MFT\*.

	PROCESSES		
	Colour measurement	Fading	Imaging
<b>Light source</b>	Halogen	(1) High power xenon (HPX) (2) Warm white LED	Halogen
<b>Detector Connector</b>	Spectrometer Optical fibres and 3D prints	Power metre	Microscope camera Lens tubes and 3D prints
<b>Optics</b>	Stereomicroscope and Focusing head		

\* Detailed information about each component is provided in S.I. n°02.

software called *FreeCad* [36] (Table 1 and Fig. 2)<sup>6</sup>. Figs. 1 and 4 illustrate the set-up with 3D and 2D schematic representations respectively.

Most micro-fading devices have been created using a 0°:45° geometry, where the fading (first value) happens vertically, and the colour measurement (second value) is performed at a 45° angle. With this new set-up, the user can choose between two different geometries. Indeed, in addition to the “traditional” 0°:45° geometry, the system can be modified in order to perform measurements with a 0°:(45°:0°) geometry, which we refer to as *co-axial* geometry. The term *co-axial* indicates that the fading light source and the spectrometer are both situated on a vertical axis above the sample. To switch from one geometry to another, only the position of the spectrometer has to be changed. In the co-axial mode (Fig. 4, (a)), it is connected to the right binocular of the stereomicroscope, while in the traditional configuration (Fig. 4, (b)) it is attached to the focusing head. In both cases, the fading light source remains in the same position: it is connected to the left binocular of the stereomicroscope by an optical fibre. However, due to the optics of the stereomicroscope, the fading beam does not quite fall perpendicular to the object's surface but at a small angle to the normal. This however, was found to have a negligible impact on the colour measurement. The position of the camera also does not change from one geometry to another as it remains connected to the phototube S.

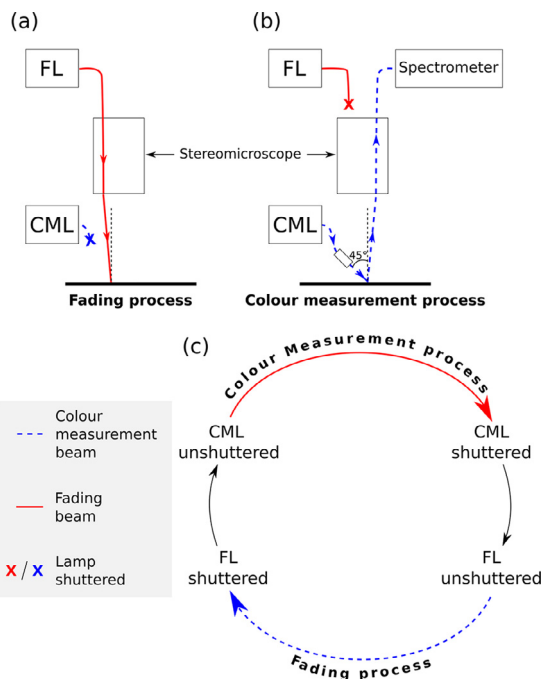

Fig. 3. Processes performed during a micro-fading analysis with the co-axial mode: Schematic representation (a & b); cycle of actions (c).

On the technical side, the stereo-MFT was created such that most elements can easily be accessed or replaced. The device was built to increase modularity which can be achieved by separating the fading and the colour measurement processes. The lack of interdependence between the two processes enables the user to modify one without influencing the other. First of all, it means that colour measurements can be performed on the object without having to fade it<sup>7</sup>, but it also opens new possibilities for research. For example, one could experiment with the shutter of the fading light source in order to investigate colour reversion phenomena. Or the use of different light sources for fading could be compared as well as the use of various types of incident radiation to

<sup>7</sup> In the current version of the set-up, comparison of colour measurements at different moments cannot be done with a high level of precision since it is not possible to find the exact same spot on the object once the latter moved.

<sup>6</sup> A description of each 3D print is given in S.I. n°01.

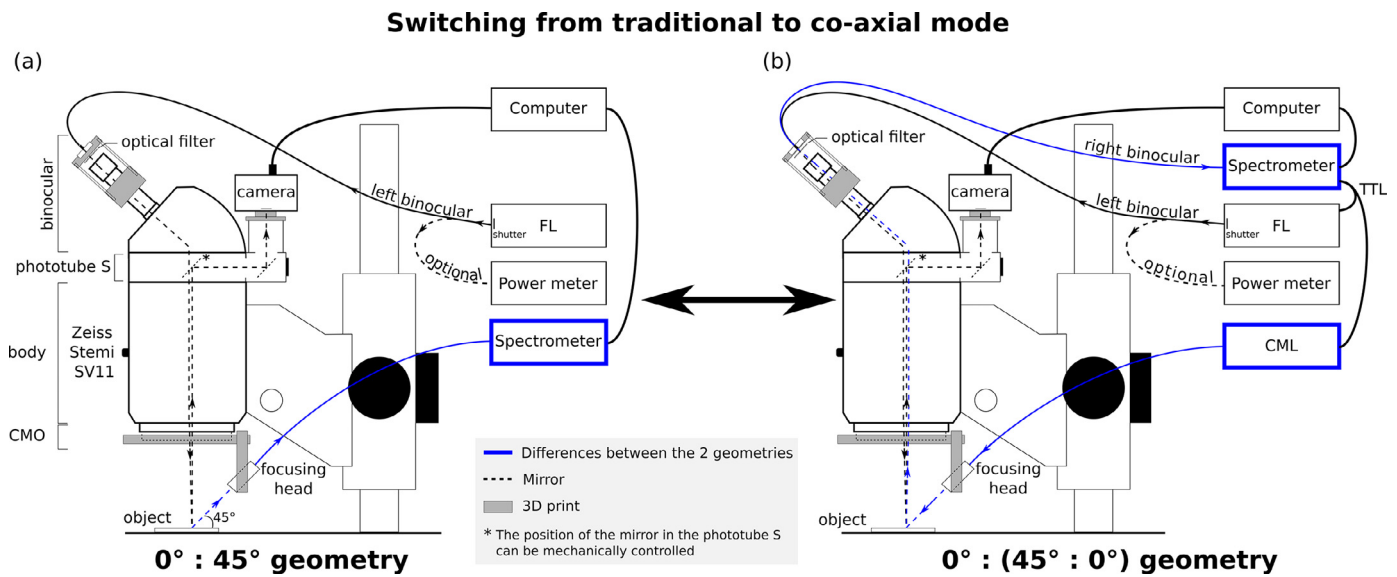

Fig. 4. 2D representations of the stereo-MFT: traditional mode (a); co-axial mode (b).

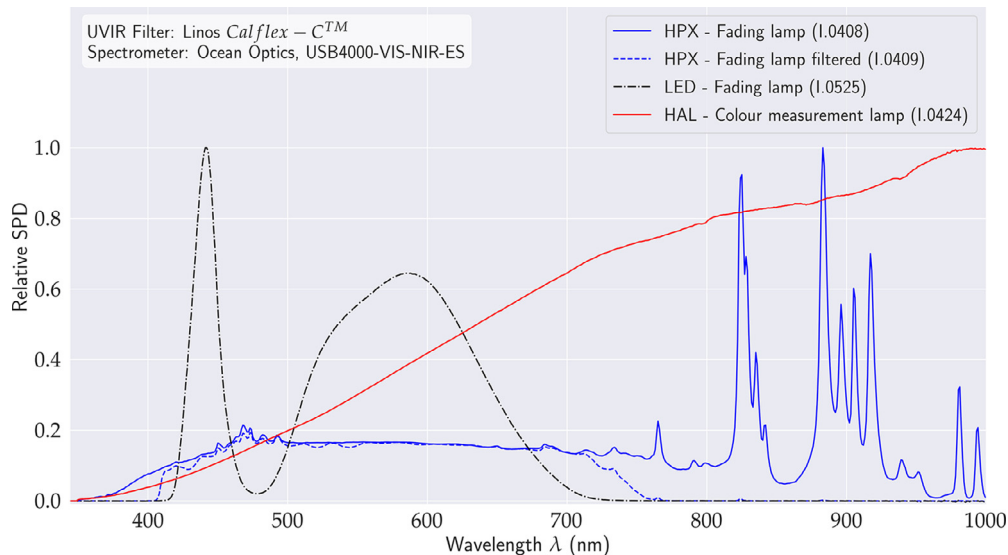

Fig. 5. Spectral power distribution of the light sources used in the stereo-MFT.

monitor changes. In the co-axial mode a halogen source is used to perform colour measurements, but one could replace it with a different lamp that is better suited to investigate changes that occur outside of the visible spectrum.

The  $0^\circ:(45^\circ:0^\circ)$  notation explicitly states that the colour measurement process (values in parenthesis) involves a colour measurement light source (CML) coupled with a focusing head that is placed to the side at a  $45^\circ$  angle while the spectrometer is positioned above the normal. In this configuration, the fading light source (FL) is still positioned above the sample - hence projecting a vertical beam (Fig. 3, (a)) and the  $0^\circ$  value on the left side of the notation. This means that when the fading lamp is being unshuttered, its light beam interferes with the colour measurement process. In other words, the reflected radiation of the fading beam cannot be directly collected by the spectrometer in order to monitor changes. Therefore, in this arrangement the fading beam needs to be blocked, i.e. shuttered, and a separate light source (CML) is required in order to correctly perform colour measurements (Fig. 3, (b)). In contrast with regular MFT devices where the fading and

colour measurement processes happen simultaneously, the stereo-MFT has been designed to alternate between these two processes, which requires controlling the shutter of both light sources (FL and CML). The Transistor-Transistor-Logic (TTL) function on both lamps enables them to be controlled by an external spectrometer. In the present configuration, the software of the spectrometer (Tidas DAQ3) enables the user to write programming scripts that control the two light sources and the spectrometer, hence defining a cycle of actions that can be repeated as often as needed (Fig. 3, (c)).

Lack of precision regarding the characterization and control of the beam's dimensions and power hinders reliable monitoring of colour change as a function of energy. In the stereo-MFT, this issue has been overcome by combining the optics of the stereomicroscope with a high quality imaging system and a power metre. The implementation of a camera connected to the phototube S enables the user to capture photographs of the fading beam from which its dimensions can easily be calculated (Fig. 6, (a) and (c)). Combining photographs of the beam with total power values enables an esti-

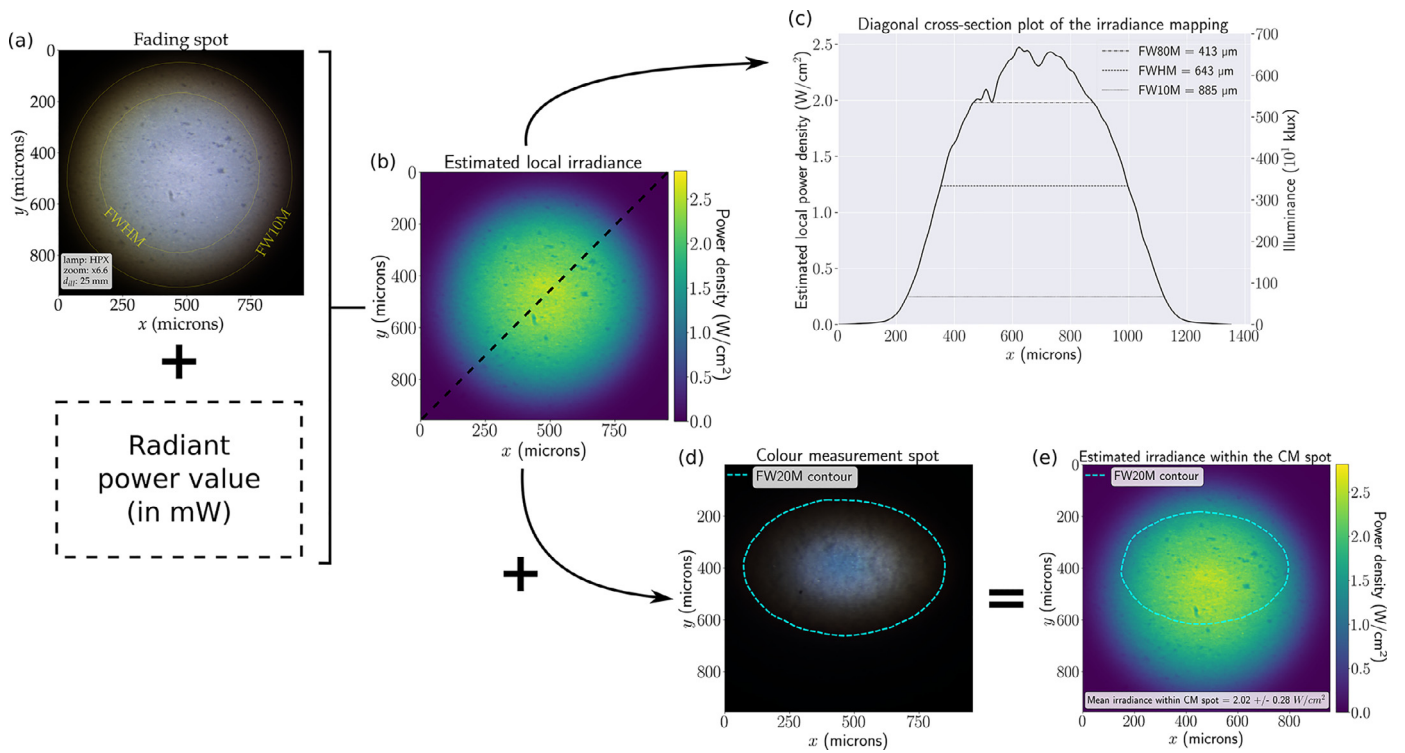

**Fig. 6.** Beams characterization: photograph of the fading spot (a); power density distribution (b); profile of the power density distribution (c); photograph of the colour measurement spot (d); power density distribution within the colour measurement spot (e).

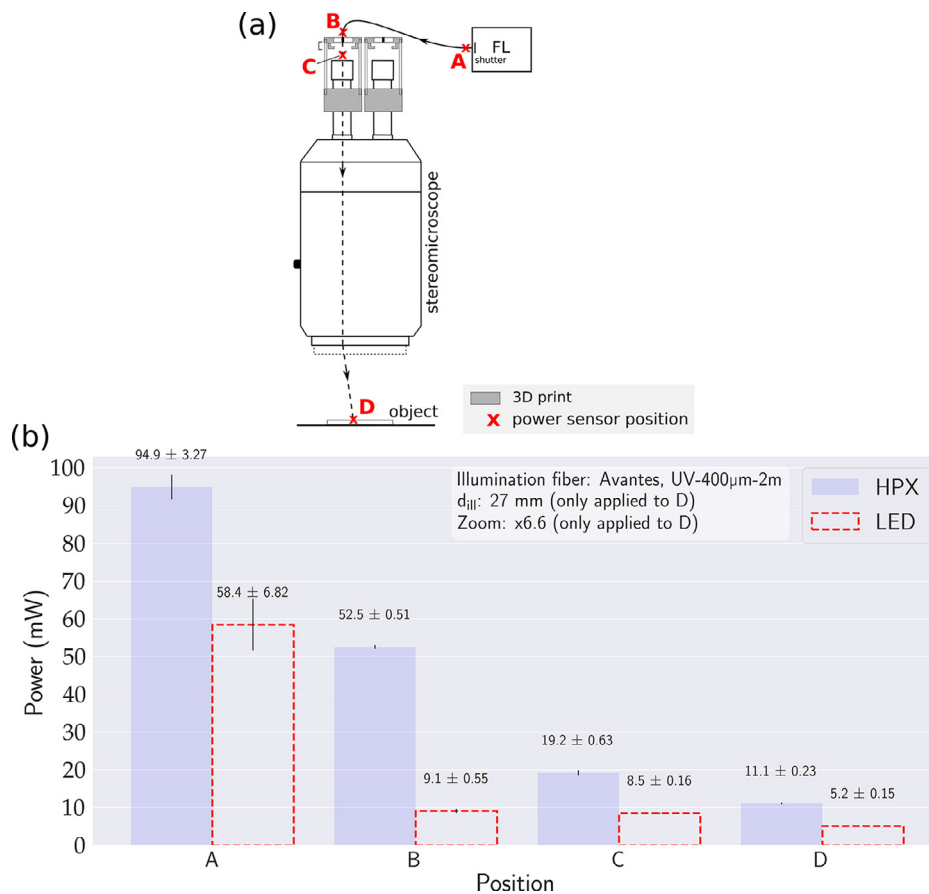

**Fig. 7.** Variations of power according to the position within the stereo-MFT: location of each position (a); power values for each position (b).

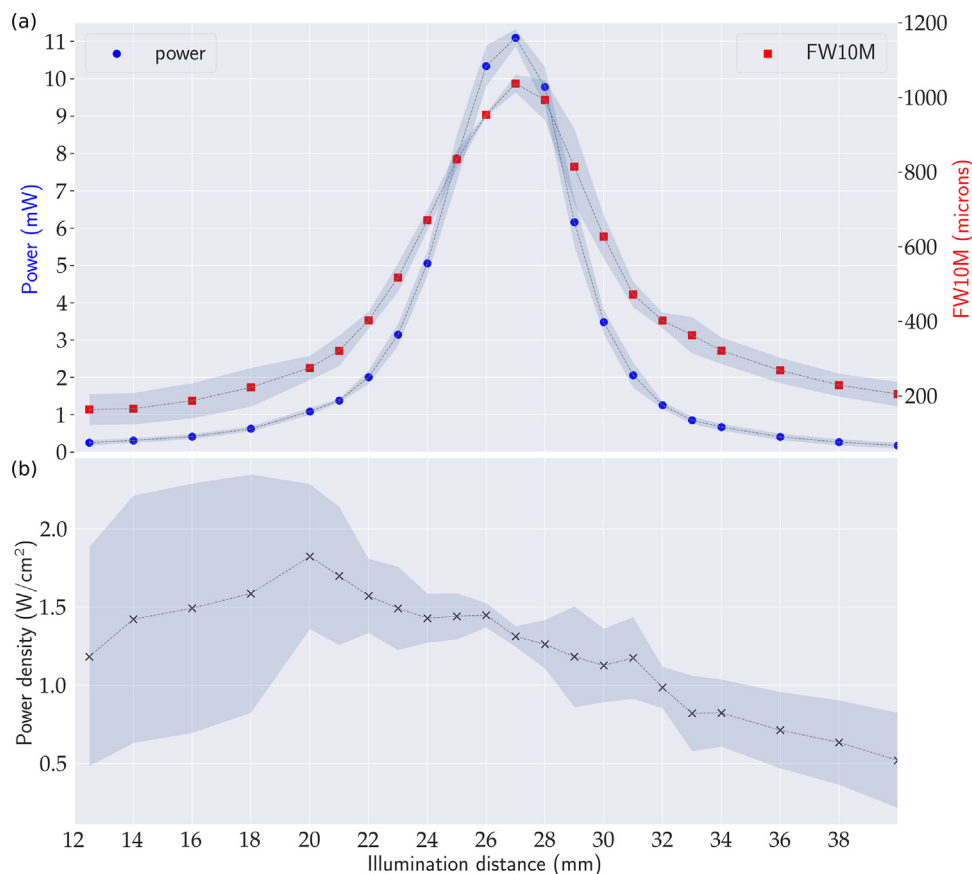

Fig. 8. High power xenon lamp: Influence of the illumination distance over the power and FW10M (a) and over the power density (b).

mation of the power density distribution within the fading beam (Fig. 6, (b)), from which a mean irradiance value can be calculated and multiplied by the duration of the analysis in order to provide a radiometric energy scale in joules per square metre ( $\text{J}/\text{m}^2$ ), ultimately used to monitor colour change. In addition, photographs of the colour measurement spot in the traditional mode can be taken, so that precise distribution of the light energy density within the colour measurement spot can be determined (Fig. 6, (d) and (e))<sup>8</sup>. Coupling the camera with the stereomicroscope optics also facilitates the alignment and optimization of the beams which can be done by focusing the stereomicroscope through the camera. In other words, when the image is sharp, the fading beam spot and the colour measurement spot are aligned so that the spectrometer measures the colour exactly where the fading process occurs. Finally, photographs of the samples could potentially provide useful information regarding the interpretation of the data.

Control over the beams' dimensions and power is achieved by changing the zoom setting on the stereomicroscope, or by modifying the illumination distance ( $d_{\text{ill}}$ ), i.e. the distance between the output of the optical fibre and the objective of the left binocular (Fig. 2). The ability to vary the dimensions of the fading beam spot and its power enables the user to adjust them according to experimental needs so that optimal values can be used. For example, for analyses on cultural heritage objects one might choose to minimise damage, thus prioritising a smaller spot size and requesting the ability to stop the analysis before any visible change occurs, while for experiments on mock-up samples one could favour

a larger spot size in order to maximise features related to the spectral information collected.

Finally on a non-technical level, we recognized from the beginning that the successive improvements following the development of the *Oriel-MFT* were only possible because people and institutions were able to appropriate the device and modify it to meet their specific needs. Hence, an integral aspect of the design of our device was placed on insuring modularity of the parts to allow the user to modify elements such as lamps, optical fibers, filters, camera, etc. The use of open source software and 3D prints is part of the same approach of giving the user the possibility to appropriate the tools of research. In a general way, we believe that meaningful progress comes from responsible users rather than blind consumers, which is what we have tried to convey through the conception of the stereo-MFT.

### 3.2. Characterization of the device

#### 3.2.1. Light sources

As mentioned, the stereo-MFT contains two light sources: one for the colour measurement process (CML) and another for the fading process (FL). For the colour measurement, a halogen light (HAL) has been chosen as a suitable light source [21, p.6]. The relative spectral power distribution (SPD) for all light sources were measured with an Ocean Optics spectrometer (USB4000-VIS-NIR-ES) and a cosine corrector (Fig. 5)<sup>9</sup>. Two fading light sources have been tested in the framework of this project, both representative of museum lighting conditions. One is a high power xenon light source from Ocean Optics which represents daylight conditions in

<sup>8</sup> Unfortunately, this feature is currently only available for the traditional mode of the stereo-MFT.

<sup>9</sup> Parameters of the measurements are provided in S.I. n°03.

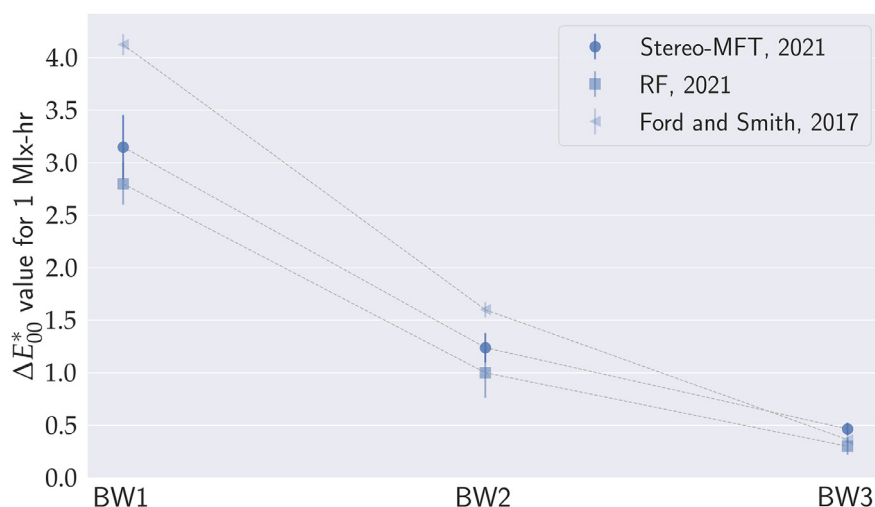

Fig. 9. Micro-fading data comparison with past studies on blue wool standards.

museums with the possibility of blocking the UV and IR radiation with a filter (Linco CalflexTM-C, G380 220 032), while the other is a high power warm white LED (4000 K) from Thorlabs. The latter is taken to represent a more recent source of illumination frequently adopted by museums. However, warmer LED lamps are usually used in galleries, i.e. with a correlated colour temperature (CCT) around 3000 K, but it proved to be difficult to find a commercially available high power LED with a CCT of 3000 K. Using different types of light sources that reflect actual museum practice is desired when applying micro-fading data to conservation challenges as performing micro-fading analyses with a high power xenon lamp on objects that are exhibited with LED light sources can limit the usefulness of the acquired data.

### 3.2.2. Fading beam

Two aspects of the fading beam have been characterised: the power values at different positions in the set-up and the influence of the illumination distance.

In Fig. 4, a dash line has been drawn (labelled *optional*) that represents the connection between the fading light source and the power metre. This represents the possible use of a bifurcated optical fibre splitting the initial beam into two equal beams. Such an option enables the user to simultaneously measure the power while performing a micro-fading analysis. In cases where the energy output of the fading light source is unstable over time, one would want to record the power levels during a micro-fading analysis. By knowing the influence of each component (optical fibre, filter and microscope) on the power, one can back calculate the total amount of radiant power received by the object from the recorded values given by the power metre.

In order to assess the influence of each component, the power of the fading beam has been characterised at four different positions within the system (Fig. 7, (a), positions A–D). The first location - spot A - consists of placing the power metre just outside of the fading light source. At location B, the influence of the optical fibre is assessed, whereas at location C the effect of the UV-IR filter is evaluated. Finally, position D characterises the fading beam received by the object and allows us to establish the influence of the microscope's optics. For this latter position, the power was also measured at different illumination distances ( $d_{ill}$ ). In all cases, the power values of the fading beam were recorded with a power metre from Thorlabs (PM100USB combined with a S405C sensor). Similarly, the size of the beam was calculated at different illumination distance values. The full width at 10% maximum (FW10M) has been chosen as an approximation of the beam diameter and

was calculated from photographs of the fading beam reflected by the surface of a perfect reflecting diffuser (Barium sulfate pressed powder) and taken with a microscope camera from The Imaging Source (DFK 33UX183).

The results of the power indicate a strong decrease as light travels through the device for both types of light sources (Fig. 7, (b)). In the best case, only about 9 and 12% of the initial light energy arrives on the sample's surface for the LED and HPX lamps respectively (Fig. 7, (b), ratio A/D). A loss of energy first occurs when the emitted light enters the optical fibre (Fig. 7, (b), ratio A/B). A larger fibre diameter would increase the amount of energy transmitted but would also result in a larger beam size. The filter has a greater influence on the xenon light source than on the LED one. Looking at Fig. 5, it can be seen that all wavelengths below 400 nm and above 750 nm are cut off by the filter, explaining the decrease in power (ratio B/C). The multiple lenses contained in the stereo-microscope also reduce the light energy by an approximate factor of 1.6 (ratio C/D).

The influence of the illumination distance is displayed in Fig. 8. The results show that the illumination distance significantly influences both the power and the FW10M simultaneously and in a similar way; although the variations in power are clearly more affected by changes in the illumination distance than the FW10M (Fig. 8, (a)). On the contrary, the power density is more or less constant across the illumination distance range, at least between 12.5 and 31 mm.

### 3.3. Micro-fading analyses

In order to demonstrate the micro-fading ability of this new device, measurements on blue wool standards (Beuth Verlag GmbH - BW1, BW2, and BW3) were performed<sup>10</sup>. These standards have been chosen because they enable us to compare our results with those of benchmark devices - such as the *Oriel-MFT* - that can be found in the literature [22,23,14,24]. The aim is not so much to perform deep and accurate comparison between micro-fading results obtained on different devices<sup>11</sup> as to illustrate the micro-

<sup>10</sup> This article is a stand-alone contribution without particular application which will serve as a foundation for further projects such as case-studies, light ageing experiments, or fundamental research.

<sup>11</sup> A number of parameters - such as the type of the BWS, or differences in the experimental methods - can potentially caused differences in the fading behaviours which then limit interpretation of the results and comparison of analyses performed with different devices.



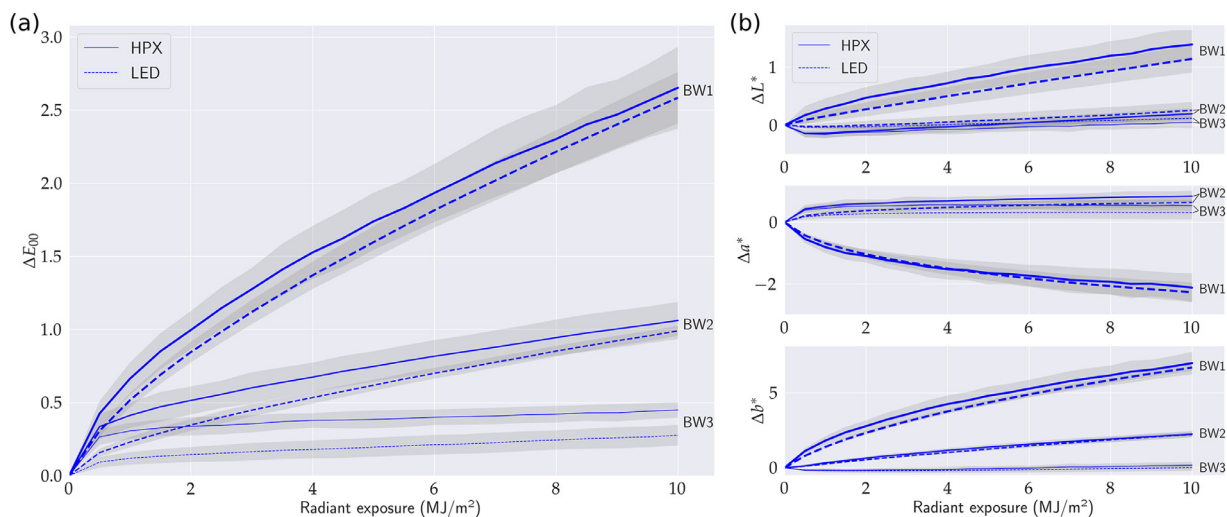

Fig. 10. Micro-fading results of the traditional mode rounds:  $\Delta E^*_{00}$  curves (a); variations in the CIE  $L^* a^* b^*$  coordinates (b).

fading ability of the stereo-MFT on samples that are regularly faded by MFT users.

Three different configurations of the system have been used and compared. First, a round of analyses was performed in the co-axial mode with the high power xenon lamp in combination with the UVIR filter previously mentioned. Subsequently, rounds of analyses in the traditional mode were performed with the LED and the HPX lamps; similarly the UVIR filter was used with the latter lamp. For each round of analyses, the blue wool standards were measured three consecutive times on four different days resulting in a total of 12 analyses per round; mean and standard deviation values were subsequently calculated. The parameters of the micro-fading device for each round are given in the Supplementary Information section (S.I. n°04). Reflectance data were processed with the Colour science python package inside a Jupyter notebook environment [25–28] in order to obtain the CIE  $L^* a^* b^*$  and the  $\Delta E^*_{00}$  values [29]. This latter colour difference equation was chosen because it is widely used among researchers studying colour change phenomena and is currently recommended by the Commission International de l'Eclairage (CIE) [30].

#### 4. Results and discussion

Observation of the micro-fading results (Fig. 10) enables us to draw several statements. First of all, the results show fading behaviours that are in agreement with the indication of the manufacturer reporting a factor of approximately two between each subsequent blue wool category<sup>12</sup>. Secondly, no significant differences in the  $\Delta E^*_{00}$  values values between the two modes of operation (co-axial vs traditional; both modes used the HPX lamp) have been observed<sup>13</sup>, which is consistent with the fact that the fading process is similar from one mode to another - in other words the amount of energy received by the samples is identical in both modes. At first glance, the spectral power distribution of the light source does not seem to affect the colour change behaviours, which are comparable from one lamp to another when a radiometric scale is used (Fig. 10, (a))<sup>14</sup>. Likewise, the CIE  $L^* a^* b^*$  values vary in similar proportion whether one uses a high power xenon light source or a high power LED (Fig. 10, (b)). A more rigorous compar-

ison between the light damage ability of both lamps would require identical colour measurement process which could be done in the co-axial if one is able to control the high power LED lamp<sup>15</sup>.

Three main outcomes can be drawn from these observations:

- The data demonstrate the ability of the stereo-MFT to monitor light-induced colour changes.
- The results outline the importance of using radiometric scale when comparing light-induced colour change data where several types of light source have been used.
- As long as the UV and IR radiation are filtered, the influence of the light source on the micro-fading behaviour of the material is rather limited, at least for the blue wool samples; wavelength dependency has been showed for several materials found in works of art [31,32].

Comparing our data against those found in the literature can be quite challenging because of the many differences in terms of methodology and technological aspects. Proper comparisons should involve a similar colour change unit,  $\Delta E^*_{00}$  in this case, as a function of radiant exposure in  $J/m^2$ . However the use of a radiometric scale in the cultural heritage field, especially in micro-fadeometry, is rarely observed. Consequently, we turned instead to compare data from two different sources according to the exposure dose in  $Mlx-hr$  (Fig. 9). The first set of data was deduced from the article written by Ford and Smith [22, Figs. 2, 5, 6, and 7], while the second set was provided to us by the Rathgen Forschungslabor, Berlin. In all three datasets, the  $\Delta E^*_{00}$  values are clearly distinct according to the blue wool category. In addition, the ratio between subsequent blue wool category is comparable across the three datasets. This demonstrates the ability of micro-fading devices to distinguish the fading properties of blue wool standards and also indicates that the blue wool scale is a lightfastness ranking system that works pretty well. However, the data provided by the stereo-MFT in addition to our own experience with micro-fadeometry suggests that the ability of these blue wool standards to reach comparable  $\Delta E^*_{00}$  values when submitted to similar exposure dose is rather low. In other words, the BWS lack reproducibility in the context of micro-fading analyses. The intertwining of perpendicular chaining and filling threads creates an uneven surface alternating between bump and hollow spaces with dimensions comparable to the diameter of the fading beam. Depending

<sup>12</sup> <https://www.james-heal.co.uk/essentials-blue-wool-standards-how-to-use/> (consulted on 17/06/2021).

<sup>13</sup> A graph is available in S.I. n°05.

<sup>14</sup> A graph of Figure 10 using a photometric scale (klux-hr) is provided in S.I. n°06.

<sup>15</sup> The possibility to perform analyses in the co-axial mode with the high power LED lamp is currently under development.

on the location of the beam spot on the BWS sample - bump, hollow or in between – the  $L^*a^*b^*$  and  $\Delta E$  values will differ [33]. Consequently, the use of these standards as a dosimeter system is limited<sup>16</sup>. In the context of dose-response studies, alternatives to the BWS would be worth to investigate; photometric ink<sup>17</sup> or actinometer could be potential options but much research will be required before any implementation in the field of heritage science.

## 5. Conclusion

This article describes the implementation of a new micro-fading system for which comparison with benchmark data found in the literature has been performed. The use of a stereo-microscope as a central element of this new set-up provided high quality optics which allowed us to implement a new measurement geometry and to separate the fading process from the colour measurement process. This latter innovation opens new opportunities by giving researchers a suitable and flexible system to conduct light-induced degradation studies. Strong emphasis was placed on the use of computational tools and high quality images. Our belief is that these two aspects will become increasingly prevalent in the heritage field precipitated our desire to foster their implementation and to orientate the field of micro-fadeometry towards a more image-based technique. Such initiatives can open new perspectives regarding the interaction between different fields of knowledge and expertise, leading to a better understanding and assessment of our heritage.

Though micro-fadeometry has already demonstrated positive outcomes for the conservation of cultural heritage objects, there are still many aspects that limit the development of the technique and its application to the field of heritage. Two of these issues have been mentioned in this article. The first one is the inadequate use of blue wool standards as a dosimeter system in micro-fadeometry. While the other one is a lack of an adequate and reproducible methodology necessary to properly investigate reciprocity failure phenomena for which the development of the stereo-MFT brings a contribution. Despite the many issues, we are convinced of the great potential that micro-fadeometry can offer to the field of conservation and heritage science.

## CRedit authorship contribution statement

**Gauthier Patin:** Conceptualization, Funding acquisition, Data curation, Writing – original draft, Visualization. **Robert G. Erdmann:** Conceptualization, Data curation, Supervision, Writing – review & editing. **Frank Ligterink:** Conceptualization, Supervision, Writing – review & editing, Funding acquisition. **Klaas Jan van den Berg:** Supervision, Writing – review & editing. **Ella Hendriks:** Writing – review & editing, Writing – review & editing, Funding acquisition.

## Acknowledgments

The authors wish to thank Dann Giesen (Technical Department, University of Amsterdam) and Tamar Davidowitz (Metals Conservation Department, Rijksmuseum) for their involvement in the fabrication of the 3D prints. We are also grateful to Harald Nitsche and Dag Kubin (J&M Analytik) for their support regarding the configuration of the spectrometer. We would also like to thank Bruce Ford

<sup>16</sup> A dosimeter system relates a dose value, either in terms of photometric (lux-hr) or radiometric units (J/m<sup>2</sup>), to a specific amount of changes, either in terms of spectral or colorimetric units. On the other hand, a lightfastness ranking system provides a standardized scale within which the results of lightfastness analyses on objects can be compared.

<sup>17</sup> Unpublished but promising results on the use of photochromic inks as have been obtained by Johan G. Neevel (pers. comm.).

and Stefan Röhrs (Rathgen Forschungslabor, Berlin) for facilitating the use of their micro-fading data. Finally, Chun (Tracy) Liu for editorial corrections and comments.

## Funding

This work as supported by the VGM-ASML Partnership in Science as well as the AXA Research Fund.

## Supplementary materials

Supplementary material associated with this article can be found, in the online version, at doi:[10.1016/j.culher.2022.08.012](https://doi.org/10.1016/j.culher.2022.08.012).

## References

- [1] International Organization for Standardization. Textiles - tests for colour fastness Part B02: colour fastness to artificial light: xenon arc fading lamp test. Technical Report ISO 105-B02:2014, 2014.
- [2] CIE Technical Committee 3-22. Control of damage to museum objects by optical radiation. Technical Report CIE 157:2004, Commission Internationale de l'Eclairage, 2004.
- [3] RL. Feller, Contrôle des effets détériorants de la lumière sur les objets de musée, *Museum XVII* (2) (1964) <http://unesdoc.unesco.org/images/0012/001273/127380fo.pdf>.
- [4] J. Ashley-Smith, A. Derbyshire, B. Pretzel, The continuing development of a practical lighting policy for works of art on paper and other object types at the victoria and Albert Museum, in: R. Vontobel (Ed.), Proceedings of the 13th Triennial Meeting, Rio de Janeiro, ICOM Committee for Conservation, 2002 22-27 September 2002: preprints.
- [5] S. Michalski, The lighting decision, in: Proceedings of the Preprints of a Conference: Textile Symposium 97 Fabric of an Exhibition: An Interdisciplinary Approach, 1997.
- [6] S. Michalski. Light, ultraviolet and infrared, Canadian Conservation Institute, 2018. <https://www.canada.ca/en/conservation-institute/services/agents-deterioration/light.html#shr-pg0>.
- [7] D. Saunders, *Museum Lighting: A Guide for Conservators and Curators*, Getty Publications, Los Angeles, 2020 ISBN 978-1-60606-637-9.
- [8] J. Ashley-Smith, *Risk Assessment for Object Conservation*, Butterworth-Heinemann, Oxford; Auckland; Boston, 1999 ISBN 978-0-7506-2853-2.
- [9] PM. Whitmore, X. Pan, C. Bailie, Predicting the fading of objects: identification of fugitive colorants through direct nondestructive lightfastness measurements, *J. Am. Inst. Conserv.* 38 (3) (1999) 395–409, doi:[10.1179/019713699806113420](https://doi.org/10.1179/019713699806113420).
- [10] B. Pretzel, Determining the lightfastness of the bullerwood carpet, *Stud. Conserv.* 45 (Suppl-1) (2000) 150–154 January, doi:[10.1179/sic.2000.45.Supplement-1.150](https://doi.org/10.1179/sic.2000.45.Supplement-1.150).
- [11] P. Whitmore, C. Bailie, S. Connors, Micro-fading tests to predict the result of exhibition: progress and prospects, in: A. Roy, P. Smith (Eds.), Proceedings of the Tradition and Innovation: Advances in Conservation: Contributions to the Melbourne Congress, 2000, pp. 200–205. 10-14 October.
- [12] A. Lerwill, J.H. Townsend, J. Liang, H. Thomas, S. Hackney, A portable micro-fading spectrometer for versatile lightfastness testing, *E-Preserv. Sci.* 5 (2008) 17–28.
- [13] H. Liang, R. Lange, A. Lucian, P. Hyndes, J.H. Townsend, S. Hackney, Development of portable microfading spectrometers for measurement of light sensitivity of material, in: J. Bridgland (Ed.), Proceedings of the ICOM Committee for Conservation, ICOM-CC, 16th Triennial Conference, Lisbon, 2011 19-23 September 2011.
- [14] C. Pesme, A. Lerwill, V. Beltran, J. Druzik, Development of contact portable micro-fade tester to assess light sensitivity of collection items, *J. Am. Inst. Conserv.* 55 (2) (2016) 117–137, doi:[10.1080/01971360.2016.1154430](https://doi.org/10.1080/01971360.2016.1154430).
- [15] E. Zeiss. SV6 and SV11 stereomicroscopes – operating instructions. Deutsches Institut für Normung e. V. DIN EN ISO 105-B02:2014-11, Textilien - Farbechtheitsprüfungen - Teil B02: Farbechtheit gegen künstliches Licht: Xenonbogenlicht (ISO 105-B02:2014); Deutsche Fassung EN ISO 105-B02:2014. Beuth Verlag GmbH, Berlin, 2014.
- [16] B. Ford, N. Smith, The development of a significance-based lighting framework at the National Museum of Australia, *AICCM Bull.* 32 (2011) 80–86.
- [17] LS. Harrison. Report on the deteriorating effects of modern light sources. Technical report, Metropolitan Museum of Art, New York, 1953. <https://cdm16028.contentdm.oclc.org/digital/collection/p15324coll10/id/175766>.
- [18] E. Sirri Aydinli, HG.S Krochmann, and J. Krochmann. On the deterioration of exhibited museum objects by optical radiation. Technical Report 89/3, Commission Internationale de l'Eclairage, 1990.
- [19] M. Julio del Hoyo-Meléndez, M. Mecklenburg, An investigation of the reciprocity principle of light exposures using microfading spectrometry, *Spectrosc. Lett.* 44 (1) (2011) 52–62, doi:[10.1080/00387010903508572](https://doi.org/10.1080/00387010903508572).
- [20] Zeiss. SV6 and SV11 stereomicroscopes – operating instructions.
- [21] R. Johnston-Feller, Color Science in the Examination of Museum Objects: Non-destructive Procedures, Getty Conservation Institute, Los Angeles, CA, 2001 ISBN 0-89236-586-2 [http://hdl.handle.net/10020/gci\\_pubs/color\\_science](http://hdl.handle.net/10020/gci_pubs/color_science).
- [22] B. Ford, N. Smith, A reality check for micro-fade testing: five examples, in: Proceedings of the ICOM-CC 18th Triennial Conference, Copenhagen, ICOM Committee for Conservation, 2017 4-7 September 2017.

- [23] S. Tse, Microfade testing for heritage institutions: a canadian experience, *Stud. Conserv.* 64 (6) (2018) 337–351 ISSN 0039-3630, doi:[10.1080/00393630.2018.1527984](https://doi.org/10.1080/00393630.2018.1527984).
- [24] C. Morales-Merino, S. Röhrs, F. Meyer, S. Marten, I. Reiche, Micro-fading testing on modern ink based pens and contemporary drawings from the Kupferstichkabinett. *Berliner, Beitr. Archäomeatrie Kunsttechnol. Konserv.* 24 (2016) 89–102.
- [25] T. Mansencal, M. Mauderer, M. Parsons, N. Shaw, K. Wheatley, S. Cooper, J.D. Vandenberg, L. Canavan, K. Crowson, O. Lev, K. Leinweber, S. Sharma, T.J. Sobotka, D. Moritz, M. Pppp, C. Rane, P. Eswaramoorthy, J. Mertic, B. Pearlstone, M. Leonhardt, O. Niemitalo, M. Szymanski, M. Schambach, S. Huang, M. Wei, N. Joywardhan, O. Wagih, P. Redman, J. Goldstone, S. Hill, J. Smith, F. Savoie, G. Saxena, S. Chopra, I. Sibiryakov, Tim gates, gajendra pal, nicolas tessore, and aurélien pierre. Colour 0.4.1, February 2022. doi:[10.5281/zenodo.6288658](https://doi.org/10.5281/zenodo.6288658).
- [26] CR. Harris, K.J. Millman, S.J. Walt, R. Gommers, P. Virtanen, D. Cournapeau, E. Wieser, J. Taylor, S. Berg, N.J. Smith, R. Kern, M. Picus, S. Hoyer, M.H. Kerkwijk, M. Brett, A. Haldane, J.F. Rió, M. Wiebe, P. Peterson, P. Gérard-Marchant, K. Sheppard, T. Reddy, W. Weckesser, H. Abbasi, C. Gohlke, T.E. Oliphant, Array programming with NumPy, *Nature* 585 (7825) (2020) 357–362 September ISSN 1476-4687 <https://www.nature.com/articles/s41586-020-2649-2> , doi:[10.1038/s41586-020-2649-2](https://doi.org/10.1038/s41586-020-2649-2).
- [27] J.D. Hunter, Matplotlib: a 2D graphics environment, *Comput. Sci. Eng.* 9 (3) (2007) 90–95, doi:[10.1109/MCSE.2007.55](https://doi.org/10.1109/MCSE.2007.55).
- [28] W. McKinney, Data structures for statistical computing in python, in: S. van der Walt, J. Millman (Eds.), *Proceedings of the 9th Python in Science Conference*, 2010, pp. 51–61, doi:[10.25080/MAJORA-92BF1922-00A](https://doi.org/10.25080/MAJORA-92BF1922-00A).
- [29] T. Kluyver, B. Ragan-Kelley, F. Pérez, B. Granger, M. Bussonnier, J. Frederic, K. Kelley, J. Hamrick, J. Grout, S. Corlay, P. Ivanov, D. Avila, S. Abdalla, C. Willingjupyter development team, Jupyter notebooks - a publishing format for reproducible computational workflows, in: F. Loizides, B. Schmidt (Eds.), *Positioning and Power in Academic Publishing: Players, Agents and Agendas*, IOS Press, Netherlands, 2016, pp. 87–90. <https://eprints.soton.ac.uk/403913/>.
- [30] M.R. Luo, G. Cui, B. Rigg, The development of the CIE 2000 colour-difference formula: CIEDE2000, *Color Res. Appl.* 26 (5) (2001) 340–350 October.
- [31] CIE Technical Committee 1-55. Recommended method for evaluating the performance of colour-difference formulae. Technical Report 2017:2016, Commission Internationale de l'Eclairage, Vienna, Austria, 2016.
- [32] A. Lerwill, A. Brookes, J.H. Townsend, S. Hackney, H. Liang, Micro-fading spectrometry: investigating the wavelength specificity of fading, *Appl. Phys. A* 118 (2015) 457–463.
- [33] D. Saunders, Jo Kirby, Wavelength-dependent fading of artist' pigment, in: A. Roy, P. Smith (Eds.), *Preventive Conservation: Practice, Theory, and Research*, IIC, London, London, 1994, pp. 190–194.
- [34] T. Prestel, Alternative perspectives on blue-wool standards in microfading, in: *Proceedings of the Microfading Workshop & User Meeting*, Rathgen Forschungslabor, 2016 7th & 8th November 2016.
- [35] V.L. Beltran, C. Pesme, SK. Freeman, M. Benson, Microfading Tester: Light Sensitivity Assessment and Role in Lighting Policy, Getty Conservation Institute, Los Angeles, 2021 ISBN 978-1-937433-95-6 [https://www.getty.edu/conservation/publications\\_resources/pdf\\_publications/pdf/Microfading\\_Tester.pdf](https://www.getty.edu/conservation/publications_resources/pdf_publications/pdf/Microfading_Tester.pdf) .
- [36] B. Lavédrine, Development of microfading testing for transmission measurement on colour transparencies, in: *Proceedings of the Symposium Anoxia and Microfading, The Impact on Collection Care*, Tate Modern, Bankside, London, 2011 12-13 September.