



UvA-DARE (Digital Academic Repository)

Germline SMARCB1 mutation and somatic NF2 mutations in familial multiple meningiomas

Christiaans, I.; Kenter, S.B.; Brink, H.C.; van Os, T.A.M.; Baas, F.; van den Munckhof, P.; Kidd, A.M.J.; Hulsebos, T.J.M.

DOI

[10.1136/jmg.2010.082420](https://doi.org/10.1136/jmg.2010.082420)

Publication date

2011

Document Version

Final published version

Published in

Journal of Medical Genetics

[Link to publication](#)

Citation for published version (APA):

Christiaans, I., Kenter, S. B., Brink, H. C., van Os, T. A. M., Baas, F., van den Munckhof, P., Kidd, A. M. J., & Hulsebos, T. J. M. (2011). Germline SMARCB1 mutation and somatic NF2 mutations in familial multiple meningiomas. *Journal of Medical Genetics*, 48(2), 93-97. <https://doi.org/10.1136/jmg.2010.082420>

General rights

It is not permitted to download or to forward/distribute the text or part of it without the consent of the author(s) and/or copyright holder(s), other than for strictly personal, individual use, unless the work is under an open content license (like Creative Commons).

Disclaimer/Complaints regulations

If you believe that digital publication of certain material infringes any of your rights or (privacy) interests, please let the Library know, stating your reasons. In case of a legitimate complaint, the Library will make the material inaccessible and/or remove it from the website. Please Ask the Library: <https://uba.uva.nl/en/contact>, or a letter to: Library of the University of Amsterdam, Secretariat, Singel 425, 1012 WP Amsterdam, The Netherlands. You will be contacted as soon as possible.

UvA-DARE is a service provided by the library of the University of Amsterdam (<https://dare.uva.nl>)

Germline *SMARCB1* mutation and somatic *NF2* mutations in familial multiple meningiomas

I Christiaans,¹ S B Kenter,² H C Brink,¹ T A M van Os,¹ F Baas,² P van den Munckhof,³ A M J Kidd,⁴ T J M Hulsebos²

¹Department of Clinical Genetics, Academic Medical Center, Amsterdam, The Netherlands

²Department of Neurogenetics, Academic Medical Center, Amsterdam, The Netherlands

³Department of Neurosurgery, Academic Medical Center, Amsterdam, The Netherlands

⁴Canterbury Health Laboratories, Christchurch, New Zealand

Correspondence to

Dr Theo J M Hulsebos, Department of Neurogenetics, Academic Medical Center, Room K2-216, Meibergdreef 9, Amsterdam 1105 AZ, The Netherlands; t.j.hulsebos@amc.uva.nl

Received 29 June 2010

Revised 12 August 2010

Accepted 23 August 2010

Published Online First

7 October 2010

ABSTRACT

Background Multiple meningiomas occur in <10% of meningioma patients. Their development may be caused by the presence of a predisposing germline mutation in the neurofibromatosis type 2 (*NF2*) gene. The predisposing gene in patients with non-*NF2* associated multiple meningiomas remains to be identified. Recently, *SMARCB1* was reported to be a potential predisposing gene for multiple meningiomas in a family with schwannomatosis and multiple meningiomas. However, involvement of this gene in the development of the meningiomas was not demonstrated.

Results Five affected members of a large family with multiple meningiomas were investigated for the presence of mutations in *SMARCB1* and *NF2*. A missense mutation was identified in exon 2 of *SMARCB1* as the causative germline mutation predisposing to multiple meningiomas; furthermore, it was demonstrated that, in accordance with the two-hit hypothesis for tumorigenesis, the mutant allele was retained and the wild-type allele lost in all four investigated meningiomas. In addition, independent somatically acquired *NF2* mutations were identified in two meningiomas of one patient with concomitant losses of the wild-type *NF2* allele.

Conclusion It is concluded that, analogous to the genetic events in a subset of schwannomatosis associated schwannomas, a four-hit mechanism of tumour suppressor gene inactivation, involving *SMARCB1* and *NF2*, might be operative in familial multiple meningiomas associated meningiomas.

INTRODUCTION

Meningiomas are among the most common intracranial primary tumours (20% of all brain tumours), usually occurring as slowly growing sporadic solitary lesions.¹ They also develop in about 50% of patients with neurofibromatosis type 2 (*NF2*). The hallmark of *NF2* is the presence of bilateral vestibular schwannomas. Schwannomas at other locations are found in more than 50% of patients.^{2–4} *NF2* patients carry a heterozygous germline mutation in the *NF2* gene and the wild-type copy of this gene is often found to be lost in the *NF2* associated tumours.^{5–7}

Multiple meningiomas occur in <10% of patients with meningioma.⁸ These may be *NF2* associated and in those cases develop as the consequence of the presence of a predisposing *NF2* germline mutation. Non-*NF2* associated multiple meningiomas may occur as sporadic or familial cases. The limited number of meningiomas of familial

multiple meningioma patients investigated thus far did not display somatic or constitutional *NF2* mutations.^{9–10} The multiple tumours of sporadic patients were found to carry an identical somatic *NF2* mutation, which was not present in their constitutional DNAs.^{9–13} This might be explained by spread via the cerebrospinal fluid or distant metastasis of a single tumour or as a consequence of mosaicism with undetectable contribution of the *NF2* mutation to the constitutional DNA. Alternatively, the non-*NF2* sporadic and familial cases suggest that a gene different from *NF2* is implicated in the development of non-*NF2* associated multiple meningiomas. This contention is supported by an earlier linkage study in a family with meningiomas in which a 15 cM region around and including *NF2* was excluded from harbouring the meningioma predisposing gene.¹⁴

SMARCB1 is a predisposing gene in schwannomatosis, which is characterised by the presence of multiple schwannomas in the absence of vestibular schwannomas. The gene is involved in about 30–40% of the familial cases, but in no more than 10% of the sporadic cases. In the schwannomas of these patients, the wild-type copy of *SMARCB1* is found to be inactivated, usually by deletion. In addition, somatically acquired *NF2* mutations have been found in schwannomas of patients with a germline *SMARCB1* mutation.^{15–18}

We wondered whether *SMARCB1* might be a predisposing gene in multiple meningiomas as well. Support for this candidacy is given by the location of *SMARCB1*, which is proximal to marker D22S1, that is outside the region excluded by linkage analysis.¹⁴ Furthermore, somatic *SMARCB1* mutations have been shown to occur in sporadic meningiomas, albeit at low frequency, that is <3% of tumours.^{19–21} Evidence for the involvement of *SMARCB1* in multiple meningiomas was recently reported by Bacci *et al*,²² who showed the inheritance of a germline *SMARCB1* mutation in a family with schwannomatosis and multiple meningiomas. However, the mutational status of *SMARCB1* (and of *NF2*) in the meningiomas of the patients was not clarified. In another recent study, no germline *SMARCB1* mutation could be detected in 47 patients with multiple meningiomas, including eight familial cases.²³

In this study, we investigated a large family with three members affected by multiple meningiomas and two with a single meningioma. We identified the causative germline *SMARCB1* mutation segregating with (multiple) meningiomas in this family and demonstrated inactivation by deletion of the wild-type copy of *SMARCB1* and additional bi-allelic

and independent inactivation of *NF2* in meningiomas of the patients.

PATIENTS AND METHODS

Patients

Informed consent was obtained from all family members for using their body materials.

The proband (III-6 in figure 1) was referred to our outpatient clinic with a suspected diagnosis of NF2 because of multiple meningiomas. At the age of 34 years she presented with epilepsy. CT of the brain showed three extra-axial lesions along the falx cerebri, which were suspected of being meningiomas. Two lesions were resected and pathological examination confirmed the diagnosis of meningioma. At the age of 51 years, our proband developed sensory problems and paraplegia of the legs. MRI of the brain and spinal cord showed an intradural extramedullary lesion at thoracic level (T) 7, suspected of being a meningioma. The lesion was removed and turned out to be a psammomatous meningioma, WHO grade I. Her family history revealed a twin sister (III-7 in figure 1) with a chest wall schwannoma at age 37. At age 49, she developed epilepsy and brain MRI showed multiple extra-axial lesions, which were on histology transitional/mixed meningiomas grade I. She underwent additional surgery for a spinal fibroblastic meningioma at T4, multiple schwannomas of the chest wall and elbow, and was diagnosed with multiple spinal lesions suspected of being schwannomas. The father of these twin sisters died at age 63 from coronary artery disease. Two of his 10 siblings had been undergone surgery for meningioma. An uncle of our proband (II-6 in figure 1) developed left-sided deafness caused by a cerebellopontine angle mass, suspected of being a vestibular schwannoma, at age 56. At age 64, a spinal fibroblastic meningioma at T1 was removed; more recently, at age 77, he developed gait difficulties and MRI showed multiple spinal intradural extramedullary lesions, suspected of being meningiomas. An aunt of our proband (II-9 in

figure 1) underwent surgery on a spinal psammomatous meningioma at T10 at age 53. A fibrous meningioma at T6 was removed from the spinal cord of her daughter (III-1 in figure 1) at the age of 40 years.

None of the affected family members had neurofibromas, café-au-lait spots or freckling. Their clinical characteristics are summarised in table 1.

DNA and RNA samples

A frozen tissue sample of a brain meningioma M1 of patient III-6 and formalin fixed, paraffin embedded (FFPE) tissue samples of one meningioma each of patients II-6, II-9, and III-1, and the brain and spinal cord meningiomas (M1, M2) of patient III-6, were available for molecular analysis. DNA was extracted and purified from blood samples and the tumour tissue samples according to standard methods. DNA extracted from the meningioma of patient II-9 was too heavily degraded for reliable molecular analyses.

Total RNA was extracted and purified from another part of the frozen tissue sample of meningioma M1 of patient III-6 using TRIzol LS Reagent according to the protocol of the manufacturer (Invitrogen, Leek, The Netherlands). One microgram of total RNA was used to synthesise cDNA with random priming according to standard methods.

Microsatellite analysis

Genotyping of family members and loss of heterozygosity (LOH) analysis of tumours were performed by using the chromosome 22-specific microsatellite markers of the ABI Prism Linkage Mapping Set version 2.5-HD5 and additional marker D22S929. Primer sequences for the latter marker were taken from Legoux *et al.*²⁴ Data were analysed with Genemapper software version 4.0. (Applied Biosystems, Foster City, California, USA).

Mutation analysis

SMARCB1 and *NF2* were sequenced by using genomic or cDNA as substrate for amplification by PCR. Primer sequences for mutation analysis of the *SMARCB1* and *NF2* exons have been published previously.¹⁵ For improved performance, some *SMARCB1* primers were newly designed (sequences available on request). In degraded DNA extracted from FFPE material, the *SMARCB1* exon 2 segment harbouring the missense mutation was sequenced by using forward primer 5'-CCCTTATAATGAGCCTTCTTGCT-3' and reverse primer 5'-TCTTCCACAGTGGCTAGTCG-3', generating a PCR product of 116 bp.

The cDNA product from meningioma M1 of patient III-6 was sequenced by using forward primer 5'-GACGGCGAGTTC-TACAT-3' in exon 1 and reverse primer 5'-TTTTACCATGT-GACGATGCAA-3' at the 3'-end of exon 2, generating a PCR product of 148 bp. All sequence reactions were performed using ABI Big Dye v3.1 chemistry, and the products were sequenced with an ABI 3730 capillary system (Applied Biosystems). Sequences were analysed with CodonCode Aligner (CodonCode Corp, Dedham, Massachusetts, USA).

The HomoloGene program in PubMed was used to perform amino acid sequence alignments (<http://www.ncbi.nlm.nih.gov/pubmed>). The PolyPhen and SIFT programs were used to predict the impact of amino acid substitutions on protein function and structure (<http://genetics.bwh.harvard.edu/pph> and <http://sift.jcvi.org>, respectively).

RESULTS

Sequencing of the nine exons of *SMARCB1* in constitutional DNA of proband III-6 revealed a missense mutation in exon 2,

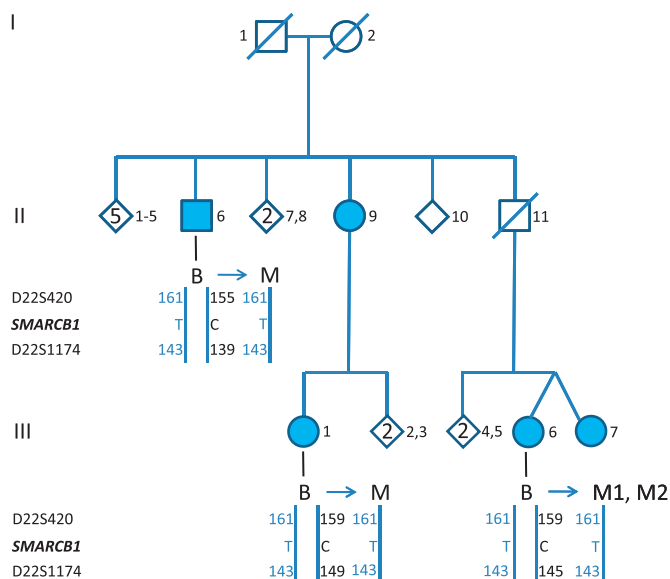

Figure 1 Genotyping of *SMARCB1* and flanking microsatellite markers in constitutional blood (B) and corresponding meningioma (M) DNA of affected members in a multiple meningiomas family. Patients with (multiple) meningiomas are marked by blue symbols. Diamond symbols indicate family members with insufficient clinical details (under clinical and molecular investigation). The wild-type and mutant allele of *SMARCB1* are indicated by C and T, respectively. Marker alleles are given by the length of their PCR products (bp).

Table 1 Clinical characteristics of affected family members

Patient	Sex (M/F)	Age (years) at diagnosis	Presenting symptom	Meningiomas (n, location)	Schwannomas (n, location)
III-6	F	34	Epilepsy	3 cranial, 1 spinal	—
III-7	F	37	Chest wall mass	Multiple cranial, 1 spinal	Multiple chest wall, multiple spinal, 1 elbow
II-6	M	56	Deafness	Multiple spinal	1 vestibular
II-9	F	53	Paresis legs	1 spinal	—
III-1	F	40	Sensory problems legs	1 spinal	—

c.143C→T, P48L (figure 2), which also proved to be present in constitutional DNA of the other affected family members (III-7, II-6, II-9, and III-1). The mutation was not found in constitutional DNA of more than 100 control individuals. The proline residue that is replaced by leucine in the resulting SMARCB1 protein is evolutionarily conserved across all species for which sequence information is available (data not shown). In silico analyses with the Polyphen and SIFT programs predicted that the amino acid substitution affects SMARCB1 protein function and is probably damaging.

The four meningiomas that were available for molecular analysis all showed loss of the wild-type C allele, as demonstrated in figure 2 for the brain (M1) and spinal cord (M2) meningioma of the proband (III-6). In accordance with this, genotyping with flanking markers revealed retention of the chromosome 22 segment containing the mutant T-allele in the investigated tumours, as exemplified in figure 2 for marker D22S1174. The data are summarised in figure 1.

To investigate whether the retained *SMARCB1* allele was transcribed, we extracted total RNA from frozen tissue of meningioma M1 and reverse transcribed it into cDNA. The cDNA sequence demonstrates that a stable mRNA is transcribed from the retained mutant allele (figure 2).

Schwannomatosis associated schwannomas harbour somatically acquired *NF2* mutations. Considering the apparent analogy with schwannomatosis, we wondered whether these mutations might also be present in the meningiomas of the family under study. Although attempts were made to sequence *NF2* in all available meningiomas, reliable sequences could only be derived from the frozen tumour M1 and the freshly fixed tumour M2, both of proband III-6. We found a missense mutation in exon 4 of meningioma M1 (c.422T→G, p.L141R) and a nonsense mutation in exon 8 (c.773G→A, p.W258X) of meningioma M2, both being absent in the corresponding constitutional DNA of the patient (figure 3). The leucine residue at position 141 is evolutionarily conserved (data not shown). The Polyphen and SIFT programs predicted that the amino acid substitution caused by the missense mutation affects *NF2* protein function and is probably damaging. The sequence recordings indicate loss of the wild-type allele in both tumours. This is substantiated by LOH analysis with the intragenic *NF2* marker D22S929, which shows considerable loss of the 132 bp allele in tumour M1 as well as tumour M2 (figure 3). Finally, we sequenced all exons of the *NF2* gene in constitutional DNA of the affected family members (III-6, III-7, II-6, II-9, III-1), but did not detect any deviation from the wild-type sequence.

Figure 2 Sequence analysis of part of exon 2 of *SMARCB1* and loss of heterozygosity (LOH) analysis with marker D22S1174 in blood and meningioma DNAs of patient III-6. Left: presence of the mutant T allele in constitutional blood (B) DNA and considerable loss of the wild-type C allele in genomic and cDNA of meningioma M1 and in genomic DNA of meningioma M2. Right: Presence of two alleles of marker D22S1174 in blood DNA and considerable loss of the 145 bp allele, marked by arrow, in meningioma M1 and M2 DNA.

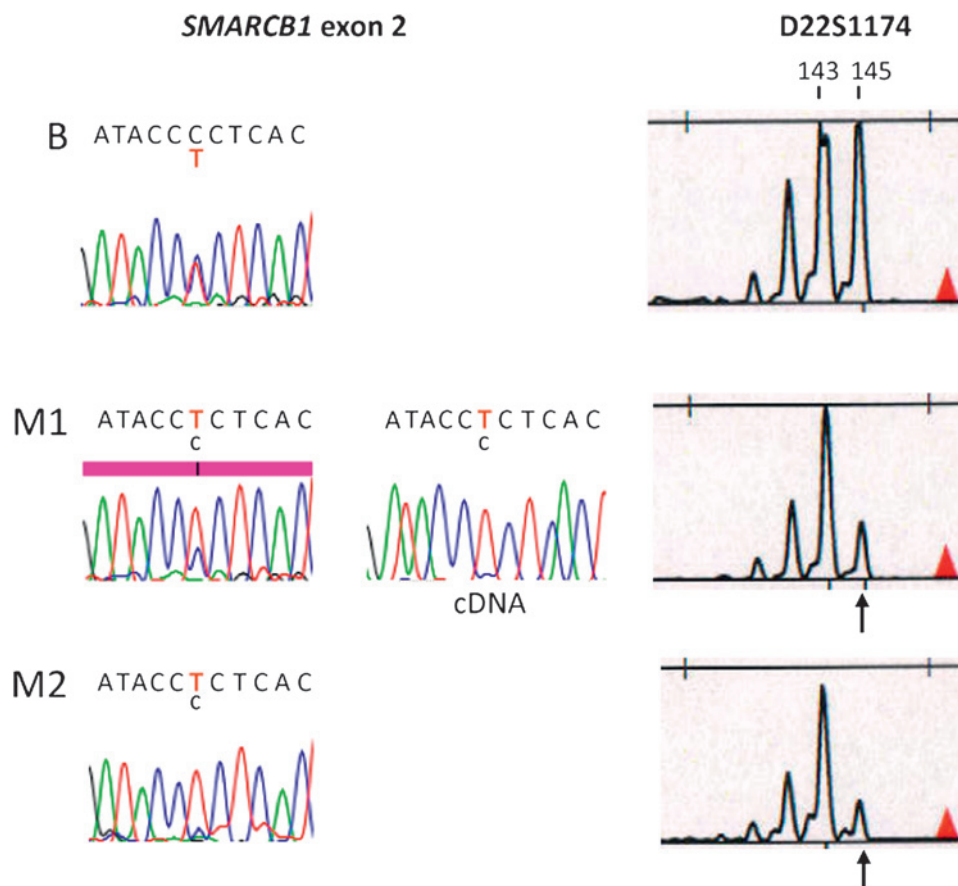

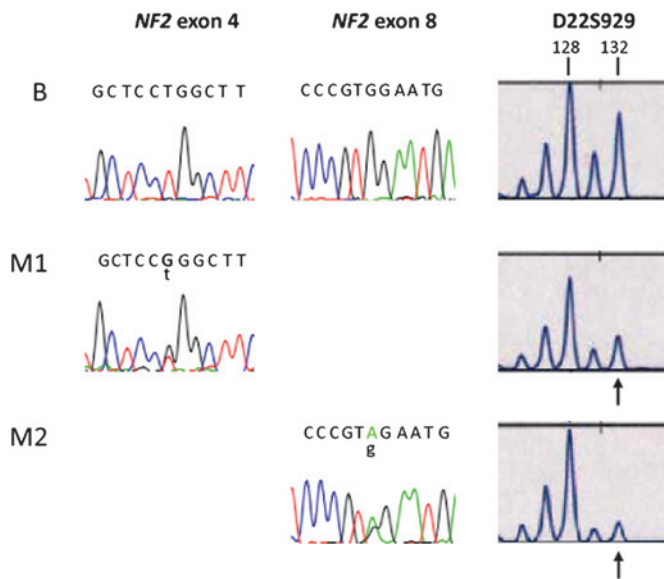

Figure 3 Sequence analysis of part of exons 4 and 8 of *NF2* and loss of heterozygosity (LOH) analysis with marker D22S929 in blood and meningioma of patient III-6. Left: presence of the mutant G allele in exon 4 in meningioma M1 DNA and the mutant A allele in exon 8 in meningioma M2 DNA, but absence of these mutant alleles in constitutional blood (B) DNA. Right: Presence of two alleles of marker D22S929 in blood DNA and considerable loss of the 132 bp allele, marked by arrow, in meningioma M1 and M2 DNA.

In addition, we performed multiple ligation dependent probe amplification (MLPA) analysis of the *NF2* gene in constitutional DNA of patient III-7. However, this analysis did not reveal any deletions or duplications.

DISCUSSION

We identified the germline mutation c.143C→T in *SMARCB1* that most probably predisposes to the development of multiple meningiomas. The mutation segregates with the presence of (multiple) meningiomas in this family and, in accordance with Knudson's two-hit hypothesis for tumorigenesis,²⁵ remains in the four investigated meningiomas, each with loss of the wild-type *SMARCB1* allele by LOH (figure 2). The causative nature of this missense mutation may be inferred from our in silico analyses, which demonstrated that the proline residue at position 48 is evolutionary conserved and that the change to leucine affects *SMARCB1* protein function and is probably damaging. The importance of proline at that position is furthermore supported by the finding of another missense mutation causing its replacement (c.142C→T, p.P48S) in a malignant rhabdoid tumour of the kidney.²⁶ Another missense mutation in the *SMARCB1* gene, c.92A→T, p.E31V, was recently identified as the predisposing genetic event in a family with schwannomatosis and multiple meningioma.²² RNA studies in whole blood of two patients in this family demonstrated absence of transcripts from the mutant *SMARCB1* allele. We, however, detected a stable transcript derived from the mutant *SMARCB1* allele that was retained in meningioma M1 of patient III-6 (figure 2). Accordingly, we found uniform staining of nuclei with a *SMARCB1* antibody (anti-BAF47) in all four meningiomas, suggesting that an intact *SMARCB1* protein was formed (data not shown).

The presence of a left sided cerebellopontine angle mass, probably a vestibular schwannoma, in patient II-6 and of multiple schwannomas in patient III-7 suggest that the *SMARCB1* mutation in this family may predispose to the

development of schwannomas as well. However, the vestibular schwannoma was diagnosed at age 56 and such a sporadic unilateral tumour is not uncommon at that age in the general population.²⁷ Unfortunately, the schwannomas were not available to further investigate the possible involvement of *SMARCB1*. A schwannoma analysed in the family with schwannomatosis and multiple meningiomas indeed displayed bi-allelic inactivation of *SMARCB1*.²² Two other schwannomatosis families, each with one patient developing one or two meningiomas, have been reported. However, the status of *SMARCB1* in these tumours was not investigated.^{16 17 28 29} Considering the frequent occurrence of meningiomas in the general population,¹ it cannot be excluded that their association with schwannomatosis in the latter families was coincidental. On the other hand, the missense mutation in *SMARCB1* in our family, affecting amino acid residue 48, and most probably also in the family presented by Bacci *et al*,²² affecting nearby amino acid residue 31, clearly predispose to the development of multiple meningiomas. Therefore, it is possible that the preference for meningioma development is, at least in part, determined by type and location of the *SMARCB1* mutation. Alternatively, the co-occurrence of schwannomas and meningiomas in some *SMARCB1* families and the sole occurrence of schwannomas in most other *SMARCB1* families may point to the existence of modifying genes segregating in these families and affecting the phenotypic expression of the *SMARCB1* mutation. Our finding, and that of Bacci *et al*,²² that meningiomas are part of the schwannomatosis tumour spectrum may require the diagnostic criteria for this disease be reconsidered. Further investigation of the possible association of type and location of the *SMARCB1* mutation and the development of multiple meningiomas and of possible modifying factors will require the identification and clinical evaluation of additional carriers of the mutated gene in our family and in other multiple meningiomas patients and families.

We identified additional independent somatic mutations in the *NF2* gene in the brain (M1) and spinal cord (M2) meningiomas of patient III-6 (figure 3). The missense mutation in exon 4 in meningioma M1 caused replacement of the evolutionary conserved leucine residue at position 141 in the *NF2* protein and its change into arginine affects, according to the in silico analyses, protein function and is probably damaging. The importance of leucine at position 141 is furthermore supported by the finding of another missense mutation causing its replacement (c.422T→C, p.L141P), which was reported as a constitutional *NF2* mutation in a patient with bilateral schwannomas.³⁰ The exon 8 mutation in meningioma M2 is a typical *NF2* nonsense mutation, causing truncation of the protein.³⁰ In accordance with Knudson's two-hit model, loss of the wild-type copy of *NF2* by LOH occurred in both tumours.²⁵ The finding of two causative hits (*NF2* mutation and deletion) in these meningiomas and our failure to detect a constitutional *NF2* mutation or deletion in the affected family members strongly argue against this gene as being the multiple meningioma predisposing gene in this family.

Summarising our data, we conclude that, analogous to the genetic events in a subset of schwannomatosis associated schwannomas,^{16–18} a four-hit mechanism of tumour suppressor gene inactivation, involving *SMARCB1* and *NF2*, might also be operative in familial multiple meningiomas associated meningiomas. In a recent study, no germline *SMARCB1* mutations were detected in 47 patients with multiple meningiomas, including eight familial cases.²³ Germline *SMARCB1* mutations are infrequently found in sporadic schwannomatosis patients

(<10% of cases). It is possible that, as in familial schwannomatosis (30–40% of cases), *SMARCB1* involvement is more frequent in familial multiple meningiomas. Alternatively, other genes might be implicated as predisposing genetic factors in both diseases.

Acknowledgements We thank the family members for their participation in this study. We are indebted to Dr D Troost (Neuropathology Department, Academic Medical Center, Amsterdam), Dr M G Havenith (Pathology Department, Isala Clinics, Zwolle), D Stomphorst (Pathology Department, Leiden University Medical Center, Leiden), and M Waaijer (Pathology Department, Medical Center Alkmaar, Alkmaar) for providing tumour materials.

Competing interests None.

Patient consent Obtained.

Provenance and peer review Not commissioned; externally peer reviewed.

REFERENCES

1. **Claus EB**, Bondy ML, Schildkraut JM, Wiemels JL, Wrensch M, Black PM. Epidemiology of intracranial meningioma. *Neurosurgery* 2005;**57**:1088–95.
2. **Evans DG**, Huson SM, Donnai D, Neary W, Blair V, Teare D, Newton V, Strachan T, Ramsden R, Harris R. A genetic study of type 2 neurofibromatosis in the United Kingdom. I. Prevalence, mutation rate, fitness, and confirmation of maternal transmission effect on severity. *J Med Genet* 1992;**29**:841–6.
3. **Parry DM**, Eldridge R, Kaiser-Kupfer MI, Bouzas EA, Pikus A, Patronas N. Neurofibromatosis 2 (NF2): clinical characteristics of 63 affected individuals and clinical evidence for heterogeneity. *Am J Med Genet* 1994;**52**:450–61.
4. **Mautner VF**, Lindenau M, Baser ME, Hazim W, Tatagiba M, Haase W, Samii M, Wais R, Pulst SM. The neuroimaging and clinical spectrum of neurofibromatosis 2. *Neurosurgery* 1996;**38**:880–5.
5. **Bijlsma EK**, Merel P, Bosch DA, Westerveld A, Delattre O, Thomas G, Hulsebos TJ. Analysis of mutations in the SCH gene in schwannomas. *Genes Chromosomes Cancer* 1994;**11**:7–14.
6. **Mérel P**, Hoang-Xuan K, Sanson M, Bijlsma E, Rouleau G, Laurent-Puig P, Pulst S, Baser M, Lenoir G, Sterkers JM, et al. Screening for germ-line mutations in the NF2 gene. *Genes Chromosomes Cancer* 1995;**12**:117–27.
7. **Lamszus K**, Vahldiek F, Mautner VF, Schichor C, Tonn J, Stavrou D, Fillbrandt R, Westphal M, Kluwe L. Allelic losses in neurofibromatosis 2-associated meningiomas. *J Neuropathol Exp Neurol* 2000;**59**:504–12.
8. **Nahser HC**, Grote W, Löhr E, Gerhard L. Multiple meningiomas. Clinical and computer tomographic observations. *Neuroradiology* 1981;**21**:259–63.
9. **Heinrich B**, Hartmann C, Stemmer-Rachamimov AO, Louis DN, MacCollin M. Multiple meningiomas: investigating the molecular basis of sporadic and familial forms. *Int J Cancer* 2003;**103**:483–8.
10. **Evans DG**, Watson C, King A, Wallace AJ, Baser ME. Multiple meningiomas: differential involvement of the NF2 gene in children and adults. *J Med Genet* 2005;**42**:45–8.
11. **Stangl AP**, Wellenreuther R, Lenartz D, Kraus JA, Menon AG, Schramm J, Wiestler OD, von Deimling A. Clonality of multiple meningiomas. *J Neurosurg* 1997;**86**:853–8.
12. **Zhu JJ**, Maruyama T, Jacoby LB, Herman JG, Gusella JF, Black PM, Wu JK. Clonal analysis of a case of multiple meningiomas using multiple molecular genetic approaches: pathology case report. *Neurosurgery* 1999;**45**:409–16.
13. **Eckstein O**, Stemmer-Rachamimov A, Nunes F, Hoch D, Ojemann R, MacCollin M. Multiple meningiomas in brain and lung due to acquired mutation of the NF2 gene. *Neurology* 2004;**62**:1904–5.
14. **Pulst SM**, Rouleau GA, Marineau C, Fain P, Sieb JP. Familial meningioma is not allelic to neurofibromatosis 2. *Neurology*, 1993;**43**:2096–8.
15. **Hulsebos TJ**, Plomp AS, Wolterman RA, Robanus-Maandag EC, Baas F, Wesseling P. Germline mutation of INI1/SMARCB1 in familial schwannomatosis. *Am J Hum Genet* 2007;**80**:805–10.
16. **Boyd C**, Smith MJ, Kluwe L, Balogh A, Maccollin M, Plotkin SR. Alterations in the SMARCB1 (INI1) tumor suppressor gene in familial schwannomatosis. *Clin Genet* 2008;**74**:358–66.
17. **Hadfield KD**, Newman WG, Bowers NL, Wallace A, Bolger C, Colley A, McCann E, Trump D, Prescott T, Evans DG. Molecular characterisation of SMARCB1 and NF2 in familial and sporadic schwannomatosis. *J Med Genet* 2008;**45**:332–9.
18. **Sestini R**, Bacci C, Provenzano A, Genuardi M, Papi L. Evidence of a four-hit mechanism involving SMARCB1 and NF2 in schwannomatosis-associated schwannomas. *Hum Mutat* 2008;**29**:227–31.
19. **Bruder CE**, Dumanski JP, Kedra D. The mouse ortholog of the human SMARCB1 gene encodes two splice forms. *Biochem Biophys Res Commun* 1999;**257**:886–90.
20. **Schmitz U**, Mueller W, Weber M, Sévenet N, Delattre O, von Deimling A. INI1 mutations in meningiomas at a potential hotspot in exon 9. *Br J Cancer* 2001;**84**:199–201.
21. **Rieske P**, Zakrzewska M, Piaskowski S, Jaskólski D, Sikorska B, Papier W, Zakrzewski K, Liberski PP. Molecular heterogeneity of meningioma with INI1 mutation. *Mol Pathol* 2003;**56**:299–301.
22. **Bacci C**, Sestini R, Provenzano A, Paganini I, Mancini I, Porfirio B, Vivarelli R, Genuardi M, Papi L. Schwannomatosis associated with multiple meningiomas due to a familial SMARCB1 mutation. *Neurogenetics* 2010;**11**:73–80.
23. **Hadfield KD**, Smith MJ, Trump D, Newman WG, Evans DG. SMARCB1 mutations are not a common cause of multiple meningiomas. *J Med Genet* 2010;**47**:567–8.
24. **Legoux P**, Legrand MF, Ollagnon E, Lenoir G, Thomas G, Zucman-Rossi J. Characterisation of 16 polymorphic markers in the NF2 gene: application to hemizyosity detection. *Hum Mutat* 1999;**13**:290–3.
25. **Knudson AG Jr**. Mutation and cancer: statistical study of retinoblastoma. *Proc Natl Acad Sci U S A* 1971;**68**:820–3.
26. **Sévenet N**, Lellouch-Tubiana A, Schofield D, Hoang-Xuan K, Gessler M, Birnbaum D, Jeanpierre C, Jouvret A, Delattre O. Spectrum of hSNF5/INI1 somatic mutations in human cancer and genotype-phenotype correlations. *Hum Mol Genet* 1999;**8**:2359–68.
27. **Baser ME**, Friedman JM, Evans DG. Increasing the specificity of diagnostic criteria for schwannomatosis. *Neurology* 2006;**66**:730–2.
28. **Evans DG**, Mason S, Huson SM, Ponder M, Harding AE, Strachan T. Spinal and cutaneous schwannomatosis is a variant form of type 2 neurofibromatosis: a clinical and molecular study. *J Neurol Neurosurg Psychiatry* 1997;**62**:361–6.
29. **MacCollin M**, Willett C, Heinrich B, Jacoby LB, Acierno JS Jr, Perry A, Louis DN. Familial schwannomatosis: exclusion of the NF2 locus as the germline event. *Neurology* 2003;**60**:1968–74.
30. **Ahronowitz I**, Xin W, Kiely R, Sims K, MacCollin M, Nunes FP. Mutational spectrum of the NF2 gene: a meta-analysis of 12 years of research and diagnostic laboratory findings. *Hum Mutat* 2007;**28**:1–12.



Germline *SMARCB1* mutation and somatic *NF2* mutations in familial multiple meningiomas

I Christiaans, S B Kenter, H C Brink, et al.

J Med Genet 2011 48: 93-97 originally published online October 7, 2010

doi: 10.1136/jmg.2010.082420

Updated information and services can be found at:

<http://jmg.bmj.com/content/48/2/93.full.html>

These include:

References

This article cites 30 articles, 12 of which can be accessed free at:

<http://jmg.bmj.com/content/48/2/93.full.html#ref-list-1>

Article cited in:

<http://jmg.bmj.com/content/48/2/93.full.html#related-urls>

Email alerting service

Receive free email alerts when new articles cite this article. Sign up in the box at the top right corner of the online article.

Topic Collections

Articles on similar topics can be found in the following collections

[CNS cancer](#) (37 articles)

[Neurooncology](#) (69 articles)

[Molecular genetics](#) (1086 articles)

Notes

To request permissions go to:

<http://group.bmj.com/group/rights-licensing/permissions>

To order reprints go to:

<http://journals.bmj.com/cgi/reprintform>

To subscribe to BMJ go to:

<http://group.bmj.com/subscribe/>