



## UvA-DARE (Digital Academic Repository)

### Creatine kinase and blood pressure: Clinical and therapeutic implications

Oudman, I.

**Publication date**  
2013

[Link to publication](#)

#### **Citation for published version (APA):**

Oudman, I. (2013). *Creatine kinase and blood pressure: Clinical and therapeutic implications*. [Thesis, fully internal, Universiteit van Amsterdam].

#### **General rights**

It is not permitted to download or to forward/distribute the text or part of it without the consent of the author(s) and/or copyright holder(s), other than for strictly personal, individual use, unless the work is under an open content license (like Creative Commons).

#### **Disclaimer/Complaints regulations**

If you believe that digital publication of certain material infringes any of your rights or (privacy) interests, please let the Library know, stating your reasons. In case of a legitimate complaint, the Library will make the material inaccessible and/or remove it from the website. Please Ask the Library: <https://uba.uva.nl/en/contact>, or a letter to: Library of the University of Amsterdam, Secretariat, Singel 425, 1012 WP Amsterdam, The Netherlands. You will be contacted as soon as possible.

# Chapter 2

Healthy men with high serum CK activity  
display reduced sodium excretion  
after a high salt diet

I. Oudman  
I. Khoyska  
L. M. Brewster

*Submitted*

## ABSTRACT

**Background** Serum creatine kinase (CK) was reported to be the main predictor of blood pressure in the general population, with an increase in SBP and DBP of resp. 14 and 8 mm Hg per log CK increase. The enzyme is tightly bound near  $\text{Na}^+/\text{K}^+$ -ATPase in the kidney, where it rapidly regenerates ATP for tubular sodium reabsorption. Therefore, we hypothesized that sodium excretion is reduced in subjects with high serum CK activity.

**Method** Eligible for inclusion were healthy men with normotension or untreated hypertension, younger than 50 years, on 7 days of low sodium (<50 mmol/d) followed by 3 days of high sodium (>200 mmol/d). Examination included sitting resting blood pressure, serum CK after rest, and sodium, potassium, and creatinine in serum and 24-h urine. After correlation analysis, we assessed the difference in sodium excretion after a high salt diet between the lowest and the highest CK tertile.

**Results** We included 52 subjects, 27 white and 25 black, with a mean age of 37.0 (SE 1.4) y and mean BMI of 24.7(0.4)  $\text{kg}/\text{m}^2$ . Median serum CK activity was 205.0 IU/L (Range, 63 to 1648 IU/L). After logarithmic transformation, serum CK was negatively correlated with 24-h urinary sodium excretion after a high salt diet; a correlation coefficient of -0.40 ( $p=0.002$ ). Sodium excretion after a high salt diet was significantly lower in the highest compared to the lowest log CK tertile; respectively 279.6 (34.1) versus 403.9 (25.5) mmol/day ( $p=0.007$ ).

**Discussion** Subjects with high CK activity display reduced sodium excretion after a high salt diet. Under the assumption that serum CK reflects tissue CK, this may imply that high CK activity promotes sodium reabsorption in the renal tubules, as the enzyme regenerates ATP near  $\text{Na}^+/\text{K}^+$ -ATPase, the primary force for tubular sodium transport.

## BACKGROUND

Salt plays a major role in the regulation of blood pressure and an extensive amount of evidence links higher salt intake with higher blood pressures and increased cardiovascular risk.<sup>1-3</sup> There is a wide interindividual variability in sensitivity to changes in salt balance.<sup>4</sup> Salt sensitivity is associated with increased cardiovascular risk and mortality in hypertensive and normotensive subjects.<sup>4,5</sup> However, the pathophysiological mechanism leading to sodium retention in some individuals, whereas others exposed to the same intake are able to excrete sodium, has not yet been defined.

We propose that differences in activity of the enzyme creatine kinase (CK) may be related to differences in sodium handling.<sup>6,7</sup> By catalyzing the reversible transfer of a phosphate group from phosphocreatine to ADP, the enzyme connects sites of ATP production (glycolysis and mitochondrial oxidative phosphorylation) with subcellular sites of ATP utilization, including myosin ATPase and myosin light chain kinase at the contractile proteins and  $\text{Ca}^{2+}$ -ATPase and  $\text{Na}^+/\text{K}^+$ -ATPase at cellular membranes, where it rapidly regenerates ATP in situ from phosphocreatine.<sup>6,8,9</sup> In this way, the enzyme is thought to lead to greater ATP buffer capacity for cardiovascular contractility and renal sodium retention.<sup>6,7</sup> In line with this, serum CK was found to be the main predictor of blood pressure in the population, independent of age, sex, BMI, or ethnicity, with an increase in systolic and diastolic blood pressure of resp. 14 and 8 mm Hg per log CK increase.<sup>7,10</sup>

In the kidney, sodium reabsorption is primarily driven by basolateral  $\text{Na}^+/\text{K}^+$ -ATPase, coupling hydrolysis of ATP to the active exchange of three intracellular  $\text{Na}^+$  ions for two  $\text{K}^+$  ions. CK is tightly bound near this enzyme, where it regenerates ATP for tubular sodium reabsorption. High CK activity near this enzyme may thus enhance ATP availability for this highly energy demanding process (Figure 1).<sup>11,12</sup> Therefore, we hypothesized that sodium excretion is reduced in subjects with high CK activity.

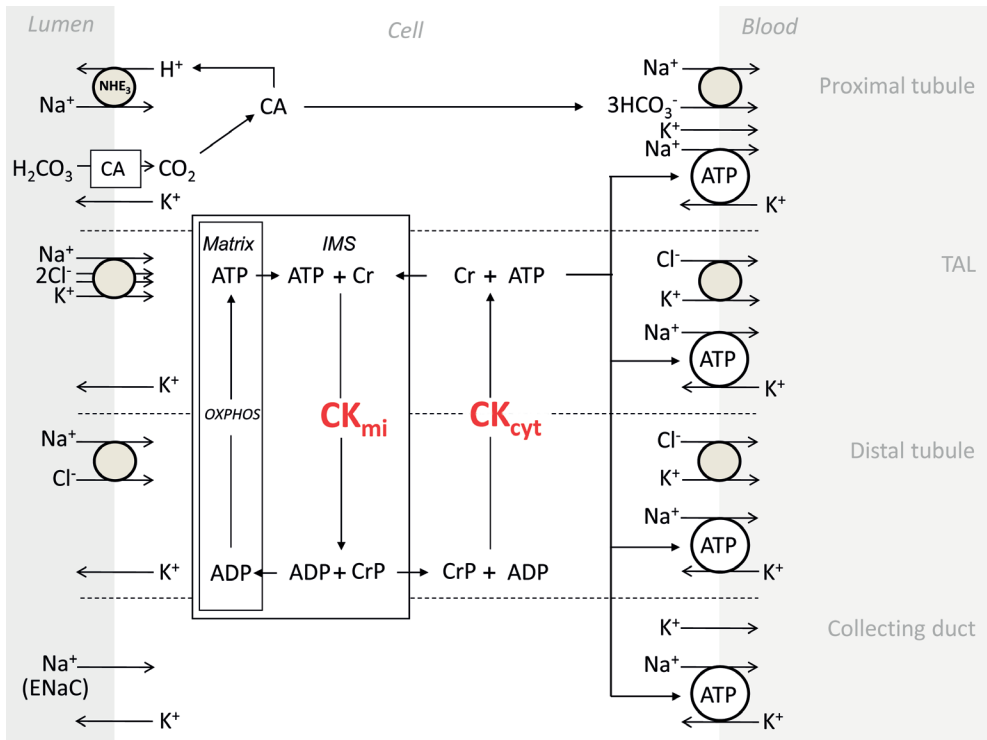

**Figure 1. Mechanism of sodium reabsorption in the kidney.**

Basic mechanisms of sodium transport in the proximal tubule, thick ascending limb, distal tubule, and collecting duct, modified from Greger et al.<sup>11</sup> In all parts of the nephron, basolateral  $\text{Na}^+/\text{K}^+$ -ATPase is the primary force for the vectorial transport of sodium from the tubular lumen to the blood compartment,<sup>24</sup> by coupling hydrolysis of ATP to the active exchange of three intracellular  $\text{Na}^+$  ions for two  $\text{K}^+$  ions.<sup>11</sup> Evidence indicates that creatine kinase (CK) is functionally coupled to renal  $\text{Na}^+/\text{K}^+$ -ATPase and that ATP produced by colocalized CK is preferentially used for the high and fluctuating ATP demand of sodium transport across the tubular epithelial cells.<sup>18-21</sup> Both mitochondrial and the cytosolic B isoform of CK have been found in mammalian kidney.<sup>17,26</sup> NHE3,  $\text{Na}^+/\text{H}$  exchanger; CA, carbonic anhydrase; CK, creatine kinase; Cr, creatine; CrP, phosphocreatine; ENaC, epithelial sodium channel; matrix, mitochondrial matrix; IMS, mitochondrial intermembrane space; TAL, thick ascending limb.

## METHODS

### Participants and protocol

The protocol was approved by our local institutional review board. All of the procedures were in accordance with institutional guidelines. All participants gave written informed consent. We included healthy men, normotensive or with untreated

primary hypertension, of self reported white or black ethnicity. Subjects with treated or secondary hypertension, glucose, lipid spectrum, thyroid, kidney, or liver abnormalities, CK-increasing drugs including statins, cardiovascular, neuromuscular, or endocrine disorders, vasculitis, HIV infection, or infectious hepatitis were excluded. Participants were instructed to abstain from heavy exercise three days before the baseline visit to our hospital. Physical examination was unremarkable. After the baseline visit, subjects were instructed to adhere to a low sodium diet (50 mmol Na<sup>+</sup> per day, LS) during 7 days followed by a high sodium diet (>200 mmol Na<sup>+</sup> per day, HS) during 3 days. During HS a minimal daily amount of sodium (200 mmol) was provided to the participants by the research physician. A dietician was consulted before start of the protocol. During the study, participants were supported daily by the research physician. At baseline, day 1, and day 4 of LS overnight urine was sampled to assess dietary compliance. At the final day of each level of sodium intake all participants collected 24-h urine, and, after an overnight fast, body weight and blood pressure was measured, and blood were sampled.

### **Study measures**

Physical examination included height, weight, and blood pressure levels. Office blood pressure was measured with an Omron M4 oscillometric device (Omron Healthcare Europe BV, Hoofddorp, the Netherlands). In a quiet room with the subject seated following a 5-minute rest period. An appropriately adjusted cuff size was used on the non-dominant arm, supported at heart level. Blood pressure was calculated as the mean of the second and third reading, with a maximum of 5 mm Hg difference.<sup>13</sup> Body mass index (BMI) was calculated as weight (kg) divided by the height (rounded to the nearest centimeter) squared. Laboratory studies included serum CK activity after 3 days of rest, creatinine, sodium, potassium, urea, fasting glucose, fasting lipids, including total cholesterol, low-density lipoprotein (LDL), high-density lipoprotein (HDL), and triglycerides. Urine analysis included sodium, potassium, creatinine, and urea. All laboratory analyses were performed on a Modular Cobas 8000 (Roche Diagnostics, Darmstadt, Germany). Plasma levels of CK, glucose, total cholesterol and triglycerides were estimated by enzymatic spectrophotometric; high-density lipoprotein – cholesterol by colorimetric/spectrophotometric; plasma creatinine and urea by kinetic/spectrophotometric; and sodium and potassium by Indirect Ion-Selective Electrode methods.

## Data analysis and statistics

The primary outcome was the difference in 24-h urinary sodium excretion after a high salt diet between the lowest and the highest serum CK tertile. Other outcomes included correlations of 24-h sodium excretion after high salt with serum CK, age, and BMI, and ethnic differences in sodium excretion. Finally, we assessed whether correction for 24-h creatinine excretion, as a measure of the accuracy of sampling, influenced the outcomes.

Based on previously reported differences in sodium excretion of 10-50% between salt sensitives and controls,<sup>14</sup> we calculated to need 40 subjects to detect this difference with a one-sided alpha of 0.05 and a 1-beta of 0.80. Because serum CK distribution was expected to be extremely skewed to the right, a logarithmic transformation to base 10 was performed to achieve a more symmetrical distribution. For statistical analysis, unpaired and paired t-tests were used for between group (low vs high CK tertile, white vs black ethnicity) and within-group (HS effect) comparisons respectively. To assess associations, 1-tailed Spearman's rank correlations were calculated for 24-hour urinary sodium excretion versus log serum CK, age, and BMI.

We considered a one-sided probability value of <0.05 to be significant. Data were analyzed with SPSS statistical software package for Windows, version 19.0 (SPSS Inc., Chicaco, IL, USA). Data are presented as mean with the standard error in square brackets unless stated otherwise.

**Table 1. Baseline characteristics of the participants.**

Participants	Total* (n=52)	White (n=27)	Black (n=25)
Age (y) <sup>†</sup>	37.0 (1.4)	33.7 (1.7)	40.6 (2.0)
BMI (kg/m <sup>2</sup> ) <sup>†</sup>	24.7(0.4)	23.7 (0.5)	25.8 (3.4)
CK (IU/L) <sup>‡§</sup>	205.0 (63.0 to 1648.0)	132.0 (63.0 to 680.0)	319.0 (116.0 to 1648.0)
Creatinine (μmol/L) <sup>†§</sup>	96.4 (1.6)	92.8 (2.1)	100.3 (2.4)
SBP (mm Hg) <sup>†</sup>	125.6(1.8)	122.8 (2.0)	128.7 (3.0)
DBP (mm Hg) <sup>†</sup>	76.8(1.4)	74.7 (1.8)	79.0 (2.0)
Hypertension (N)	8	2	6
Cholesterol(mmol/L) <sup>†§</sup>	4.8 (0.1)	4.9 (0.2)	4.8 (0.1)
Glucose (mmol/L) <sup>†§</sup>	5.5 (0.1)	5.4 (0.1)	5.6 (0.1)

BMI, body mass index; SBP, DBP, systolic/diastolic blood pressure; Hypertension, systolic/diastolic blood pressure ≥140/90 mm Hg; CK, serum creatine kinase after 3 days of rest; \* Includes participants with "other" ethnicity (n=5); <sup>†</sup> Mean (SE); <sup>‡</sup> Median (Range); <sup>§</sup> fasting plasma concentration

## RESULTS

Fifty-two men, including 27 white and 25 black, were included, with a mean age of 37.0(1.4) y and mean BMI of 24.7(0.4) kg/m<sup>2</sup>. Mean systolic/diastolic blood pressure (SBP/DBP) was 125.6(1.8)/ 76.8(1.4) mm Hg. Eight subjects were hypertensive (SBP/DBP ≥140/90 mm Hg). The baseline characteristics of the included participants are shown in Table 1. Crude CK activities ranged from 63.0 to 1648.0 IU/L (Median, 205.0 IU/L). We identified one possible outlier (1648 IU/L, black ethnicity), and after applying Dixon's one-third rule, this subject was excluded from further analysis. As the data still showed significant skewness and kurtosis, a logarithmic transformation was performed to acquire a normal distribution.

General parameters during LS and HS are shown in Table 2. Mean 24-h urinary sodium excretion during LS and HS was 28.1 (3.1) and 328.0 (23.0) mmol/day respectively ( $p<0.001$ ), indicating an adequate dietary compliance. Mean body weight and SBP increased significantly during HS, as expected, whereas DBP was not significantly changed. The 24-h urinary creatinine, potassium, and urea excretion were higher during HS.

**Table 2. General parameters during low and high sodium diet (N=52).**

Parameter	Low sodium	High sodium	P-value
Body weight (kg)	79.1 (1.6)	81.0 (1.6)	<0.001
SBP (mm Hg)	120.9 (1.4)	124.6 (1.5)	<0.001
DBP (mm Hg)	73.7 (1.0)	74.4 (1.1)	0.353
Heart Rate	66.3 (1.5)	60.7 (1.4)	<0.001
Urinary sodium excretion (mmol/day)	28.1 (3.1)	328.0 (23.0)	<0.001
Urinary creatinine excretion (mmol/day)	14.1 (0.6)	15.8 (0.9)	0.036
Urinary potassium excretion (mmol/day)	68.9 (4.5)	77.7 (5.3)	0.079
Urinary urea excretion (mmol/day)	308.9 (19.0)	387.3 (20.7)	<0.001
Plasma sodium (mmol/L)	139.9 (0.2)	142.1 (0.2)	<0.001
Plasma potassium (mmol/L)	4.12 (0.04)	4.08 (0.03)	0.208
Plasma creatinine (μmol/L)	97.5 (1.8)	92.4 (1.5)	0.001

SBP, DBP, systolic/diastolic blood pressure; All values are mean (SE).



After logarithmic transformation, we found a negative correlation between serum CK and 24-h urinary sodium excretion after a high salt diet, with a correlation coefficient of  $-0.40$  ( $p=0.002$ ). Subsequently, we assessed differences between the lowest and highest CK tertile. Parameters during LS and HS for the first and the third CK tertile are shown in Table 3. The highest tertile included more black men, as expected.<sup>15</sup> Sodium excretion after a high salt diet was significantly lower in the highest compared to the lowest log CK tertile; respectively 279.6 (34.1) versus 403.9 (25.5) mmol/day ( $p=0.007$ ) (Figure 2). In addition, the urinary 24-h potassium excretion was significantly lower in the highest CK tertile.

**Table 3. Parameters during low and high sodium in the lowest versus the highest log CK tertile.**

Parameter	Tertile I (N=17)	Tertile III (N=16)	P-value
Age	35.7 (2.5)	35.5 (2.4)	0.973
BMI	23.6 (0.6)	25.8 (0.9)	0.053
Black ethnicity (%)	17.6	76.5	0.001
Sodium excretion (mmol/day)			
LS	27.9 (4.9)	25.5 (4.4)	0.0543
HS	403.9 (105.3)	279.6 (34.1)	0.007
Creatinine excretion (mmol/day)			
LS	15.4 (1.0)	13.1 (0.8)	0.089
HS	18.3 (2.1)	14.9 (0.84)	0.145
Potassium excretion (mmol/day)			
LS	90.4 (7.9)	60.1 (6.3)	0.005
HS	100.5 (10.7)	63.9 (6.8)	0.008
Systolic blood pressure (mm Hg)			
LS	119.3 (2.7)	121.8 (2.6)	0.778
HS	124.8 (3.1)	124.1 (2.6)	0.630
Diastolic blood pressure (mm Hg)			
LS	75.0 (1.8)	73.4 (1.5)	0.464
HS	74.7 (1.7)	73.7 (1.7)	0.448

LS, low sodium diet; HS, high sodium diet; All values are mean (SE)

In line with previous reports on ethnic differences in sodium handling,<sup>14,16</sup> the 24-h urinary sodium excretion during HS was lower in blacks compared to whites, the 24-h urinary sodium excretion during HS was lower in black compared to white men, 213.4 (24.3) and 434.2 (24.2) mmol/day respectively ( $p<0.001$ ). The 24-h potassium excretion was 58.8 (6.8) and 95.0 (6.5) mmol/day for black and white men respectively. Correlation coefficients for age and BMI with 24-h sodium excretion were -0.30 ( $p=0.014$ ) and -0.12 ( $p=0.203$ ). Correction for 24-h creatinine excretion, as a measure for urine sampling accuracy, had no major influence on the direction and magnitudes of the outcomes.

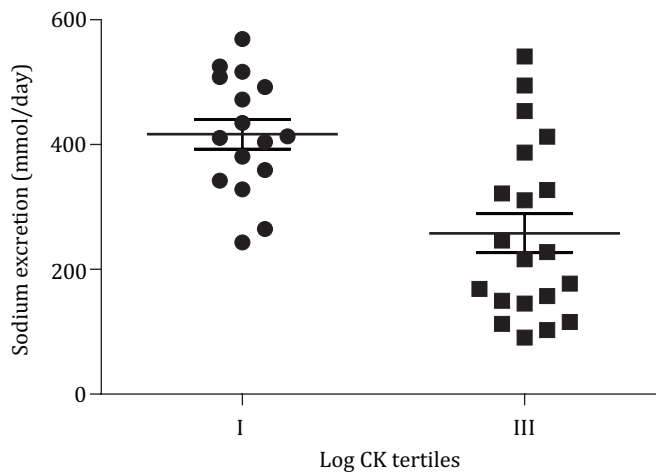

**Figure 2. Urinary sodium excretion after a high salt diet in the lowest and the highest creatine kinase tertile.**

The 24 h urinary sodium excretion after a high salt diet is shown for the lowest (N=17) and the highest (N=17) log creatine kinase (CK) tertile. Sodium excretion was significantly higher in the lowest compared to the highest tertile ( $p<0.001$ ).

## DISCUSSION

In this study we report for the first time that serum CK is associated with urinary sodium excretion after a high salt diet. This may imply that CK has a contribution to sodium reabsorption in the renal tubules (Figure 1). In the kidney,  $\text{Na}^+/\text{K}^+$ -ATPase is the primary force for regulating sodium handling and plays a key role in both ion homeostasis and

blood pressure regulation.<sup>12,17,18</sup> Evidence indicates that CK is functionally coupled to renal  $\text{Na}^+/\text{K}^+$ -ATPase and that ATP produced by colocalized CK is preferentially used for the high and fluctuating ATP demand of sodium transport across the tubular epithelial cells.<sup>19-22</sup> Thus, high CK activity in the kidney tubule cells may lead to increased availability of ATP for the active process of sodium reabsorption. This process is achieved by tight cooperation of exchangers, transporters, and ion channels in the nephron.<sup>23</sup> Proximal tubule sodium handling accounts for 60-70% of reabsorption of all filtered sodium, 20 to 30% of the filtered load is absorbed in the thick ascending loop of Henle, and 5 to 10% in the distal tubule.<sup>11,24</sup> Importantly, in all parts of the nephron,  $\text{Na}^+/\text{K}^+$ -ATPase resides at the basolateral surface, where it provides the force for the vectorial transport of sodium from the tubular lumen to the blood compartment,<sup>25</sup> by coupling hydrolysis of ATP to the active exchange of three intracellular  $\text{Na}^+$  ions for two  $\text{K}^+$  ions.<sup>11</sup>

In the absence of tissue damage, serum CK at rest is thought to reflect tissue CK activity. In the mammalian kidney, both the cytosolic B isoform and a mitochondrial form of CK have been found.<sup>18,26</sup> Healthy tissue loses a small fraction of intracellular CK into the interstitial space, which is transported to the bloodstream via the lymphatic system. This release is proportional to tissue CK activity.<sup>27,28</sup> Therefore, as the high CK state is a generalized condition, high serum CK activity may partly reflect high renal CK activity.

Our findings are in accord with previous studies showing that serum CK was the main predictor of systolic and diastolic blood pressure in the population, independent of age, BMI, sex, and ethnicity.<sup>7,10</sup> Regarding the effect of sodium retention on blood pressure, sodium and commensurate water induce an expansion of intravascular fluid volume, leading to an increase in cardiac output, that alone was primarily thought by some to initiate the pressor effect of salt.<sup>23,29</sup> However, it was shown in salt sensitive but not salt resistant subjects that the increase in cardiac output with dietary salt loading was accompanied by inhibition of normal vasodilatation.<sup>30,31</sup> Thus, vascular dysfunction with increased peripheral resistance is thought to be critical to the initiation of pressor responses to dietary salt loading.<sup>30</sup> We previously found that patients with relatively high serum CK had greater vascular contractility *in vitro*, and that CK inhibition reduced contractility.<sup>32</sup> Therefore, the high CK phenotype, including high renal CK and high vascular CK may augment the vasodilatory response to volume expansion with dietary salt loading.

Relatively high tissue and serum CK activity is found in black people.<sup>15,33,34</sup> Black people are known to have a reduced ability to excrete sodium.<sup>14</sup> This is accompanied by lower potassium excretion and higher urine concentration, whereas levels of renin are, on average, lower in blacks than whites.<sup>35,36</sup> The reduced capacity of the kidney to excrete sodium is thought to play a major role in the greater prevalence of (salt-sensitive) hypertension this population subgroup.<sup>16,37,38</sup> The findings of this study are in line, as we reported reduced sodium and potassium excretion after a high salt diet in blacks compared to whites. Besides the relatively reduced ability to excrete sodium, evidence indicates that blacks have enhanced vascular reactivity to sympathetic stimulation, attenuated responses to vasodilators, in particular due to reduced nitric oxide availability, and a relatively narrow vascular lumen diameter.<sup>39</sup> However, despite extensive research, the pathophysiological mechanism underlying enhanced sodium retention and hypercontractility of the vasculature in black people is not completely understood. The results from this study combined with previous reports may suggest that a genetically determined high CK phenotype, including high renal and cardiovascular CK, underlies the greater tendency of black people for sodium retention and attenuated vasodilatory responses, leading to a greater burden of hypertension and its associated cardiovascular morbidity and mortality in this population subgroup.<sup>40,41</sup>

This study has several strengths and limitations. The main strength is that we were able to show for the first time that healthy men with high serum CK activity excrete less sodium on a high salt diet. Furthermore, we standardised for exercise. Serum CK activity is elevated up to 3 days with regular exercise, and up to a week after strenuous eccentric exercise, where the muscle lengthens and contracts at the same time against an external load. This leads to disruption of muscle fibers, and highly elevated serum CK, up to 10.000 IU/L during a week or longer.<sup>42</sup> However, none of the participants stated to be involved in such eccentric exercise. Still, we cannot exclude an exercise induced component in the CK values. Third, during the diet the participants were closely monitored and supported by the research physician and during HS the minimal daily amount of sodium (200 mmoles) was provided to the participants. However, as the monitoring of sodium intake in a real life setting is difficult, we cannot exclude that the dietary intake of sodium during HS was below the target of minimally 200 mmoles sodium per day.

A limitation is that we were not able stratify for ethnicity, as most subjects with high CK activity were black, in line with the distribution of serum and tissue CK in the population.<sup>15</sup> However, we provide a biologically plausible mechanism for the reduced

ability of black people to excrete sodium, as skin colour per se does not explain the observed ethnic differences. Another limitation is the use of serum CK as an indirect measure of the renal CKB isoform. Although serum CK is known to reflect tissue CK, is not clear whether this accurately reflects CK activity in the kidney. Therefore, further studies should assess renal CK activity in relation to sodium handling.

In summary, we showed that subjects with high CK activity display reduced urinary sodium excretion after a high salt diet. Under the assumption that serum CK reflects tissue CK, this may imply that high CK activity promotes sodium reabsorption in the renal tubules, as CK regenerates ATP near  $\text{Na}^+/\text{K}^+$ -ATPase, which provides the primary force for tubular sodium transport. Our findings support the hypothesis that the high CK phenotype is hypertension prone, through greater ATP buffer capacity for cardiovascular contractility as well as sodium retention in the kidney.

## REFERENCES

1. Reuter S, Bussemaker E, Hausberg M, Pavenstadt H, Hillebrand U. Effect of excessive salt intake: role of plasma sodium. *Curr Hypertens Rep* 2009;11:91-7.
2. Ezzati M, Lopez AD, Rodgers A, Vander HS, Murray CJ. Selected major risk factors and global and regional burden of disease. *Lancet* 2002;360:1347-60.
3. Meneton P, Jeunemaitre X, de Wardener HE, MacGregor GA. Links between dietary salt intake, renal salt handling, blood pressure, and cardiovascular diseases. *Physiol Rev* 2005;85:679-715.
4. Weinberger MH, Fineberg NS, Fineberg SE, Weinberger M. Salt sensitivity, pulse pressure, and death in normal and hypertensive humans. *Hypertension* 2001;37:429-32.
5. Morimoto A, Uzu T, Fujii T et al. Sodium sensitivity and cardiovascular events in patients with essential hypertension. *Lancet* 1997;350:1734-7.
6. Brewster LM, Clark JF, van Montfrans GA. Is greater tissue activity of creatine kinase the genetic factor increasing hypertension risk in black people of sub-Saharan African descent? *J Hypertens* 2000;18:1537-44.
7. Brewster LM, Mairuhu G, Bindraban NR, Koopmans RP, Clark JF, van Montfrans GA. Creatine kinase activity is associated with blood pressure. *Circulation* 2006;114:2034-9.
8. Dzeja PP, Terzic A. Phosphotransfer networks and cellular energetics. *J Exp Biol* 2003;206:2039-47.
9. Wallimann T, Dolder M, Schlattner U et al. Some new aspects of creatine kinase (CK): compartmentation, structure, function and regulation for cellular and mitochondrial bioenergetics and physiology. *Biofactors* 1998;8:229-34.
10. Johnsen SH, Lilleng H, Wilsaard T, Bekkelund SI. Creatine kinase activity and blood pressure in a normal population: the Tromso study. *J Hypertens* 2011;29:36-42.
11. Greger R. Physiology of renal sodium transport. *Am J Med Sci* 2000;319:51-62.
12. Ikeda K. Localization of brain type creatine kinase in kidney epithelial cell subpopulations in rat. *Experientia* 1988;44:734-5.
13. Mansia G, De BG, Dominiczak A et al. 2007 ESH-ESC Guidelines for the management of arterial hypertension: the task force for the management of arterial hypertension of the European Society of Hypertension (ESH) and of the European Society of Cardiology (ESC). *Blood Press* 2007;16:135-232.
14. Brier ME, Luft FC. Sodium kinetics in white and black normotensive subjects: possible relevance to salt-sensitive hypertension. *Am J Med Sci* 1994;307 Suppl 1:S38-S42.
15. Brewster LM, Coronel CM, Sluiter W, Clark JF, van Montfrans GA. Ethnic differences in tissue creatine kinase activity: an observational study. *PLoS One* 2012;7:e32471.
16. Luft FC, Miller JZ, Grim CE et al. Salt sensitivity and resistance of blood pressure. Age and race as factors in physiological responses. *Hypertension* 1991;17:1102-1108.
17. Guerrero ML, Beron J, Spindler B, Groscurth P, Wallimann T, Verrey F. Metabolic support of Na<sup>+</sup> pump in apically permeabilized A6 kidney cell epithelia: role of creatine kinase. *Am J Physiol* 1997;272:C697-C706.
18. Friedman DL, Perryman MB. Compartmentation of multiple forms of creatine kinase in the distal nephron of the rat kidney. *J Biol Chem* 1991;266:22404-10.
19. Blum H, Balschi JA, Johnson RG, Jr. Coupled in vivo activity of creatine phosphokinase and the membrane-bound (Na<sup>+</sup>,K<sup>+</sup>)-ATPase in the resting and stimulated electric organ of the electric fish *Narcine brasiliensis*. *J Biol Chem* 1991;266:10254-9.

20. Saks VA, Lipina NV, Sharov VG, Smirnov VN, Chazov E, Grosse R. The localization of the MM isozyme of creatine phosphokinase on the surface membrane of myocardial cells and its functional coupling to ouabain-inhibited (Na<sup>+</sup>, K<sup>+</sup>)-ATPase. *Biochim Biophys Acta* 1977;465:550-8.
21. Kultz D, Somero GN. Ion transport in gills of the euryhaline fish *Gillichthys mirabilis* is facilitated by a phosphocreatine circuit. *Am J Physiol* 1995;268:R1003-R1012.
22. Wallimann T, Hemmer W. Creatine kinase in non-muscle tissues and cells. *Mol Cell Biochem* 1994;133-134:193-220.
23. Lifton RP, Gharavi AG, Geller DS. Molecular mechanisms of human hypertension. *Cell* 2001;104:545-56.
24. de Wardener HE. The control of sodium excretion. *Am J Physiol* 1978;235:F163-F173.
25. Caplan MJ. Ion pumps in epithelial cells: sorting, stabilization, and polarity. *Am J Physiol* 1997;272:G1304-G1313.
26. Payne RM, Haas RC, Strauss AW. Structural characterization and tissue-specific expression of the mRNAs encoding isoenzymes from two rat mitochondrial creatine kinase genes. *Biochim Biophys Acta* 1991;1089:352-61.
27. West-Jordan JA, Martin PA, Abraham RJ, Edwards RH, Jackson MJ. Energy dependence of cytosolic enzyme efflux from rat skeletal muscle. *Clin Chim Acta* 1990;189:163-72.
28. Willems GM, Muijtjens AM, Lambi FH, Hermens WT. Estimation of circulatory parameters in patients with acute myocardial infarction. Significance for calculation of enzymatic infarct size. *Cardiovasc Res* 1979;13:578-87.
29. Hall JE, Guyton AC, Brands MW. Pressure-volume regulation in hypertension. *Kidney Int Suppl* 1996;55:S35-S41.
30. Schmidlin O, Sebastian AF, Morris RC, Jr. What initiates the pressor effect of salt in salt-sensitive humans? Observations in normotensive blacks. *Hypertension* 2007;49:1032-9.
31. Sullivan JM, Prewitt RL, Ratts TE, Josephs JA, Connor MJ. Hemodynamic characteristics of sodium-sensitive human subjects. *Hypertension* 1987;9:398-406.
32. Brewster LM, Taherzadeh Z, Volger S et al. Ethnic differences in resistance artery contractility of normotensive pregnant women. *Am J Physiol Heart Circ Physiol* 2010;299:H431-H436.
33. Ama PF, Simoneau JA, Boulay MR, Serresse O, Theriault G, Bouchard C. Skeletal muscle characteristics in sedentary black and Caucasian males. *J Appl Physiol* 1986;61:1758-61.
34. Brewster LM, Mairuhu G, Sturk A, van Montfrans GA. Distribution of creatine kinase in the general population: implications for statin therapy. *Am Heart J* 2007;154:655-61.
35. Pratt JH, Jones JJ, Miller JZ, Wagner MA, Fineberg NS. Racial differences in aldosterone excretion and plasma aldosterone concentrations in children. *N Engl J Med* 1989;321:1152-7.
36. Tu W, Eckert GJ, Pratt JH, Jan Danser AH. Plasma levels of prorenin and Renin in blacks and whites: their relative abundance and associations with plasma aldosterone concentration. *Am J Hypertens* 2012;25:1030-4.
37. Harshfield GA, Alpert BS, Pulliam DA, Willey ES, Somes GW, Stapelton FB. Sodium excretion and racial differences in ambulatory blood pressure patterns. *Hypertension* 1991;18:813-8.
38. Weinberger MH, Miller JZ, Luft FC, Grim CE, Fineberg NS. Definitions and characteristics of sodium sensitivity and blood pressure resistance. *Hypertension* 1986;8:II127-II134.
39. Taherzadeh Z, Brewster LM, van Montfrans GA, Vanbavel E. Function and structure of resistance vessels in black and white people. *J Clin Hypertens (Greenwich)* 2010;12:431-8.
40. Egan BM, Zhao Y, Axon RN. US trends in prevalence, awareness, treatment, and control of hypertension, 1988-2008. *JAMA* 2010;303:2043-50.

41. Martins D, Tareen N, Ogedegbe G, Pan D, Norris K. The relative risk of cardiovascular death among racial and ethnic minorities with metabolic syndrome: data from the NHANES-II mortality follow-up. *J Natl Med Assoc* 2008;100:565-71.
42. Nicholson GA, McLeod JG, Morgan G et al. Variable distributions of serum creatine kinase reference values. Relationship to exercise activity. *J Neurol Sci* 1985;71:233-45.