



## UvA-DARE (Digital Academic Repository)

### OPTIMOS-EVE design trade-off analysis

Chemla, F.; Dalton, G.; Guinouard, I.; Pragt, J.; Sawyer, E.; Spanò, P.; Tosh, I.A.; Andersen, M.I.; Navarro, R.; Hammer, F.; Kaper, L.

**DOI**

[10.1117/12.857519](https://doi.org/10.1117/12.857519)

**Publication date**

2010

**Document Version**

Final published version

**Published in**

Society of Photo-Optical Instrumentation Engineers (SPIE) Conference Series

[Link to publication](#)

**Citation for published version (APA):**

Chemla, F., Dalton, G., Guinouard, I., Pragt, J., Sawyer, E., Spanò, P., Tosh, I. A., Andersen, M. I., Navarro, R., Hammer, F., & Kaper, L. (2010). OPTIMOS-EVE design trade-off analysis. *Society of Photo-Optical Instrumentation Engineers (SPIE) Conference Series*, 7735, [77355L]. <https://doi.org/10.1117/12.857519>

**General rights**

It is not permitted to download or to forward/distribute the text or part of it without the consent of the author(s) and/or copyright holder(s), other than for strictly personal, individual use, unless the work is under an open content license (like Creative Commons).

**Disclaimer/Complaints regulations**

If you believe that digital publication of certain material infringes any of your rights or (privacy) interests, please let the Library know, stating your reasons. In case of a legitimate complaint, the Library will make the material inaccessible and/or remove it from the website. Please Ask the Library: <https://uba.uva.nl/en/contact>, or a letter to: Library of the University of Amsterdam, Secretariat, Singel 425, 1012 WP Amsterdam, The Netherlands. You will be contacted as soon as possible.

*UvA-DARE is a service provided by the library of the University of Amsterdam (<https://dare.uva.nl>)*

# PROCEEDINGS OF SPIE

[SPIDigitalLibrary.org/conference-proceedings-of-spie](https://spiedigitallibrary.org/conference-proceedings-of-spie)

## OPTIMOS-EVE design trade-off analysis

Fanny Chemla, Gavin Dalton, Isabelle Guinouard, Johannes Pragt, Eric Sawyer, et al.

Fanny Chemla, Gavin Dalton, Isabelle Guinouard, Johannes Pragt, Eric Sawyer, Paolo Spanò, Ian A. Tosh, Michael I. Andersen, Ramon Navarro, François Hammer, Lex Kaper, "OPTIMOS-EVE design trade-off analysis," Proc. SPIE 7735, Ground-based and Airborne Instrumentation for Astronomy III, 77355L (20 July 2010); doi: 10.1117/12.857519

**SPIE.**

Event: SPIE Astronomical Telescopes + Instrumentation, 2010, San Diego, California, United States

# OPTIMOS-EVE design trade-off analysis

Fanny Chemla<sup>a</sup>, Gavin Dalton<sup>b,g</sup>, Isabelle Guinouard<sup>a</sup>, Johannes Pragt<sup>c</sup>, Eric Sawyer<sup>b</sup>, Paolo Spanò<sup>d</sup>, Ian A. Tosh<sup>b</sup>, Michael I. Andersen<sup>e</sup>, Ramon Navarro<sup>c</sup>, François Hammer<sup>a</sup>, Lex Kaper<sup>f</sup>

<sup>a</sup>GEPI, Observatoire de Paris, Place Jules Janssen, F-92 195, Meudon, France;

<sup>b</sup>Rutherford Appleton Laboratory, Harwell Science & Innovation Campus, Didcot OX11 0QX, UK;

<sup>c</sup>NOVA-ASTRON, Oude Hoogeveensedijk 4, 7991 PD Dwingeloo, The Netherlands;

<sup>d</sup>INAF, Osservatorio Astronomico di Brera, Via Emilio Bianchi 46, I-23807 Merate, Italy

<sup>e</sup>Dark Cosmology Centre, Niels Bohr Institute, University of Copenhagen, Juliane Mariesvej 30, DK-2100 Kbh O, Denmark;

<sup>f</sup>Astronomical Institute Anton Pannekoek, SP 904, 1098 XH Amsterdam, The Netherlands;

<sup>g</sup>Department of Physics, University of Oxford, Keble Road, Oxford OX1 3RH UK.

## ABSTRACT

OPTIMOS-EVE (OPTical Infrared Multi Object Spectrograph - Extreme Visual Explorer) is the fiber fed multi object spectrograph proposed for the E-ELT. It is designed to provide a spectral resolution ranging from 5000 to 30.000, at wavelengths from 0.37  $\mu\text{m}$  to 1.70  $\mu\text{m}$ , combined with a high multiplex ( $>200$ ) and a large spectral coverage. The system consists of three main modules: a fiber positioning system, fibers and a spectrograph.

The OPTIMOS-EVE Phase-A study, carried out within the framework of the ESO E-ELT instrumentation studies, has been performed by an international consortium consisting of institutes from France, Netherlands, United Kingdom, Italy and Denmark.

This paper describes the design tradeoff study and the key issues determining the price and performance of the instrument.

**Keywords:** spectrograph, fibres, high multiplex, high spectral coverage, multi-objects

## 1 INTRODUCTION

The EVE study explores the possibilities to perform large FoV seeing-limited high multiplexing multi-object spectroscopy at the E-ELT using fibres. The EVE study is an independent part of the OPTIMOS study that also includes a separate study using slit mask technology. This document describes the design of the instrument, based on the technical trade-off and choices that have been made.

Chapter 2 gives a high level overview of the instrument, and all sub-systems choices are described in more details in Chapter 3. The compliance to the science requirements is reported in Chapter 4.

## 2 SHORT OVERVIEW

### 2.1 Instrument objectives

OPTIMOS-EVE will perform optical and NIR fibre based multi-object spectroscopy. OPTIMOS-EVE must present the capability of studying “small” targets (mono-objects) as well as larger objects (with IFUs). The main top level requirements are listed below:

Number of Targets	minimum of 200 seeing discs / several IFUs
Wavelength Range	370nm – 1600 nm divided in two bands (VIS 370 - 930 nm and NIR 930 – 1600 nm (goal 1700))
Total FOV	7 arcmin in diameter (goal 10 arcmin)
FOV per IFU	0.7’’ to 1.0’’ in mono-objects (MO = seeing limited targets) Few arcsec <sup>2</sup> for medium IFUs (MI) and 50 to 100 arcsec <sup>2</sup> for large IFUs (LI)
Spectral Resolution	a low resolution mode at minimum 5000 a medium resolution mode at minimum 15 000 a high resolution mode at minimum 30 000
sampling on sky	unspecified for MO (light combined in a single spectrum) maximum 0.3’’ for MI and LI

Table 1. Instrument high-level objectives

The principle of the technical roadmap of OPTIMOS-EVE is to keep the instrument simple and the concept low risk. OPTIMOS-EVE does not require AO, but could benefit from GLAO if it is operational. Indeed, we can foresee that GLAO will be relatively inefficient below 600 nm, while VIS is a required range for OPTIMOS-EVE. In any case, OPTIMOS-EVE will be designed within the scope of an uncorrected wavefront. The aim is to be able to use light gathering capabilities from first day of E-ELT, whichever the GLAO advancement status is.

In the same spirit, EVE can work usefully without ADC provided that the zenith distance is sufficiently low, even though it could also benefit from the introduction of an ADC. The ADC is perceived as an upgrade of the system that extends the capabilities of the instrument, but it is not mandatory (all scientific cases can be addressed without ADC). In case there is an ADC, it will be implemented at the E-ELT intermediate focus and designed by ESO.

### 2.2 Overall description

OPTIMOS-EVE consists in three main parts:

1) A positioner that consists in a carousel containing four focal plates. One focal plate (so-called “active”) contains the MO or IFU previously positioned and is aligned with telescope axis while the opposite focal plate is being configured.

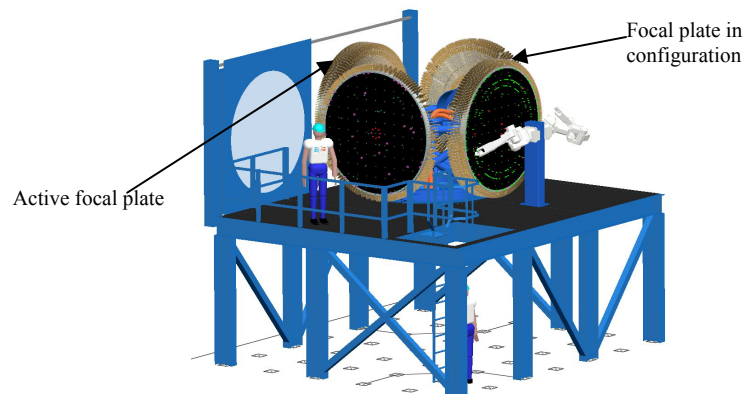

Figure 1. view of the positioner

2) microlenses and fibres that transmit light from the active focal plate to the slit of the spectrographs. Microlenses and fibres are gathered in different kind of bundles, with different apertures and different fibre sizes in order to address the 5 science cases. One kind of bundle is active at a time.

3) Two dual beam spectrographs each able to cover three spectral resolutions (low (LR), medium (MR) and high (HR)) thanks to exchangeable gratings and a slit width adaptation (done by the fibres).

The kind of targets and corresponding spectral resolutions that can be observed with EVE are:

- Mono-objects (MO) – FOV 0.9'' at low, medium and high resolution (LR, MR and HR)
- Medium IFUs (MI) – FOV 1.8\*2.9'' at low resolution (LR)
- Large IFUs (LI) – FOV 7.8\*13.5'' at low resolution (LR)

Figure 2 gives a functional overview of OPTIMOS-EVE, with some details on each function.

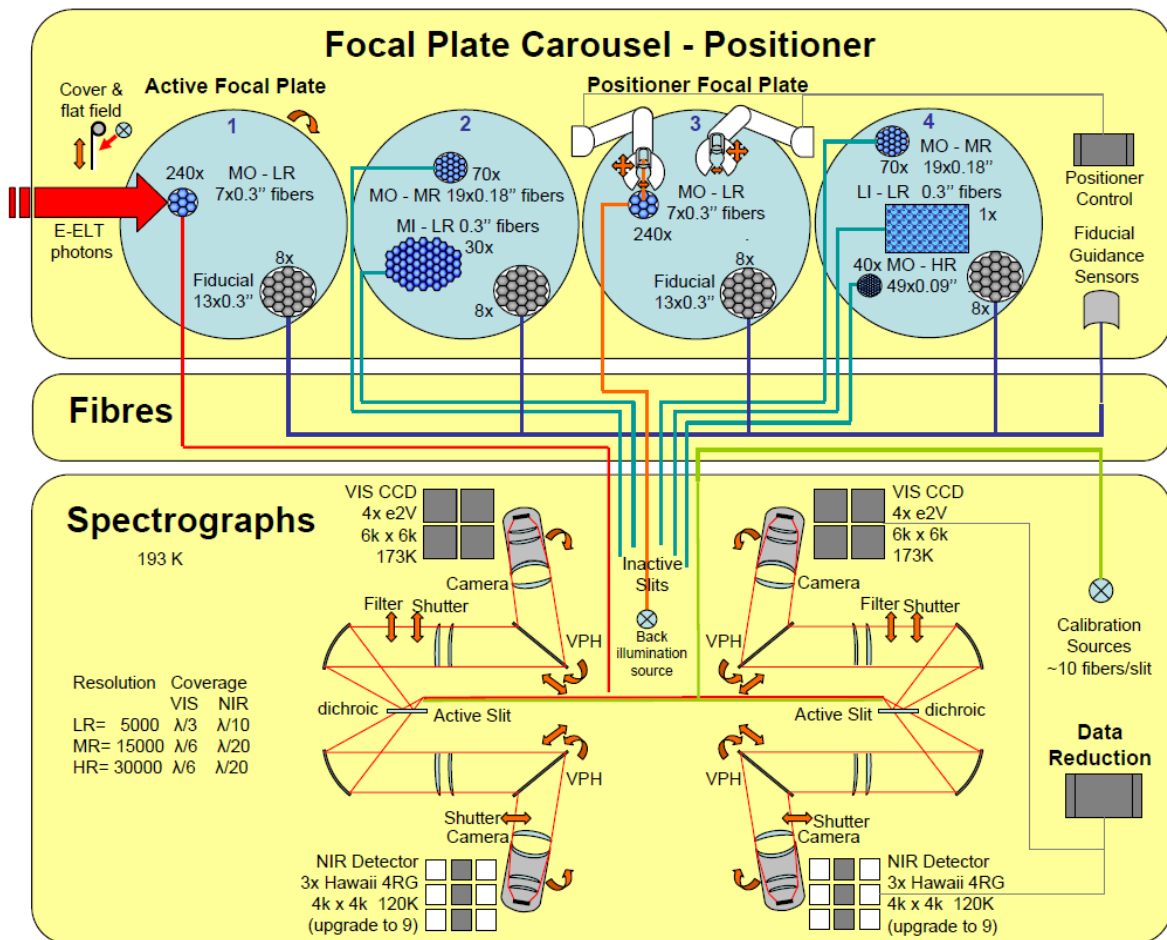

Figure 2. OPTIMOS-EVE overview

The spectrograph cameras are F/1.86.

The detectors are made with mosaics of 2\*2 6k\*6k CCD in visible (VIS) and 3\*1 4k\*4k focal plane arrays in Near-IR (NIR). For each case, 12k pixels are available for the spatial direction.

Only one resolution mode is active at a time. In the example represented on Figure 2, only the low resolution mode is active and 240 MO LR objects are observed, 120 by each dual beam spectrograph. The other slits are inactive. Focal plate 3 is configured while focal plate 1 is aligned with the telescope axis for observation.

### 3 TECHNICAL CHOICES FOR EACH SUB-SYSTEM

#### 3.1 Positioner

Two main concepts have been envisaged: pick-and place robot and echidna concept.

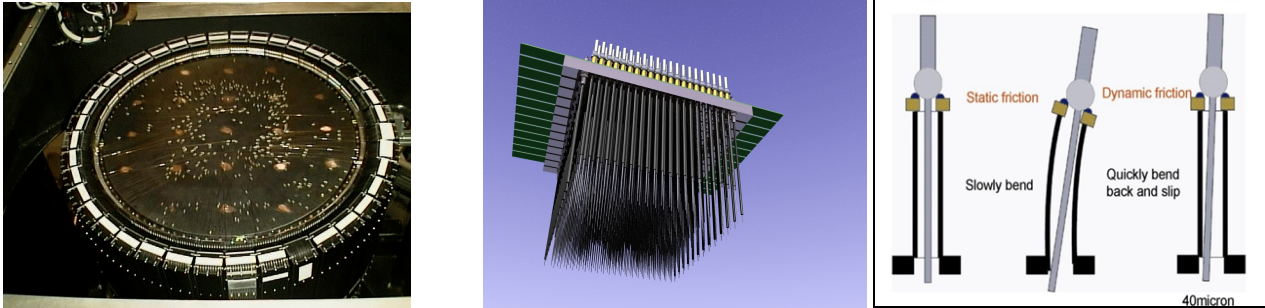

Figure 3. Pick-and-place positioner concept (left) and Echidna positioner concept (middle and right)

- Pick and place robots (FLAMES/OzPoz type see [5]): The Mono-objects or IFUs are mounted on magnetic buttons attached to the focal plate. A 2-axis robot patrols over the focal plate with a gripper that “picks” and “places” the magnetic buttons in precise locations corresponding to the expected positions of the scientific targets (Figure 3).
- Echidna positioner (FMOS type see [6]): it permits to populate a high density of fibres in a relatively small physical area: Each fibre is assembled into "spine" unit and the tilt of this determines the position of the fibre tip on the focal plane. This concept allows for very fast configuration times, but at the cost of introducing a local non-telecentricity as a function of the patrol angle for each spine.

In our case, we remind that the minimum target FOV is minimum 7 arcmin, i.e. 1.5 m, which is not well-suited to the Echidna concept. Even after several investigation of focal reducer concepts (that presented drawbacks in terms of cost, complexity and efficiency) the chosen concept is pick-and-place.

#### 3.2 Fibres and IFU units

##### 3.2.1 Fibres input

In order to limit Focal Ratio Degradation (FRD) in fibres, the F ratio in the fibres is chosen to be F/3.65. Microlenses are needed to adapt the F/17.8 E-ELT beam at the fibre entrance. The mono-object entrance aperture is 0.9'' for MO-LR and 0.81'' for MO-HR. In order not to loose light due to the geometry of injection, we have chosen to make the sampling with microlenses that re-image the telescope pupil onto the fibre core. Each microlens acts as a field lens as shown on figure below:

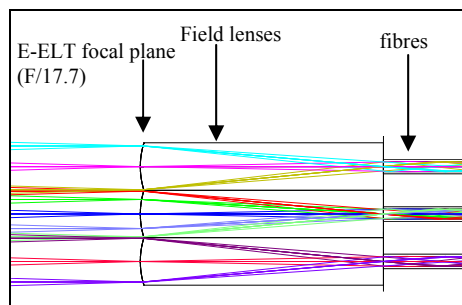

Figure 4. Fibre injection principle (pupil image on fibre core). The microlens array is actually folded (45° prism) but this is not represented here. Different colors correspond to different point of the FOV.

The principle is to sample the 0.9'' with multiple microlenses and fibres. Several possible arrangements of microlenses have been d to increase spectral resolution and spectral coverage and maintain a sufficient number of objects per spectrograph. Figure 5 illustrates the fact that smaller and more numerous microlenses are advantageous in terms of

spectral resolution (narrower slit), but will use more space on the slit in the other direction (length) and will then decrease the accessible number of objects observed at the same time.

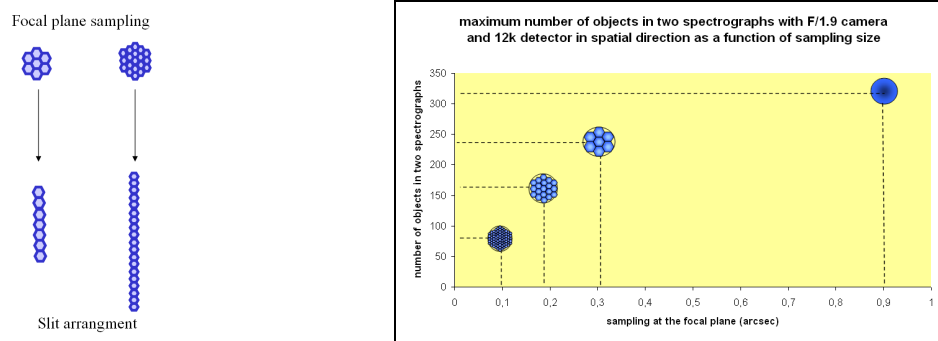

Figure 5. Illustration of the variation of slit width and length as a function of sampling choice (left) and maximum number of objects that can be accommodated in two OPTIMOS-EVE spectrographs as a function of sampling choice– valid for all spectral resolutions (right)

Knowing the physical size of the slit, we have illustrated on Figure 5 the maximum number of objects as a function of sampling choice, for camera parameters that are the ones of our design.

Since the multiplex required for MO LR is 200 minimum, the choice is rather simple: only microlens arrangement with 7 or 1 microlens are possible. For other modes (MO MR, MO HR) the requirement in multiplex is lower, and microlens arrangement containing more and smaller microlenses are possible, and likely, required.

The definitive choice can only be made by checking that the spectral coverages are sufficient for the different modes. We have represented it for LR on the following figure (Figure 6):

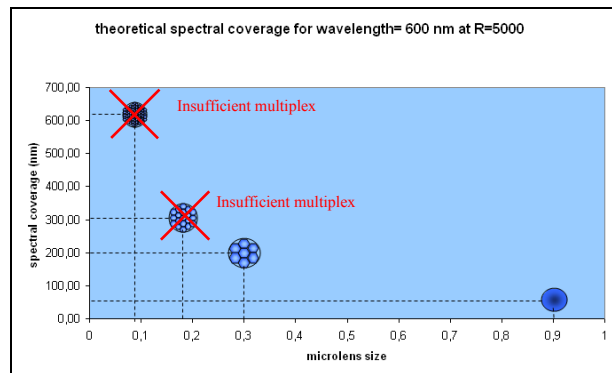

Figure 6. Theoretical spectral coverages in visible as a function of sampling choice for R=5000

For NIR, spectral coverages are not represented but are about a third of the ones represented on Figure 6 since the detector is only 4k in spectral direction (upgradable to 12k).

At R=5000, we can see that a single microlens injecting in a single fibre offers insufficient spectral coverage. Thus, the only possible microlens arrangement for MO LR objects is the following, and offer a global multiplex >200 and a spectral coverage > $\lambda/4$ .

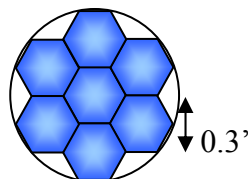

Figure 7. Microlens arrangement for mono-objects for low-resolution (R=5000)

At R=15000, multiplex is not really a limitation since it is specified that we need at least 70 MO MR, which could be reached with any of the microlens arrangements studied. Now, we also have to check the spectral coverage (Figure 8):

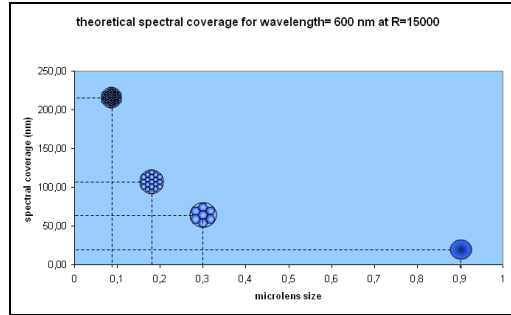

Figure 8. Theoretical spectral coverages in visible as a function of sampling choice for R=15000

A minimum of  $\lambda/8$  spectral coverage being required for MR, we can see that the microlens arrangement containing 19 fibres of 0.18'' is sufficient ( $\lambda/6$  spectral coverage is possible). This chosen for the design:

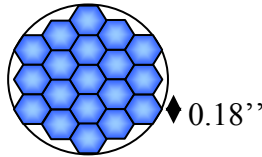

Figure 9. Microlens arrangement for mono-objects for medium-resolution (R=15 000)

At R=30 000, the theoretical spectral coverage is the following for visible:

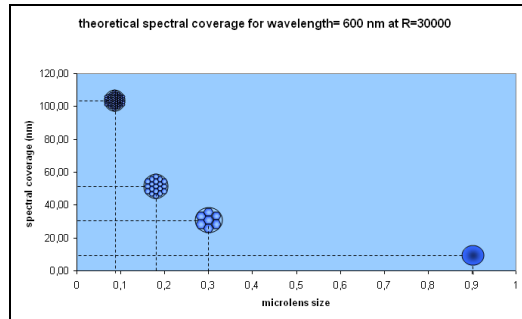

Figure 10. Theoretical spectral coverages in visible as a function of sampling choice for R=30000

The microlens arrangement using fibres of 0.09'' permits to meet the requirement on spectral coverage ( $\lambda/8$  minimum, here we can reach  $\lambda/6$ ). In addition, the fact that the microlens size is exactly twice smaller than the ones used for the MR permits to use exactly the same grating, and the same spectrograph configuration: the spectral resolution automatically doubles.

Medium and large IFU require the same spectral specifications as the low resolution mono-object. Thus, fibre size and microlens arrangement type is the same than the LR MO, i.e. hexagonal microlens arrangement with a 0.3'' microlens. The only difference is the field of view, and the following figures show the MI and LI arrangements:

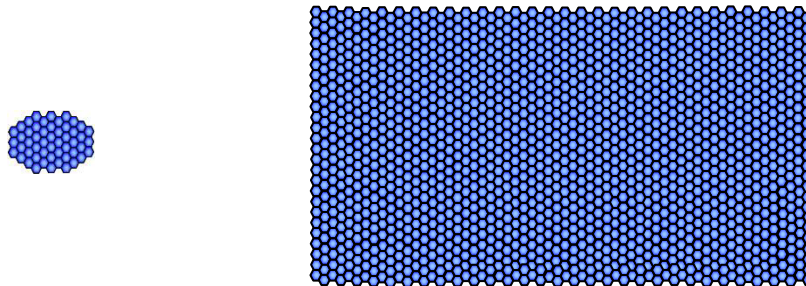

Figure 11. Microlens arrangement for MI (left) and LI (right) using 0.3'' fibres and covering respectively 1.8''x2.9'' and 7.8x13.5''



### 3.2.2 Fibres output

Now, concerning the output of the fibres, two approaches were considered:

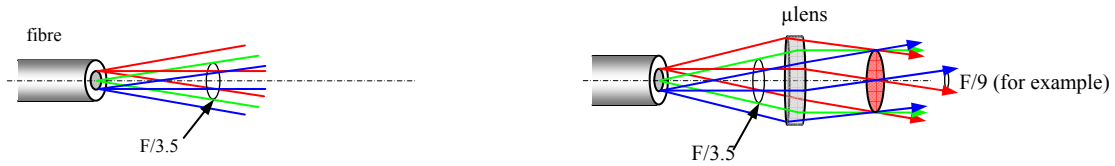

Figure 12. Fibre output possibilities: without microlens (left) or with microlens (right)

1) With no microlenses at the output, the collimator needs to collect an F/3.5 beam. The minimal distance between two fibres is limited by the fibre buffer

2) Alternatively, with microlenses at the fibres output, the constraints on the spectrograph collimator F number are relaxed. The focal length of the microlens and the fibre core diameter define the F number beam (f/9 on the figure) going towards the collimator of the spectrograph. The minimal distance between two fibres is limited by the microlens size.

Because the spectrograph design can accommodate it (entrance at F/3.5), the configuration without microlenses is chosen in order to have a sharp image of the fibre core on the detector (whereas the far field image of the microlens focal plane reimaged onto the detector produces non-sharp edges) which is helpful for limiting cross-talk (two adjacent fibres can be closer to one another). Having no microlens also permits to keep a reasonable slit length.

### 3.3 Spectrographs

#### 3.3.1 Choice of beam size

The overall size of the pupil of the spectrograph is limited by the maximum available grating size (about 300 mm). Taking a hypothesis on the maximum line density and on the working order we have evaluated that the highest resolution that we would like to reach is achievable. (for more details see [2])

#### 3.3.2 Choice of the camera F ratio

The choice of the camera F ratio directly determines the size of the image of the fibre core at the detector. One of our main concerns was to reach the multiplex capability of OPTIMOS-EVE, while keeping a reasonable number of spectrographs. Indeed, one of the main issues of instruments working at E-ELT plate scale is to solve is the problem due to the non-optimal sampling of the resolution elements by the camera because of the small pixel size.

The spatial size of the fibre image for the low resolution case on the detector is simply given by:

$$image\_size = microlens\_size \times \frac{F\_ratio\_camera}{F\_ratio\_telescope} \times FRD\_factor$$

The image size of one single fibre (in  $\mu\text{m}$ ) undispersed for LR is shown as a function the F ratio of the camera on the following figure:

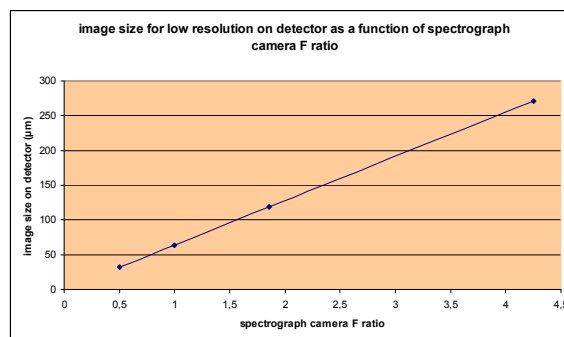

Figure 13. Image of one single fibre core size ( $\mu\text{m}$ ) on the detector as a function of camera F ratio

Dividing this curve by the pixel size (15µm), we obtain the number of “spatial” pixels (which also correspond to slit width projected onto the detector) used per spectrum:

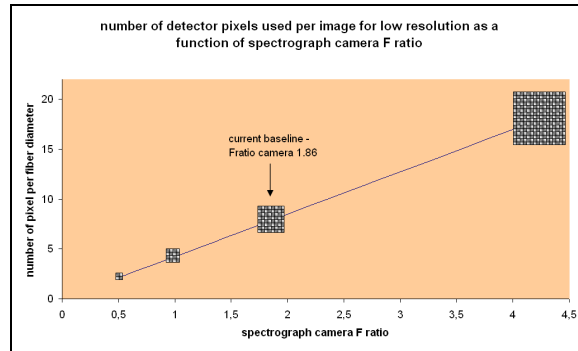

Figure 14. Number of pixels used per single 0.3” fibre core image for low resolution as a function of camera F ratio

With the  $F\_ratio\_camera$  of the current design ( $F/1.86$ ), we obtain a number of pixels of 8, which will likely be extended to 9 because of image quality. Knowing that ideally, the sampling should be done by 2 or 3 pixels, we indeed have a non-optimal sampling problem. This leads to a lower number of objects per detector than we could expect with adapted sampling. If we had a camera F ratio around 1 or slightly faster, we would use less pixels per resolution element which would allow us to increase the multiplex capability by a factor of 2 (or rather, to have only one spectrograph instead of 2).

During the study, we have realized that this inconvenience of non-optimal sampling could turn out as an advantage in the case of higher resolution, if GLAO is available. In that case, this can be very useful at the data reduction stage, for operations such as sky subtractions, especially for compact sources in the near-IR where GLAO may substantially reduce the PSF.

In the end, we have chosen to compromise between the unit cost of a spectrograph (slow F ratio permit to have a reduced cost) and the F ratio of the camera. The total number of combined visible and IR spectrograph should not exceed 2 or 3, this is why we converged towards the  $F/1.86$  camera, which is in the end relatively fast, and leads to a very large field of view and to implement more than 200 MO LR in 2 dual arm spectrographs.

Meanwhile, we can point out that for higher resolution modes, the sampling issue is less critical, and that for the highest resolution, this camera F ratio choice does lead to an optimal sampling (2 pixels) of the PSF as shown on the following graphs.

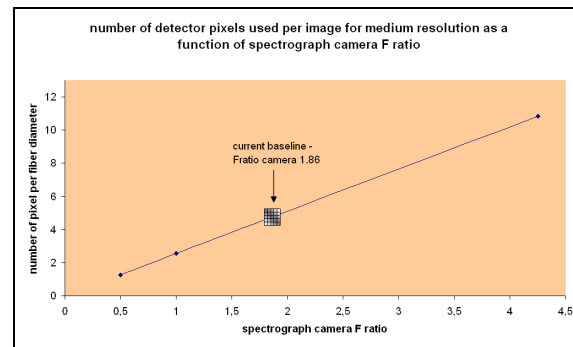

Figure 15. Number of pixels used per single fibre core image for medium resolution as a function of camera F ratio

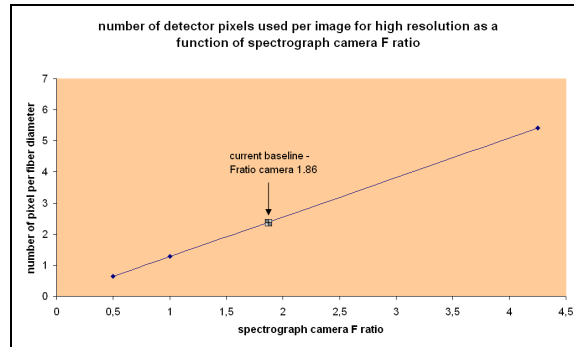

Figure 16. Number of pixels used per single fibre core image for high resolution as a function of camera F ratio

### 3.3.3 Choice of the grating type

Recent information on volume phase gratings (VPH) with Kaiser Optical System, Inc (KOSI), have shown that at the lines densities that we require at the blue end down to 370nm, are feasible and that manufacture would not be an issue.

Compared to ruled gratings, VPH present a higher efficiency and allows us to work with all-refractive design, leading to simpler systems, and so have been adopted for our design solution.

### 3.3.4 Choice of the dichroic split wavelength

The dichroic is located right after the entrance slit of the spectrograph and the cross over wavelength is set at 930 nm, right on top of an atmospheric absorption band.

Based on quantum efficiency of the detectors we could have chosen a shorter cross over wavelength (like 850 nm or so) considering that the visible CCD efficiency falls in the red (since we chose to work with a “blue optimized coating” in order to have a reasonable efficiency at the blue end of the spectrum). Meanwhile, because there are only 4k pixels in the spectral direction for the NIR and 12k in the visible, the instantaneous spectral coverage will of course be larger in the visible arm: it is better to have a visible band which is as large as possible.

### 3.3.5 Spectrograph concept

The spectrograph concept is shown in Figure 17. All optics have reasonable sizes (collimator lenses fit in a rectangle of 30x50 cm and camera lenses diameter is 37 cm maximum).

The camera is composed of 7 lenses, with glasses available in large and homogeneous size. The last lens is Fused Silica to avoid glass radiation hits onto the CCD.

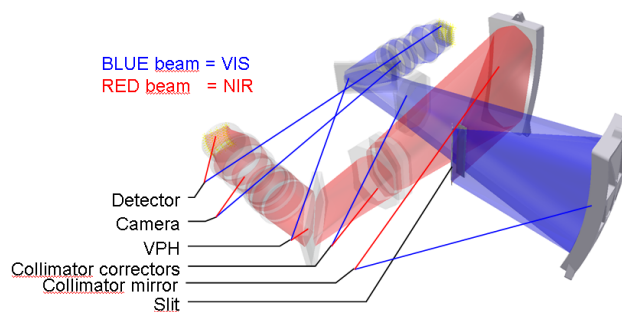

Figure 17. spectrograph concept

6 different VPH gratings are needed for visible (3x LR and 3x MR/HR) and 4 different VPH gratings for NIR (2xLR and 2xMR/HR). At LR mode, the spectral coverage is achieved by each grating without any need to rotate camera/grating. In MR/HR mode, two to three exposures per grating are needed to fully cover the spectrum.

### 3.3.6 Spectrograph thermal environment

There are special 3 temperature levels within the spectrographs as described below and shown in figure 18.

- 1) The two spectrographs with 2 arms each (VIS and NIR) are located inside an isolated, ambient pressure cold chamber, cooled by a commercial chiller. This provides a stable environment at a temperature of 193K. All parts of the spectrographs, including last meters of the fibres and the slitwheel, are located inside this cold chamber.
- 2) The Visual arm of both spectrographs is equipped with a mosaic of detectors at the focal plane, measuring 180x180 mm. These detectors are located inside vacuum cryostats and are operated at a temperature of 173K. Cooling is done with continuous flow liquid nitrogen cryostats, similar to actual systems on the VLT.
- 3) Both the camera and detector focal plane of the Near Infrared arm of both spectrographs will be located inside vacuum cryostats and operated at a temperature of 120K. Two continuous flow liquid nitrogen cryostats are foreseen for the camera-detector assembly. The cryostats are similar to the visual cryostats described above.

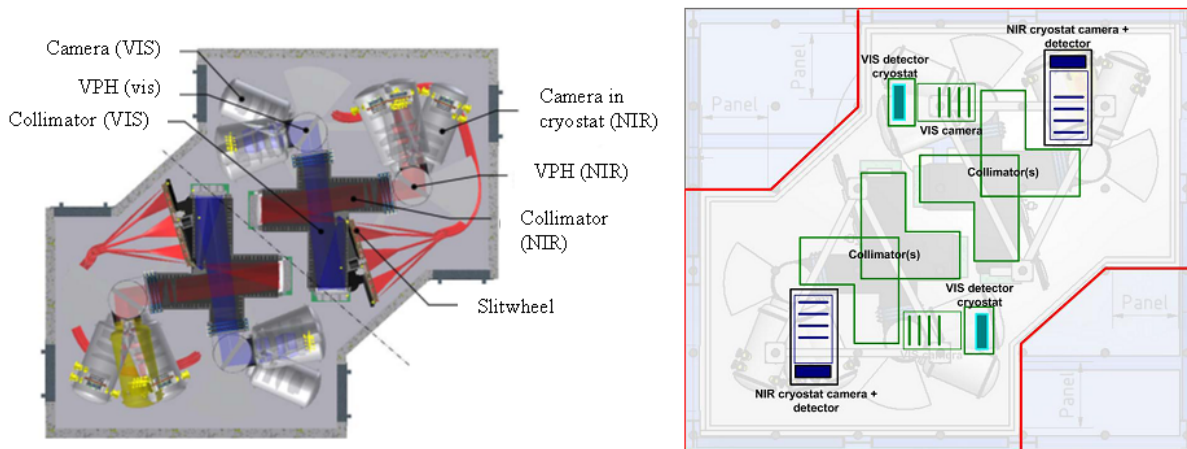

Figure 18. Spectrograph mechanical overview (left) and temperature regimes (right): The area inside the red enclosure is at 193 K, the VIS detectors are at 173 K and blue parts (camera and NIR detector) are cooled down to 120 K

The different temperature regimes within the spectrograph are defined to reach a sky thermal background limited instrument. Figure 19 shows a graphical representation of the results of simulations. We note that both the telescope contribution and contribution of the fibres are smaller than the sky background in the wavelength range  $< 1.7 \mu\text{m}$ . Close to the  $1.7 \mu\text{m}$ , it starts to get close to the sky background limit. The thermal background from the instrument stays well below the sky background level.

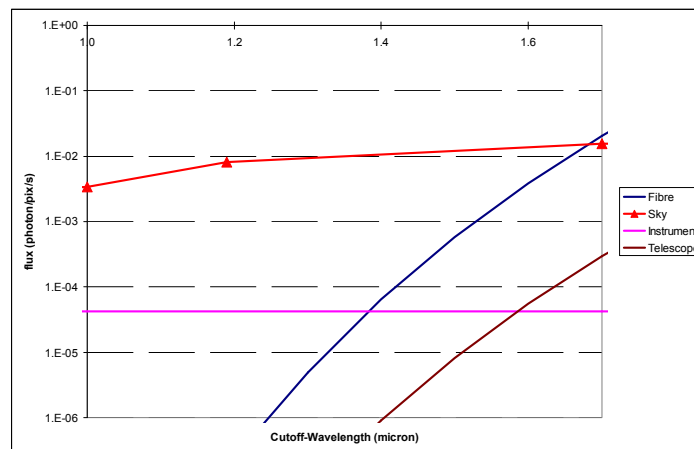

Figure 19. Thermal backgrounds graphic comparison as a function of cut-off wavelength

## 4 COMPLIANCE MATRIX

Requirement	Requirement value	Current design value	Compliant?
Wavelength range	370 nm – 1600 nm	365 nm - 1700 nm	YES
Field of view	7' minimum 10' goal	10'	YES
Aperture for MO	0.9''	0.9''	YES
Pixel sampling	At least 2 pixels	Minimum 8 pixels	YES
Target acquisition accuracy	10% of current aperture (0.09'' = 324 μm)	306 μm TBC	YES
Throughput	20% for primary mode Goal 25%	MO-LR 26.2% MO-MR 21.8% MI 18.8% MO-HR 11.1%	YES
Instrument thermal background	Sensitivity not limited by thermal background	OK (cooling of optics and detectors)	YES
Scattered light and ghost images	Stray light: 10% maximum Ghost in focus on detector: maximum level 1/104 of primary image	OK	YES
6. IFU type (size L''XW'')	MO LR and MR 0.9'' ± 0.2'' MO HR 0.72'' MI 1.8''x3'' ± 0.3'' LI 9''x15''	M0 LR and MR 0.9'' MO HR 0.81'' MI 1.8''x2.9'' LI 7.8''x13.5''	YES for MO Very close for MI and LI (negligible impact on science)
1. Resolutions VIS and NIR	LR 5000 MR 15 000 HR 30 000	LR 6000 MR 18 000 HR 30 000	YES
2. Simultaneous Spectral range VIS	λ/4 for LR λ/8 for MR and HR	λ/3 for LR λ/6 for MR and HR	YES
2. Simultaneous Spectral range NIR	λ/12 for LR λ/24 for MR and HR	λ/10 for LR λ/20 for MR and HR	YES
7 Multiplex (N, for each type of IFU)	200 MO LR / 70 MO MR / 30 MO HR 30 MI 1 LI	240 MO / 70 MO MR /40 MO HR 30 MI 1 LI	YES

Table 2. Compliance matrix

## CONCLUSION

Despite a very challenging set of specifications, requiring both a high number of targets observed at the same time and a large spectral coverage, the instrument concept of OPTIMOS-EVE remains simple without any need to use difficult or non-robust technologies.

The link between the focal plate and the spectrograph being done by fibres (which are known, thanks to the GIRAFFE experience, to be robust and low risk), the instrument is very versatile: fibre exchange is a very simple operation and permits to adapt easily the fibre width and the science object length on the slit.

The design is fully compliant with the science specification, using common technologies. This makes OPTIMOS-EVE a very promising and efficient instrument.

## REFERENCES

- [1] Navarro.R, et al, "Project overview of OPTIMOS-EVE: the fibre-fed multi-object spectrograph for the E-ELT" Proc. SPIE 7735-91, (2010)
- [2] Spanò, P., Tosh, I., Chemla, F., "OPTIMOS-EVE optical design of a very efficient, high-multiplex, large spectral coverage, fibre-fed spectrograph at EELT," Proc. SPIE 7735-248, (2010)
- [3] Guinouard, I., Chemla, F., Huet, J., Hammer, J., Flores, H., "Development of five multifibre links for the OPTIMOS-EVE study for the E-ELT," Proc. SPIE 7739-188, (2010)
- [4] Dalton, G., B., Whalley, M., Sawyer, E., Tosh, I., Terrett, D., "Fibre positioning revisited: the use of an off-the-shelf assembly robot for OPTIMOS-EVE," Proc. SPIE 7739-192, (2010)
- [5] PASQUINI Luca et al, "FLAMES : a multiobject fibre facility for the VLT".
- [6] AKIYAMA Masayuki et al, "Performance of Echidna fiber positioner for FMOS on Subaru".