



UvA-DARE (Digital Academic Repository)

Quantification of the fraction poorly deformable red blood cells using ektacytometry

Streekstra, G.J.; Dobbe, J.G.G.; Hoekstra, A.G.

DOI

[10.1364/OE.18.014173](https://doi.org/10.1364/OE.18.014173)

Publication date

2010

Document Version

Final published version

Published in

Optics Express

[Link to publication](#)

Citation for published version (APA):

Streekstra, G. J., Dobbe, J. G. G., & Hoekstra, A. G. (2010). Quantification of the fraction poorly deformable red blood cells using ektacytometry. *Optics Express*, *18*(13), 14173-14182. <https://doi.org/10.1364/OE.18.014173>

General rights

It is not permitted to download or to forward/distribute the text or part of it without the consent of the author(s) and/or copyright holder(s), other than for strictly personal, individual use, unless the work is under an open content license (like Creative Commons).

Disclaimer/Complaints regulations

If you believe that digital publication of certain material infringes any of your rights or (privacy) interests, please let the Library know, stating your reasons. In case of a legitimate complaint, the Library will make the material inaccessible and/or remove it from the website. Please Ask the Library: <https://uba.uva.nl/en/contact>, or a letter to: Library of the University of Amsterdam, Secretariat, Singel 425, 1012 WP Amsterdam, The Netherlands. You will be contacted as soon as possible.

UvA-DARE is a service provided by the library of the University of Amsterdam (<https://dare.uva.nl>)

Quantification of the fraction poorly deformable red blood cells using ektacytometry

G. J. Streekstra^{1*}, J. G. G. Dobbe¹, and A. G. Hoekstra²

¹Dept. of Biomedical Engineering and Physics, Academic Medical Center, University of Amsterdam, Meibergdreef 9, 1105 AZ Amsterdam, The Netherlands

²Computational Science, Faculty of Science, University of Amsterdam, Science Park 107, 1098 XG Amsterdam, The Netherlands.

*g.j.streekstra@amc.uva.nl

Abstract: We describe a method to obtain the fraction of poorly deformable red blood cells in a blood sample from the intensity pattern in an ektacytometer. In an ektacytometer red blood cells are transformed into ellipsoids by a shear flow between two transparent cylinders. The intensity pattern, due to a laser beam that is sent through the suspension, is projected on a screen. When measuring a healthy red blood cell population iso-intensity curves are ellipses with an axial ratio equal to that of the average red blood cell. In contrast poorly deformable cells result in circular iso-intensity curves. In this study we show that for mixtures of deformable and poorly deformable red blood cells, iso-intensity curves in the composite intensity pattern are neither elliptical nor circular but obtain cross-like shapes. We propose a method to obtain the fraction of poorly deformable red blood cells from those intensity patterns. Experiments with mixtures of poorly deformable and deformable red blood cells validate the method and demonstrate its accuracy. In a clinical setting our approach is potentially of great value for the detection of the fraction of sickle cells in blood samples of patients with sickle cell disease or to find a measure for the parasitemia in patients infected with malaria.

©2010 Optical Society of America

OCIS codes: (170.15.30) Cell analysis; (290.5850) Scattering, particles

References and links

1. M. Bessis, and N. Mohandas, "Laser Diffraction Patterns of Sickle Cells in Fluid Shear Fields," *Blood Cells* **3**, 229–239 (1977).
2. J. G. G. Dobbe, M. R. Hardeman, G. J. Streekstra, J. Strackee, C. Ince, and C. A. Grimbergen, "Analyzing red blood cell-deformability distributions," *Blood Cells Mol. Dis.* **28**(3), 373–384 (2002).
3. Y. C. Fung, *Biomechanics*, (Springer Verlag, New York, 1984).
4. R. M. Johnson, C. J. Féo, M. Nossal, and I. Dobo, "Evaluation of covalent antisickling compounds by PO₂ scan ektacytometry," *Blood* **66**(2), 432–438 (1985).
5. S. Chien, J. Dormandy, E. Ernst, and A. Matrai, *Clinical Hemorheology* (Martinus Nijhoff publishers, Boston, 1987), p. 238.
6. T. Fischer, and H. Schmidt Schönbein, "Tank Tread Motion of red cell membranes in viscometric flow: behavior of intracellular and extracellular markers (with Film)," *Blood Cells* **3**, 351–365 (1977).
7. M. Bessis, and N. Mohandas, "A Diffractometric Method for the Measurement of Cellular Deformability," *Blood Cells* **1**, 307–313 (1975).
8. M. R. Hardeman, P. T. Goedhart, J. G. G. Dobbe, and K. P. Lettinga, "Laser-assisted Optical Rotational Analyser (LORCA); A new instrument for measurement of various structural hemorheological parameters," *Clin. Hemorheol.* **14**(4), 605–619 (1994).
9. J. G. G. Dobbe, G. J. Streekstra, M. R. Hardeman, C. Ince, and C. A. Grimbergen, "Measurement of the distribution of red blood cell deformability using an automated rheoscope," *Cytometry* **50**(6), 313–325 (2002).

10. G. J. Streekstra, A. G. Hoekstra, and R. M. Heethaar, "Anomalous diffraction by arbitrarily oriented ellipsoids: applications in ektacytometry," *Appl. Opt.* **33**(31), 7288–7296 (1994).
 11. C. Allard, N. Mohandas, and M. Bessis, "Red Cell Deformability Changes in Hemolytic Anemias Estimated by Diffractometric Methods (Ektacytometry)," *Blood Cells* **3**, 209–221 (1977).
 12. M. Bessis, N. Mohandas, and C. Feo, "Automated ektacytometry: a new method of measuring red cell deformability and red cell indices," *Blood Cells* **6**(3), 315–327 (1980).
 13. J. Plasek, and T. Marik, "Determination of undeformable erythrocytes in blood samples using laser light scattering," *Appl. Opt.* **21**(23), 4335–4338 (1982).
 14. M. Bessis, C. Feo, and E. Jones, "Quantitation of red cell deformability during progressive deoxygenation and oxygenation in sickling disorders (the use of an automated Ektacytometer)," *Blood Cells* **8**(1), 17–28 (1982).
 15. D. J. Abraham, A. S. Mehanna, F. C. Wireko, J. Whitney, R. P. Thomas, and E. P. Orringer, "Vanillin, a potential agent for the treatment of sickle cell anemia," *Blood* **77**(6), 1334–1341 (1991).
 16. L. Lawson, and J. Hanson, *Solving Least Squares Problems*, (Prentice-Hall, Englewood Cliffs, N.J., 1974), pp. 18.
 17. S. Twomey, *Introduction to the mathematics of inversion in remote sensing and indirect measurements*, (Elsevier Scientific Publishing Company, Amsterdam, 1977), pp. 115.
 18. W. H. Press, B. P. Flannery, S. A. Teukolsky, and W. T. Vetterling, *Numerical Recipes in C*, (Cambridge University Press, Cambridge, 1988), pp. 528.
 19. G. J. Streekstra, A. G. Hoekstra, E. J. Nijhof, and R. M. Heethaar, "Light scattering by red blood cells in ektacytometry: Fraunhofer versus anomalous diffraction," *Appl. Opt.* **32**, 2266–2272 (1993).
 20. H. C. van de Hulst, *Light Scattering by Small Particles*, (Wiley, New York, 1957), pp. 3.
 21. M. R. Hardeman, R. M. Bauersachs, and H. J. Meiselman, "RBC Laser diffractometry and RBC Aggregometry with a rotational viscometer: comparison with rheoscope and Myrenne Aggregometer," *Clin. Hemorheol.* **8**, 581–593 (1988).
-

1. Introduction

In some hemolytic anemias, like hereditary spherocytosis, malaria and sickle cell disease, a fraction of red blood cells is less deformable due to stiffening of the cell membrane [1,2]. The reduced deformability of red blood cells as present in such diseases affects both the macro and the microcirculation. In the macro circulation, blood flow is affected by drastically increased whole blood viscosity which even exceeds the viscosity of a suspension of rigid spheres with comparable volume fraction [3]. In the microcirculation the rigidity of the sickle cells are found to cause vaso-occlusive blockades [4,5].

The deformability of red blood cells can be measured from their shape when subject to a shear flow in a medium with relatively high viscosity. In such a flow red blood cells are elongated by shear forces and transform into ellipsoids [6]. The eccentricity of the ellipsoidal cells is a measure of red cell deformation. The red cell deformation can either be estimated by a rheoscope (using a microscope which allows detection of the shapes of individual red blood cells) or by ektacytometry which is based on analysis of laser light scattered by a population of red blood cells in a suspension [7,8].

With a rheoscope it is possible to analyze individual RBCs and generate the deformability distribution within a cell population. It has been shown that a broad, in some cases bi-modal, distribution of red cell deformability actually exist in the aforementioned diseases [9]. Although the rheoscope can estimate detailed red cell deformability distributions, the method is complicated and rather time consuming and therefore not suitable for routine measurement of red cell deformability.

From the beginning of its existence, ektacytometry has been used to measure the deformability of cells from patients with hemolytic anemias like sickle cell disease [7,11]. An ektacytometer allows fast measurement of red blood-cell deformability. However, currently it only provides the average red blood-cell deformability of a population [10]. In an ektacytometer a diluted suspension of red blood cells is subject to a shear flow between two coaxial transparent cylinders. Laser light is sent through the sheared suspension and scattered

by the ellipsoidal red blood cells. The resulting intensity pattern is projected on a screen. In a normal red cell population points of equal intensity in the intensity pattern build up elliptical curves: the iso-intensity curves. The eccentricity of the iso-intensity curves is equal to eccentricity of the average ellipsoid within the red cell population [10]. An iso-intensity curve yields a long axis l and a short axis s of the ellipse. In routine measurements, a deformation index DI , defined by $(l-s)/(l+s)$, is measured at different angular velocities of the outer cylinder. DI is plotted against the calculated shear stress in the suspension and represents the deformability of the red cells under consideration. It varies between 0 for low shear stresses to as much as a maximum value of approximately 0.6 at high shear stress (30 Pa).

In blood samples of patients with sickle cell disease or in blood samples infected with *Plasmodium Falciparum*, the red cell population consists of a mixture of deformable cells and poorly deformable cells [9]. The deformable subpopulation behaves like normal red blood cells and in the ektacytometer they transform into ellipsoids yielding the corresponding elliptical iso-intensity curves. The poorly deformable cells in such a blood sample exhibit a rigid body rotation in a shear flow resulting in nearly circular iso-intensity curves in the ektacytometer [12]. The intensity pattern in ektacytometry is therefore a composition of patterns representing highly-deformable and poorly deformable cells. In this composite intensity pattern the iso-intensity curves are not elliptical but obtain cross-like shapes [1].

In literature on ektacytometry only few attempts were made to quantify the amount of poorly deformable red blood cells from a composite intensity pattern as described above. In studies of Allard et al. [11] and Bessis and Mohandas [1], the quantification was performed by analyzing photographic images of the intensity pattern. Although quantitative information can be obtained by this method, only a rough estimation of the fraction of poorly deformable cells was possible. Furthermore, the analysis of the photographs turned out to be time consuming and difficult to standardize [12]. In a study of Plasek and Marik the latter problem was recognized [13]. They tested a method to obtain the fraction of poorly deformable cells from the intensity at one single position in the intensity pattern. The intensity was measured with a photoresistor at two different shear rates. The two resulting signals were combined to obtain an index I_u which is related to the actual fraction of poorly deformable cells. In their derivation of I_u it is shown that it must be proportional to the fraction of poorly deformable cells. However, in the associated experiments on mixtures of deformable and glutaraldehyde-fixed poorly deformable red blood cells, this was not confirmed.

At a later stage, ektacytometry was used for the study of the effect of antisickling agents on the deformability of sickle cells [4,14,15]. In these studies the authors fall back on the deformation index DI that is designed for populations with relatively narrow distributions of the deformability of the red blood cells. Although DI will decrease with an increase in the amount of poorly deformable cells in the population, no quantitative information about the fraction of poorly deformable cells is obtained by DI .

In conclusion, no reliable method to obtain the fraction poorly deformable red blood cells from the intensity pattern in ektacytometry is available to date. Therefore, we developed a method based on existing least squares problem solving techniques [16–18]. In our method the complete intensity pattern is used in the estimation of the fraction poorly deformable cells.

In order to gain insight into the characteristics of the composite intensity pattern, we first calculated the iso-intensity curves of a mixture of prolate and oblate spheroids. These spheroids represent the deformable and poorly deformable red blood cells as observed in an ektacytometer. For the calculation of the iso-intensity curves we used the anomalous diffraction approximation for ellipsoidal particles [19], which is valid for particles with a relative refractive index and size of a red blood cell.

In order to investigate the accuracy of our method, it was tested in experiments with known mixtures of deformable and poorly deformable glutaraldehyde-fixed red blood cells.

2. Isointensity curves of a mixture of oblate and prolate spheroids

To gain insight into the characteristics of the intensity pattern produced by a mixture of deformable and poorly deformable red blood cells, we calculated the isointensity curves of a mixture of oblate and prolate spheroids. For this purpose the anomalous diffraction approximation for ellipsoids was used [19]. In the anomalous diffraction theory both the light that is traveling along and the light traversing the particle is taken into account in the calculation of the scattered intensity. Consider a single ellipsoidal particle with semi axes $a > b > c$, situated in the origin of a Cartesian coordinate system and a , b and c oriented along the x , y and z axes respectively (Fig. 1). The particle is illuminated by a plane wave traveling in the z -direction. In the anomalous diffraction approximation the intensity I_A at a point (x, y, z) far from the particle is given by [14]:

$$I_A = I_o (I / k^2 r^2) |S(\nu)|^2, \quad (1)$$

with

$$S(\nu) = \alpha^2 \int_0^{\pi/2} [1 - \exp(-i\phi_{\max} \sin \tau)] J_o(\alpha \nu \cos \tau) \sin \tau \cos \tau d\tau,$$

$$\alpha = k\sqrt{ab}, \quad \phi_{\max} = 2kc(m-1), \quad q = a/b,$$

$$\nu = \frac{1}{r} [(x^2/q) + qy^2]^{1/2}, \quad r = (x^2 + y^2 + z^2)^{1/2}.$$

In Eq. (1), I_o denotes the intensity of the incident wave, $J_o(u)$ is the zeroth-order Bessel function of u , k is the magnitude of the wave vector of the light in the medium surrounding the particle, q is the axial ratio a/b of the ellipsoid and α is the size parameter for an ellipsoidal particle.

Equation (1) shows that all points in space with a fixed value of ν build up curves of equal intensity. On a screen perpendicular to the direction of the incident light these isointensity curves are ellipses. In a red cell suspension with *uniform* deformation of all the cells within the population, the isointensity curves in the intensity pattern are elliptical with an axial ratio q_p equal to the axial ratio q of the cells. Furthermore, the axial ratios of the isointensity curves are independent of the intensity level of these curves. If the cell population consists of a mixture of deformable and poorly deformable cells, the relation between cell shape and intensity pattern is more complicated. To calculate the intensity patterns of such mixtures, we used the fact that in a diluted cell suspension as present in the ektacytometer, the intensity at any point on the screen is the sum of the intensities due to the light scattered by the individual cells [20].

Figure 2 represents the theoretical isointensity curves of a suspension with equal amounts of prolate ($q = 4.7$) and oblate spheroids ($q = 1$) representing the deformable and poorly deformable red blood cells. The isointensity curves 1, 2 and 3 in Fig. 2 indicate intensity levels $I(0)/2$, $I(0)/4$ and $I(0)/10$.

Although in general the isointensity curves in the pattern will not be elliptical, it is still possible to obtain an axial ratio q_p from the pattern. However, the value of q_p depends on

the intensity level of the isointensity curves. The corresponding values of q_p are 1.9, 2.2 and 2.4.

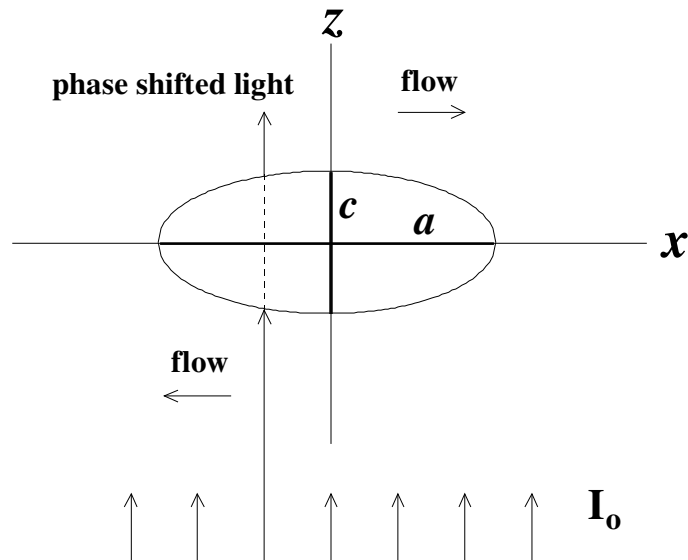

Fig. 1. Ellipsoidal particle with semi-axes a , b and c illuminated by a laser beam. The b -axis is in the y -direction perpendicular to the x - z plane.

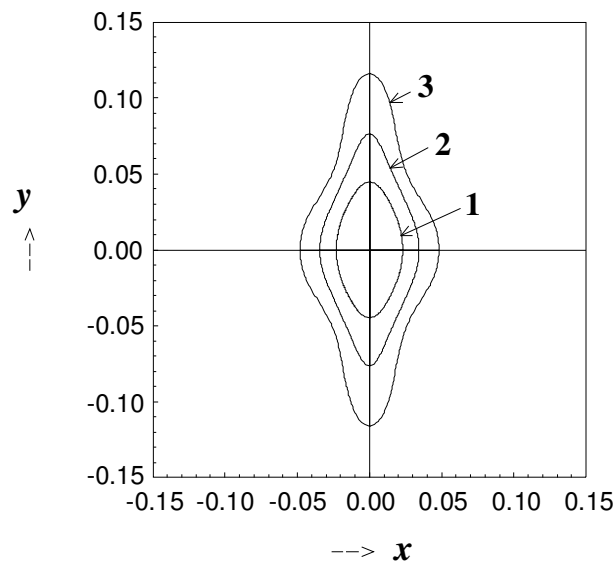

Fig. 2. Isointensity curves of a 1:1 mixture of oblate ($q = 1$, $\alpha = 56.9$) and prolate ($q = 4.7$, $\alpha = 48.5$) spheroids. The volumes of the particles are 95 fl . The isointensity curves 1, 2 and 3 represent intensities $I(0)/2$, $I(0)/4$, and $I(0)/10$ respectively ($I(0)$ is the intensity at the center of the screen).

3. Determination of the fraction poorly deformable cells

In the ektacytometer, the intensity at any point on the screen is the sum of the intensities due to the light scattered by the individual cells. If the cell population consists of two subpopulations with relatively narrow distributions of the axial ratio, we can assign single values q_1 and q_2 to these subpopulations [10]. In this case the intensity of the scattered light on the screen can be approximated by

$$I_{sc}(x, y) = n_1 I(x, y, q_1) + n_2 I(x, y, q_2). \quad (2)$$

where $I(x, y, q_1)$ and $I(x, y, q_2)$ represent the intensities of the light scattered by cells with axial ratios q_1 and q_2 . In Eq. (2), n_1 and n_2 are the numbers of cells with axial ratios q_1 and q_2 , respectively.

In our measuring system [19,21], I_{sc} is measured at many points (x, y) on a screen. Measurement of the intensity at m different positions on the screen results in m equations like Eq. (2). These equations can be written as one matrix equation

$$I_{meas} = \mathbf{I}_{mat} \bullet \mathbf{n}. \quad (3)$$

In this matrix equation, \mathbf{I}_{meas} is a vector of length m containing the measured intensities $I_{sc}(x, y)$ of the composite intensity pattern, \mathbf{I}_{mat} is a $(m \times 2)$ matrix and \mathbf{n} is a vector with two elements n_1 and n_2 which are the numbers of cells as in Eq. (2). The rows of \mathbf{I}_{mat} represent the intensities at the m positions on the screen for the single cells with axial ratios q_1 and q_2 . In this way \mathbf{I}_{mat} is the matrix that contains the intensity patterns of the two elementary particles building up the composite intensity patterns.

Since we are interested in the numbers of cells (n_1, n_2) with axial ratios q_1 and q_2 that go with a certain measurement vector \mathbf{I}_{meas} we must invert Eq. (3) to obtain n_1 and n_2 . This inverse relation is given by

$$\mathbf{n} = \mathbf{I}_{mat}^{-1} \bullet \mathbf{I}_{meas}. \quad (4)$$

where \mathbf{I}_{mat}^{-1} is the $(2 \times m)$ pseudoinverse of \mathbf{I}_{mat} . For the inversion of \mathbf{I}_{mat} we use Singular Value Decomposition [16,18].

If n_1 and n_2 represent the numbers of poorly deformable and deformable red blood cells in the population, respectively, the fraction of poorly deformable cells n_u is calculated by

$$n_u = n_1 / (n_1 + n_2). \quad (5)$$

Equation (4) produces a solution vector \mathbf{n} that is the best approximation in the least-squares sense [16].

4. Experiments

To investigate the usefulness of the method that is described in the former paragraph, we analyzed the intensity patterns of mixtures of deformable and poorly deformable cells. The poorly deformable cells were prepared by fixation for 30 minutes in a 0.5% glutaraldehyde solution. Five different mixtures of deformable and poorly deformable cells were prepared in which the fractions of poorly deformable cells were varied between 0 and 100%. In all mixtures, the red cell concentrations were adjusted to $5.0 \cdot 10^4$ cells/ μl .

During the measurements of the intensity patterns in the ektacytometer, the shear stress in the cell suspension was approximately 60 Pa. At this shear stress the deformable cells have reached a degree of deformation which is close to their maximal deformation and the fixed

cells exhibit rigid body rotation. In order to account for fluctuations of local cell concentration during the measurement, 10 images were scanned for every mixture.

Figure 3 (top row) shows the isointensity curves in an intensity pattern of 100% (left) and 0% (right) poorly deformable red blood cells. The isointensity curves of the suspension with only deformable cells are elliptical with axial ratio q of approximately 3. The isointensity curves corresponding to the poorly deformable cells are circular ($q \gg 1$). The composite intensity patterns due to mixtures of deformable and poorly deformable cells are shown in Fig. 3 (bottom row) and Fig. 4. In all mixtures the shape of the isointensity curves depends on the intensity level of the curves. This corresponds to the calculations that we performed on mixtures of prolate and oblate ellipsoids.

If we compare Fig. 2 with the measured isointensity curves of the sample with a 1:1 mixture of deformable and poorly deformable cells (Fig. 4) we observe the same characteristics: at high intensity levels the isointensity curves tend to be elliptical whereas at lower intensity levels the influence of the circular part of the pattern becomes more manifest.

For the estimation of the fraction of poorly deformable cells, a matrix \mathbf{I}_{mat} and a vector \mathbf{I}_{meas} had to be obtained from the measurements. For the two columns of \mathbf{I}_{mat} , the measured intensity patterns of the poorly deformable ($q_1 \gg 1$) and the deformable ($q_2 \gg 3.0$) cells were used. To minimize the errors produced by fluctuations in the local red cell concentrations during the measurements, the mean of 10 images were used for each element of \mathbf{I}_{mat} . Both columns contained $m = 45 \times 45$ elements obtained from the relevant part of the intensity pattern. The intensities of the composite intensity patterns were obtained from the same part of the intensity pattern and collected in the vector \mathbf{I}_{meas} .

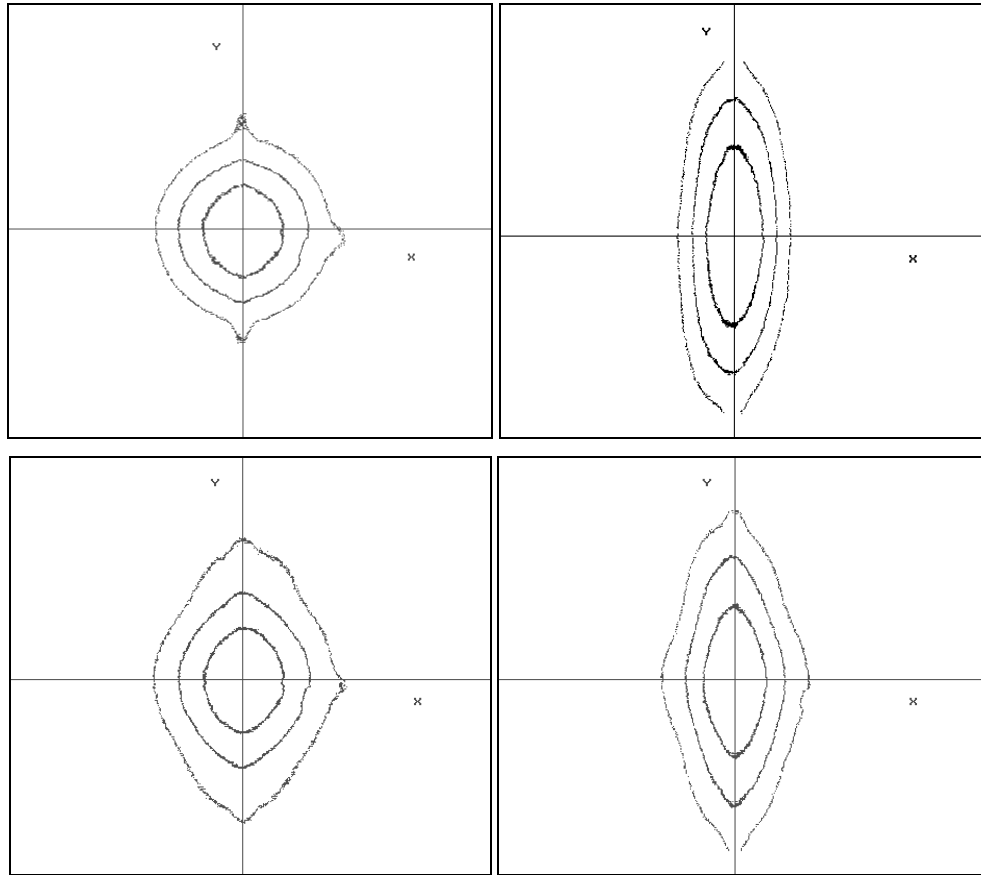

Fig. 3. Isointensity curves in the intensity patterns of suspensions with different fractions n_u of poorly deformable cells (top row: left $n_u = 1.0$, right $n_u = 0.0$; bottom row: left $n_u = 0.75$, right $n_u = 0.25$).

Equations (4) and (5) were used for the estimation of n_1 and n_2 and the fraction of poorly deformable cells n_u . Figure 5 shows the value of $n_u(\text{measured})$ obtained from the composite intensity patterns for five prepared mixtures of poorly deformable and deformable red blood cells: $n_u(\text{sample}) = 0.0, 0.25, 0.5, 0.75$ and 1.00 respectively. For every mixture, 10 images were scanned and the corresponding values of n_u were estimated from each image.

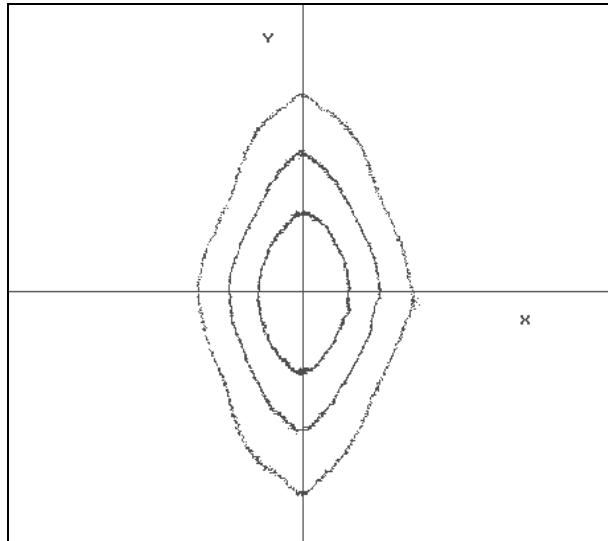

Fig. 4. Isointensity curves in the intensity pattern of a 1:1 mixture ($n_u = 0.50$) of poorly deformable ($q \gg 1$) and deformable ($q \gg 3$) red blood cells.

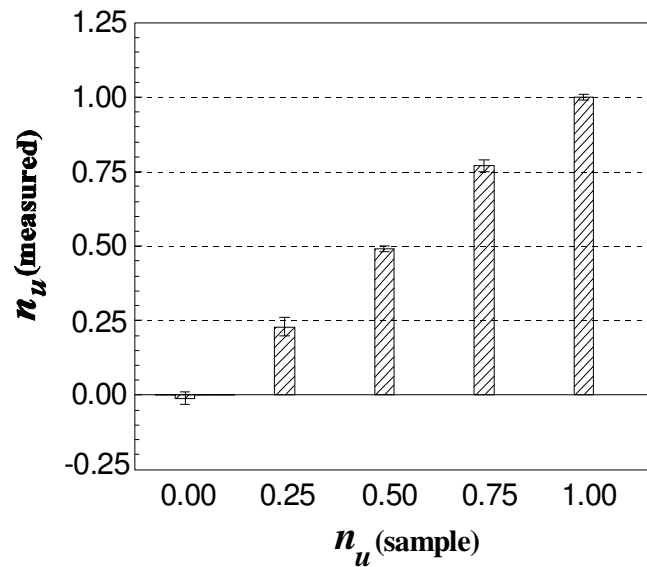

Fig. 5. The measured fractions of poorly deformable red blood cells $n_u(\text{measured})$ versus the fractions of poorly deformable cells in the prepared samples $n_u(\text{sample})$.

The mean values of $n_u(\text{measured})$ and the associated standard deviation are plotted in the figure. The figure shows that the actual fraction of poorly deformable cells represented by the dashed lines is very close to the estimated values. Furthermore, the actual fractions lie within the standard deviation of the measured n_u .

5. Discussion

The relationship between cell shapes and intensity pattern in the ektacytometer is not straightforward if the blood sample consists of a mixture of deformable and poorly deformable

red blood cells. Both our simulations and experimental results reveal that the iso-intensity curves of the cell mixtures have cross-like shapes. Consequently, the usually employed deformation index DI , which is based on elliptical iso-intensity curves in the intensity pattern, is not the correct parameter to use in this situation. Therefore we presented an alternative method to analyze these intensity patterns which gives accurate quantitative information about the fraction poorly deformable cells in a red cell population.

In a former paper we showed that in a blood sample with normal red blood cells the iso-intensity curves are elliptical [19]. Moreover, at high shear stresses, the observed axial ratio of the iso-intensity curves of a cell population equals the axial ratio of a pattern which would be produced by a single red blood cell with the average volume of the cells in such a population [10]. On the other hand, the iso-intensity curves of a mixture of deformable and poorly deformable red blood cells are not elliptical any more and the axial ratio and the shape of the curves depend on the intensity level (Figs. 2-4). Although deformation index DI will be related to the composition of the red cell suspension, it gives no accurate quantitative information about the fraction poorly deformable cells in the cell population since the resulting DI depends on the intensity level of the iso-intensity curves.

With the method that is presented in this paper it is possible to obtain the fraction of poorly deformable cells from the intensity pattern accurately. As is shown in Fig. 5, there is a good comparison between n_u obtained by our method and the n_u of the prepared samples. The standard deviation in the measured n_u never exceeds 3%. Apparently, the intensity pattern contains sufficient information in order to allow discrimination between the different mixtures of deformable and poorly deformable cells.

These results point out that our method is potentially useful for the determination of the fraction of poorly deformable red blood cells in sickle cell disease or malaria. By creating a matrix \mathbf{I}_{mat} that contains one column with the intensity pattern of a suspension with only sickled cells and a second row containing the intensity pattern with only deformable cells, it should be possible to obtain the amount of sickled cells in blood samples of sickle cell patients. Once this technique appears to be applicable for sickle cells, a variety of experiments are possible to study the sickling behavior of cells from patients with sickle cell disease. In experiments with blood samples containing sickle cells using the standard ektacytometer setup [14] a strong dependence of DI is observed by changing the oxygen tension (pO_2) and pH. With our method we expect that it will be possible to study the dependencies on pO_2 and pH with the actual fraction of sickled cells (n_u) as a parameter instead of measuring the less appropriate DI .

For the estimation of the fraction of poorly deformable cells we used intensity patterns of measured intensity patterns with two distinct values of q related to poorly deformed cells and maximally deformed cells. In future research it is interesting to investigate the possibility to incorporate the intensity patterns of more than two elementary particles with different axial ratios q . The advantage would be a more detailed picture of the relative amounts of cells as a function of q . However, if the number of elementary populations becomes too large, the inversion (Eq. (4)) may be unstable due to column degeneracy of \mathbf{I}_{mat} .

In this paper we showed that it is feasible to analyze intensity patterns in an ektacytometer for a mixture of deformable and poorly deformable red blood cells. Our approach allows detection of the physiologically important fraction of poorly deformable red blood cells directly from the observed intensity pattern. This quantitative measure will be important for the study of the sickling behavior of sickle cells and parasitemia in malaria and may be a valuable tool in diagnoses and therapeutic control in these diseases.