

Detmold School at Zeche Zollverein  
Contributions to the Docomomo  
virtual exhibition - momove 2022

move

# Modern Movement and Industrial Heritage

Uta Pottgiesser, Anica Dragutinovic (Eds.)

mo

# momove

Modern Movement and Industrial Heritage

Contributions to the  
Docomomo virtual exhibition - momove

in collaboration with the  
19th Docomomo Germany Conference 2022  
at Zeche Zollverein



Figure 1

---

**INTRODUCTION**

**06 PREFACE**

- UTA POTTGIESSER, ANICA DRAGUTINOVIC

---

**INTERVIEW**

**08 INTERVIEW / Q&A**

- HANS-PETER NOLL, STEFAN RÖMER

---

**ESSAYS**

**14 INDUSTRIAL HERITAGE IN EUROPE:  
SHIFTS, CHALLENGES AND OPPORTUNITIES**

- DORA CHATZI-RODOPOLOU

**20 ZOLLVEREIN'S HISTORY OF RE-USE**

- KURT C. REINHARDT

**24 CONCOM AND MOMOVE.  
APPROACHES TO INDUSTRIAL HERITAGE**

- UTA POTTGIESSER, ANICA DRAGUTINOVIC

---

**EXHIBITS**

**RE-USE, BIODIVERSITY, EMBODIED AND  
RENEWABLE ENERGY**

**30 THE INDUSTRIAL HERITAGE  
QUARTET**

- ANISSA SOFIA KRAIN, VIONA MARX, IRINA  
MIROSCHNITSCHENKO & BUKET YOLERI

**34 ADAPTIVE REUSE OF A WORLD  
HERITAGE SITE**

- SOUMIA EL MOURABIT, SHASHI KARMAKER  
& RUTVI VARIA

**38 SUSTAINABLE REFURBISHMENT  
OF ZOLLVEREIN SCHOOL OF MANAGEMENT,  
ESSEN, GERMANY**

- CEM ÜNAL & PRAJITH GORENTLA

**42 BIODIVERSITY AT ZOLLVEREIN**

- KEN TIETJEN, NIZAR FANARI, PAUL HEIS-  
TERMANN & FADI KHAMAM

**46 ZOLLVEREIN EMBODIED ENERGY:  
SALT FACTORY CASE STUDY**

- ARDALAN MIRHADINEJADFARD, HYEONJI SEOL,  
SAHAR HEIDARI & TINA SAFARHAMIDI

**50 THE REVIVAL OF THE WORLD'S  
FIRST SOLAR POWER PLANT  
IN EGYPT**

- AHMAD ELNOSSERY, BASIM AL-MOUSA  
& MAHMOUD ABDELGHANY

**DOCUMENTATION, VISUALISATION, DIGITISA-  
TION AND GAMIFICATION**

**54 MECHANICAL SYSTEMS IN  
ARCHITECTURE**

- BENEDICT NEISE, JESSICA MOLDENHAUER  
& VITALIJ GÖTTMANN

**58 GROPIUS' FAGUS WERK  
AESTHETICS**

- LEON KONSCHAKE, MAXIMILIAN KIRCHHOFF  
& LEON LANDWEHR

**62 INTRODUCTION TO THE AESTHE-  
TICS OF THE ZOLLVEREIN COL-  
LIERY SCHACHT XII**

- REGINA KLIPPENSTEIN, LENA BECKERVORDER-  
SANDFORTH, ANDRÉ POPP & FRAUKE FISCHER

**66 DIGITALIZATION HERITAGE BUIL-  
DING WITH PHOTOGRAMMETRY**

- CHARNELE LUKMAN & MAHAN MASHAYEKH

**70 DISSEMINATING KNOWLEDGE  
OF MINING PROCESS/ACTIVITIES AT  
ZOLLVEREIN USING VIDEO GAMES**

- ANDRES BUITRAGO & GIZEM DEMIRHAN

**74 MUMBAI TEXTILE MILLS, RE-USE  
& RECOGNITION**

- ASHLEY GROVER, GODO ZABUR SINGH,  
PUREE SRISUK & JUNAID NASIR

---

**INFO**

**78 AUTHOR'S BIOGRAPHIES**

---

## PREFACE

Uta Pottgiesser & Anica Dragutinovic



Documentation, digitalization and dissemination of knowledge about buildings and sites of Modern Movement, and in particular industrial heritage, have been in the focus of this year's MoMove publication. The publication is a collection of the students' exhibits, developed by the students of the Master's programs of Integrated Architectural Design (MIAD) and Integrated Design (MID) in the academic year 2021/22, within the Conference and Communication (ConCom) course at the Detmold School of Architecture and Interior Architecture (TH OWL), and as a part of the 19th Docomomo Germany Conference 2022, Zeche Zollverein, Essen. As a co-organizer of the Docomomo Germany Conferences since 2019, the Detmold School was able to connect research and educational projects to the events, often exploring novel forms of ideation, documentation, design and dissemination. This publication complements MoMove publication developed in the academic year 2020/21 on the Modern Movement and Infrastructure theme (Pottgiesser et al., 2021).

The students' exhibits presented in this publication showcase and apply current digital visualization and communication technologies, such as: websites, apps, films, as well as applications of 360-degree images, virtual reality and gamification. They exploit the creative and novel digital potentials for the safeguard of the recent built heritage: preservation through VR and 3D-models (e.g. Mumbai Textile Mills, Mechanical systems), commemorating (e.g. Zollverein Game and Solar Power Plant Revival), community engagement and data accessibility (e.g. Digitalization of the Heritage Buildings with Photogrammetry and Industrial Heritage Quartet). Moreover, the exhibits demonstrate the students' reflections and concerns towards the future design and reuse of the industrial heritage, buildings and sites, inspired by the lessons learnt from Modern Movement, addressing the topics such as: redevelopment and sustainable renovation (e.g. Sustainable refurbishment of Sanaa-Cube and Adaptive reuse of Zollverein), embedded energy (e.g. Zollverein Salt Factory), sustainable materials and energy efficiency, biodiversity and landscape (e.g. Biodiversity at Zollverein), aesthetics and building analysis (e.g. Fagus Werk and Zollverein Aesthetics).

The contributions aimed to create new content for the Docomomo virtual exhibition – MoMove, developed by Docomomo International in 2015 (<http://exhibition.docomomo.com/>) with the goal of fostering its role as an international platform making the knowledge and information about the architectural heritage of the Modern Movement available online. We hope to inspire you as a reader and visitor.

**Figure 1:**  
Voss, Svenja-Christin (2022) Zeche Zollverein.

**Figure 2:**  
Voss, Svenja-Christin (2022) Riesenrad, Zeche Zollverein.

### References

MoMove. (2021). Docomomo virtual exhibition. <http://exhibition.docomomo.com/>.

Pottgiesser, U., Dragutinovic, A., & Loddio, M. (Eds.). (2021). MoMove Modern Movement and Infrastructure. Presented at the 18th Docomomo Germany Conference, Dessau, Bauhaus (online): Technische Hochschule Ostwestfalen-Lippe. <https://doi.org/10.25644/3m9j-0f94>

Figure 2

## Q&A, ZOLLVEREIN FOUNDATION

HANS-PETER NOLL & STEFAN RÖMER



Figure 1

**Q:**

Hans-Peter Noll, congratulations, in 2021 Zollverein had its 20th anniversary as a World Heritage Site. What were the main criteria of nomination?

**A:**

The Zollverein XII Coal Mine Industrial Complex is an important example of a European primary industry of great economic significance in the 19th and 20th century. It consists of the complete installations of a historical coal-mining site: the pits, coking plants, railway lines, pit heaps, miner's housing and consumer and welfare facilities. The mine is especially noteworthy of the high architectural quality of its buildings of the Modern Movement.

Zollverein XII was created at the end of a phase of political and economic upheaval and change in Germany, which was represented aesthetically in the transition from Expressionism to Cubism and Functionalism. At the same time, Zollverein XII—built from 1928-32—embodies this short economic boom between the two World Wars, which has gone down in history as the “Roaring Twenties.” Zollverein is also, and by no means least, a monument of industrial history reflecting an era, in which, for the first time, globalization and the worldwide interdependence of economic factors played a vital part. The architects Fritz Schupp and Martin Kremmer developed Zollverein XII in the graphic language of the Bauhaus as a group of buildings which combined form and function in a masterly way.

**Q:**

Stefan Römer. The former industrial architecture and technical systems are now used for several purposes. Are there any strategic guidelines for developing Zollverein in the future?

**A:**

Three guidelines were formulated to serve as the framework for the future management of the Zollverein UNESCO World Heritage Site and as a future vision for its sensitive and sustainable further development. The basis is the Outstanding Universal Value (OUV) of the World Heritage Site. The exceptional characteristics described in these guidelines, which express the OUV, must be conserved, developed and passed on as world heritage for future generations (<https://whc.unesco.org/en/list/975/>). These tasks have therefore been anchored in the statutes of the Zollverein Foundation as the basic framework for its activities, and can be summarized as follows

“Zollverein UNESCO World Heritage Site – unique in design, transformation and innovation – yesterday, today and tomorrow.”

**Figure 1:**  
Voß, Svenja-Christin (2022) Zeche Zollverein.

**Figure 2:**  
UNESCO-Welterbe Zollverein Map. © Zollverein

**Figure 3:**  
Jochen Tack (2014). Zollverein Coal Mine Industrial Complex in Essen. © Stiftung Zollverein

**Figure 4:**  
Jochen Tack (2016). Complexe industriel de la mine de charbon de Zollverein à Essen. © Stiftung Zollverein

**Figure 5:**  
Jochen Tack (2014). Zollverein Coal Mine Industrial Complex in Essen (Eisbahn auf der Kokerei). © Stiftung Zollverein

**Figure 6:**  
Frank Vinken (2010). Zollverein Coal Mine Industrial Complex in Essen (Das RuhrMuseum in der Kohlenwäsche der ehemaligen Zeche Zollverein in Essen ist eröffnet). © Stiftung Zollverein

**Q:** Stefan Röner, In 2001 Rem Kolhaas and OMA developed a master plan for Zollverein. Are you still following this concept or has it been modified?

**A:** In the autumn of 2001, the predecessor company to the Zollverein Foundation commissioned the renowned Dutch architectural and urban planning firm Office for Metropolitan Architecture (OMA) with developing the Master Plan referred to above for the development at Shaft XII, Shaft 1/2/8 and the Zollverein Coking Plant. In parallel, and in close collaboration with OMA, Reinhard Roseneck of the German National Committee of the International Council on Monuments and Sites (ICOMOS) developed the Monument Preservation Master Plan for the site, as also referred to above, based on the principles: Preserve, Use, Communicate. The focus of the joint work was the issue of how to unite monument protection, communication work and new construction projects in an urban development concept, and at the same time upgrade the neighbouring districts.

The aim of the OMA Master Plan was to develop Zollverein as a dynamic centre in the region and an attractive destination for visitors. The protected ensemble of the Coal Mine and Coking Plant in the central area, including the railway tracks, belt bridges and green structures was to be preserved, and the overall site not altered as a result. At the same time, new buildings for the periphery of the area were planned, in particular in the area of Shaft 1/2/8 and the Coking Plant.

The central element of this Master Plan is an outer ring that unites the edges of the site and encloses the listed ensemble at its core: the Walled City. To create transitions and connections between this belt zone and the adjoining districts of the city, Rem Koolhaas envisaged a visitor centre, a design school and a

conference centre as three so-called attractors. These were intended as buildings of outstanding design with uses that have an impact on the public realm which on the one hand should visibly distinguish themselves from the existing historical buildings, and on the other hand emphasize the transition from the World Heritage Site to the surrounding area. Rem Koolhaas interpreted the many railway tracks, pipes and belt bridges on the site as important elements of the listed ensemble, because they create a visible connection between the Shaft Sites and the Coking Plant, and at the same time must be preserved to provide an understanding of the production

processes and inter-relationships. The track system that connects the production sites was reinterpreted as a space for the expected stream of visitors to move around in. At the same time, it was important to give the industrial nature, which had spread unhindered on the site since the closure of the Coal Mine and Coking Plant, sufficient space, while ensuring the industrial architecture did not become overgrown.

Rem Koolhaas' urban development Master Plan and the Monument Preservation Master Plan developed by Reinhard Roseneck were presented in the spring of 2002. Necessary amendments were made over the course of the years, but the broad lines of the Master Plans still form the basis for all construction activities at the Zollverein World Heritage Site.

**Q:** Hans-Peter Noll, In the future, it will be particularly important to avoid conflicts between the obligation to preserve and the sustainable further development of Zollverein, and to increase the knowledge and understanding of the special qualities of the site both among the residents of the neighbouring districts and among visitors. Can you tell something about your further procedure?

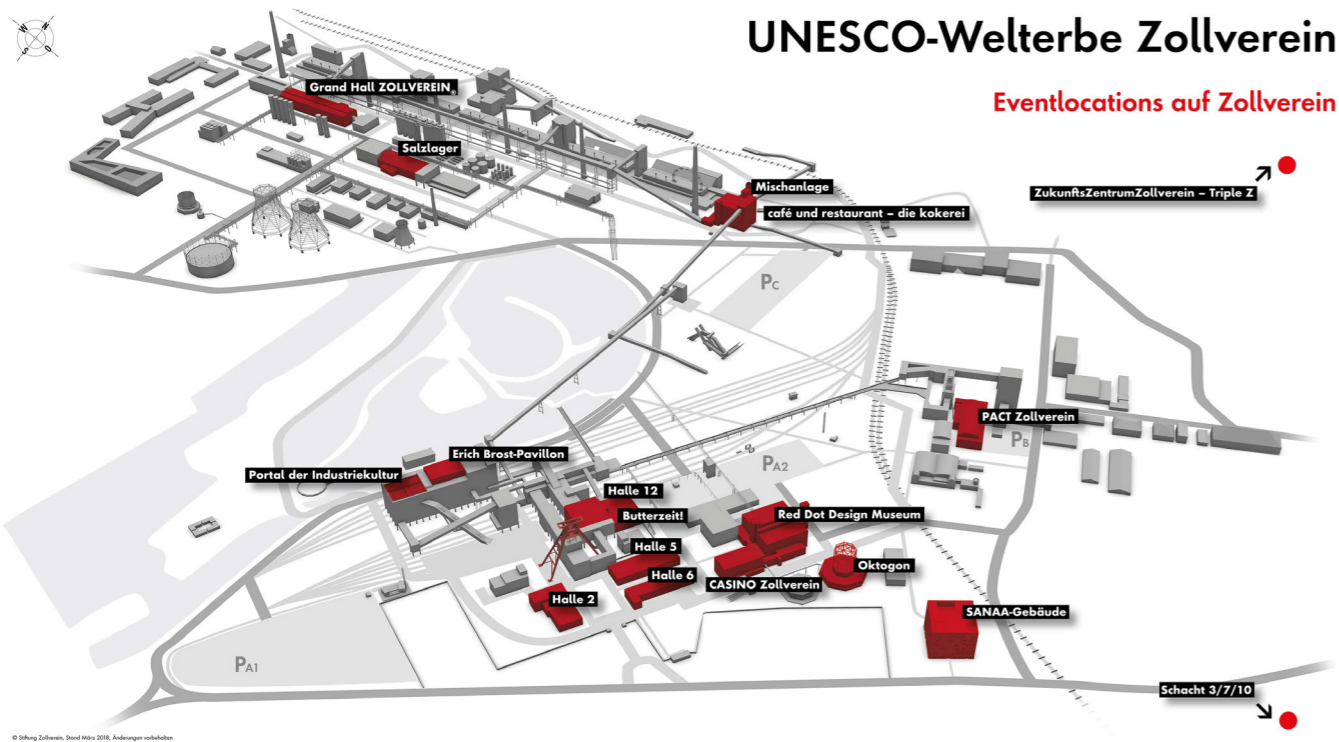

Figure 2



Figure 3



Figure 4



Figure 5

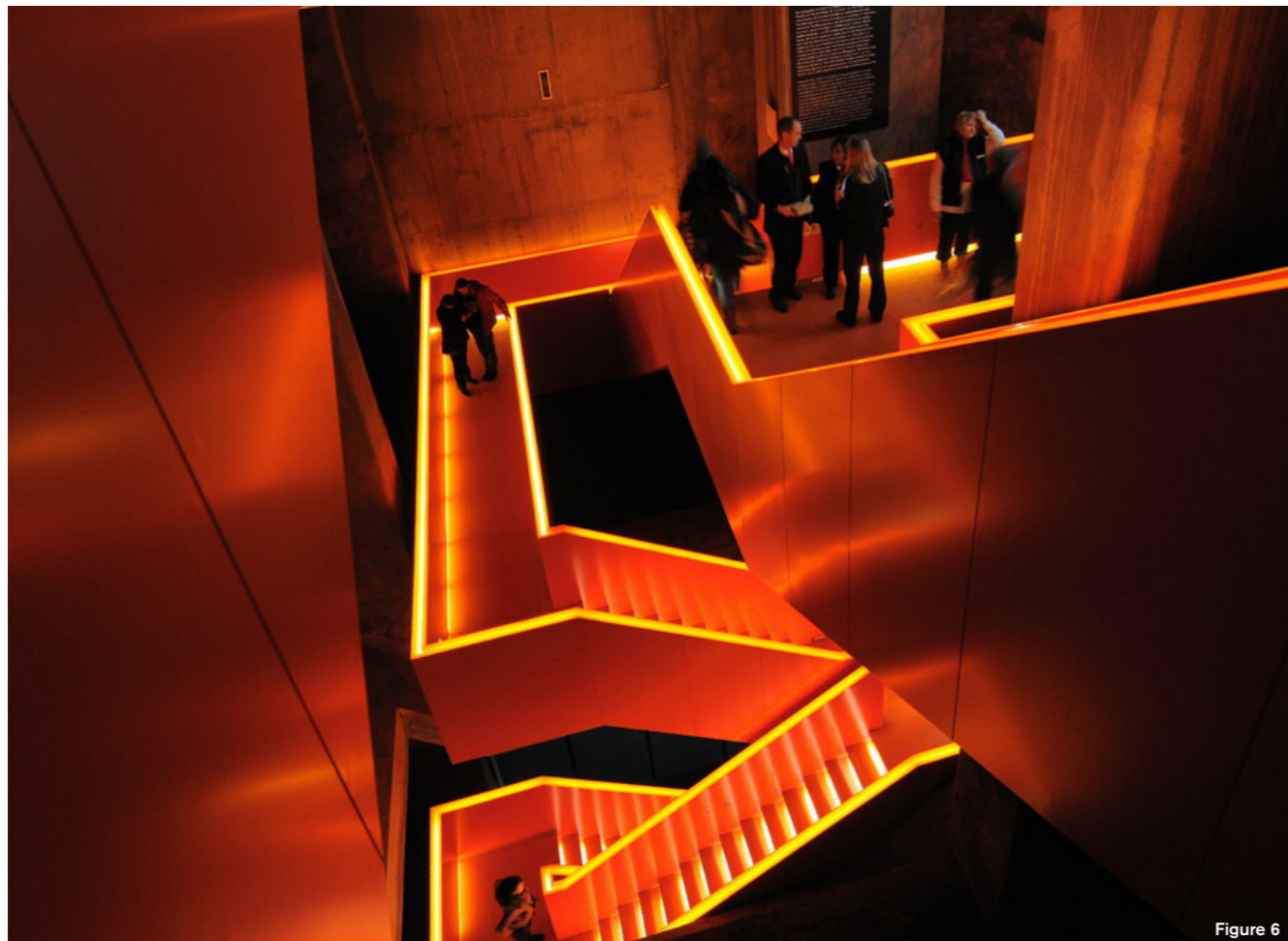

Figure 6

**A:**

The focus of all fields of action and measures implemented at the Zollverein UNESCO World Heritage Site lies on securing and conservation, on sensitive and sustainable further development and on communication of the site's special qualities. Key topical fields of action have been developed for the tasks of conservation, development and communication. These fields are: 1) Monument and World Heritage, 2) Transformation and innovation, 3) Education and tourism, 4) Zollverein and the quarter and 5) Nature and species protection.

**Q:**

Stefan Römer: Tourism is considered to be a driver for the management of World Heritage Sites. Which role does it play at Zollverein?

**A:**

As the first and currently the only World Heritage Site in the Ruhr region, the Zollverein industrial monument attracts around 1.5 million visitors annually, making it the second most visited cultural tourist attraction in North Rhine-Westphalia after Cologne Cathedral. At present, there is no indication that the effects of tourism will result in concrete threats or impairments to the World Heritage Site. The range of events and the current visitor numbers mean that it is essential to provide effective signage and lighting, appropriate to a monument.

The Zollverein UNESCO World Heritage Site is a fixed element of tourism marketing in the Ruhr region. It is, however, necessary to ensure through continuous monitoring that a balance is maintained between tourist use and the conservation of the building fabric and public spaces in accordance with monument protection.

The aim of the UNESCO World Heritage Convention is to identify, protect and use the most important cultural and natural heritage of humanity for intercultural communication. World Heritage Sites are inscribed on the World Heritage List to preserve them for future generations. In this sense, UNESCO World Heritage Sites are educational sites whose main task is to communicate the Outstanding Universal Value (OUV). This includes transparent communication of the strategies implemented at the Zollverein UNESCO World Heritage Site to conserve the industrial monument in harmony with its sustainable transformation. In the future, all tourist attractions at the Zollverein World Heritage Site should therefore also serve to communicate the OUV in a target audience-specific way. The Zollverein UNESCO World Heritage Site has been pioneering in monument protection and conversion as a venue a historical industrial site. Despite many successes, however, it is still under great pressure to develop. Other industrial monuments face similar challenges. Fostering continuous exchange of knowledge with the operators of other World Heritage Sites and industrial monuments is therefore important. Exchange with other World Heritage Sites such as the Völklinger Hütte in Saarland or the Hansa Coking Plant industrial monument in Dortmund should be intensified, in particular with respect to the challenges of conservation. At the international level too, collaboration with comparable (World Heritage) Sites should be further intensified.

During the course of the year, various events are held at the Zollverein UNESCO World Heritage Site, some of which are intended to appeal to an international audience. Since 2005, World Heritage Day has been celebrated annually on the first Sunday in June and is marked with events at all World Heritage Sites. It began in Germany on the initiative of the German UNESCO Commission and the German UNESCO World Heritage Sites Association (UNESCO-Welterbestätten Deutsch-

land e.V.). The UNESCO Zollverein World Heritage Site has been involved since the inaugural event in 2005, and has invited countless visitors to events at the site. Communication opportunities still need to be further streamlined, adapted and made more international. The use of digital technologies and media will become increasingly important in the future. Existing attractions are constantly updated and supplemented with new content. One example that can be mentioned is the collaboration with the Google Arts& Culture project: In its context, the Zollverein UNESCO World Heritage Site will be presented digitally in the future. The exhibition 'Survivors. Faces of Life after the Holocaust' attracted wide international media attention. The aim is to establish the Zollverein UNESCO World Heritage Site as a venue for exhibition formats with international appeal in order to strengthen the perception of the Zollverein UNESCO World Heritage Site outside Germany. There is also a free app that is continually being further developed. Core functions make both orientation and navigation across the extensive site easier and provide information about the history of the site. Augmented Reality (AR) functions deliver information about the World Heritage Site in an up-to-date way and without constructional measures. In particular, digital solutions should also take into account the increasingly number of international visitors.

**Q:**

Hans-Peter Noll: Is there anything else you like to share with us? Maybe a future vision?

**A:**

Building on the successful preliminary construction and structural achievements over the past 30 years, the Zollverein UNESCO World Heritage Site now needs to be transformed, through sensitive and contemporary further development, into a model location that reflects the requirements of a modern and diverse society sustainably and innovatively. The Zollverein UNESCO World Heritage Site brings to life the past, present and future of the place itself, as well as of the City of Essen and the entire Ruhr region. The Zollverein UNESCO World Heritage Site has established itself in the city community as an identity-forming monument, a place of remembrance and a venue for events and leisure activities. The location offers exceptional quality as a place to spend time and facilities to attract tourists. Excellent design of all structural and other projects for the further development of the Zollverein UNESCO World Heritage is a fundamental quality feature. The Zollverein UNESCO World Heritage Site is, in its monument-compliant preservation coupled with structural development with a focus on quality, an exemplary location for the sensitive and sustainable transformation of an industrial World Heritage Site. By implementing a World Heritage-compliant conservation, renovation and development strategy, the conversion of the existing buildings and the development of the available areas were carefully advanced: The key players are also committed to this approach. With the engagement of all the relevant stakeholders, the OUV and thus the World Heritage status are permanently secured with the help of quality-focused World Heritage Site management. At the Zollverein UNESCO World Heritage Site, visitors from all over the world can learn about the heritage of the coal and steel history and of the Coal Mine and Coking Plant as well as the entire Ruhr region with the help of a modern and digitally supported communication concept. The site is a central anchor point for the European Route of Industrial Heritage (ERIH), and for communicating the industrial history of the Ruhr region and of Germany as well as Europe.

# INDUSTRIAL HERITAGE IN EUROPE: SHIFTS, CHALLENGES AND OPPORTUNITIES

THEODORA CHATZI RODOPOULOU



**Figure 1**  
The TextielMuseum housed in the former textile mill C. Mommers & co. The conversion of the 19th cent. mill into a museum of textiles is one of the earliest industrial heritage reuse cases in the Netherlands. In the turn of the 21st century the transformed complex started facing problems of functional, social and aesthetic obsolescence. In 2008 a new building was added to the historic complex for housing the growing activities of the museum, refreshing its image and reflecting its dynamism.

The legacy of industrialisation counts only a few decades of being accepted as cultural heritage. In Europe, the change of perceptions over its connotation and significance, from a menace to historic landscapes to an outstanding historical resource, took place at a different pace in each country. Progressively since the 1960s, the former industrial sites have been attracting civic and institutional attention. Systematic research, survey and documentation initiatives of historic industrial sites over the years have given a better view of this heritage group, contributing in its improved protection and management as well as in its recognition and acceptance as part of cultural heritage across Europe.

## Shifts

Early attempts to conserve Industrial Heritage in Europe mainly involved its transformation into museums. Very soon though, it became obvious that alternative ways were required in order to respond to the scale and particularities of this new heritage group. Since the late 1970s, adaptive reuse a process of altering a site so that it is suitable to house a new function while preserving its cultural significance was employed for prolonging the life of industrial relics. Today industrial heritage reuse, has become a widely employed practice, which has allowed European countries to turn a serious socio-spatial and economic problem into an opportunity.

The shifts noted overtime with respect to industrial heritage reuse are evident in multiple facets of the practice, including the scale of intervention, the range of new functions, the selected building typologies, the intervention approaches and the attitude against the various heritage dimensions. The spectrum of industrial heritage reuse schemes has moved overtime from mono-functional to multifunctional projects; from single building interventions to landscape approaches; from conversions of mills and factories to the transformation of more intricate complexes, such as extraction sites and installations; from adaptations of modest pre-industrial sites to 20th century industrial relics and industries in operation; from restoration approaches to compatible or radical interventions and from the focus on tangible assets to a wider emphasis on intangible values, too.

## Current challenges

In the 21st century the European industrial heritage faces an array of challenges. Some of them are common for all European nations while others concern only a handful of countries that share similar levels of administrative organization or comparable levels of maturity in the care of their historic industrial stock.

**Figure 1**  
Ton Eppenhof.

**Figure 2**  
Granary Square, Kings Cross Central - Panorama" by mattk1979 is marked with CC BY-SA 2.0.

**Figure 3**  
Sunset lights up King's Cross Central" by marc.barrot is marked with CC BY-NC-ND 2.0.

**Figure 4**  
Archive D. Chatzi Rodopoulou.

**Figure 5**  
LaFabrika detodalavida – Revitalising a rural area (2017). [https://cooperativerativecity.org/2017/06/28/lafabrika-detodalavida](https://cooperativecity.org/2017/06/28/lafabrika-detodalavida).

**Figure 6**  
Archive D. Chatzi Rodopoulou.





**Figure 1** Industrial heritage-led regeneration: the case of King's Cross Central in London. The mega redevelopment project has turned a stigmatised area into a hotspot in the heart of the British capital, preserving multiple former industrial buildings and converting them into an array of functions, including educational, residential, commercial, office, leisure and other uses.



**Figure 2** Former gasholders transformed into luxury housing, as part of the ambitious urban regeneration project of King's Cross Central in London.



**Figure 3** The commercialisation of heritage assets is an intrinsic feature of the new mega-development. The new housing offered is addressed in its vast majority to the higher social strata of London, leading to phenomena of exclusion and displacement.

A common dual challenge across Europe is to continue using industrial brownfields as valuable vectors of progress while upkeeping the large volume of the converted sites that have been placed at risk under the volatile socioeconomic conditions of the last decades. Countries such as the United Kingdom, Germany, France and Belgium have been facing this issue since the early 2000s, when their early converted industrial heritage sites started reaching the point of physical, social, functional, legal and economic obsolescence once again. Countries like the Netherlands, Italy, Spain, Greece and Portugal were presented mainly with the problem of economic obsolescence from the late 2000s, due to the repercussions of the global financial crisis.

Another issue which also relates to the financial crisis and has been aggravated by the Covid pandemic, is that all European countries are expected to do more with less. This has a serious impact not only on the practice of adaptation, but also on the protection of the heritage stock.

Finally, a serious topical challenge is the pursuit of conservation strategies that are not only financially sound but also environmentally and socially sustainable. Every intervention in the historic industrial stock needs to aim for an improved environmental performance and a durable result. Furthermore,

industrial heritage-led regeneration in the historic European cities needs to generate benefits for a wider social base, avoiding phenomena of gentrification, displacement and exclusion (Fig.2, Fig.3).

Apart from the common issues mentioned above each nation has to respond to challenges of a distinct nature. The administrative fragmentation and the organisation of heritage care on a regional level appears to be an important obstacle to the evolution of care of industrial heritage and often results in the lack of an overview of historic former industrial sites, necessary for their effective protection and management. This problem is evident mainly in countries like Spain. Furthermore, the contraction of the State interventionism and the decentralisation of heritage care a phenomenon more prominent in countries like the United Kingdom, the Netherlands and Spain exposes the vulnerable aspects of industrial heritage both before and during its reuse at risk. The lack of a comprehensive record of industrial heritage assets and the absence of a systematic selection process, which still characterise countries like Greece and Spain, do not allow an overview of the available heritage stock. The latter is necessary as it can lead to proper protection and well-substantiated reuse schemes, through informed evaluation (Chatzi Rodopoulou, 2020).

**Opportunities**

The last decades have seen our cities affected by exponential developments, pressing for the reinvention of their physical and social environment. Industrial heritage reuse has been proven a valuable instrument of the required multifaceted transformation. Therefore, the practice has the potential to reload with new energy the former industrial cities that still struggle with the issues of dereliction and obsolescence. Industrial heritage-led regeneration can catalyse the development of stigmatised city centres as well as remote areas, restore their economy and contribute to the generation of growth and the creation of jobs, turning derelict sites into lively and productive spaces (Fig.1). It can also play a significant role in the green transformation of our continent and help achieve the goals set in the new European Bauhaus agenda (EU, n.d.). In order to reach those goals and tackle some of the challenges mentioned above however, the approach on industrial heritage transformation needs to be adjusted, becoming both more durable and more inclusive.

In regard to the issue of environmental sustainability, the manufacture of new materials, techniques and building systems creates opportunities for the development of more durable and environmentally sensitive schemes. Renewable and compatible materials used in industrial heritage reuse practice can contribute to energy efficient and low maintenance buildings. Understanding the existing structure and grasping its atmosphere as well as mastering the advances in the field of building technology is necessary in order to strike a proper balance between the enhanced energy performance and the preservation of the cultural significance when reusing historic industrial sites (van Hees et al., 2014).

With respect to the issue of social sustainability of industrial heritage reuse projects, some steps have already been taken. The financial crisis, despite its significant far reaching negative consequences, has served as an opportunity for a paradigm shift on heritage redevelopment (Chatzi Rodopoulou, 2019).

With private and public institutions paralyzed from the austerity, other players who challenged the hegemony of the dominant system surfaced, offering a new life to complex heritage sites, like the industrial ones. In many European countries there is a general pattern of growing civic involvement in the reuse of vacant heritage assets that highlights the innovation capacity of NGOs and bottom-up initiatives (Polyák et al., 2019). This alternative heritage care and management model shows great potential for a better and more sustainable direction of heritage care in European countries that suffer from the nuanced effects of the prolonged financial crisis, this model could provide an ideal solution for a great number of industrial relics in public ownership, that are entrapped today in the demolition or commercialisation dipole. It can put a halt to the abandonment, decay and vacancy of a significant part of the industrial heritage stock located either in an urban or in a rural setting, and its hasty sale to commercial developers or private parties that often leads to intrusive interventions and commercialization.

Furthermore, this model can empower local communities to reshape their inherited industrial assets, making them part of the solution rather than reactive recipients of top-down decisions. The bottom-up industrial heritage reuse approach offers opportunities of inclusion and integration of vulnerable social groups, it can strengthen the social cohesion of the local community, restore its pride and create a strong bond with its 'inherited' assets, inhibiting phenomena of gentrification and exclusion.

However complex and demanding the venture, the bottom-up reuse model is definitely a promising alternative for the alleviation of the urgent and multileveled problem of industrial heritage care and management in Europe. Questioning obsolete practices and being open to innovative, inclusive and socio-culturally sensitive approaches of dealing with our historic environment is an essential step towards a sustainable direction of development of Europe, which is certainly worth taking.



**Figure 4** LaFabrika detodalavida before and after its renovation. LaFabrika detodalavida is located in Extremadura in Spain and it is housed in the former Asland cement factory. It is run by a collective and since 2017 it functions as an open participation space for collaboration with a creative, social and cultural content. It offers a wide variety of activities including events, lectures and workshops; an open-air cinema as well as programmes and processes based on collaborative social management and communal social action that are centred around the needs of the local community.

## References

Chatzi Rodopoulou T., 2020. Control Shift. European Industrial Heritage Reuse in Review. A+BE | Architecture and the Built Environment, n. 13, p. 1-630, ISSN 2214-7233. [Online]. Available: <<https://journals.open.tudelft.nl/abe/article/view/5195>> [Accessed 4-4-2022].

Chatzi Rodopoulou, T. 2019. "The opportunities of Crisis. Bottom-up initiatives for the reuse of industrial heritage: The example of the Tabacalera in Madrid." in Proceedings of the International Conference on Changing Cities IV: Spatial, Design, Landscape & Socio-economic Dimensions, Chania, Crete, Greece, June 24-29, 2019, pp. 486-497.

EU, n.d. New European Bauhaus. [Online]. Available: [https://europa.eu/new-european-bauhaus/index\\_en](https://europa.eu/new-european-bauhaus/index_en) [Accessed 4-4-2022].

Polyák, L. et al, 2019. "Observatory Cases Report" in: Open-Heritage, Organizing, Promoting and Enabling Heritage Re-use through Inclusion, Technology, Access, Governance and Empowerment, H2020 PROJECT, [Online]. Available: <https://open-heritage.eu/> [Accessed 16-12-2021].

van Hees, R, Naldini, S. & Roos, J. 2014. Durable past-sustainable future, Delft, TUDelft - Heritage and Architecture.

**Figure 6**

The former gasworks of Athens in Greece have been converted into the vibrant multifunctional centre 'Technopolis'. Today the complex is one of the most popular venues in the city, housing a cultural centre, a museum of gasworks and an innovation hub.



# KALEIDOSCOPE ZOLLVEREIN

KURT C. REINHARDT



Figure 1

„The true mystery of the world is the visible, not the invisible.“ Oscar Wilde

The word kaleidoscope, which has its origins in the Greek language, translates as „to see beautiful shapes“. A kaleidoscope lets us see shapes in ever new combinations and permutations.

If one enters today's Zollverein World Heritage Site via the historical access situation from Gelsenkirchener Straße through the so-called Ehrenhof, the visitor is presented with a situation of strictly geometric cubic buildings. All buildings follow the same construction and design principles, so that no functional attribution is possible due to their uniformity. Only the striking silhouette of the fully-walled winding tower stands out recognizably in the central axis of the entrance. This is the first conveyor frame designed by the architect. The traditional construction method of such conveyors of the coal mining industry are filigree steel lattice constructions, which have no visual significance or graphic conciseness and are purely engineering constructions. The double trestle winding tower of Zollverein, on the other hand, was not only a design reminiscence of the function of this shaft as the central place of mining for the entire Zollverein coalfield, but is nowadays one of, if not the most frequently depicted, symbol of the Ruhr region.

This dual character as historical technical functionality and today's symbolism literally illustrates very well the hybrid perception of today's UNESCO World Heritage Site Zollverein. This becomes clear when one recalls that the entire ensemble was submitted to UNESCO as the largest coal mine in the world and was included in the list of World Heritage Sites in a completely different way.

UNESCO justifies/substantiates Zollverein's status as follows:

*„The Zollverein industrial complex in Land Nordrhein-Westfalen consists of the complete infrastructure of a historical coal-mining site, with some 20th-century buildings of outstanding architectural merit. It constitutes remarkable material evidence of the evolution and decline of an essential industry over the past 150 years.“*

*Criterion (ii): The Zollverein XII Coal Mine Industrial Complex is an exceptional industrial monument by virtue of the fact that its buildings are outstanding examples of the application of the design concepts of the Modern Movement in architecture in a wholly industrial context.*

*Criterion (iii): The technological and other structures of Zollverein XII is representative of a crucial period in the development of traditional heavy industries in Europe, when sympathetic and positive use was made of architectural designs of outstanding quality.“*

**Figure 1**  
Anton Meinholz. Fördermaschinenhalle © Stiftung Zollverein

**Figure 2**  
Anton Meinholz (1934). Werkstattgebäude und Kesselhaus mit Schornstein der Zeche Zollverein. © Stiftung Zollverein

Zollverein has thus been inscribed on the World Heritage List of Humanity primarily for its architectural design and urban composition and not for its historical, technical function.

Therefore, it is worth taking a brief look at the design principles. As already mentioned above, all the structures using the cube as their large form. With the exception of the winding tower and a chimney that no longer exists today.

On closer inspection, however, it is noticeable that despite all formal uniformity and material reduction, the actual facade design exhibits a tremendous differentiation and detailing. Almost no grid of the curtain wall is identical. There are only four visible related materials: brick, steel, wired glass and concrete. However, the variations in facade design are not a formal end in themselves, but support the viewer's perception and serve to visually extend axes, making them appear much more representative. The visual, graphic and spatial- architectural effect results from the coordinated compositions of the otherwise uniform and monochrome appearing building structures, to each other. The contrast of formal and material simplicity and design differentiation in detail is the essential feature, in addition to the monumental dimension of the complex.

This representational effect is an essential function of Shaft 12 within the overall ensemble, because it was not only intended to make operations more economical, but also to serve as a self-portrayal of the world's second-largest steel group at the time. Like the turbine hall of AEG in Berlin or The Technical Administration Building Höchst AG (archway building) in Frankfurt a.M. by Peter Behrens and the Fagus Works in Alfeld a.d.L. by Walter Gropius and Adolf Meier, Zollverein Shaft 12 is an incunabulum of identity-shaping corporate architecture in the industrial sector. This is not surprising in that one of Zollverein's two architects, Martin Kremmer, studied under Peter Behrens, who is credited with inventing the corporate identity. There is also evidence of a connection with the Deutscher Werkbund, also co-founded by Behrens, an initiative established in 1907 as an economic-cultural association of artists and entrepreneurs, both in the case of the client, the then chairman of the board of Vereinigte Stahlwerke Albert Vögler, and in the case of the two architects Fritz Schupp and Martin Kremmer. This, too, links Zollverein with the Fagus Factory or the Bauhaus, as well as with the Weissenhof estate or the Berlin Modernist estates in the UNESCO World Heritage Site. The mass medialization of architecture through congenial photography by Anton Meinholz or Albert Renger-Patzsch, for example, Zollverein also shares with the aforementioned buildings.

It is thanks to this architectural design with communicative effect, not to the technical historical function, that the buildings, which were only intended to have a temporary life span of 50 years, are now preserved as monuments. Here, the German word „Denkmal“ can also be understood as an imperative: Denk-Mal!

It is a stroke of luck that Zollverein is a UNESCO architectural monument. This gives preservation the possibility to accommodate new, refinancing uses through conversion of the interior of the buildings and not only to be conserved as a gigantic, costly to maintain, machine mausoleum.

The history of Zollverein's reception as a monument of the past coal and steel industry fills entire libraries and has dominated public perception to date. The investigation of the cultural, architectural and economic dimension is an, essentially still unprocessed, but very exciting research topic for present and future generations. So, in the best sense, a valuable heritage and a kaleidoscope of perceptions.

## References

Schnupp, F., Kremmer, M. (1929). *Architekt gegen oder und Ingenieur*. Berlin.

Chevallerie, H. de la. (2003). *Gebauter Gedanke - Zeche Zollverein Schaut XII in Essen*, Reihe Kunstort Ruhrgebiet, Klartext Essen

Pegels-Hellwig, K. (2012). *Bauten für die Industrie. Der zeichnerische Nachlass der Architekten Fritz Schupp und Martin Kremmer 1921 – 1971*, Bochum.

Renger-Patzsch, A. (1931). *Eisen und Stahl*, Albert Renger-Patzsch, Berlin Rechendorff

König, W. (2002). *Symmetrie und Symbol, Die Architektur von Fritz Schupp und Martin Kremmer, Wilhelm Busch und Torsten Scheer*. Köln.

Drebusch, G. (1977). *Industrie-Architektur*, Heyne Verlag, München.

Buddensieg, T., Glaser, H., Heidecker, G., Wilhelm, K., Bohle, S., Neumeyer, F. (1993). *Industriekultur: Peter Behrens und die AEG 1907-1914*, Gebr. Mann Verlag, Berlin.



# ConCom



2021/2022

## CONCOM AND MOMOVE. APPROACHES TO INDUSTRIAL HERITAGE

UTA POTTGIESSER & ANICA DRAGUTINOVIC

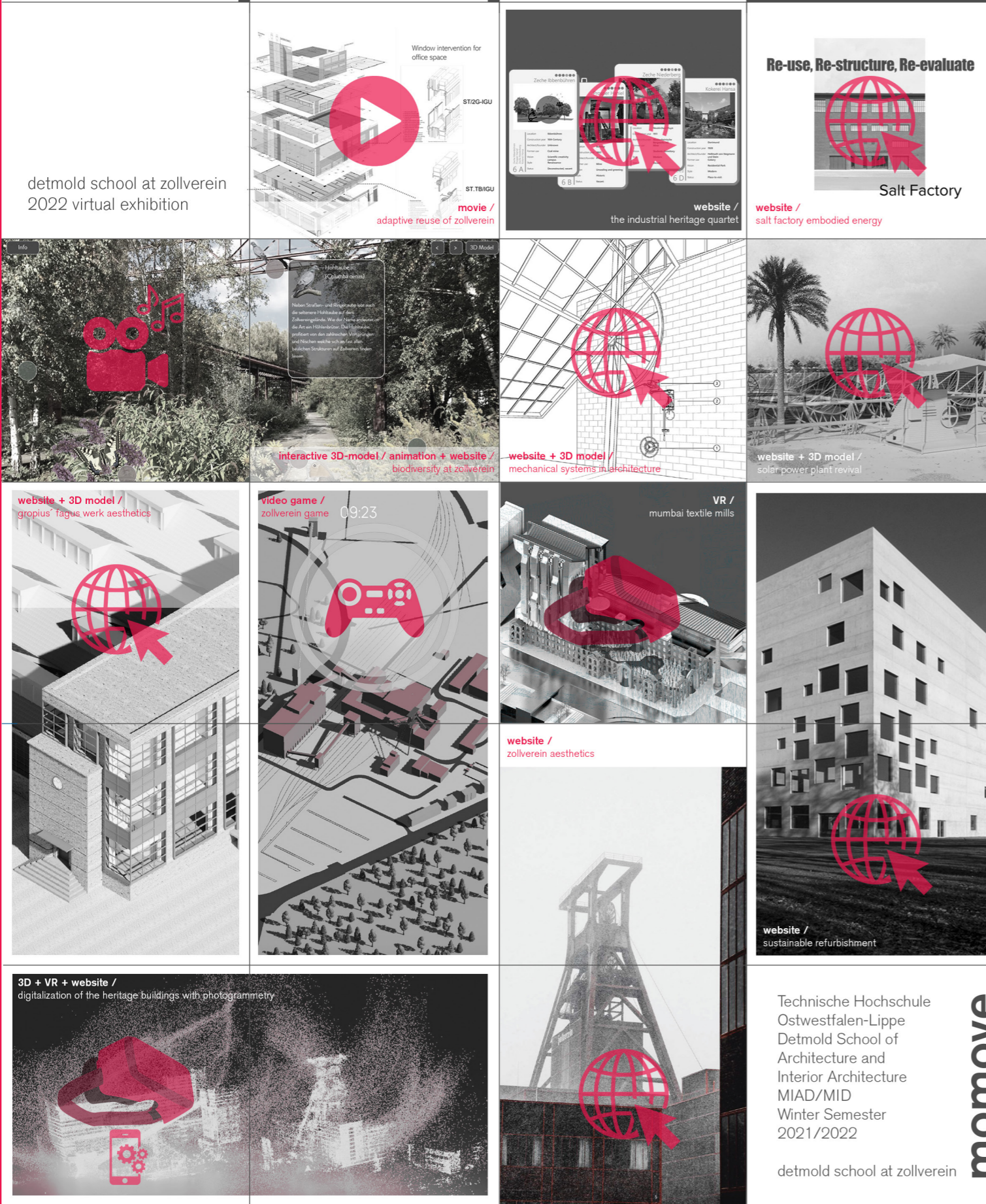

### Abstract

The Conference and Communication (ConCom) course at the Detmold School of Architecture and Interior Architecture (TH OWL) introduces students in the master's program to scientific work and pursues the goal of establishing a correlation between teaching and research. In particular, it is about conveying current knowledge and new findings in the form of the so-called non-written output (NWO) or non-traditional research output (NTR). ConCom tests innovative teaching and learning formats at the intersection of scholarly research and outreach in the field of the built environment, with a particular focus on cultural heritage, digital technology, and their societal impact. This has enabled the 40 students from many nations to conduct cross-cultural and cross-sectoral research in interdisciplinary and international teams. This diverse and low-threshold form of explorative dissemination increases the visibility of research findings and promotes their inclusive communication.

In the academic year 2021/22, the ConCom course took up the topic of the 19th DO-COMOMO Germany Conference "Modern Movement. Industrial Heritage thought ahead" organised in collaboration with Zollverein UNESCO World Heritage Site in Essen. The students were asked to research, document and interpret the topic of industrial heritage based on scientific articles, reports and publications (e.g. related to history, typologies, distribution, design, aesthetics and construction, spaces, transformation and reuse). Building on a literature review in the pre-semester, students choose specific topics related to modern industrial heritage and developed their theme in the context of the scientific conference. Complementing the contributions in the conference, ConCom served as a platform for students to explore Modern Movement's (MoMo) achievements around the world, but also to explore digital tools and their applicability for communicating research results (Fig. 1). On display are websites, apps, films as well as applications of 360 degree images, augmented and virtual reality and as such they are aiming to contribute to the DOCOMOMO Virtual Exhibition – MoMove (MoMove 2021).

### Categorisation and Conservation of Industrial Heritage

The non-profit organization DOCOMOMO International is dedicated to the documentation and conservation of buildings, sites and neighborhoods of the Modern Movement (DOCOMOMO International, 2021). Its currently 78 national or regional chapters are located on the five continents and they have developed individual formats and activities tailored to their specific needs. It focuses on investigation of all kind of buildings, sites and landscapes - still research and documentation of modern industrial heritage seems underrepresented in DOCOMOMO's portfolios. Reasons for this include that first industrial heritage dates back to the early years of industrialisation from 1750 until WWII in 1914. Those were the first sites in Europe to be closed down and abandoned since the 1960s, also giving birth to the discipline of industrial archaeology (Chatzi-Rodopolou, 2020). At that time large scale demolition was common practice and first recognition of buildings and sites as industrial heritage only started from 1980s onwards, establishing conservation and reuse projects.

**Figure 1:** Collage of student works in the ConCom course Industrial Heritage and media used. Illustration by the authors.

**Figure 2:** Damage Assessment of a window at Zollverein Cokery building. Illustration by Soumia El Mourabit, Shashi Karmaker and Rutvi Varia.

**Figure 3:** Window handle in modernist building in Coimbra, 2021. Photo by Uta Pottgiesser.

Technische Hochschule Ostwestfalen-Lippe  
Detmold School of Architecture and Interior Architecture  
MIAD/MID  
Winter Semester 2021/2022

detmold school at zollverein

momove

Figure 1



Figure 2

At the same time first industrial heritage site was inscribed as UNESCO World Heritage in 1978 (Poland), the first modern industrial site to be inscribed was the Zollverein Coal Mine Industrial Complex in Essen (Germany) in 2001.

Definitions of industrial heritage and industrial archeology were finally fixed in *The Nizhny Tagil Charter for Industrial Heritage* (ICOMOS-TICCIH, 2003, p.1) after recognizing *The International Committee For The Conservation Of The Industrial Heritage* (TICCIH) as a consultant of the *International Council on Monuments and Sites* (ICOMOS):

*Industrial heritage consists of the remains of industrial culture which are of historical, technological, social, architectural or scientific value. These remains consist of buildings and machinery, workshops, mills and factories, mines and sites for processing and refining, warehouses and stores, places where energy is generated, transmitted and used, transport and all its infrastructure, as well as places used for social activities related to industry such as housing, religious worship or education. Industrial archaeology is an interdisciplinary method of studying all the evidence, material and immaterial, of documents, artefacts, stratigraphy and structures, human settlements and natural and urban landscapes [2], created for or by industrial processes.*

Later in 2011 the so-called “*The Dublin Principles*” as *Joint ICOMOS-TICCIH Principles for the Conservation of Industrial Heritage Sites, Structures, Areas and Landscapes* were published and acknowledged the importance of conservation and re-use and their relevance for a sustainable urban development (ICOMOS-TICCIH, 2011, p.1 and 2):

*Besides the tangible heritage associated with industrial technology and processes, engineering, architecture and town-planning, it includes many intangible dimensions embodied in*

*the skills, memories and social life of workers and their communities. [...] and [...] Yet, by extending the life-cycle of existing structures and their embodied energy, conservation of the built industrial heritage, can contribute to achieving the goals of sustainable development at the local, national and international levels. It touches the social as well as the physical and environmental aspects of development and should be acknowledged as such.*

This coincides with *The Paris Declaration. On heritage as a driver of development* (ICOMOS, 2011) formalizing and fostering the role of heritage in general and of cultural and built heritage in particular within the discussion on sustainable development. It also expressed the need of practical guidelines to implement projects (Douet, 2013) and to showcase successful conservation projects with the network of the *European Route of Industrial Heritage* (ERIH) founded in 2014 as the tourism information network of industrial heritage in Europe (ERIH, 2021). Main approach in Europe since then has been the re-use for cultural and touristic purposes which has also increased the appreciation of industrial sites and architecture within the population. This approach also reflects the socio-economic changes in Europe since the 1970s towards cleaner industries and digitisation, known as third and fourth industrial revolutions. While Central-Europe looks back to more than 40 years of experience in the transformation of industrial sites other parts of Europe and other continents have only started a decade or two ago to re-use their industrial sites (e.g. South-East and East Europe, Asia). In South-East and East Europe industries only broke down after the 1990s and Ifko & Stokin (2017) state in their preface „that changes affecting industrial heritage and its role in society require new responses and innovative solutions“. This also relates to the fact that in Eastern Europe large

industrial sites are often directly linked with workers' settlements as industrial planned cities which can be seen as as specific form of cultural heritage (Flierl, 2019). And, outside Europe this change usually happens under the pressure of growing populations and rapid urban growth, dealing directly with urgent housing issues in the city centers as expressed by (Frazier, 2019, p.73) related to the former textile mills in Mumbai and Shanghai:

*This discussion of the mill districts as sites of built heritage also suggests a more nuanced and contextualised understanding of the global process of gentrification and housing dis-possession.*

### Perception and Appreciation of Modern Industrial Heritage

Facing rapid globalisation, and triggered by new means of communication, transportation and digitisation have shaped the built environment of the 20th century worldwide. ICOMOS together with the Getty Conservation Institute (GCI) has presented *The Twentieth-Century Historic Thematic Framework* (Marsden & Spearritt, 2021) as a tool to identify those new typologies of buildings, sites and landscapes. Those new typologies also include industries and industrial sites which were not only characterized by more efficient mechanical and digital processes but also by corporate, functional and rational architecture—among them also the Zollverein Coal Mine Industrial Complex in Essen (Germany) built by the architects Schupp and Kremmer from 1928-31.

Being listed as UNESCO World Heritage site in 2001 as the first entirely modern industrial site it was complementing two other German industrial World Heritage Sites: the Völklingen Ironworks (Völklinger Hütte) and the Rammelsberg Visitor Mine (both listed in 1992) – in Rammelsberg the architects Schupp and Kremmer also designed the surface buildings in 1936. Only later two other modern industrial sites were inscribed as World Heritage in Germany: the Fagus Factory in Alfeld in 2011, and in 2015 the Speicherstadt and Kontorhaus District with Chilehaus in Hamburg. Another prominent example is the Van Nelle Factory in Rotterdam (The Netherlands), inscribed in 2014. Still industrial heritage—and in particular modern sites—is underrepresented among national and international monument listings, as well as are non-European sites in general.

As already mentioned before listed industrial heritage sites are most often developed for cultural and tourism purposes and the challenges of a suitable re-use and redevelopment are described in different studies (Quist & Stroux, 2016). The Van Nelle Factory has been redeveloped as a creative factory hosting design firms and offices as part of the creative industries. This can be seen as an exemplary approach to guarantee the future of modern industrial heritage, as also formulated by Chilingaryan (2014, p. 172):

*The qualitative evolution of industrial heritage gradually affected the perception of industrial aesthetic, modifying it and establishing a new image that is linked with the contemporary culture, post-industrial lifestyles and the idea of a creative environment. New forms of work and leisure, the centrality of consumption culture in the socio-cultural structure of the post-industrial societies—these are all crucial factors that affect the ways that (industrial) heritage is being managed today.*

While many modern storage and factory buildings offer suitable, large and flexible spaces to be redesigned with spatial quality and adapted to contemporary needs, other modern industrial heritage typologies are contested and intensively debated. ICOMOS Germany has published the discussion on nuclear power plants as industrial heritage (Brandt & Dame, 2019, 9) and concludes:

*While in 1997 the first German research reactor, the 'Atomic Egg' in Garching, was placed under protection as a monument, an investigation and discussion regarding the possible preservation of a large-scale industrial nuclear power plant are still pending in Germany today.*

In the same publication Bastgen (2019, 68) reflected on the perception and societal value of the preservation of such contested sites and identified possible positive aspects in it:

*Only the identification as nuclear power plant can trigger the variety of associations and emotions related to the controversy in each viewer, therefore construction is of special meaning. A nuclear power plant could function as intended monument for the movement and as a memorial for underground nuclear waste at the same time.*

These current discussions reveal the complexity of perception, appreciation and conservation of modern industrial buildings and sites which at the same time bear huge potentials for as sustainable preservation and redevelopment. Edensor (2005, 172, 51) envisions industrial ruins as “a host of alternative forms of public space”, “helping to confound the binaries between urban-human and rural-‘natural’”.

These aspects were all reflected in the introductory session in which students were grouped according to the thematic focus of their individual abstracts from the pre-semester. They were asked to identify and discuss the main themes and concerns addressed in their abstracts which dealt with different buildings, sites or heritage aspects. Each group should agree on five to seven keywords to describe these main themes and concerns and that are seen as relevant for the future documentation, conservation and re-use. The main themes and concerns could be clustered as follows:

- embedded energy, sustainable materials and energy efficiency, cradle to cradle, CO2,
- redevelopment and sustainable renovation, biodiversity and landscape,
- aesthetics, building analysis, H-BIM,
- forgotten heritage, learning from heritage,
- open source repository, data accessibility,
- digital display, 3D-model interactive,
- preservation through AR and VR,
- commemorating, community engagement.

In a next step the themes were further narrowed down and specified to be elaborated and prepared for dissemination by the students using digital tools and technologies. Tools and technologies identified by the students were: websites, apps, short movies, films, as well as applications of 360-degree images, augmented and virtual reality and online platforms to display their exhibits in a virtual exhibition. In this catalogue the exhibits are presented in two thematic blocks:

- re-use, biodiversity, embodied and renewable energy and
- documentation, visualisation, digitisation and gamification.

Students in the first block aimed to raise public awareness on sustainable aspects of re-used industrial sites based on their research findings: e.g. clarifying typologies and re-use (Industrial Heritage Quartett), the embodied energy and re-use potential of certain Zollverein buildings (Fig. 2) or the sustainable refurbishment of the Sanaa-Cube, finally the biodiversity at the Zollverein site and a documentation of the first solar plant in Egypt.

Students of the second block were analyzing the mechanical mechanisms (Fig. 3) originally used industrial buildings and aesthetics of industrial architecture, here the Fagus Factory and Zollverein Shaft XII. Another group was focusing on the digital reproduction of industrial heritage sites through photo-



Figure 3

grammetry in an open source repository, and the visualization of industrial heritage sites in games to raise awareness and disseminate knowledge about the Zollverein and the Mumbai Mills (India).

#### Outlook

The exhibits highlight the potential of creative and innovative ways of visualisation and dissemination that can help to increase the visibility of academic research and of the potential of industrial remains to larger professional audiences, lay people and society. At the same time the ConCom course has raised the awareness of the students about the current discussions, policies and tools used in the heritage context and discourse. It will enable them to take part in the ongoing European dialogue

on cultural heritage and built environment (Veldpaus, Fava, Brodowicz et al., 2019).

#### Acknowledgements

We like to thank our students for their commitment to pick up the challenge to explore content and technologies and to create inspiring results, namely: Ahmad Elnossery, André Popp, Andres Buitrago, Anissa Sofia Krain, Ardalan Mirhadinejad-fard, Ashley Grover, Basim Al-Mousa, Benedict Neise, Buket Yoleri, Cem Ünal, Charnele Lukman, Fadi Khamam, Frauke Fischer, Gizem Demirhan, Godo Zibur Singh, Hyeonji Seol, Irina Miroschnitschenko, Jessica Moldenhauer, Junaid Nasir, Ken Tietjen, Lena Beckervordersandforth, Leon Kenschake, Leon Landwehr, Mahan Mashayekh, Mahmoud Abdelghany, Maximilian

Kirchhoff, Nizar Fanari, Paul Heistermann, Prajith Gorentla, Puree Srisuk, Regina Klippenstein, Rutvi Varia, Sahar Heidari, Soumia El Mourabit, Shashi Karmaker, Tina Safarhamidi, Viona Marx, Vitalij Göttmann.

Dora Chatzi-Rodopolou (University of the Aegean) has contributed with her research experiences related to adaptation of industrial heritage in Europe and by giving feedback to the students.

Kurt C. Reinhard (Memofaktur) has helped with his knowledge about Zollverein coalmine and to get access to archives and material related and by giving individual feedback to the students.

Our special thanks go to Stefan Römer (Zollverein Foundation) who has welcomed the students on site and paved the way to within the organisation.

#### References

Bastgen, M. M. (2019). Uncomfortable Legacy. The Monument Value of Nuclear Power Plants. Brandt, S. & Dame, T. (eds.) *Nuclear Power Stations Heritage Values and Preservation Perspectives*. 58-68.

Brandt, S., Dame, T. (2019). *Nuclear Power Stations Heritage Values and Preservation Perspectives*. ICOMOS - Hefte des Deutschen Nationalkomitees LXVIII. ICOMOS, Nationalkomitee der Bundesrepublik Deutschland. [https://www.icomos.de/icomos/pdf/kkw\\_inhalt\\_.pdf](https://www.icomos.de/icomos/pdf/kkw_inhalt_.pdf). Retrieved 23 April 2022

Chilingaryan, N. (2014). *INDUSTRIAL HERITAGE: IN-BETWEEN MEMORY AND TRANSFORMATION. Exploratory Research into Transformation Processes of Former Industrial Complexes of Leipziger Baumwollspinnerei (Leipzig) and Mattatoio di Testaccio (Rome); New Meanings of Industrial Heritage*. Dissertation. Bauhaus-Universität Weimar, Faculty of Architecture and Urbanistik. [https://e-pub.uni-weimar.de/opus4/frontdoor/deliver/index/docId/2229/file/Doctoral+Thesis\\_Naira+Chilingaryan\\_16.05.14\\_druck\\_pdfa.pdf](https://e-pub.uni-weimar.de/opus4/frontdoor/deliver/index/docId/2229/file/Doctoral+Thesis_Naira+Chilingaryan_16.05.14_druck_pdfa.pdf). Retrieved 23 April 2022.

Chatzi Rodopolou T. (2020). *Control Shift. European Industrial Heritage Reuse in Review*. Dissertation. A+BE | Architecture and the Built Environment, n. 13, p. 1-630, ISSN 2214-7233. <https://journals.open.tudelft.nl/abe/article/view/5195> Retrieved 4 April 2022.

Douet, J. (ed.) (2013): *Industrial Heritage Re-tooled: The TICCIH guide to Industrial Heritage Conservation*. Routledge, New York.

DOCOMOMO International (2021). *DOCOMOMO Constitution. Revision 2010*. [https://docomomo.com/wp-content/uploads/2020/01/104836\\_docomomoconstitution.pdf](https://docomomo.com/wp-content/uploads/2020/01/104836_docomomoconstitution.pdf) Retrieved 21 April 2022.

Edensor, T. (2005). *Industrial Ruins: Spaces, Aesthetics, and Materiality*. New York: Berg. [https://www.brown.edu/Departments/Joukowsky\\_Institute/courses/archaeologicaltheory/files/3733144.pdf](https://www.brown.edu/Departments/Joukowsky_Institute/courses/archaeologicaltheory/files/3733144.pdf). Retrieved 23 April 2022.

ERIH (2021). *European Industrial Heritage: The International Story*. 3rd edition 2021. ERIH – European Route of Industrial Heritage e.V., Meerbusch. [https://www.erih.net/fileadmin/Mediendatenbank/ERIH\\_BROCHURES/ERIH\\_Brochure\\_European\\_Industrial\\_Heritage\\_06.2021.pdf](https://www.erih.net/fileadmin/Mediendatenbank/ERIH_BROCHURES/ERIH_Brochure_European_Industrial_Heritage_06.2021.pdf). Retrieved 23 April 2022.

Flierl T. (2019). Stahlstädte – Stalinstädte. Neue Industriestädte in Osteuropa. *Rethinking Modernity. Architecture and Urban Planning of the 20th Century – Between Avant-garde and Tradition*. 54-58. [https://www.icomos.de/icomos/pdf/icomosmoderne-neu-denken\\_web\\_5nov2019.pdf](https://www.icomos.de/icomos/pdf/icomosmoderne-neu-denken_web_5nov2019.pdf). Retrieved 23 April 2022.

Frazier, M.W. (2019). The Political Heritage of Textile Districts: Shanghai and Mumbai. *Built Heritage* 3, 62–75. <https://doi.org/10.1186/BF03545744>. Retrieved 23 April 2022.

ICOMOS (2011). *The Paris Declaration. On heritage as a driver of development*. Adopted at Paris, UNESCO headquarters, on Thursday 1st December 2011. [https://www.icomos.org/Paris2011/GA2011\\_Declaration\\_de\\_Paris\\_EN\\_20120109.pdf](https://www.icomos.org/Paris2011/GA2011_Declaration_de_Paris_EN_20120109.pdf). Retrieved 23 April 2022.

ICOMOS Germany (2019). *Rethinking Modernity. Architecture and Urban Planning of the 20th Century – Between Avant-garde and Tradition*. ICOMOS - Hefte des Deutschen Nationalkomitees LXIX. [https://www.icomos.de/icomos/pdf/icomosmoderne-neu-denken\\_web\\_5nov2019.pdf](https://www.icomos.de/icomos/pdf/icomosmoderne-neu-denken_web_5nov2019.pdf). Retrieved 23 April 2022.

ICOMOS-TICCIH (2003). *The Nizhny Tagil Charter for the Industrial Heritage*. July 2003. <https://www.icomos.org/18thapril/2006/nizhny-tagil-charter-e.pdf> Retrieved 23 April 2022.

ICOMOS-TICCIH (2011). *Joint ICOMOS-TICCIH Principles for the Conservation of Industrial Heritage Sites, Structures, Areas and Landscapes*. "The Dublin Principles". Adopted by the 17th ICOMOS General Assembly on 28 November 2011. [https://www.icomos.org/Paris2011/GA2011\\_ICOMOS\\_TICCIH\\_joint\\_principles\\_EN\\_FR\\_final\\_20120110.pdf](https://www.icomos.org/Paris2011/GA2011_ICOMOS_TICCIH_joint_principles_EN_FR_final_20120110.pdf). Retrieved 23 April 2022.

Ifko, S., Stokin, M. (eds.) (2017). *Monographic Publications of ICOMOS Slovenia I 02. Protection and Reuse of Industrial Heritage: Dilemmas, Problems, Examples*. ICOMOS Slovenija. <https://plus.si.cobiss.net/opac7/bib/293115904>. Retrieved 22 April 2022.

Pottgiesser, U., Dragutinovic, A., Loddo, M. (eds.) (2021). *MoMove Modern Movement and Infrastructure*. Technische Hochschule Ostwestfalen-Lippe, Detmold. <https://doi.org/10.25644/3m9j-0f94>. Retrieved 23 April 2022.

Quist, W.J., Stroux, S. (2016). Design with History: The Re-development of the Industrial Area Oostenburg. Tostoes, A. & Ferreira, Z. (eds.). *Proceedings of the 14th International Docomomo Conference: Adaptive Reuse. The Modern Movement towards the Future*, 289-296.

Marsden, S., Spearritt, P. (2021). *The Twentieth-Century Historic Thematic Framework: A Tool for Assessing Heritage Places*. With contributions from Leo Schmidt, Sheridan Burke, Gail Ostergren, Jeff Cody, and Chandler McCoy. Los Angeles: Getty Conservation Institute. [https://hdl.handle.net/10020/gci\\_pubs\\_historic\\_thematic\\_framework\\_tool](https://hdl.handle.net/10020/gci_pubs_historic_thematic_framework_tool). Retrieved 23 April 2022.

Veldpaus, L., Fava, F., Brodowicz, D. et al. (2019). *Mapping of current heritage re-use policies and regulations in Europe. Complex policy overview of adaptive heritage re-use*. OpenHeritage: Deliverable 1.2 (Report). December 2019. [https://openheritage.eu/wp-content/uploads/2020/01/D1.2\\_Mapping\\_current\\_policies\\_regulations.pdf](https://openheritage.eu/wp-content/uploads/2020/01/D1.2_Mapping_current_policies_regulations.pdf). Retrieved 23 April 2022.

# THE INDUSTRIAL HERITAGE QUARTET

ANISSA SOFIA KRAIN, VIONA MARX, IRINA MIROSCHNITSCHENKO  
& BUKET YOLERI



## Idea

Germany has a significant amount of industrial buildings and sites. They represent an important legacy of previous time and can not be omitted from history. The industrial buildings are diverse in their use and architectural style. Often these industrial buildings are located in the immediate vicinity and are usually not noticed enough, although many of the buildings are worth seeing because of their architecture and history. Many of the buildings and sites can offer recreational activities through their conversion into museums, event spaces or similar. In order to get a good overview of these many industrial buildings and sites, the idea of this project is to create a website and a complementary industrial heritage quartet.

## Methods and Tools

The website structures industrial buildings and sites into 6 categories: Production and Processing, Textile, Mining, Transportation, Converted and Visions. In the first four categories, these themes reflect the original use of the buildings, the category „Converted“ takes up what we consider to be particularly successful examples of conversion, and the visions show vacant, old industrial buildings with a concrete proposal for future conversion on our part. The Quartett cards provide the most important data of the individual industrial buildings and sites in a very abbreviated form, and further enable the playful transfer of knowledge. Photos underline and complement the information, so that one can establish a link between the appearance and the history. For more detailed information about the history, current use and architecture, these can be accessed in the form of texts on the website. The locations of each building can also be viewed there via a map. The quartet can be viewed digitally as well as played in printed form.

## Outlook

With the help of the website and the quartet, people should get more knowledge about their surroundings, broaden their horizons regarding industrial heritage and gain places to visit. The history of industrial buildings and their production should not be forgotten and thus prevent the risk of vacancy. The reuse of such buildings is a very important issue with regard to the appreciation of the existing buildings and shows that even if the buildings and sites are no longer needed for their original use, it is not a reason for demolition.



Online  
<https://thowlindustrialqua.wixsite.com/my-site>

**Figure 1:**  
- Zeche Zollverein -  
by Anissa Sofia Krain  
**Figure 2:**  
- Zeche Zollverein -  
by Anissa Sofia Krain  
**Figure 3:**  
-UNESCO Welterbe Fagus Werk  
Frontansicht by <https://www.fagus-werk.com/de/media/>  
**Figure 4:**  
-Nordwolle Delmenhorst by Stadt  
Delmenhorst  
**Figure 5:**  
-Ringlokschuppen by Sarah Jonek  
**Figure 6:**  
-Speicher XI by Anissa Sofia Krain  
**Figure 7:**  
-Quartet cards „Vision“  
**Figure 8:**  
- UNESCO Welterbe Fagus Werk  
Frontansicht -  
by <https://www.fagus-werk.com/de/media/>

Figure 1



# THE INDUSTRIAL HERITAGE QUARTET



Figure 2

mining industry

Learn more about the mining industry.



Figure 3

production and processing

Learn more about the production and processing industry.



Figure 4

textile industry

Learn more about the textile industry.



Figure 5

transport industry

Learn more about the transport industry.



Figure 6

reused buildings

Learn more about the reused buildings.



visions

Learn more about visions for fallow building.



©UNESCO-Welterbe Fagus-Werk

Figure 8

Zeche Ibbenbüren

Location	Ibbenbüren
Construction year	16th Century
Architect/founder	Unknown
Former use	Coal mine
Vision	Scientific creativity campus
Style	Renaissance
Status	Deconstructed, vacant

6 A

Zeche Niederberg

Location	Neukirchen-Vluyn
Construction year	1911
Architect/founder	Niederheinische Bergwerks AG
Former use	Mine
Vision	Students dormitory
Style	Modern
Status	Vacant

6 D

Kokerei Hansa

Location	Dortmund
Construction year	1928
Architect/founder	Hellmuth von Stegmann und Stein
Former use	Cokery
Vision	Residential Park
Style	Modern
Status	Place to visit

6 D

Figure 7

# ADAPTIVE REUSE OF A WORLD HERITAGE SITE

SOUMIA EL MOURABIT, SHASHI KARMAKER & RUTVI VARIA



Figure 1

## Idea

Zollverein is one of the most renowned UNESCO world Heritage site situated in Essen in Germany. The site foundation go as back as in 1840 and many zollverein cokerie buildings have been renovated since year 2010<sup>[1]</sup>. In the west most section of the plant is a building called screening plant which is yet to undergo the redesign and rehabilitation, making it the subject of our interest. A detailed analysis has been carried out by the team to assess Value and Damage caused to the current status quo of the building considering multiple factors<sup>[2]</sup>. Interventions have been proposed for the same by taking into account the two extreme rehabilitation scenarios being : 1) Office Buildig 2) Event Space.

## Methods and Tools

The process and method involved while considering rehabilitation for the screening plant, was defining a Significance Assessment so as to cover all the significant aspects<sup>[3]</sup>. The two prominent aspects were value assessment and damage assessment in accordance to consideration of two different extreme scenarios for redesign.

The main focus was the typology of the windows on the facade of the Screening plant and factors affecting the Exterior architecture like symmetry in the window axes<sup>[4]</sup>.With the help of the provided data, the physical attributes mentioned, of the envelope are examined in accordance to parameters like their heritage significance, newness value possible causes for the damage over the period of its inactive years.Simultaneously few cases for the buildings rehabilitated from the coal plant itself was taken into consideration as references.

Through extensive research and from the materials available, few possible interventions are proposed, on the basis of the type of reuse, the rehabilitated building might have. Along with window interventions, equipments and internal space has also been considered as a factor so as to support the theoretical possible proposal on the grounds of usage of the Screening plant.

## Outlook

The two scenarios, namely – 1) The office building and 2) the Event location were considered for the assessments and interventions. Multiple factors like thermal quality, humidity, heritage value, etc were taken into consideration to narrow down the hypothesis that the design is based on the function and reuse of the building, which it will be rehabilitated into.

**Figure 1:**  
Zeche Zollverein  
Image provided by Stiftung Zollverein

**Figure 2:**  
Value Assessment of the Window  
Image provided by Stiftung Zollverein

**Figure 3:**  
Damage Assessment of the Window  
Image provided by Stiftung Zollverein

**Figure 4:**  
Value and Damage Assessment for  
Equipment  
Image provided by Stiftung Zollverein

**Figure 5:**  
Axonometric View of Interventions  
Made by team members

## References

[1]<https://www.zollverein.de/app/uploads/2018/02/UNESCO-Welterbe-Zollverein-Imagebrosch%C3%BCre-englisch.pdf>

[2] Annebel Formsma, Ewa Ziemiecka, Huub Fenten, Kunzhao Zou, Nienke Smit, Yu Anna Buijnick, Zilin Zhou. Analysis of glazing and indoor climate of the ketelhuis, leiden Ar0141

[3] Angel Ayón, Uta Pottgiesser, Nathaniel Richards. Reglazing Modernism - Intervention strategies for 20th-century icons.2019

[4] Margo Smeenge, Pratika Chankar, Diletta Wesel, Julia Schutten, Joske Oetelmans, Alexandra Diephuis, Jennifer Lips. Meelfabriek – leiden Glazing & interior climate Analysis report



Online

<https://vimeo.com/672045908>

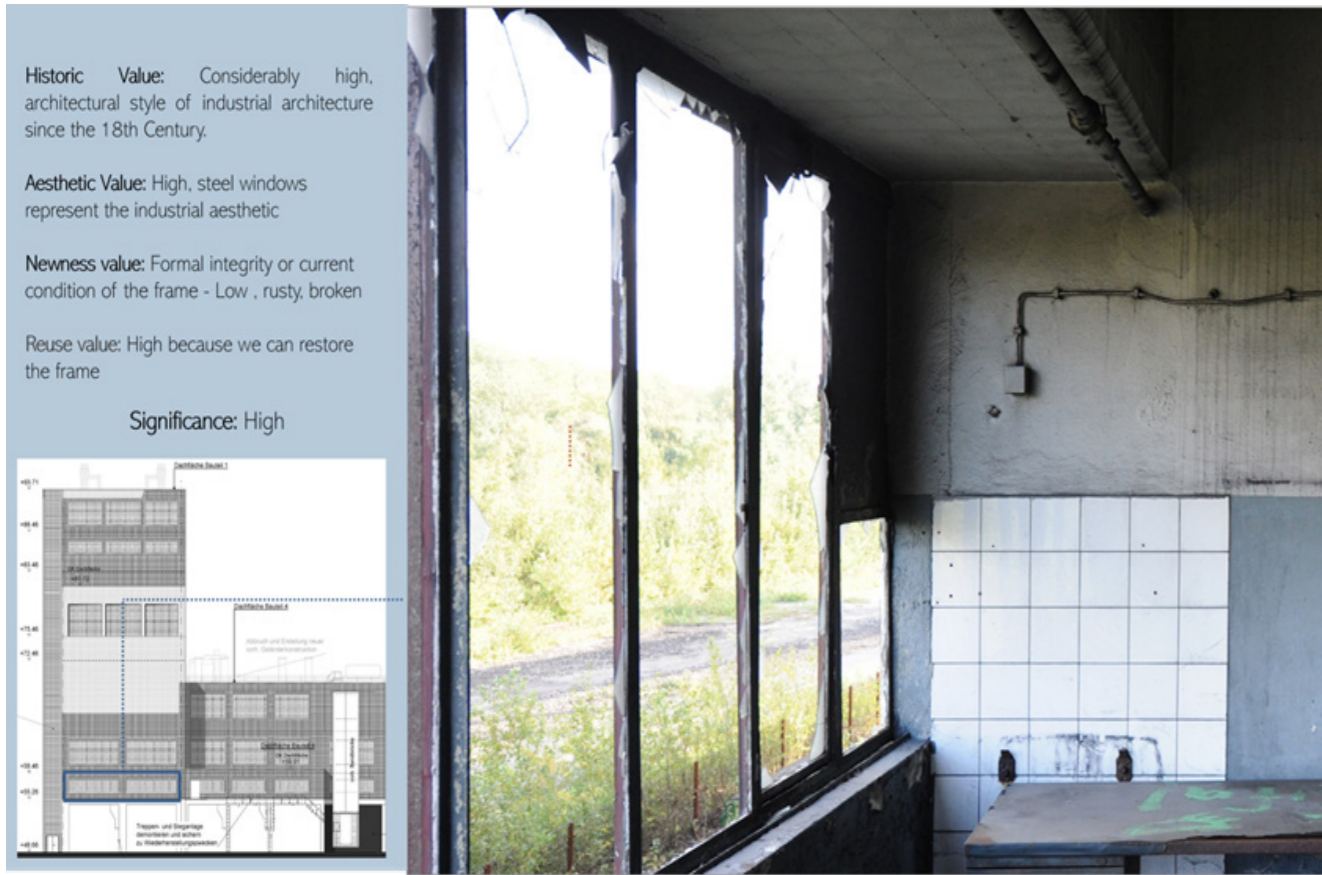

Figure 2



Figure 4



Figure 3

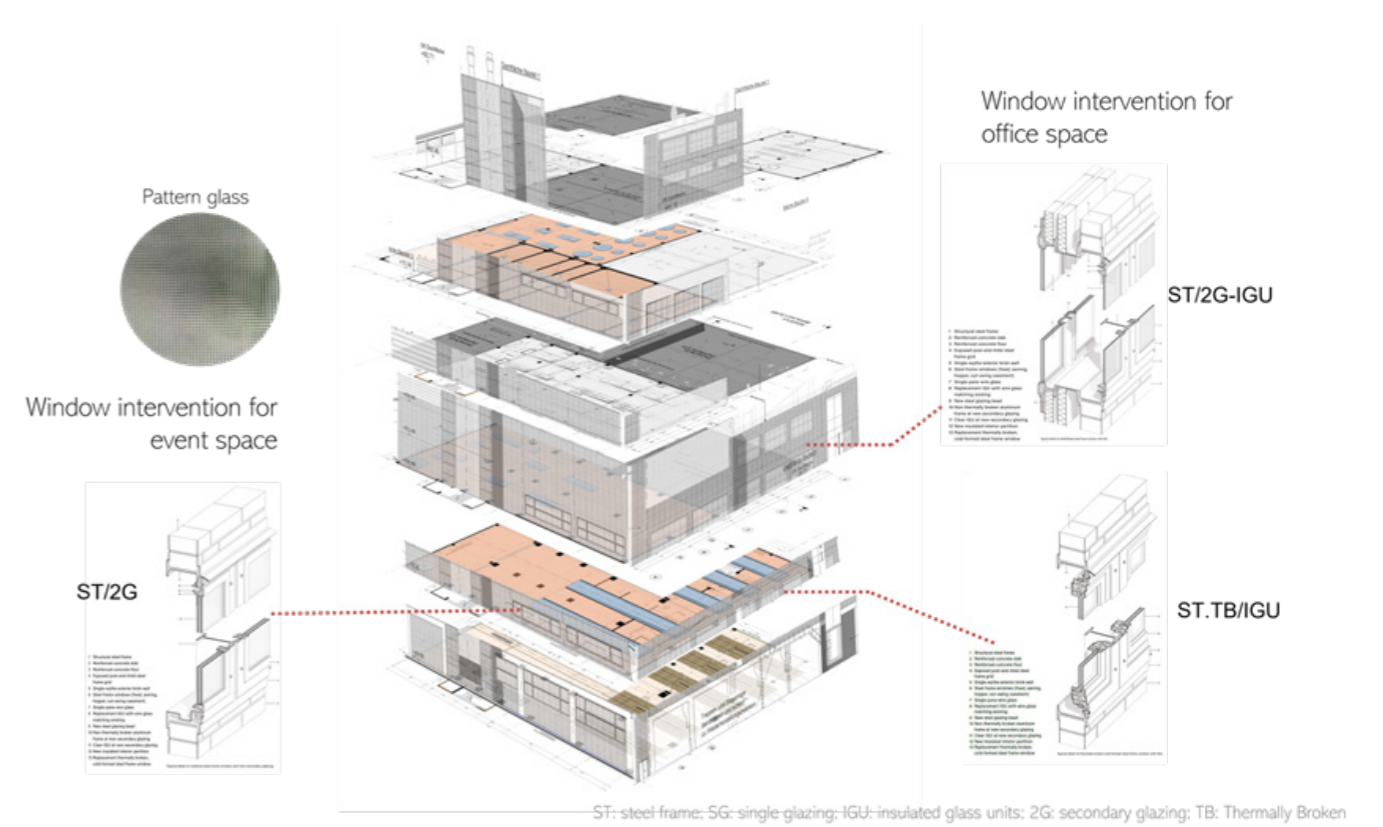

Figure 5

# SUSTAINABLE REFURBISHMENT OF ZOLLVEREIN SCHOOL OF MANAGEMENT, ESSEN, GERMANY

CEM ÜNAL & PRAJITH GORENTLA



Figure 1

## Idea

The main idea of this project was to define a sustainable model for potential replacement of the Active Thermal Insulation technology in Zollverein School of Management building, once the refurbishment is needed. Considering the building's eminence and the UNESCO certification as a heritage building, the suggested refurbishment at the same time preserves the aesthetics and originality of the building. [1]

## Methods and Tools

The first step of the research process was to study the Active Thermal Insulation and its installation in this building. The second step was identifying the location coordinates and climate analysis of the building by using Ladybug (Rhino plugin). We have found that the direction of wind towards the building was from south and south-west direction along with direct and diffusive radiation. Considering these parameters and findings, we made the refurbishment proposal integrating transparent PV panels. The panel can generate energy and contribute to the energy efficiency of the building. The additional contribution of the project was search for alternative materials which could substitute the PV panels. Clay was recognized as a possible insulation material due to its thermal coefficient values. However, it did not fulfil the air tight sealing for the cold or heat to be transmitted inside. In parallel with further materials search, we calculated U values using Flixo software with existing wall details and with multiple combinations until we achieved a NO cold bridge construction. [2]

We have made calculations with different combinations such as fenestration being replaced with highly insulated aluminum frames and triple glazing along with clay, rock wool and sheep wool. Lastly, aluminum fenestrations with highly insulated frames and a TGU with a layer of sheep wool and clay mould as cladding material proved that there is no formation of cold bridges at the corner and performs well as heating and cooling device.

## Outlook

Making the cube Green again was our main motivational statement when we started the project and we have made sure that we carry our theme in every process we followed and implementations we made to our digital presentation i.e., our website. We retained the existing values and originality of building yet made it more Green in terms of sustainability with the proposal of substitutes which could perform as good as the Active Thermal Insulation technology in the building.



Online:  
[www.thesustainablecube.com](http://www.thesustainablecube.com)

**Figure 1:**  
Betong huset Essen - panoramio (2)  
- Commons.Wikimedia

**Figure 2:**  
Illustration of Active Thermal Insulation- SketchUp

**Figure 3:**  
Refurbished wall detail – SketchUp

**Figure 4:**  
Schematic diagram of Active Thermal Insulation – AutoCAD

**Figure 5:**  
Existing wall construction with materials - Flixo

**Figure 6:**  
Refurbished wall construction with materials - Flixo

**Figure 7:**  
U value calculation of existing wall - Flixo

**Figure 8:**  
U value calculation of refurbished wall – Flixo

**Figure 9:**  
Temperature map of existing wall - Flixo

**Figure 10:**  
Temperature map of Refurbished wall - Flixo

## References

[1] Zollverein School Building: Active Thermal Insulation [Online]. Zigner|SneadArchitects,2008[Viewed:24-12-2021].<https://www.zigersnead.com/current/blog/post/zollverein-school-building-active-thermal-insulation/>

[2] Engineering Toolbox, (2003). Solids, Liquids and Gases - Thermal Conductivities. Available from:[https://www.engineeringtoolbox.com/thermal-conductivity-d\\_429.html](https://www.engineeringtoolbox.com/thermal-conductivity-d_429.html)

[3] pilles, les. (2006). Betong huset Essen. photograph, Essen.

[4] Blog Post 2: Building and Energy Flows [Online]. enf7xg, 2014[Viewed: 04.01.2022] <https://ethanfildmanarch.wordpress.com/2014/09/25/blog-post-2-building-and-energy-flows/>

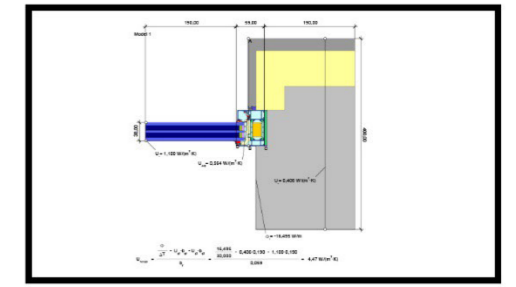
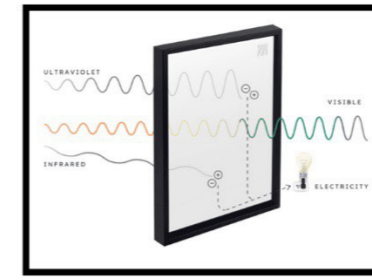
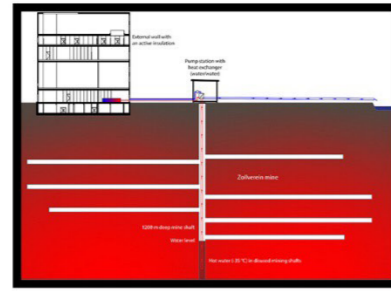
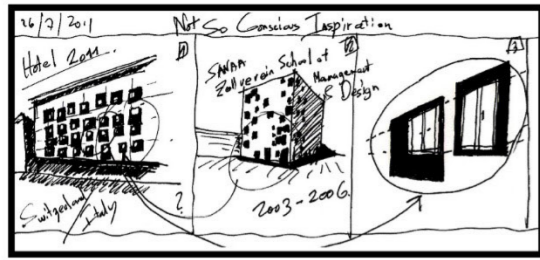

History



Active Thermal Insulation



Architectural Detail

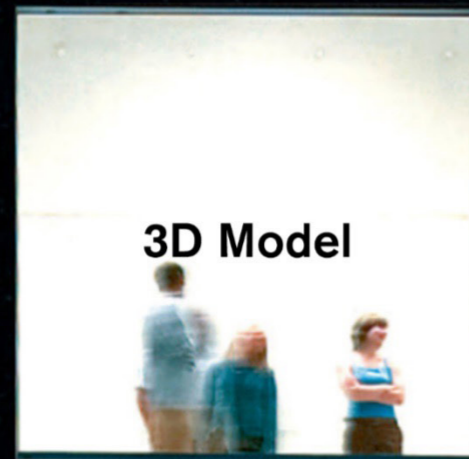

3D Model

NOW FUTURE

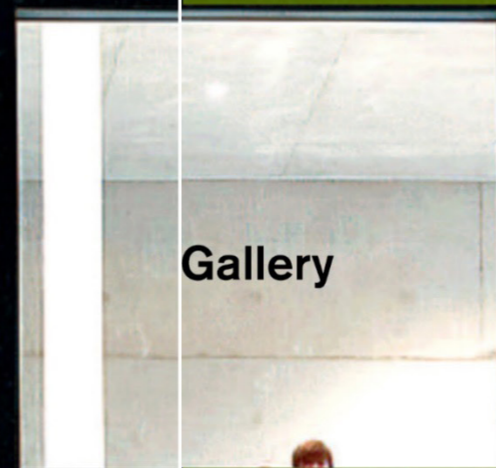

Gallery

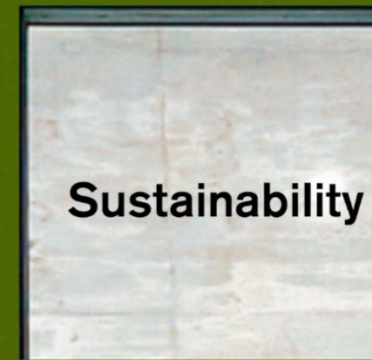

Sustainability



Technical Documents

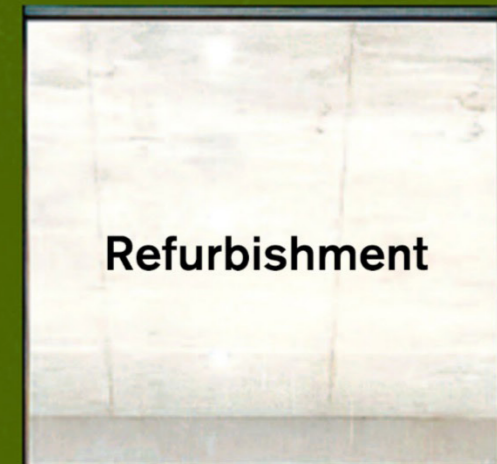

Refurbishment

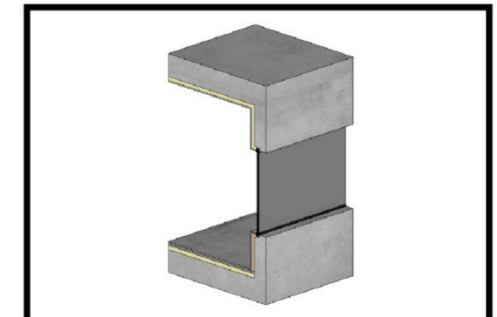
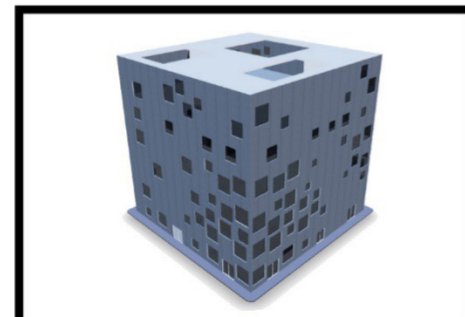
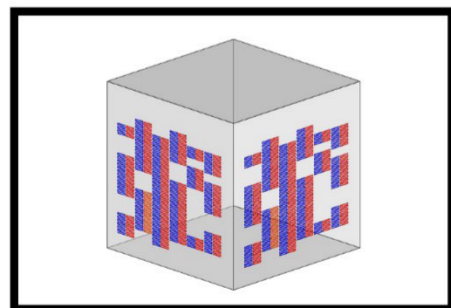

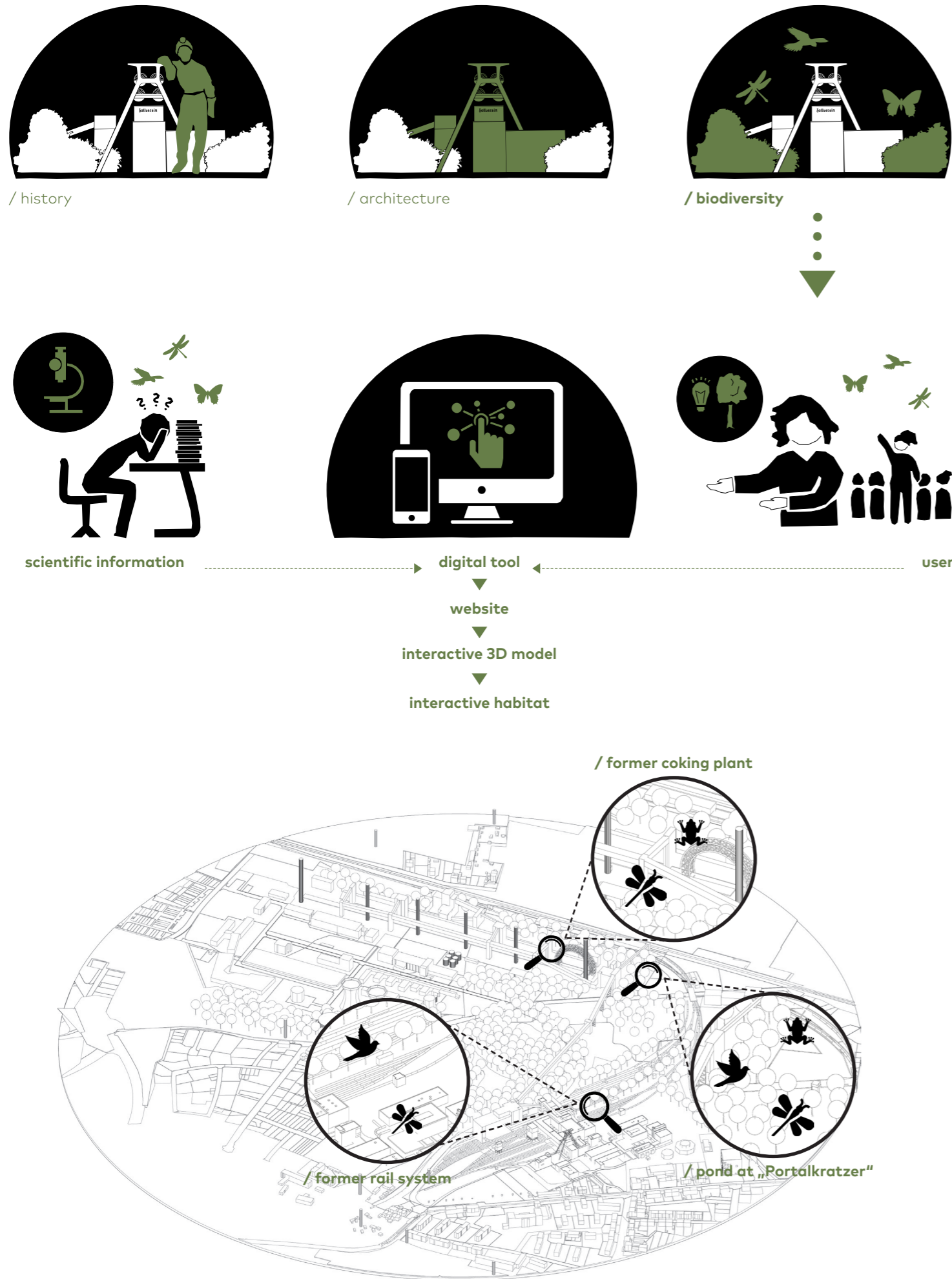

# BIODIVERSITY AT ZOLLVEREIN

KEN TIETJEN, NIZAR FANARI, PAUL HEISTERMANN & FADI KHAMAM

## Idea

The Zeche Zollverein is known as a UNESCO cultural heritage for its social importance and its famous industrial architecture. In the past decades, a new phenomenon has deployed on the industrial wasteland. Over a longer period of time, nature was able to reclaim a part of the industrial site. Many rare and endangered animal and plant species have therefore found a new home at Zollverein.

This ecological diversity aspect has been only documented in a scientific way and not for normal people. The aim of this project is to explain the valuable information and ecological connections at the Zollverein in a simplified way so it can reach as many people as possible.

## Methods and Tools

The platform for this digital tool is a website that hosts an interactive 3D model. The model had to be created from scratch. In a complex process, the raw data of the online portal of the district government of Cologne was imported, filtered, and then converted into 3D elements.

Through the interactive popups, it is possible to get from the 3D model into the respective in-depth areas. Real images of the selected habitats at Zollverein were animated and substantiated with natural sounds of the immersion areas. The researched scientific information is transported by graphical control elements that can be activated with a mouse over effect.

## Outlook

The scope of the tool so far includes a 3D model, as well as three in-depth areas. This covers only a fraction of the ecological diversity at Zollverein. In the next steps, new areas could be added and discovered. It is also possible that other industrial wastelands could be processed accordingly, thus creating a comprehensive digital catalog of the biodiversity on Germany's industrial wastelands. The tool could be an important component for better understanding and spreading awareness of the biodiversity that's surrounding us.



Online  
<http://industrienatur-zollverein.com/>

**Figure 1:** Idea and Concept  
**Figure 2:** 3D-Model  
**Figure 3:** Tools and Methods  
**Figure 4:** Habitat former rail system  
**Figure 5:** Habitat former coking plant  
**Figure 6:** Habitat pond at „Portalkratzer“

## References

[1] Peter Keil & Ester Guderley. 2017. Artenvielfalt der Industrienatur - Flora, Fauna und Pilze auf Zollverein in Essen

[2] Goertzen, D., (2008). Industriebrachen im Ruhrgebiet – Lebensraum für Libellen?. Libellula 27 (3/4), 163-184.

[3] Heinrich Theodor Grütter & Ester Guderley. 2017. Industrienatur auf Zollverein

[4] Keil, P., (2007). Auf lebendigen Brachen unter extremen Bedingungen – Industrietytische Flora und Vegetation des Ruhrgebietes. PdN-BioS 2/56. Jg.2007, 20-26.

[5] Marth, H., (2018). Zollverein - Welterbe und Zukunftswerkstatt.

Figure 1

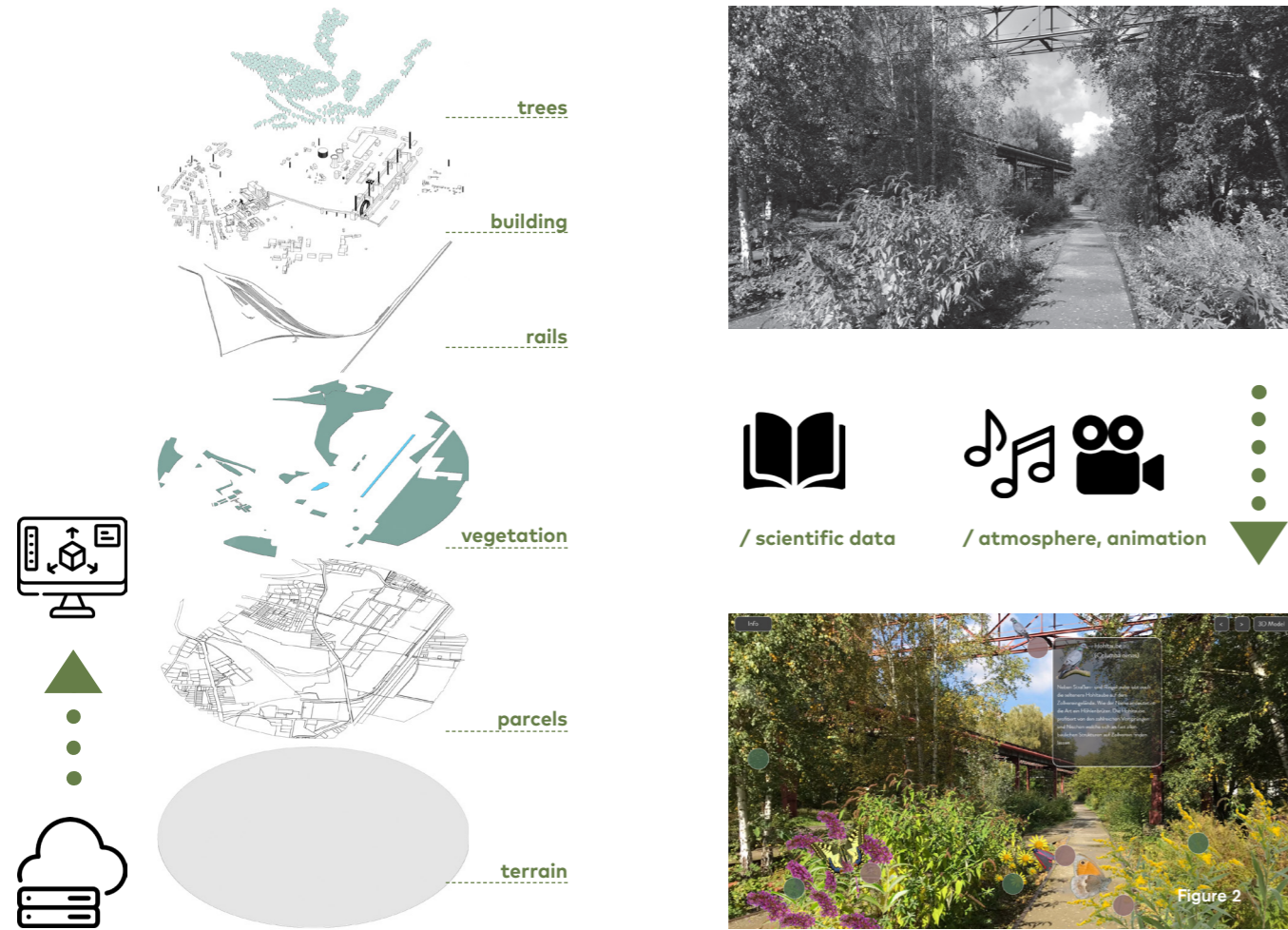

Figure 2

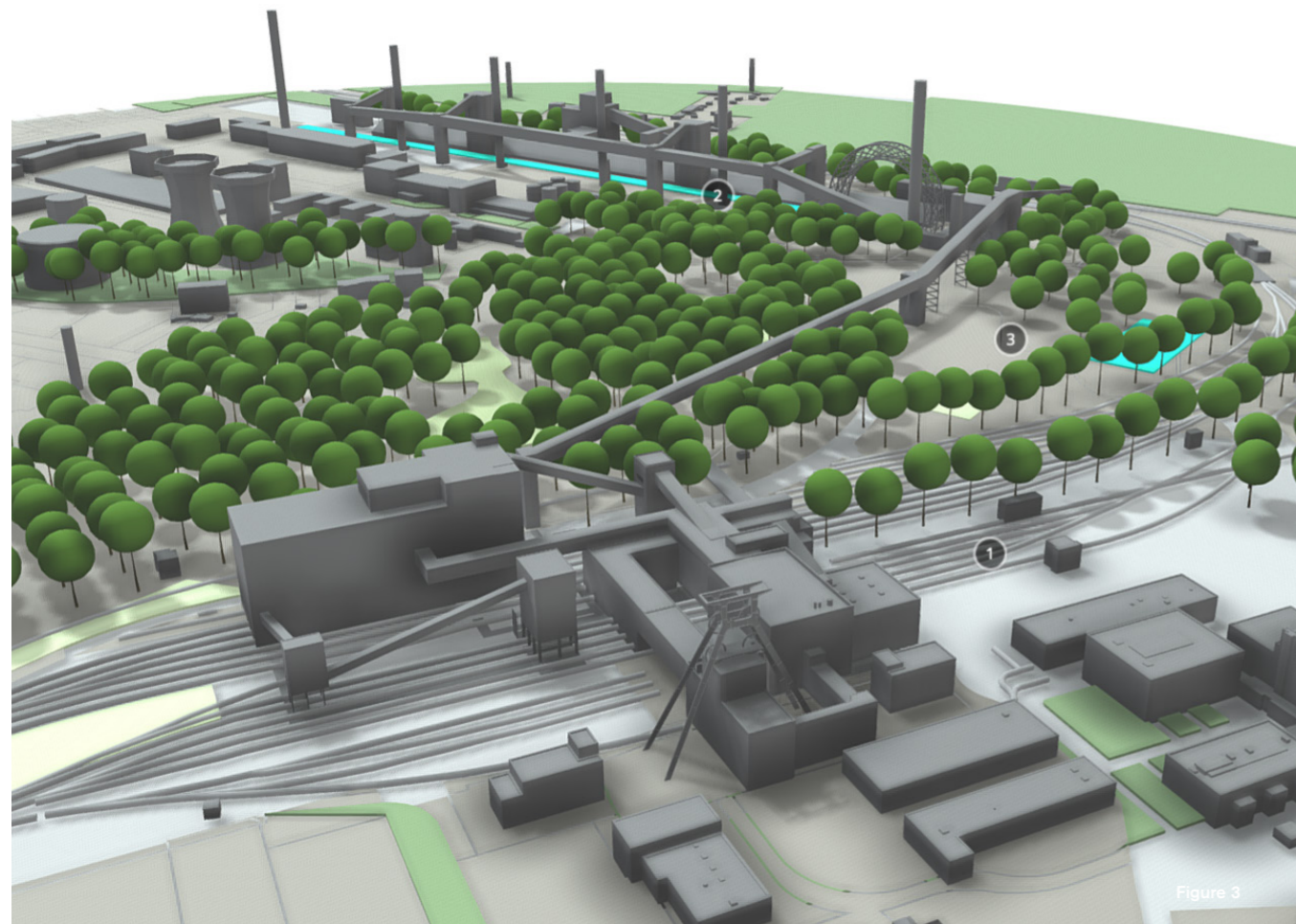

Figure 3



Figure 4



Figure 5



Figure 6

# ZOLLVEREIN EMBODIED ENERGY: SALT FACTORY CASE STUDY

ARDALAN MIRHADINEJADFARD, HYEONJI SEOL,  
SAHAR HEIDARI & TINA SAFARHAMIDI



Figure 1

## Idea

The conversion of the salt factory on the coking plant of the UNESCO World Heritage Site Zollverein into the new display depot of the Ruhr Museum was funded as part of the „National Urban Development Projects“ program. The salt factory was built in 1959 as a production and processing facility as part of the coking plant complex planned by Fritz Schupp. In 1993 the salt factory was finally shut down. In 2017, the Darmstadt architectural office Planinghaus undertook the conversion of the building on behalf of the Zollverein Foundation. [1]

The main priority of this conversion project was to showcase the architecture heritage itself by preserving it as much as possible. However, this project is of great value not only in a cultural aspect but also in an environmental aspect. The value is that we can cut down a significant amount of carbon emissions that cause climate change by reusing the building. Whereas significant efforts have been made to reduce the amount of carbon emissions during the building use period, carbon emissions while extracting, processing, and transporting materials, which is called embodied energy, for building construction have been overlooked.

## Methods and Tools

Firstly, we built 3d BIM models of the Salt Factory in Revit based on architectural plans collected from architects from Planinghaus and Suedstudio who undertook the project. Furthermore, we calculated embodied energy of the model with One Click LCA, which can be plugged in Revit. Using those software tools, we could examine the building in detail, quantify all the materials in the building, and apply LCA data already loaded in the plug-in tool. Consequently, we converted the building models into carbon emissions based on information included in the building model and LCA data loaded by the plug-in from current LCA databases.

To inform our study, we made a website. We exhibited the result of calculations with bubble diagrams that show which material contributes the most to carbon emissions. Also, we exhibited photos before/after the project and a 3d model of the building.

## Outlook

The work documented in this project demonstrates an approach for implementing a building's life cycle assessment (LCA) on building renovation projects, suggests an approach for conducting a comparison between renovation and new construction. Renovating buildings is an appropriate alternative instead of demolition and also replacement of building parts and elements extends the building's life and avoids demolition waste, encourages reuses of the embodied energy.



Online  
<https://seolhyeonji93.wixsite.com/team7c5th-owl>

**Figure 1:**  
Refurbished Salt factory (Open Depot),  
[www.ruhrmuseum.de](http://www.ruhrmuseum.de)

**Figure 2:**  
Salt Factory before refurbishment,  
[www.zollverein.de](http://www.zollverein.de)

**Figure 3:**  
3D Bim model of Salt Factory, from Revit

**Figure 4:**  
Embodied energy of building materials of existing Salt Factory, from One Click calculation

**Figure 5:**  
Embodied energy of added materials of refurbished Salt Factory, from One Click calculation

## References

[1] Suedstudio. Available online: <http://suedstudio.de/work/schaudepot/> (accessed on 1.2.2022)





How much environmental impact the materials have when we build Salt Factory?

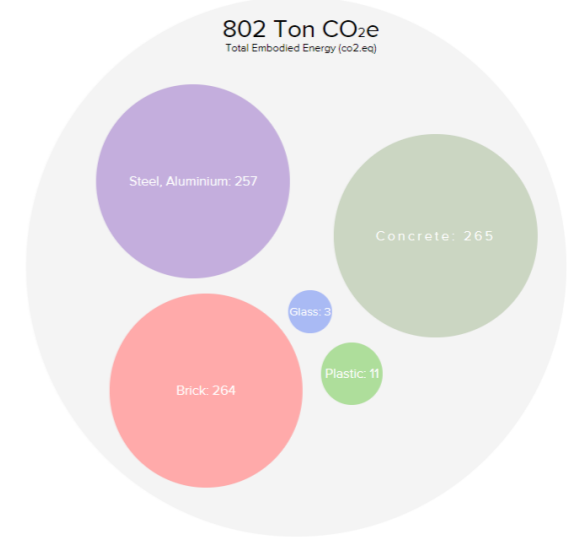

more →

Figure 4

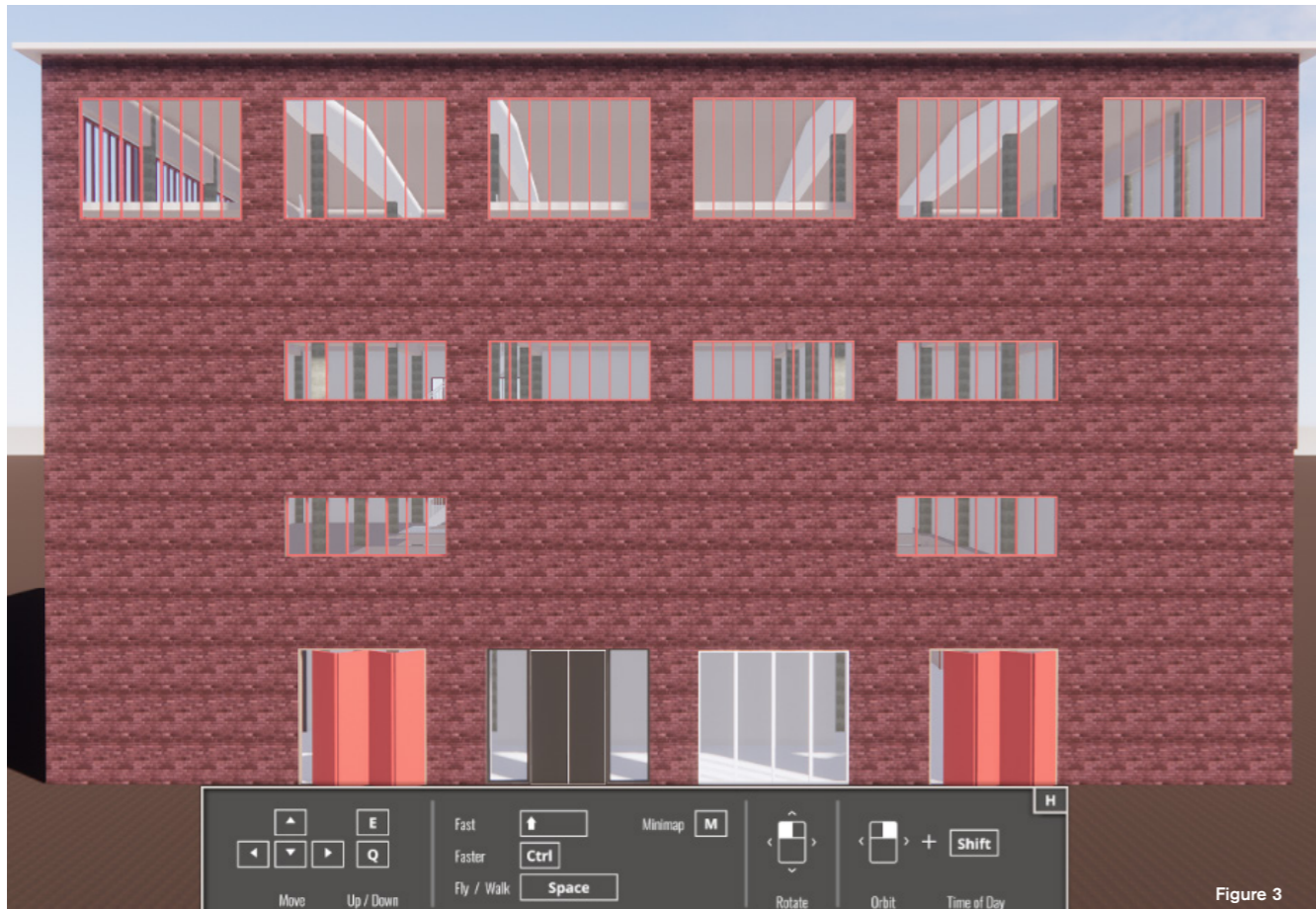

How much environmental impact the materials have when we refurbish Salt Factory?

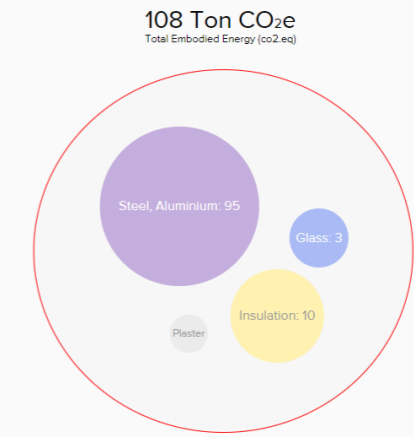

more →

Figure 5

# THE REVIVAL OF THE WORLD'S FIRST SOLAR POWER PLANT IN EGYPT

AHMAD ELNOSSERY , BASIM AL-MOUSA  
& MAHMOUD ABDELGHANY



Figure 1

## Idea

Egypt is the first country in the world to enter the field of solar and renewable energy by establishing the first solar power plant in the whole world in 1913 [1]. Regrettably, there is no existence of the industrial heritage as a heritage category in the Egyptian Ministry of Antiquities [2]. So, how do we highlight the circumstances that led to an efficient and first-of-its-kind project to happen, succeed, then get forgotten?

## Methods and Tools

There were some challenges in finding the most adequate tool to document and revive the first solar plant in the world. Especially, since all the solar collectors were recycled into weapons during the first world war, and nothing remains of the site, as it has turned into a residential neighborhood. Based on that, making a website can be the generator for preserving this first-of-its-kind industrial heritage and its history. The website will serve as a window that tells the historical story of the project from the first spark to its end. Through a 3D model that can be viewed by the website's visitors, realistic before and recent site photos, the tale of the project, and showcasing the influences of the solar plant on the Maadi planning history.

## Outlook

This website will allow communities around the world to explore all the remaining facts about the world's first solar power plant. Not only this, it will also highlight the importance of industrial heritage as a heritage category that is worth for the local government and as a cultural heritage that can be documented by UNESCO. This website is considered a practical initiative to support this heritage and document its widespread features, which are industrial, social, and cultural evidence of a civilized building journey that began with the establishment of the country and continues to this day.



Online  
<https://moudthebuilder.wixsite.com/solarpowerdawn>

**Figure 1:**  
3D rendered model for the old solar cells

**Figure 2:**  
Rebbered top view for the 3D model

**Figure 3:**  
Blended image between the new 3D model and old perspective shots for the original project

**Figure 4:**  
Placing the the 3D model in its original place on the map , Lazout view for the current map of Maadi from google earth.

## References

[1] The New York Times. (1916, July 2). American inventor uses Egypt's sun for power; appliance concentrates the heat rays and produces steam, which can be used to drive irrigation pumps in hot climates. The New York Times. Retrieved January 29, 2022, from <https://www.nytimes.com/1916/07/02/archives/american-inventor-uses-egypts-sun-for-power-appliance-concentrates.html>

[2] Ministry of Antiquities Portal. (n.d.). Retrieved January 29, 2022, from <http://antiquities.gov.eg/DefaultEn/Pages/default.aspx>



Figure 2



Figure 3



Figure 4

# MECHANICAL SYSTEMS IN ARCHITECTURE

BENEDICT NEISE, JESSICA MOLDENHAUER  
& VITALIJ GÖTTMANN

## Idea

The MoMo architects were influenced by industrial mechanical systems. They added industrial inspired elements to their design and transferred them to other uses like residential buildings. This technology changed over the century from a functional use to a design element [1].

Our research showed that the documentation of these systems is either insufficient or not existent. Literature and photographs about mechanical systems exist, nevertheless, they are very complex and unspecific [2]. Additionally, the history and functionality of existing architectural systems aren't well enough explained and collected in a single source.

## Methods and Tools

We pursue the idea of creating a database that connects facts about the architecture, mechanical systems and their history. People should be able to learn from the past and rediscover systems, they may use in their building. It should be understandable for everybody and give inspiration. We want to create an extensive learning process by presenting the building, the system which is built-in and giving the chance to rebuild the mechanical system in a model version.

We work with the website Wordpress to make it accessible. The building models are made with the 3D modelling program Rhino. Animation is made with Cinema 4D and finally, it is uploaded to Sketchfab, a 3D Modell platform. The 3D models of the associated buildings show the complex mechanical process as an animation to make it more comprehensible to the viewer. On the website implemented filter gives the opportunity to search for special parts or functions. For the theory part, we are describing the basics of mechanical systems and functions in text and pictures using simple words to include everyone. For a haptic experience and a better understanding of the mechanical principles the Fischertechnik construction set is used to build small models of the systems which are used in the buildings. Besides, the instruction comes with a material list which is made with Fischertechnik Designer, a construction software for Fischertechnik models. Thus, it will be possible to order exactly the same elements which are needed to build the small models.

The website is created in a way that makes it easy to use and possible to add new input and more information about the included architecture. Through this combination of digital information and analogous homemade systems, an all-around learning process is possible. Moreover, a collected database with detailed information is created and gives a direct focus to these mechanical systems.

## Outlook

The database can be increased with additional buildings and details about the mechanical systems. The architectural dimension is not predetermined. Next to elevators and escalators, water powers could be added for example.

**Figure 1:**  
Chicken Point Cabin - Benjamin Benschneider - Source: [www.archdaily.com/778809/chicken-point-cabin-olson-kundig](http://www.archdaily.com/778809/chicken-point-cabin-olson-kundig)

**Figure 2:**  
Chicken Point Cabin Drawing - Olson Kundig - Source: [www.atlasofplaces.com/architecture/chicken-point-cabin/](http://www.atlasofplaces.com/architecture/chicken-point-cabin/)

**Figure 3:**  
3D modell - authors

**Figure 4:**  
Fischertechnik modell - authors

## References

[1] Fox, Dirk & Püttmann, Thomas. 2017. Technikgeschichte mit fischertechnik. Heidelberg: dpunkt-Verlag. ISBN 978-3-86490-296-3

[2] Wittel, Herbert et al. 2015, 22. Auflage. Maschinenelemente: Normung, Berechnung, Gestaltung. Wiesbaden: Springer Verlag. ISBN 978-3-658-09082-1



Figure 1



Online  
<http://documomo-mechanics.great-site.net/>

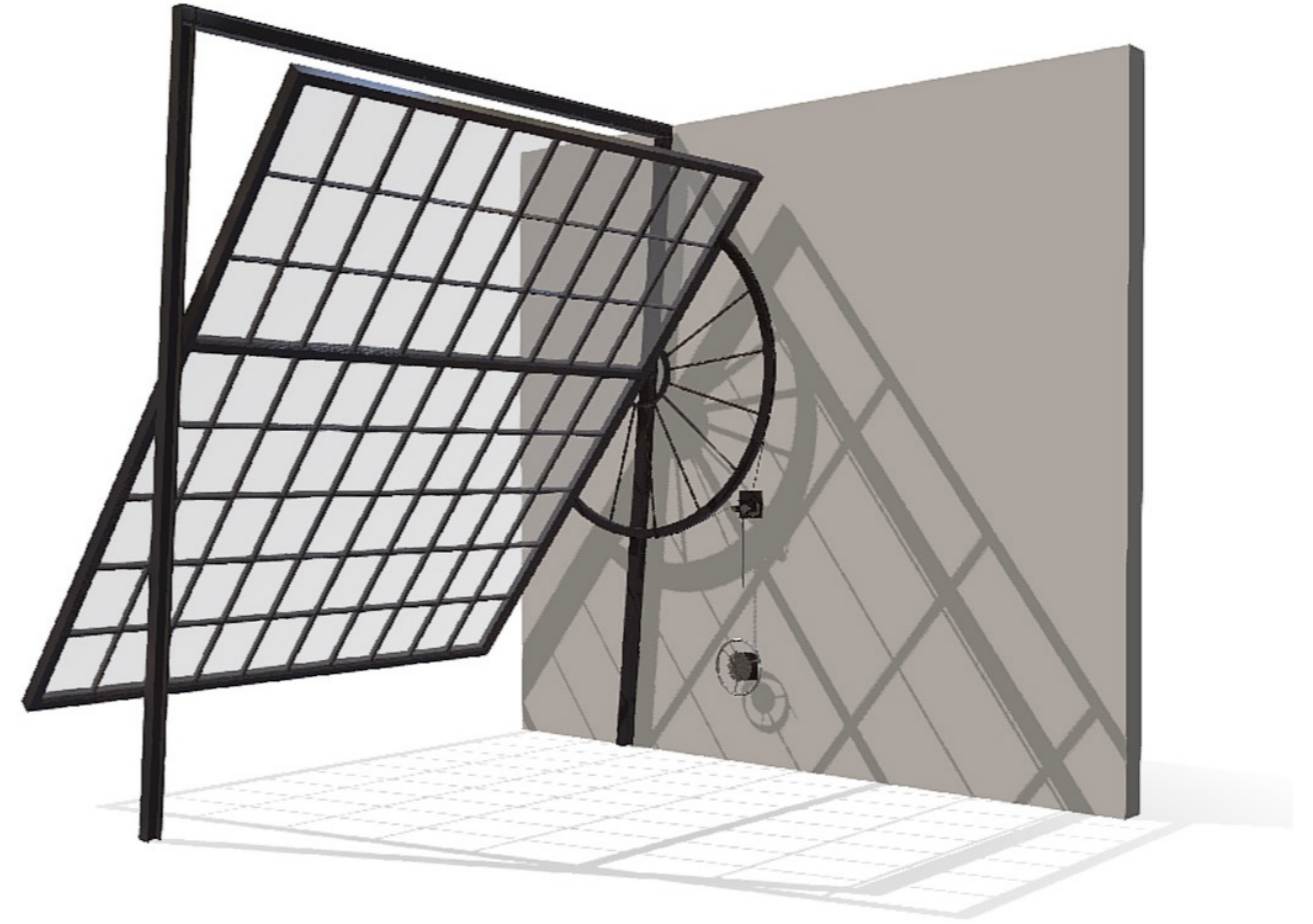
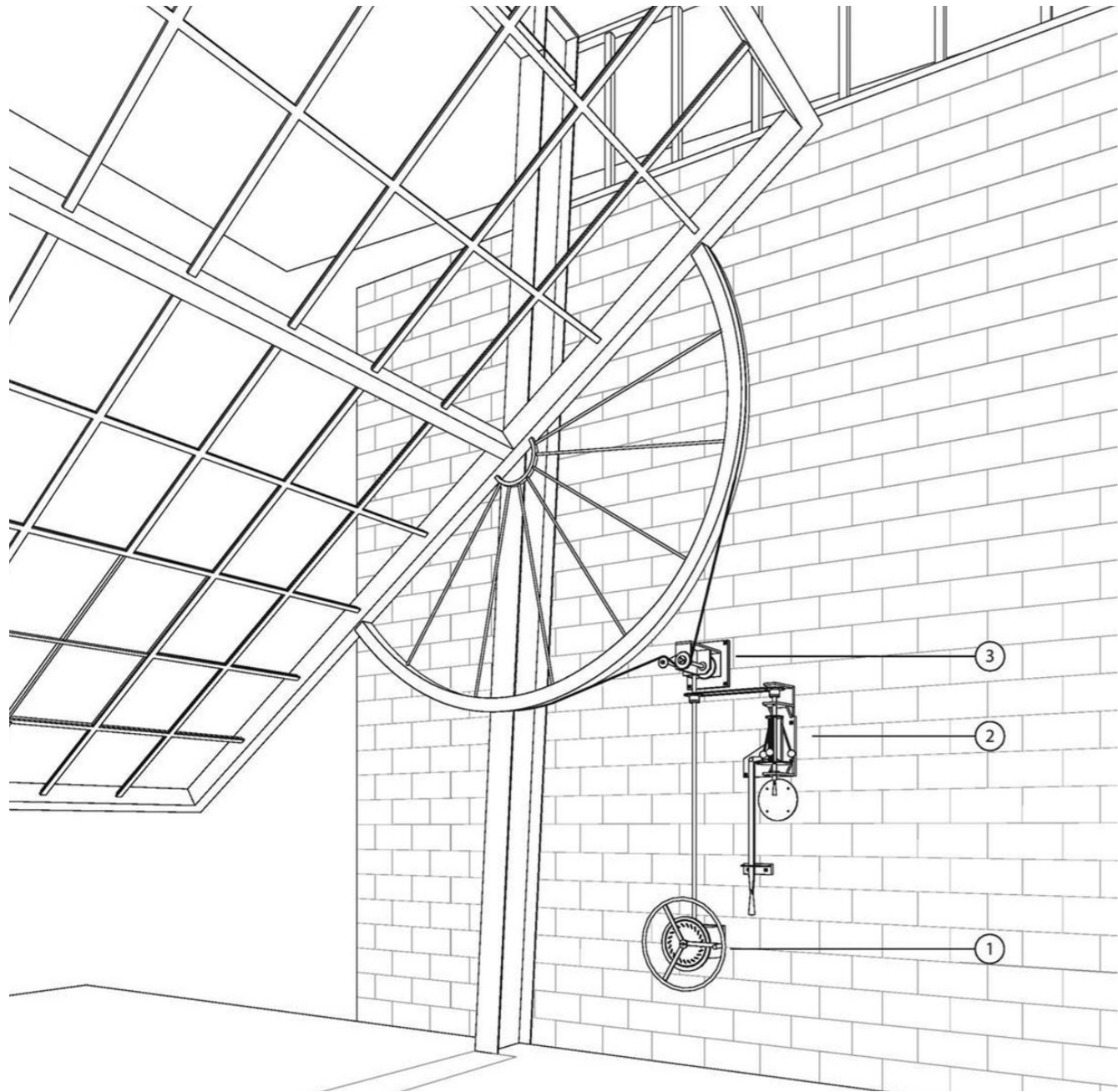

Figure 3

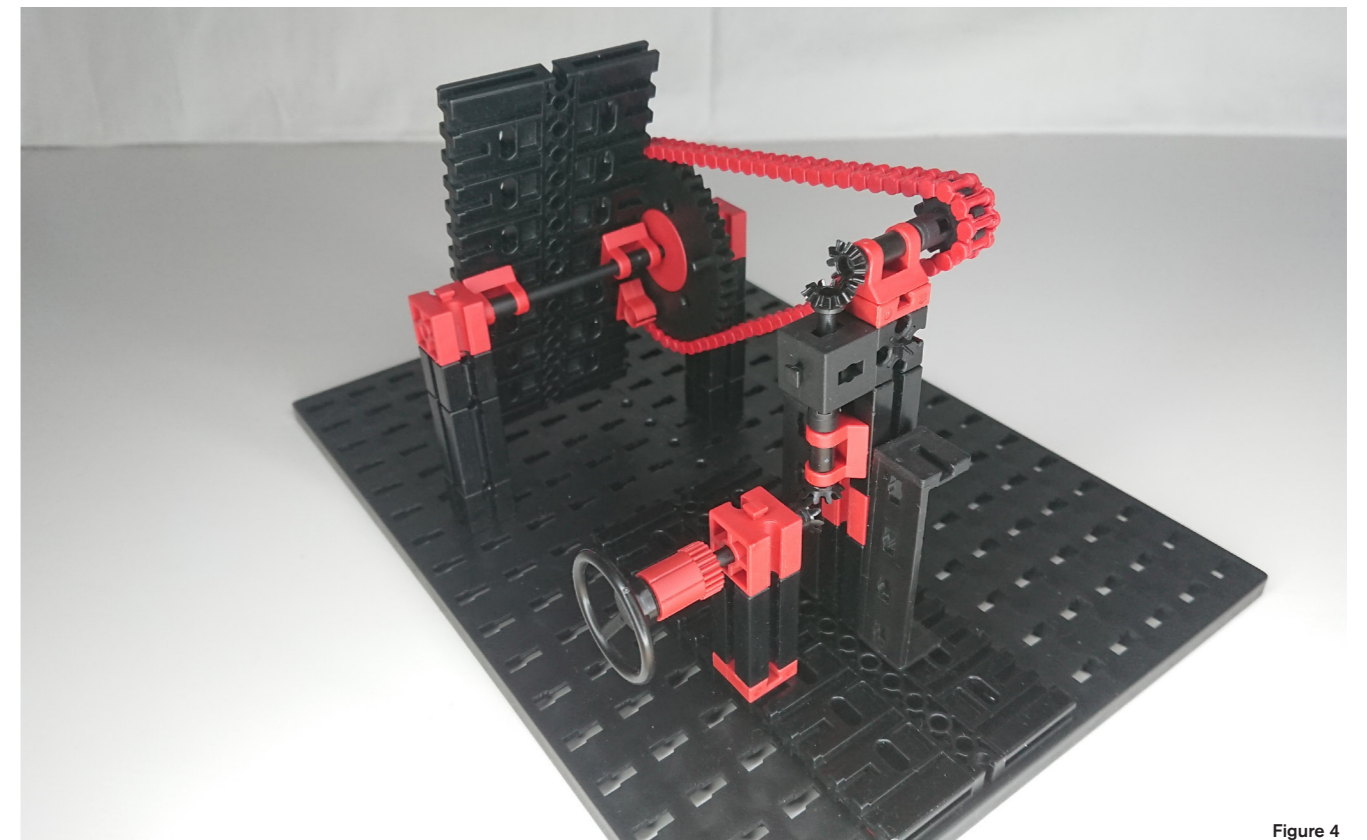
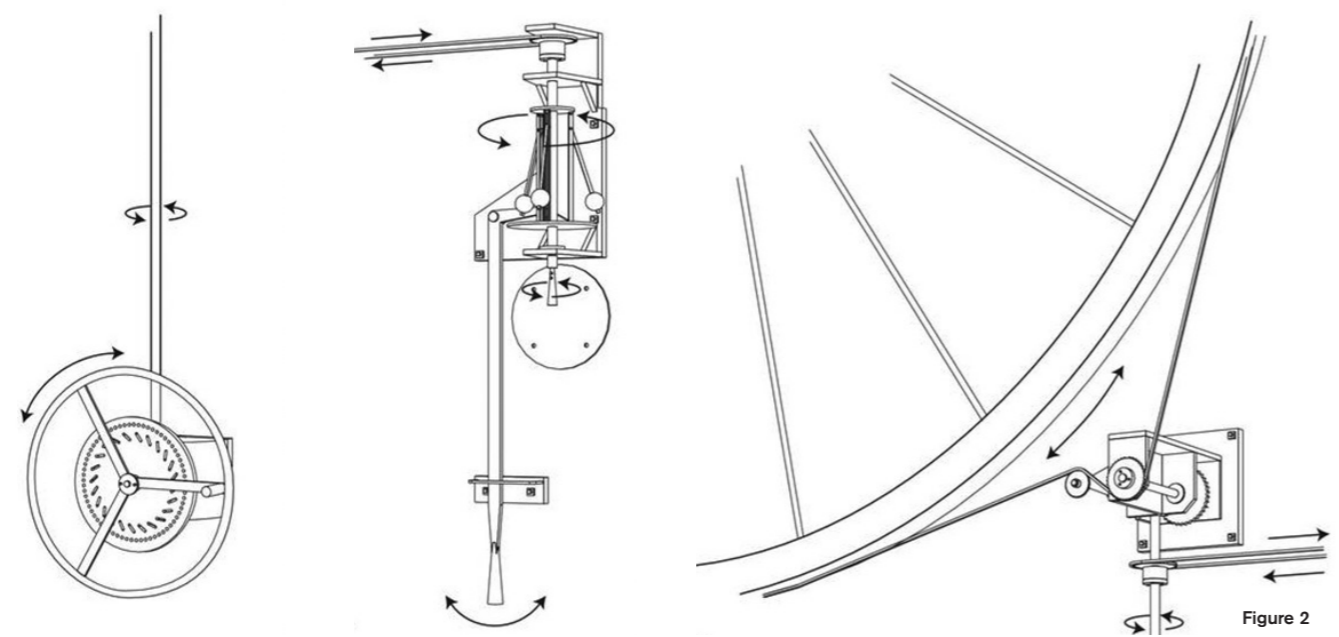

Figure 4

# GROPIUS' FAGUS WERK AESTHEHTICS

LEON KONSCHAKE, MAXIMILIAN KIRCHHOFF  
& LEON LANDWEHR

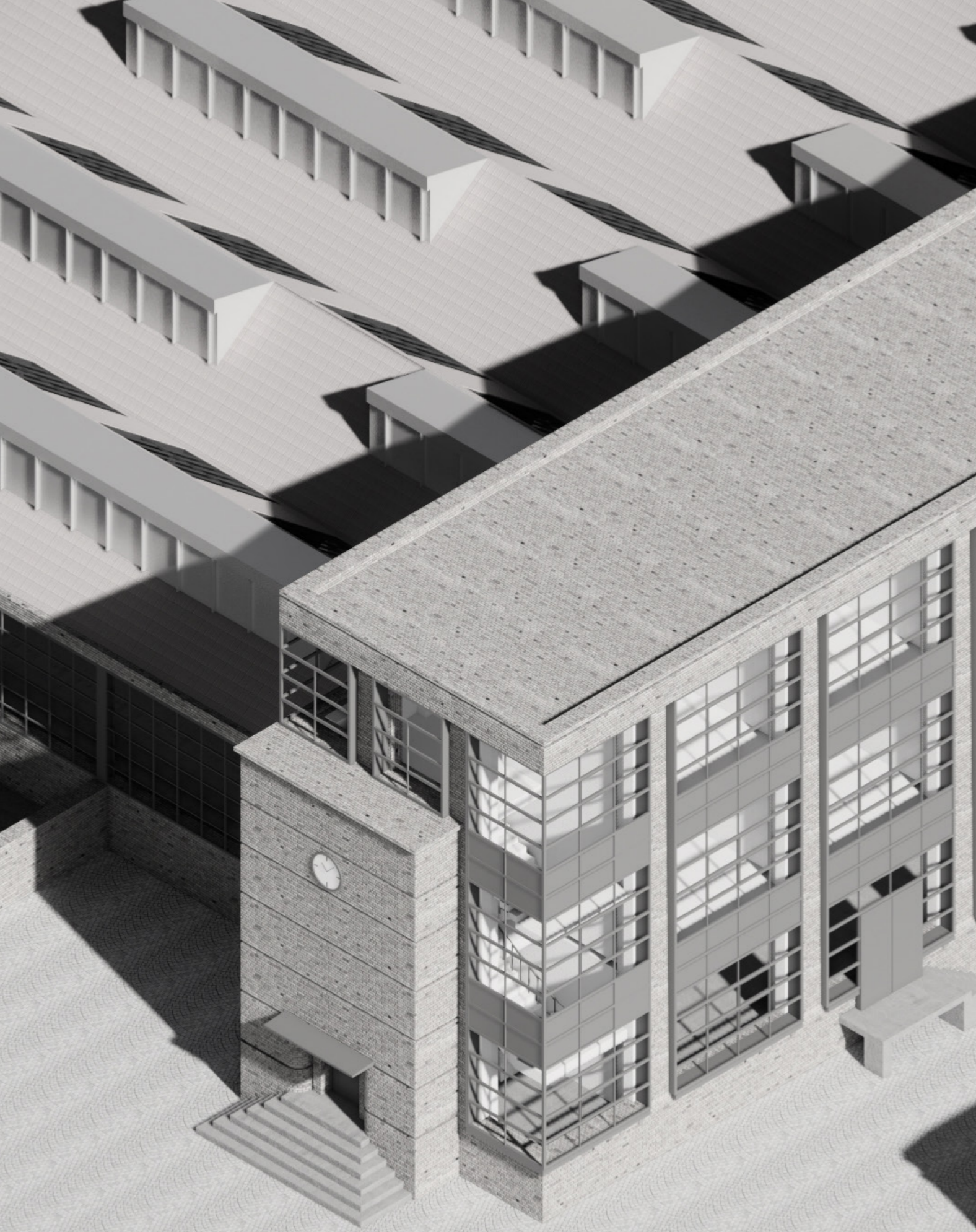

Figure 1

## Idea

In order to create a digital exhibit based on the abstract previously developed, the first step was to research possible forms of the exhibit. It was important to us to emphasize the visual aspect. So we decided to represent the legendary building of modernism in the form of images, videos and animations on a website

## Methods and tools

Because of our fascination with the Fagus Werk, we went on a private expedition to Alfeld and visited the UNESCO World Heritage Site. In addition to photos and videos, we were able to take 360 degree pictures, generate more detailed information from the staff and get a personal picture. Furthermore, we used a virtual 3D model of the Fagus Werk as part of the representation. This digital copy allowed us to demonstrate important construction details more accurately, visualize the play of light and shadow, and better understand and depict the various construction phases. There is already a model available for purchase on the Internet, but it is poorly modeled and very incomplete. For this reason we built our own which helped us to understand the building even better. The collected data was displayed on a website. We divided the Fagus Werk into the most important sections and developed four main topics: the construction phases, the entrance hall, the facade and the workshops. These four main themes and general information form the foundation of the website. They can be found on the home page and are represented by concise images that function like tiles behind which information is hidden. We wanted to present information about the main topics not as text or photos but in a more dramatic, exciting way. We decided to create videos that on the one hand convey visuals but at the same time tell facts.

## Outlook

From the first idea, to the collection of information, to the finished website, it was a long creative journey that didn't always go in one direction. We had to try out many ideas and then discard or modify them. This way of working has definitely helped us to learn how to visualize and represent architecture, whether ancient, modern or newly built. With this skillset we will definitely confront future tasks with more confidence and be able to manage them in a much more professional way.



Online  
<https://docomomofaguswerk.wixsite.com/official>

**Figure 1:**  
isometric render of 3D Model - Fagus Werk

**Figure 2:**  
groundfloor plan - Fagus Werk

**Figure 3:**  
first floor - Pixabay

**Figure 4:**  
picture of rotating window - Fagus Werk

## References

[1] 1. Claussen, Horst, (1986). Walter Gropius, Grundzüge seines Denkens

[2] Nerdinger, Friedrich, (1996). Der Architekt Walter Gropius

[3] Lupfer, G. und Siegel, P. (2006). Gropius

[4] <https://www.fagus-werk.com/de/>, [online]

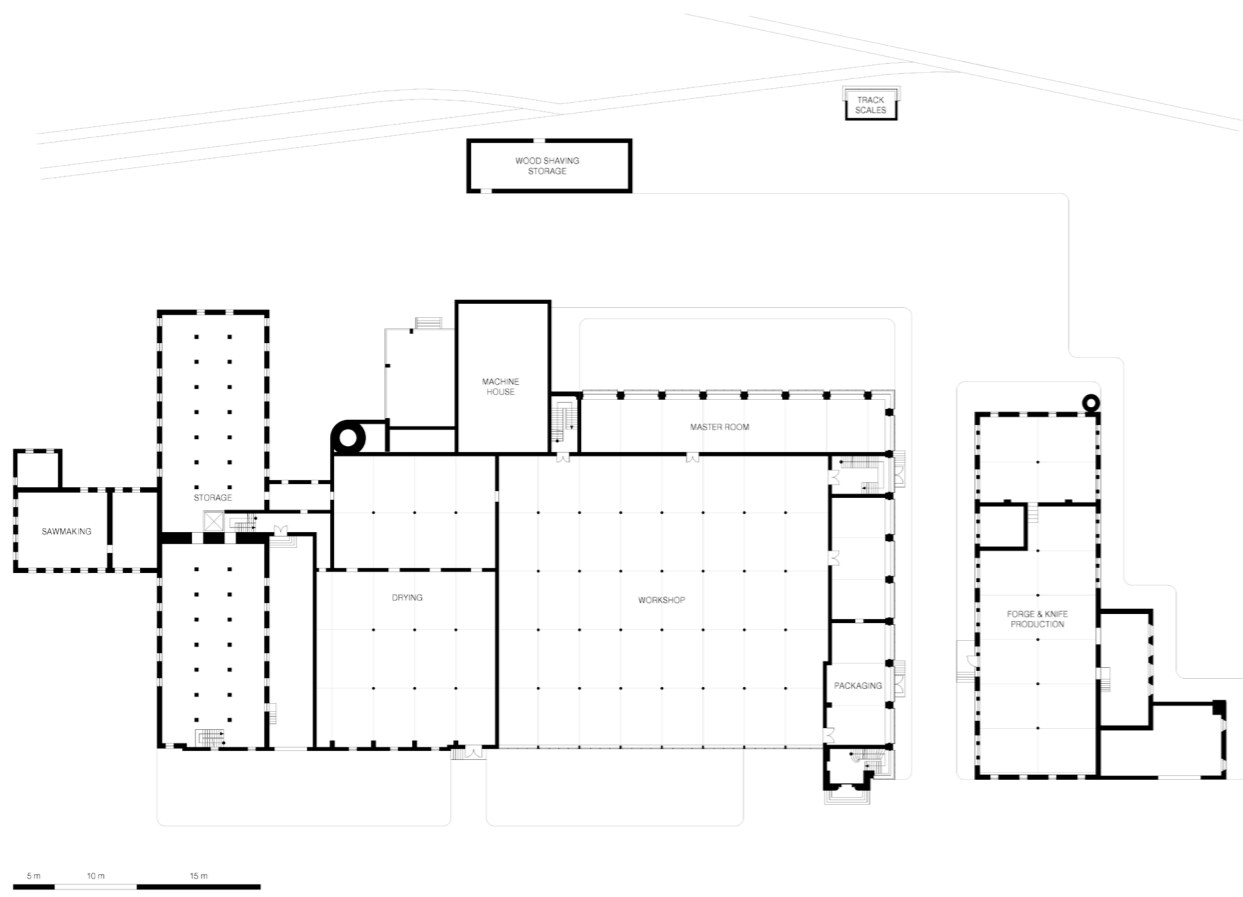

Figure 2

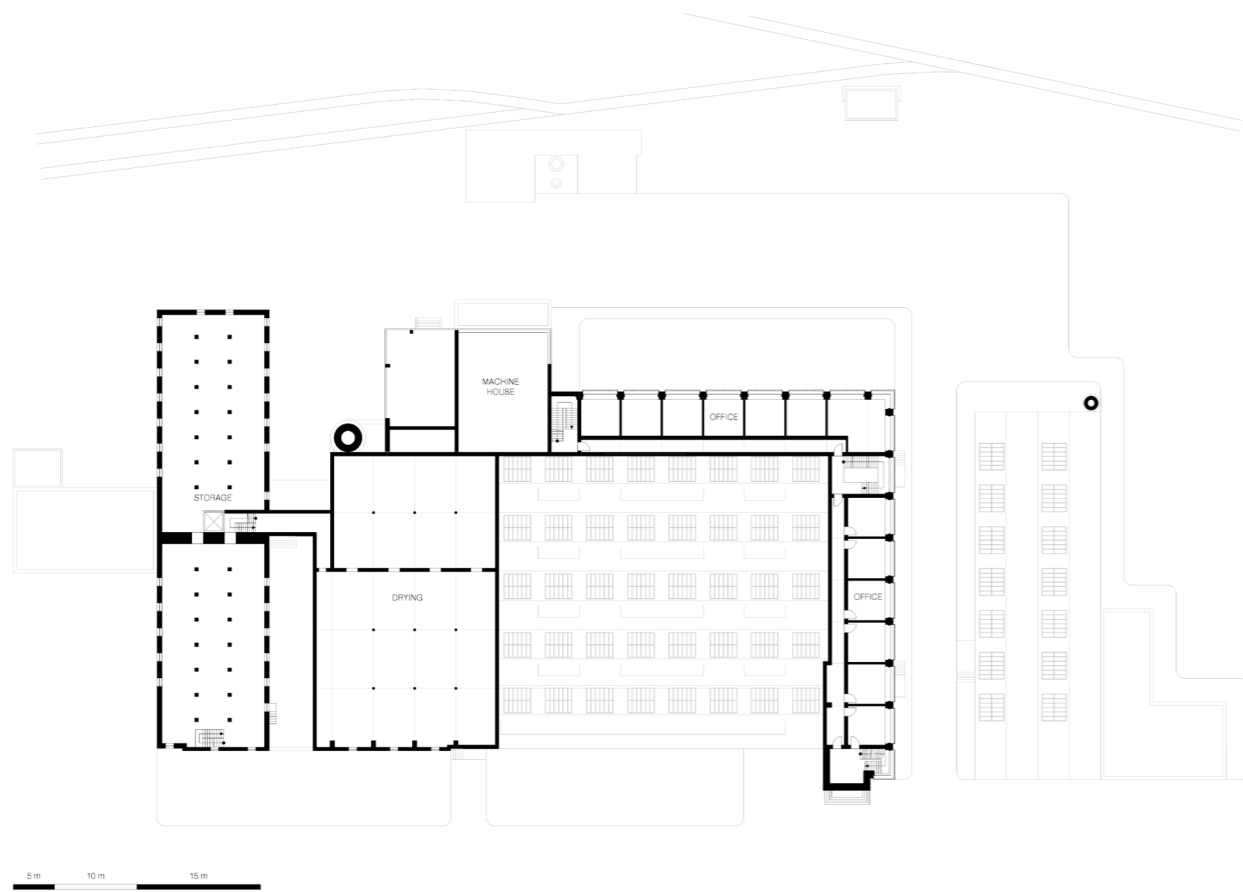

Figure 3



Figure 4

# INTRODUCTION TO THE AESTHETICS OF THE ZOLLVEREIN COLLIERY SCHACHT XII

REGINA KLIPPENSTEIN, LENA BECKERVORDERSANDFORTH,  
ANDRÉ POPP & FRAUKE FISCHER



Figure 1

## Idea

Almost 100 years ago, Zollverein Schacht XII went into operation as the most powerful mine in the world. About 50 years ago, the last piece of coal was extracted up there and work was stopped. Today, the site and the building complex are part of the UNESCO World Heritage and are visited by many people from all over the world.<sup>1</sup> In addition to visiting a historically important place, the aesthetic perception of the architecture and the resulting appreciation also play an important role. The appreciation of the Zollverein colliery has been increasingly judged on objective aspects, such as historical and architectural value. Thereby the reference to the subjective perception of the Zollverein visitors is missing, which is why the content of the website focuses on this aspect.

## Methods and Tools

With an overview of the historical events at Zeche Zollverein, the key moments in the process of change, such as the closure of the shaft in 1968<sup>2</sup>, are highlighted. The highlights introduce the topic of changing perception on the contextual level. On the theoretical level, the basics of human perception are explained and illustrated in a practical way using images of Schacht XII. With the help of different approaches to the aesthetics of the shaft, a discussion on aesthetic perception emerges. In addition to statements by the architects, Fritz Schupp and Martin Kremmer, who are of the opinion that „the industry with its enormous buildings is no longer a disturbing link in our cityscape, [...] but a symbol of labor, a monument to the city“<sup>3</sup>, statements by other experts and contemporary witnesses are consulted. These refer both to the process of the creation of Schacht XII and to the change of external influences around Zollverein and thus describe the turgid change of aesthetics. The discussion confirms the approach of the perception theory that perception depends on the individual experiences of a person and that aesthetics is subjective.

## Outlook

With this website a digital handbook for understanding the aesthetics of Zollverein Schacht XII has been created. Through the final survey among the visitors of the website, a pool of results is to be created that shows the connection between aesthetic perception and personal experience or distance to the Zollverein colliery. Thereby, the subjective aspect of the appreciation of Zollverein will be elaborated and will lead to an extended and more sensitive assessment of the world heritage.



Online

[www.aesthetik-schacht12.wixsite.com/zxii](http://www.aesthetik-schacht12.wixsite.com/zxii)

**Figure 1:**  
Photography of the Doppelbock of Schacht XII in the snow flurry - photo by Kai Pilger of Pexels

**Figure 2:**  
Main axis with design principles - rottenplaces.de

**Figure 3:**  
Minor axis with design principles - fotocommunity.de ; Foto von r thier-grebe

**Figure 4:**  
Hand drawing by Fritz Schupp - Landschaftsverband Rheinland

**Figure 5:**  
Isometric drawing by Fritz Schupp - rheinische-industriekultur.de

## References

[1] Rainer, Slotta. 2002. Symmetrie und Symbol: Die Industriearchitektur von Fritz Schupp und Martin Kremmer – Ein Bergwerk muß fördern– Die betrieblichen Voraussetzungen für die Tagesanlagen.

[2] Rainer, Slotta. 2002. Symmetrie und Symbol: Die Industriearchitektur von Fritz Schupp und Martin Kremmer – Ein Bergwerk muß fördern– Die betrieblichen Voraussetzungen für die Tagesanlagen.

[3] Schupp, Fritz, and Kremmer Martin. 1929. "Architekt gegen und oder Ingenieur"

**Further references for the website**  
Busch, Wilhelm; Scheer, Thorsten. (2002): Symmetrie und Symbol. Die Industriearchitektur von Fritz Schupp und Martin Kremmer. Köln: Buchhandlung Walther König

Schupp, Fritz; Kremmer, Martin. (1929): Architekt gegen oder und Ingenieur. Berlin: W. & S. Loewenthal, Verlag „Die Baugilde“

Grütter, Jörg Kurt.(1987): Aesthetik der Architektur, Grundlagen der Architektur-Wahrnehmung. Stuttgart: Kohlhammer

Bense, Max. (1965): Aesthetica: Einführung in die neue Ästhetik. Baden-Baden: Agis-Verlag

Hagendorf, H.; Krummacher, J.; Müller, H.; Schubert, T.(2011): Wahrnehmung und Aufmerksamkeit. Heidelberg: Springer-Verlag Berlin

Ansorge, Ulrich; Leder, Helmut.(2011): Wahrnehmung und Aufmerksamkeit. Verlag für Sozialwissenschaften

Bockemühl, Michael; Van Den Berg, Jörg; Van Den Berg, Karen.(1997): Zeche Zollverein Schacht XII in Essen: Gebauter Gedanke. Ostfildern: Verlag edition tertium



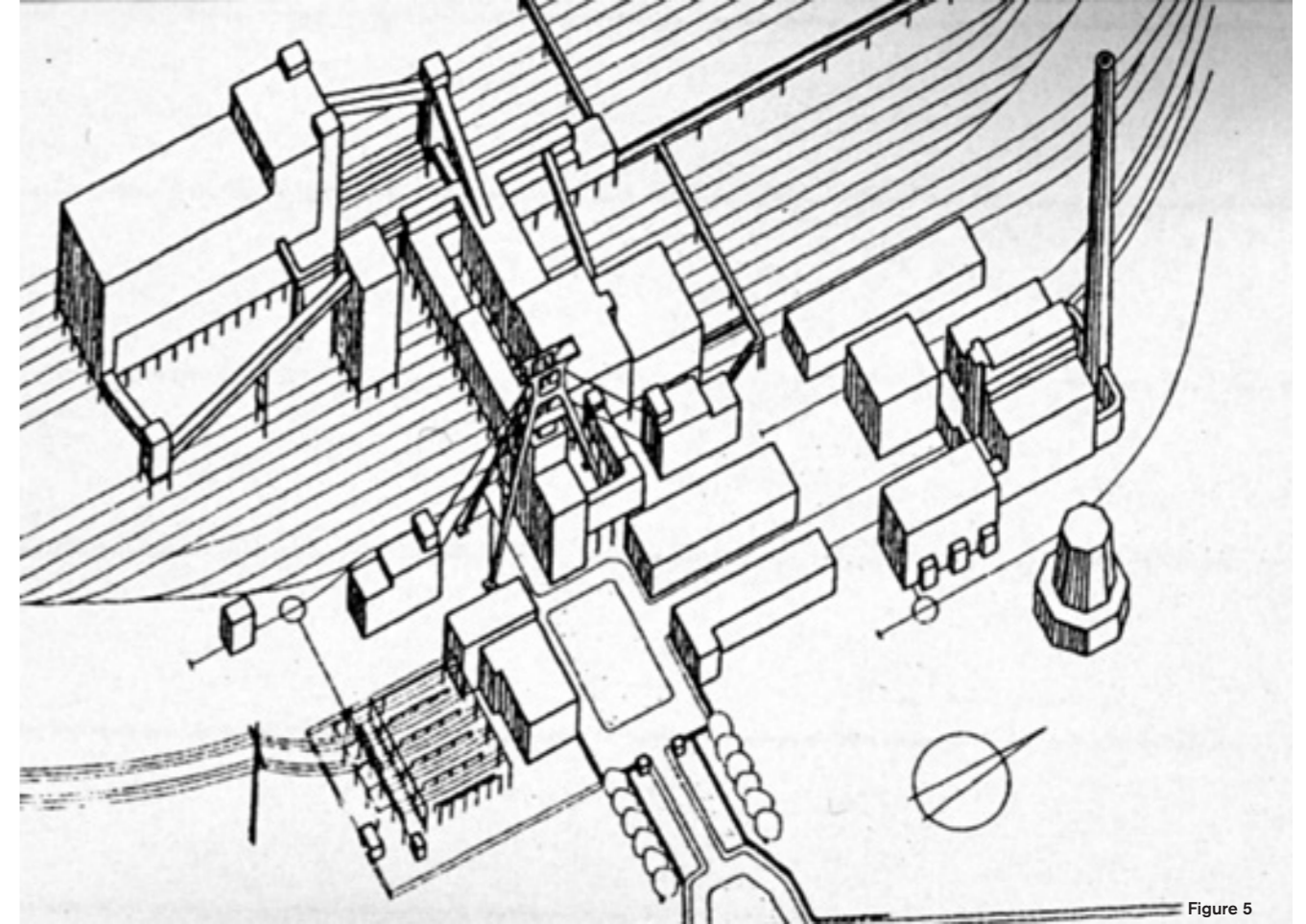
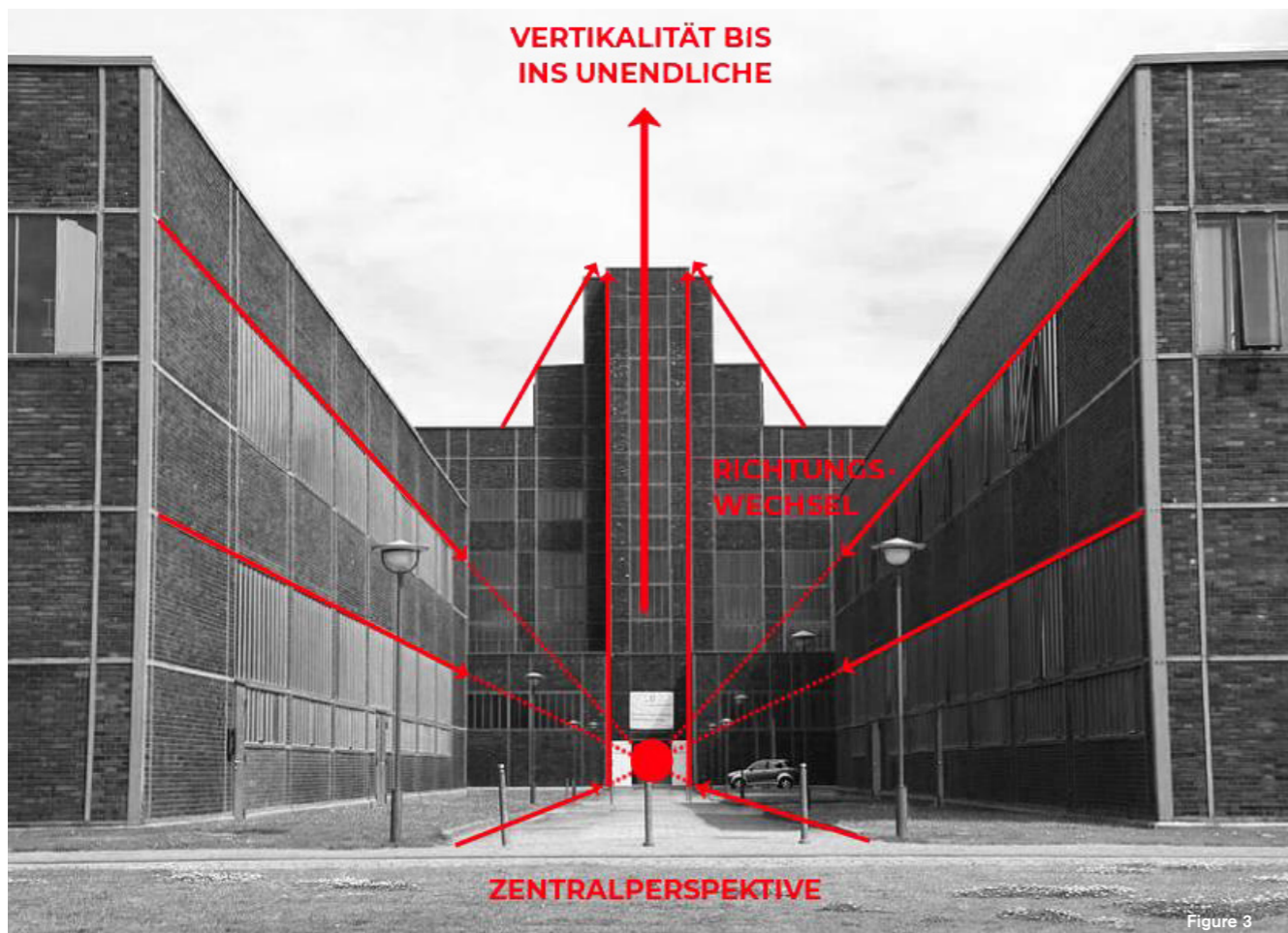
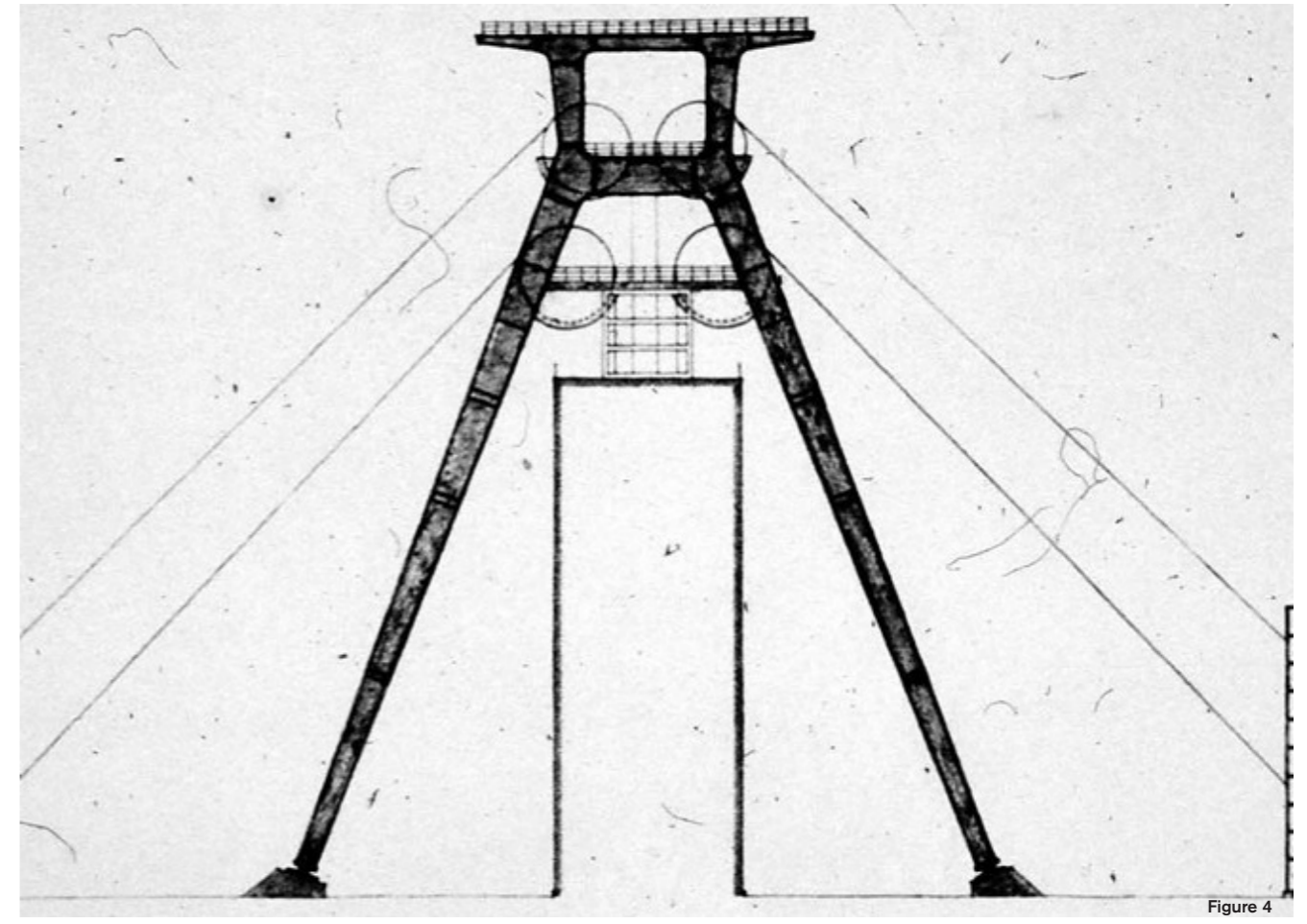
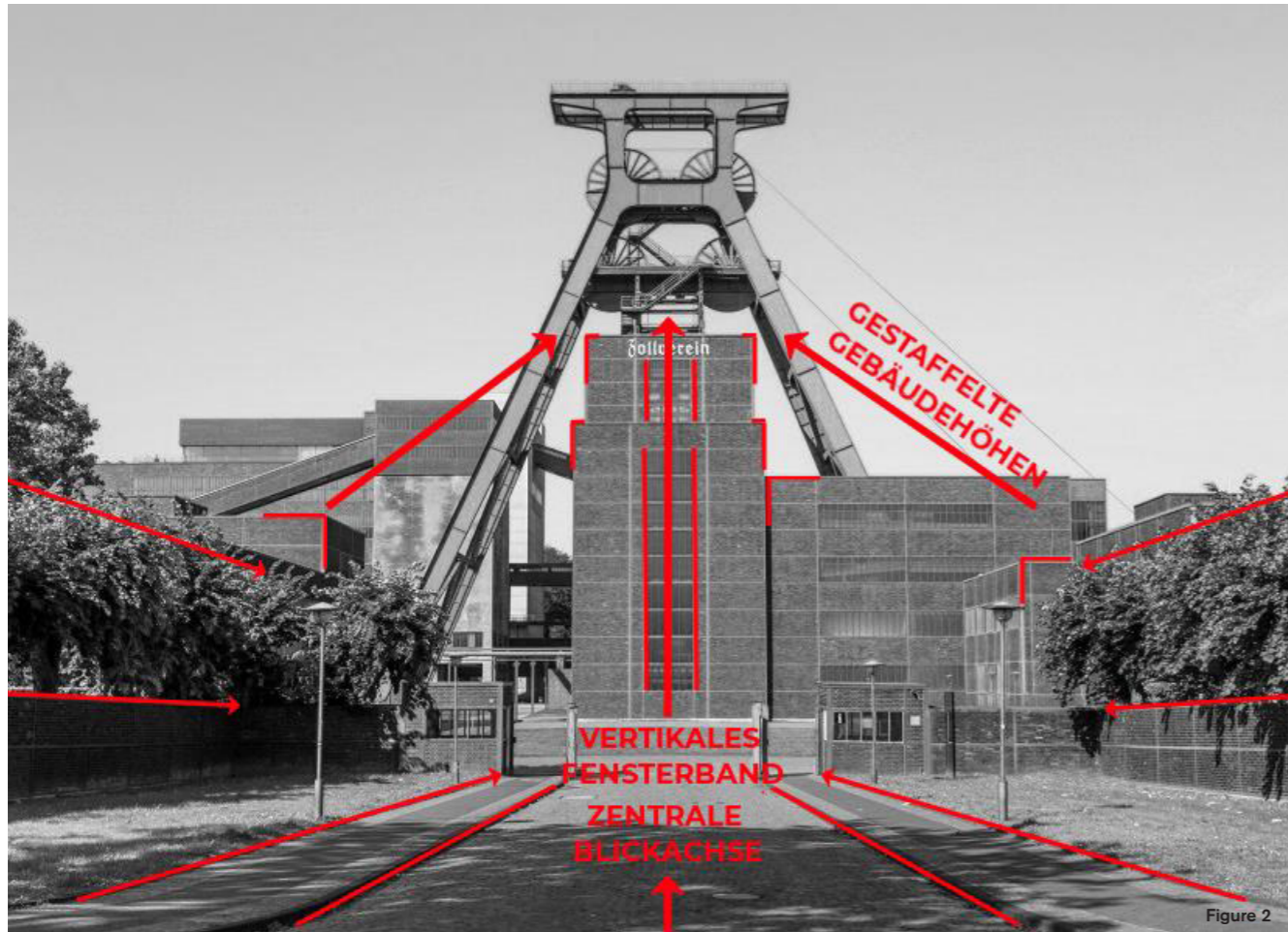

# DIGITALIZATION HERITAGE BUILDING WITH PHOTOGRAMMETRY

CHARNELE LUKMAN & MAHAN MASHAYEKH

## Idea

Archiving and documenting cultural heritage sites, which could be possibly destroyed or altered, is necessary to preserve cultural heritage beforehand. Historic elements and buildings may be obscured or limited by renovation and maintenance works, destroyed by natural phenomena, or inaccessible to the public due to geographical restrictions. We focus on the correlation between criteria such as accessibility, time, and cost in terms of quality and practical amenity application. People assume that more recent and expensive technology will deliver better performance with the digital world evolving rapidly. However, devices around us are now adequate to provide high-tech processes.

Data repositories provide the opportunity to access heritage sites and experience them as they should be perceived. The visualization of the project explores how data storage can assist in disseminating data, immersion in industrial heritage sites, and the representation of intangible cultural heritage.

## Methods and Tools

The first step was to rethink how to implement an approach where no special equipment is required, and only daily life items are being utilized to generate a 3D configuration. Photogrammetry is one of the solutions, which only requires a smartphone to create a sequence of images over an object or location and generate the point cloud with programming-based software. In this method, As more data, such as images, are collected, the 3D results get more precise and similar to the real-world objects.

Photogrammetry obtains reliable information about physical objects and the environment through recording, measuring, and interpreting photographic images and patterns of electromagnetic radiant imagery. And by utilizing Python Open Library, it generates the image sequences into point cloud and mesh.

## Outlook

We provided a website that users can access with any electronic device. The user is transported to another virtual world within this platform, initiates the heritage location, selects the site, and is linked automatically to the drive system to upload personal images. As a counterpart, they experienced virtual reality in point cloud representation. This website also acts as a forum for the heritage community to create a new tourism heritage. Throughout the time, it will expand into multiple heritage sites worldwide, push preservation and promote cultural heritage to be introduced to new generations, and urge them to participate in history.

For further development of this project, a server is required that processes all images in a cloud platform and automatically creates augmented three-dimensional configuration, which in this context are point cloud and Virtual Reality visualization.



WEBSITE



VR

Online

<https://people-dir.wixsite.com/docomomo-dir>

**Figure 1:**  
Zollverein, 3D Point Cloud Visualization

**Figure 2:**  
Method Diagram

**Figure 3:**  
Zollverein, Initial Point Cloud

**Figure 4:**  
Website Integration in Electronic Device

## References

[1] Salazar Miranda, A., Du, G., Gorman, C., Duarte F., Ratti C., & Fajardo W. (2021). Favelas 4D: Scalable methods for morphology analysis of informal settlements using terrestrial laser scanning data.

[2] Schläpfer, M., Dong, L., O'Keefe, K., Santi, P., Szell, M., Salat, H., An-klesaria, S., Vazifeh, M., Ratti, C., and West, G.B. The universal visitation law of human mobility Nature 593, 522–527 (2021).

[3] Hain, V., Löffler, R. and Zajiček, V., (2016). Interdisciplinary Cooperation in the Virtual Presentation of Industrial Heritage Development. Procedia Engineering, 161: p. 2030–2035.

[4] Scianna, A., Gaglio, G. F. and La Guardia, M., (2019). Augmented Reality for Cultural Heritage: The Rebirth of a Historical Square. The International Archives of the Photogrammetry, Remote Sensing and Spatial Information Sciences, XLII-2/W17: p. 303–308.

[5] M. Loddò, (2021). AR and VR in cultural institutions. MoMove Modern Movement and Infrastructure: Contributions to the Docomomo virtual exhibition - momove: p. 12–17

Figure 1

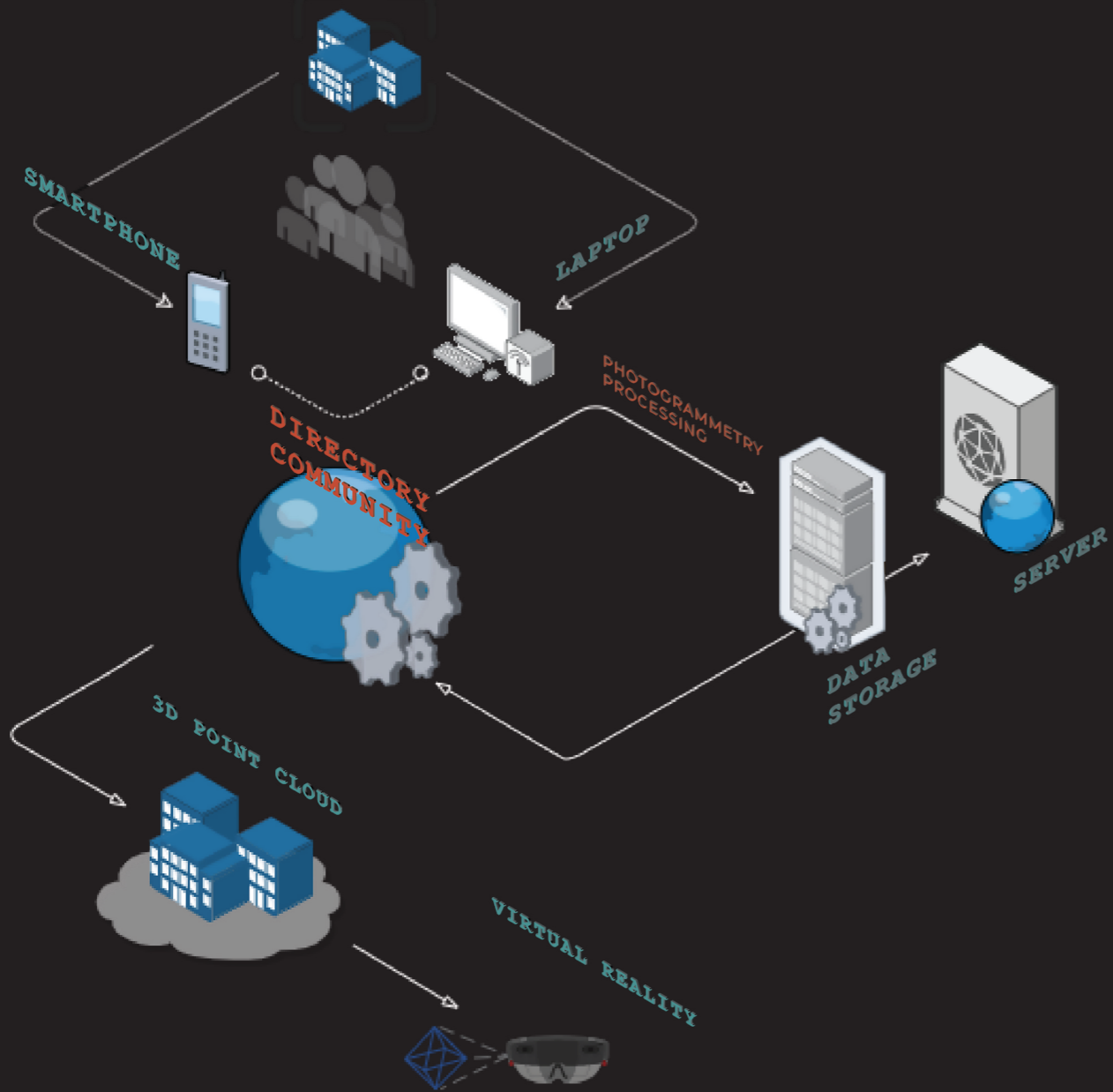

Figure 2

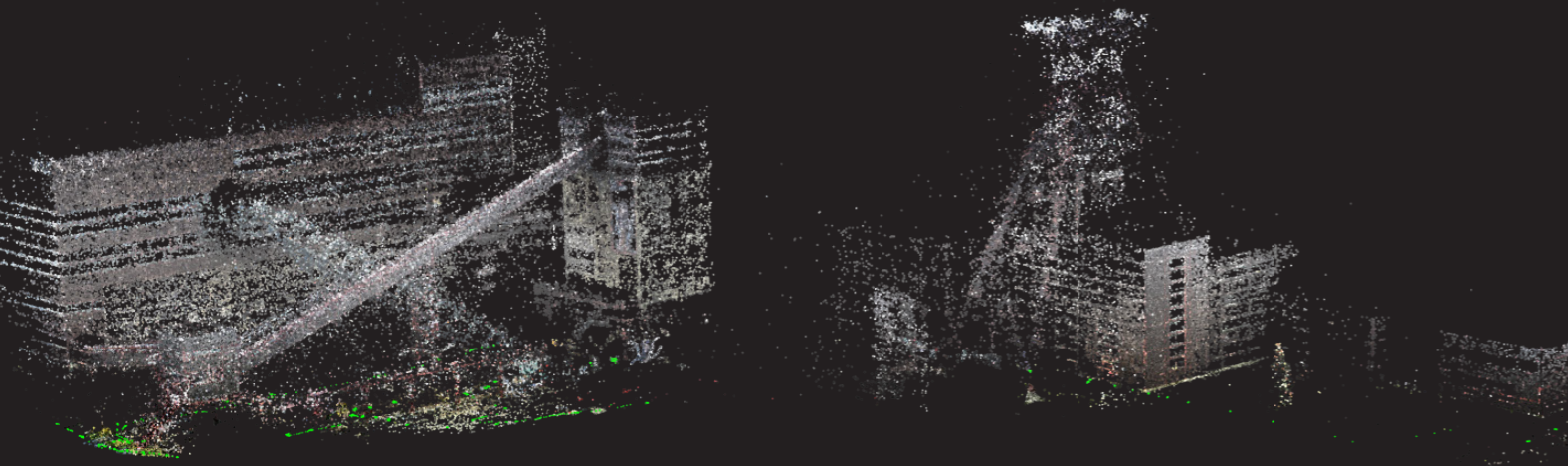

Figure 3



Figure 4

# DISSEMINATING KNOWLEDGE OF MINING PROCESS/ ACTIVITIES AT ZOLLVEREIN USING VIDEO GAMES

ANDRES BUITRAGO & GIZEM DEMIRHAN

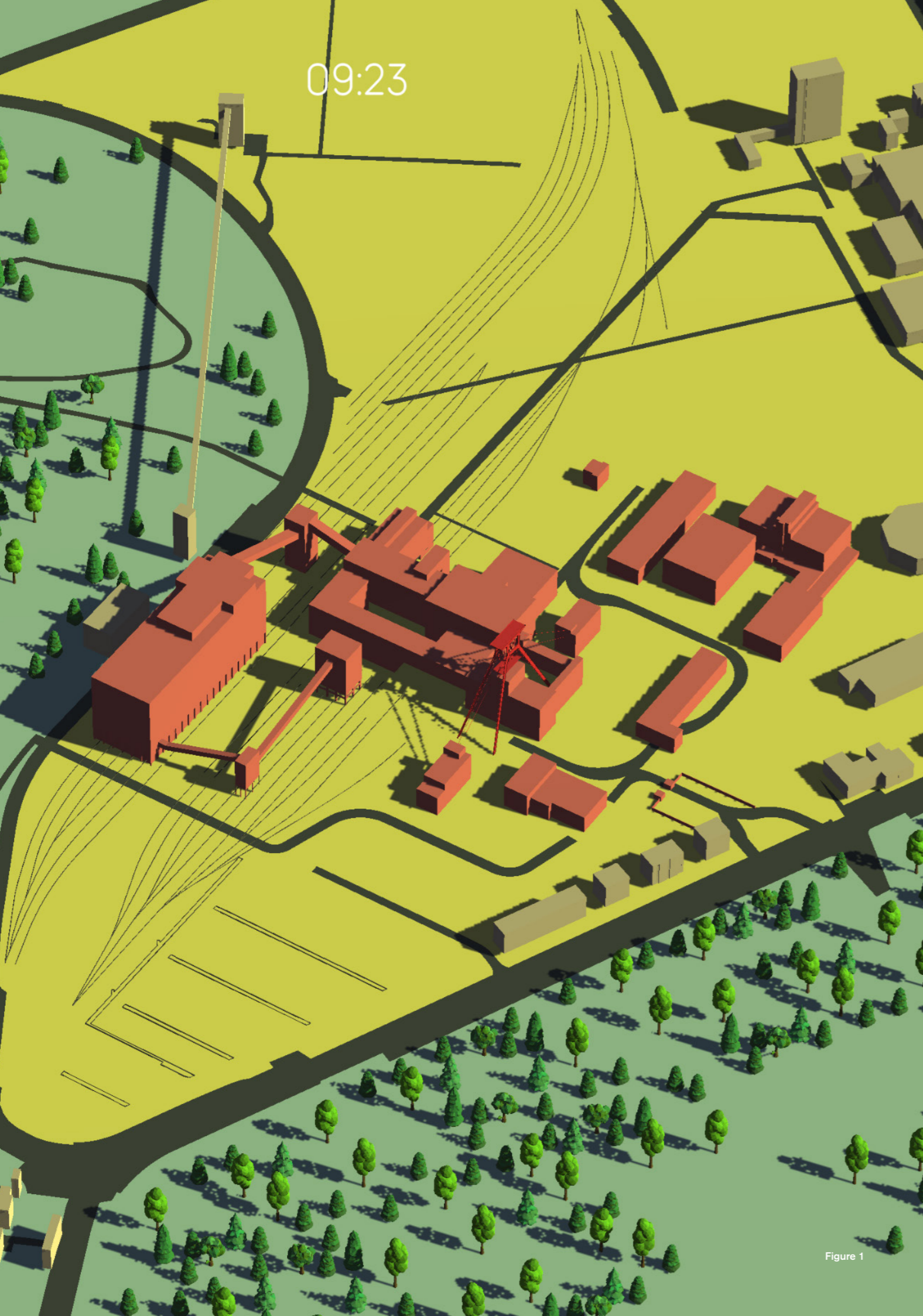

## Idea

In Germany in the 90's, as a part of a transition towards renewable energy resources, and the increasing dangers in working conditions, the operation of coal mining started to cease. Nowadays, many former mining sites have become cultural and heritage sites, where people learn the knowledge of mining, life of workers and energy resources. On the other hand, the dissemination of heritage is now more attractive and effective through interactive exhibit elements supported by VR, mobile apps and video games - as they incorporate visuals, sound, and narrative in an accessible way. Therefore, this work focuses on designing a video game for the UNESCO world industrial heritage site of Zollverein for preserving the industrial heritage.

The game is envisioned as multiple campaigns, which has the player going through different times in mining history. First the player will start at the era of coal, characterized by great extraction and expansion. Here it shows how mining was a phenomenon that reached outside of the mine, affecting sociocultural events, and shaping life of workers and their families. Second, a campaign where the player is faced with the advances in technology that meant greater production but a riskier work environment, thus forcing the player to balance the coal output and health and happiness of the workers. And lastly, the carbon neutral era where the coal extractions start to decrease due to a transition towards renewable energies, creating awareness of sustainability.

## Methods and Tools

The prototype game uses storytelling to put the player in the era of 1950's, in the position of the new manager of the mine. As such, the player needs to learn the mining process as well as the building's functions. The game lets the player interact with the buildings and guides the focus using the UI. The camera is set in bird's eye isometric view so the player can experience the whole site and change position. This makes it easy to understand the whole mine, something which given the dimension of the site is not possible in real life. We used free to use 3D models and site information from the Zollverein to achieve a realistic depiction and having the player understand the mine without being on site.

We chose the genre of business simulation (tycoon) game to better disseminate the activities of mining. This means that the core mechanic of the game is to extract coal and transform it into a product to sell, to make more money and grow the operation. We studied some examples of this game genre which also deal with the heritage knowledge such as Railroad Tycoon and Zoo Tycoon. While developing the prototype we used the Unity game engine as a tool, as it is free to use, it makes easy to collaborate in a team, and it has many resources to learn.

## Outlook

Preserving cultural and Industrial heritage is a key role in modern society as it helps shape the future by understanding the past. Through including elements of challenge, fun and exploring, we see that video game show a promising way of transmitting heritage. Specially, the use of online games which are accessible, pose and interesting way to transmit knowledge, create new communities and increase interest in industrial heritage.



Online:  
<https://andresgizem.itch.io/c5-zollverein-game>

**Figure 1:**  
Game Play Image

**Figure 2:**  
Main Menu UI

**Figure 3:**  
Game Tutorial

**Figure 4:**  
Historic Campaign Game Play

**Figure 5:**  
Game Dialog

## References

- [1]Boyan Bontchev. Serious Games for and as Cultural Heritage.
- [2]Koutsoudis, A., Arnaoutoglou, F., Pavlidis, G., Tsiafaki, D., and Chamzas, C., Eds. 2008. A Versatile Workflow for 3D Reconstructions and Modelling of Cultural Heritage Sites Based on Open Source Software.
- [3]López, G. A. and Cruz, D. C. 2021. Experiences of Knowledge Transfer on Industrial Heritage Using Games, Storytelling, and New Technologies. J. Comput. Cult. Herit. 14, 2, 1–26.
- [4]Robin Hunicke, Marc LeBlanc, Robert Zubek. 2004. MDA: A Formal Approach to Game Design and Game Research.
- [5]Sormann, M., Reitingner, B., Bauer, J., Klaus, A., and Karner, K. 2004. Fast and Detailed 3D Reconstruction of Cultural Heritage.

Figure 1



Figure 2



Figure 4



Figure 3

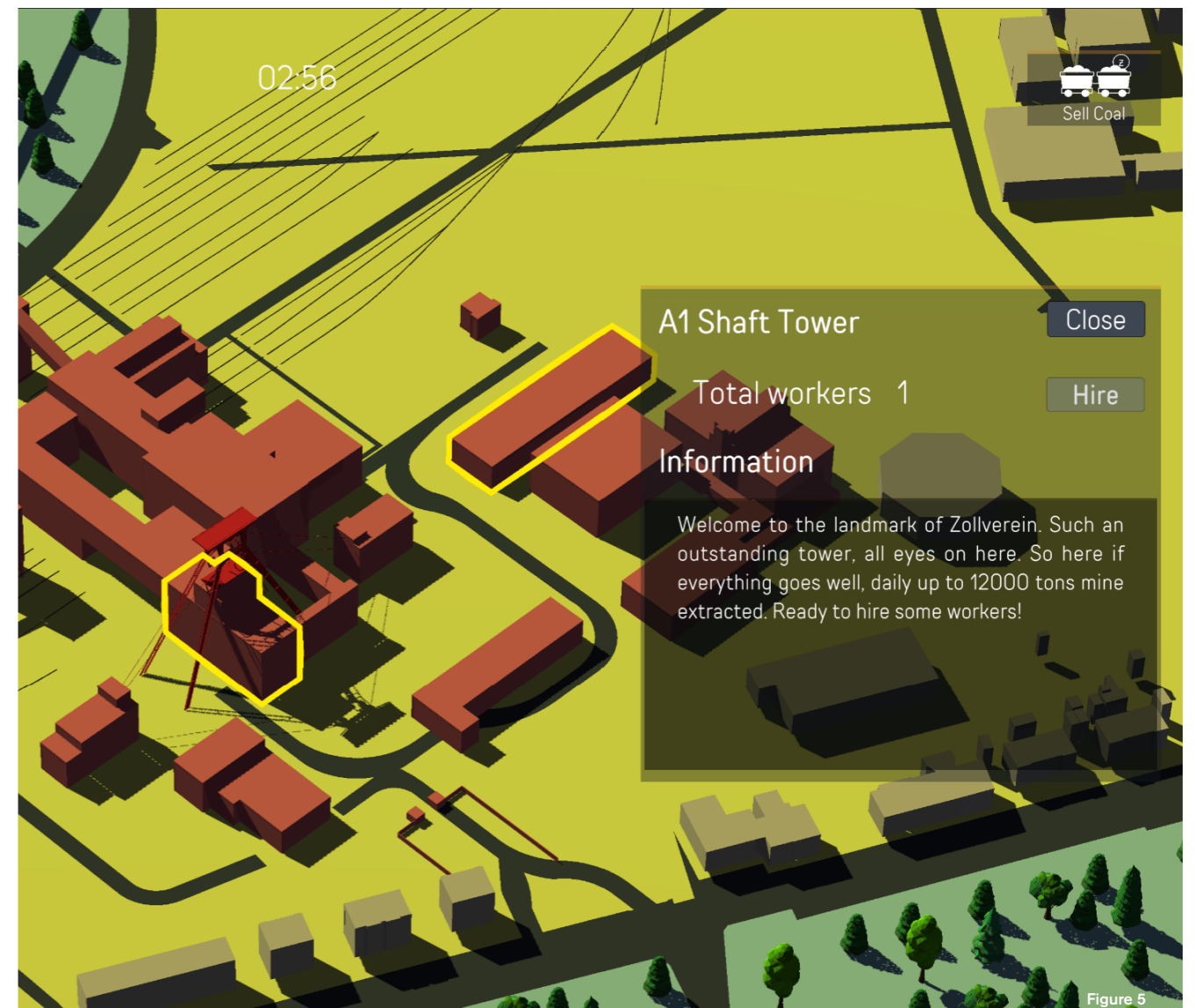

Figure 5

# MUMBAI TEXTILE MILLS, RE-USE & RECOGNITION

ASHLEY GROVER, GODO ZABUR SINGH, PUREE SRISUK &  
JUNAID NASIR

## Idea

In the 1880s, the British took over the fields beyond Mahalaxmi from local farmers and handed them over to private companies, with the stipulation that they run textile mills. With cheap labour in the form of migrants from Solanpur, Kohlapur and Ratnagiri, the new textile industry flourished.

During the last twenty years, this building type has been protected as a symbol of the historic value attached to the physical remains of the industrialization process. Our research aims to study Shakti Textile Mill and create a template to spread awareness about this aspect of British rule in India and its consequences on the local population through the modern means of virtual spaces. This unconventional approach is supported by the advances in the field of Virtual Reality and transition of various events, that were formerly confined to physical spaces, to virtual environments.

Our approach is to recreate the architecture of Shakti Mills virtually and juxtapose it with a surreal environment built on top of the remaining structure, as it exists today. The attempt is to breathe a new life into the efforts to preserve the heritage of an era which is fading from public consciousness with time.

## Methods and Tools

The approach here is to two-fold : 1.The first part is to create a digital replica of the original architecture of the Mills and provide a Virtual Reality tour of the model whereby a person can experience the scale of the buildings in a far more immersive manner than just looking at the drawings or the pictures. The architecture has been created as close to the original as possible with the aid of old pictures and drawings that could be found during the research process. 2.The second part of the process is to create a more fantastical and surreal Virtual Environment based on the remaining ruins of the Mills. The ruins were modelled in their current condition and juxtaposed with a completely different type of new geometry that is more aligned with the trends that we see in the current virtual spaces.

## Outlook

Due to the challenges posed by the COVID-19 pandemic, numerous new virtual avenues are coming up to tackle the need for people to connect when physical meetings are not possible. This new approach towards the virtual 're-use' hopes to make use of this up-and-coming space to bring attention towards these historical buildings that are scattered over the city of Mumbai, India and the world at large. With, these virtual spaces coming into existence, it would be possible for anyone to have an immersive experience of the function and architecture of these structures that are significant to the heritage of the country. Virtual museums and exhibitions, for example, could be created to demonstrate the working of machines in the factories or the living conditions of the workers in the Chawls. The ease-of-access and allure of this approach is conducive to pulling the attention of younger generations. The new spaces could also be used for virtual events like exhibitions, concerts and other such public events. A lot of work is needed to document the various other sites dotting the city and then fuse them with interesting additions that would enhance and complement the existing structures. This project is a start in that direction and would act as a template for further

## Online :

### 1. Youtube video (Scan QR code)

<https://youtu.be/ZGYBuxTms80>

### 2. VR (Sansar) model 1

<https://atlas.sansar.com/experiences/purees-3227/c5-mumbai-mill>

### 3. VR (Sansar) model 2

<https://atlas.sansar.com/experiences/purees-3227/1>



Figure 1

**Figure 1:**  
Perspective view from the front of the Virtual Model.

**Figure 2:**  
Perspective view from the side of the Virtual Model.

**Figure 3:**  
Perspective view of the model with original architecture

**Figure 4:**  
Real world picture of Shakti Mills

## References:

[1] Charles Correa : Master Plan for the Parel Mills Land Area (1996).

[2] Ignored Framed : Free, Democratic and Inclusive - Aditya Mandlik

[3] [https://www.reddit.com/r/AbandonedPorn/comments/9ru9zk/oc\\_a\\_closed\\_down\\_textile\\_mill\\_in\\_mumbai\\_india/](https://www.reddit.com/r/AbandonedPorn/comments/9ru9zk/oc_a_closed_down_textile_mill_in_mumbai_india/)

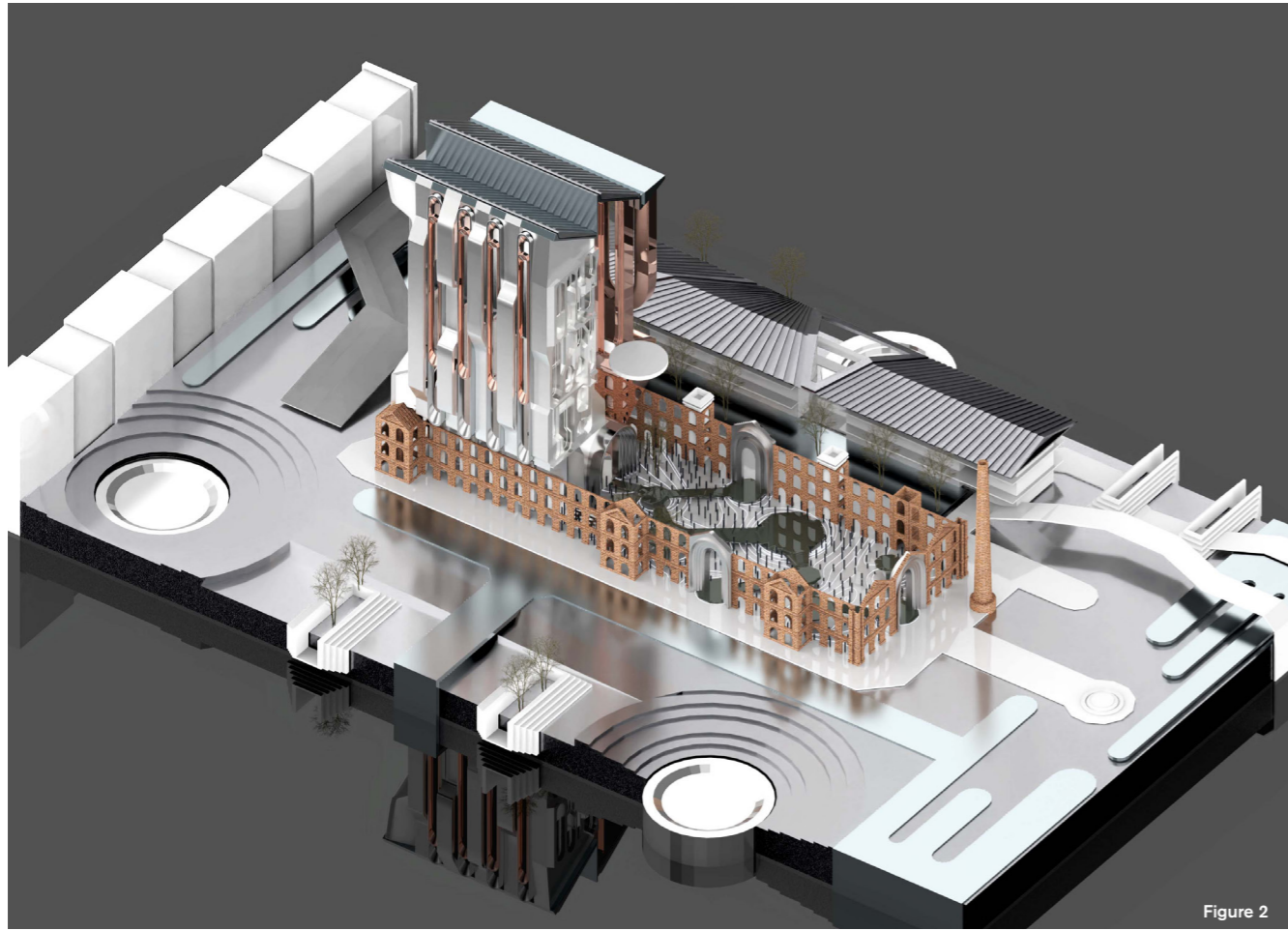

Figure 2

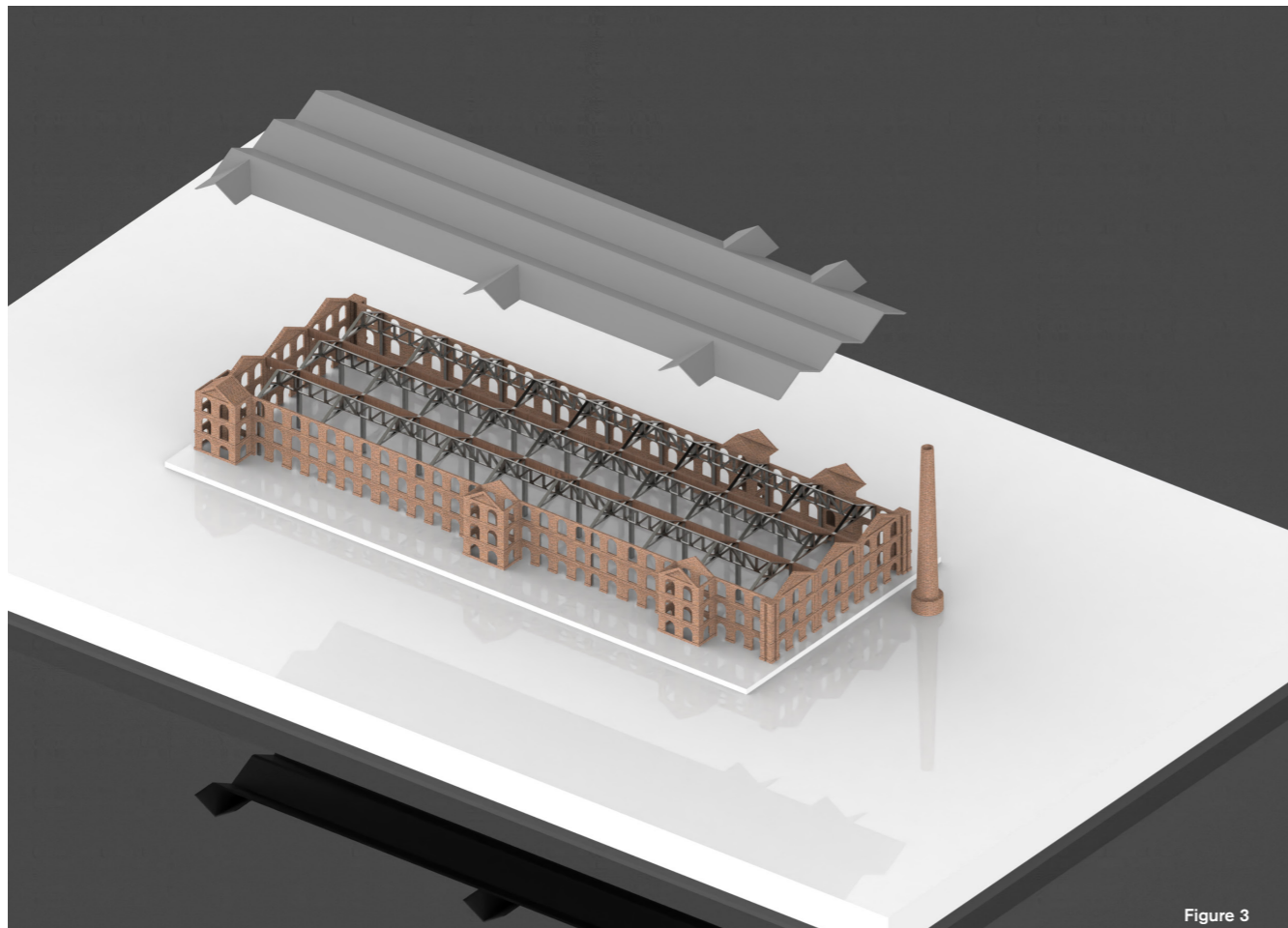

Figure 3



Figure 4

## AUTHOR'S BIOGRAPHIES

### MAHMOUD ABDELGHANY

Mahmoud Abdelghany graduated from Misr International University (Egypt) majoring in Architectural Engineering. He is a student in the Master of Integrated Design (MID) program with a specialization in Computational Design at TH OWL (Germany) & also working in Goldbeck (Germany) as a BIM specialist. After graduating he joined the design and visualization team at Masar for architectural services (Egypt) and after that LB Studio (Egypt) where he became a Team leader for the Architectural Design and Visualization team.

### BASIM AL-MOUSA

Basim Al-Mousa graduated from Jordan University of science and technology (Jordan) majoring in the science of architecture. He is a student in the Master of Integrated Design (MID) program with a specialization in façade at TH OWL (Germany). After graduating he joined the Morph-X design studio team (Jordan) as an architectural designer.

### ANDRES BUITRAGO

Andres Buitrago graduated from Universidad de Los Andes (Colombia) majoring in Architecture and Civil Engineering. He is a student in the Master of Integrated Design program with a specialization in Computational Design at TH OWL (Germany). After graduating he worked as a research engineer in a development company in his home country Colombia combining research, sustainability, and innovation. Currently, he is working as a developer in a 3D Modelling company in Germany.

### GIZEM DEMIRHAN

Gizem graduated from Eskisehir Osmangazi University (Turkey) majoring in Architecture. She is currently studying in the Master of Integrated Design (MID) program with a specialization in Computational Design from TH OWL (Germany). Prior to the master's, she worked in India as a junior architect participating in several international computations. And currently, she is working as a 3D Cad developer in Germany.

### ANICA DRAGUTINOVIC

Anica Dragutinovic, M.Arch., is a PhD Candidate at TU Delft (Netherlands) and at TH OWL (Germany). Her PhD research is focusing on the evaluation and transformation of modernist housing blocks in New Belgrade. She is a research assistant and coordinator of MID-programs at TH OWL (Germany) since 2016 and a MC member of the Cost Action MCMH (<http://mcmh.eu/>) since 2019. She obtained Master of Architecture in 2016 at the University of Belgrade, Faculty of Architecture (Serbia), and Bachelor of Architecture in 2014 at the same faculty. During her studies she was a student teaching assistant and had different internships on international level.

### RUTVI DEVANGBHAI VARIA

Rutvi Devangbhai Varia graduated from Nirma University (India) with major degree in Civil Engineering and minors in Corporate Finance. She is also a certified interior designer and entrepreneur, worked as an intern in Godrej and other civil projects. Currently pursuing Master of Integrated Design (MID) program with specialization in Facade Design at TH OWL (Germany) and worked as a research assistant under Prof. Daniel Arztmann, apart from attempting for a conference paper in bachelors.

### AHMAD ELNOSSERY

Ahmad Elnossery graduated from Misr International University (Egypt) majoring in Architecture with accreditation from

the University of Lucerne (Switzerland). He is a student in the Master of Integrated Design (MID) program with a specialization in Computational at TH OWL (Germany). Prior to the master's, he learned the 25 IBN principles of building biology in DIT (Germany) during a summer semester.

### PRAJITH GORENTLA

Prajith Gorentla has graduated in Mechanical Engineering in the year 2011 from JNTU University, Hyderabad (India). He is currently pursuing his thesis semester in Masters in Integrated Design program with specialization in Facade design at Technische Hochschule Ostwestfalen – Lippe, Detmold. Earlier this course, he worked with various building materials companies such as Fenesta, Hilti and Schueco India pvt. Ltd. He is passionate about travelling, meeting new people and all new Facade trends always fascinates him.

### ASHLEY GROVER

Ashley Grover graduated as an architect from Jamia Millia Islamia, New Delhi in 2018. During the five-year Bachelor of Architecture, he participated and won various National and International Architectural competitions. After the graduation, He worked as an Architect and Project lead at UnBox Design, New Delhi working in diverse scale of residential/commercial projects. He actively supported the studio's participation in competitions and non-commissioned projects as it provided him a compelling opportunity to explore his interest in Computational design. Currently, he is a student in the Master of Integrated Design (MID program) with specialization in Computational Design at TH-OWL Detmold, Germany.

### VITALIJ GÖTTMANN

Vitalij Göttmann has successfully completed an apprenticeship as an civil engineering draftsman. He also holds a Bachelor's degree in Architecture from TH OWL (Germany). Now he is studying for the Master of Integrated Architectural Design (MIAD) at TH OWL. During his studies, he worked at different architectural offices.

### SAHAR HEIDARI

Sahar Heidari has a bachelor's and master's degree in Architectural Engineering from Shomal University (Iran). She is currently studying in the Master of Integrated Design (MID) program with a specialization in Facade Design from TH OWL (Germany). She has more than five years of work experience in Iran as she is affiliated with the Engineering Association of Iran.

### PAUL HEISTERMANN

Paul Heistermann completed a bachelor's degree in architecture at TH OWL in Detmold and is currently a student in the Master of Integrated Architectural Design (MIAD) program at TH OWL where he also works as a student assistant for Prof. Dipl. Ing. Ernst Thevis.

### SHASHI KARMAKER

Shashi Karmaker graduated from the Ahsanullah University of Science and Technology (Bangladesh) majoring in Architecture. She is a student in the Master of Integrated Design (MID) program with a specialization in Facade Design at TH OWL (Germany) and doing part time job as working student at Verrotec GmbH (Mainz, Germany). While graduating she completed her internship in Tania Karim and N R Khan Associates (Bangladesh). Then after graduating she worked in another architectural company Drishik & Associates (Bangladesh) as junior architect for 1 year.

### FADI KHAMAM

Fadi Khamam holds a Bachelor of Arts from TH OWL University of Applied Sciences and Art (Germany), majoring architecture. During his Bachelor's studies, he was trained as energy consultant to understand the impact of the environment on buildings. His skills and interests lie in computational and urban design. He is currently studying in the Master of Integrated Design (MID) program with specialization in Computational Design at TH OWL (Germany). He is also working as a working student at Goldbeck GmbH (Germany) with a focus on BIM and automation in the AEC industry.

### MAXIMILIAN KIRCHHOFF

Maximilian Kirchhoff completed a state-certified construction engineering education. Then he began his practice-accompanying architecture studies, that he completed with a BDA award. He was also awarded the BDA Masters scholarship. He is currently studying in the Master of Integrated Architecture Design (MIAD) course at the TH OWL. Mr. Maximilian Kirchhoff is a member of the AKNW NRW.

### LEON KONSCHAKE

Leon Konschake studied architecture at TH OWL, ORT Montevideo in Uruguay and ISCTE Lisboa in Portugal. Currently he is studying in the master of integrated design program (MIAD) at TH OWL. Prior to the master's he is working at Studio Hocini Architekten since 2002 in his hometown Bielefeld.

### ANISSA SOFIA KRAIN

Anissa Sofia Krain graduated with a Bachelor of Arts in architecture from Jade University of Applied Sciences in Oldenburg (Germany). She is currently studying in the Master of Integrated Architectural Design (MIAD) program at TH OWL (Germany). Prior to her master's degree, she worked in various architecture and interior design firms in Hamburg and now works as a student trainee in an architecture firm in Bremen alongside her studies. Since her semester abroad in Bali (Indonesia) she has a special interest in Southeast Asian architecture.

### LEON LANDWEHR

Leon Landwehr studied architecture at TH OWL which he completed with a BDA award. Studying and living abroad in Copenhagen helped him to sharpen his architectural mindset. Currently he is studying in the master of integrated design program (MIAD) at TH OWL. Prior to the master's, he works for an architectural office in Bielefeld (Germany).

### CHARNELE LUKMAN

Charnele Lukman graduated from University Katolik Parahyangan majoring Architecture in July 2019 as a top-ten student of her batch. Continuing her study, she enrolls a Master Degree of Computational Design at Technische Hochschule Ostwestfalen-Lippe. For a year in Rakta Studio and Gao Architect she worked as an intern incorporated the diverseness of architectural designs. Concepting and synthesizing through assortments of projects ranging from residential, mix-used building, to governmental prototype project. By pursuing opportunities to emphasize computational design in architecture, structure and landscape development as her interest.

### VIONA MARX

Viona Marx graduated with a bachelor's degree in architecture at the TH OWL in Detmold in 2020. Right after that she continued studying there in the Master of integrated architectural design program and since she started her Masters degree, she is working in an architectural office in Lemgo.

### MAHAN MASHAYEKH

Mahan Mashayekh graduated from the Azad University CTB (Iran), majoring in Master of Architecture. He is a student in the Master of Integrated Design (MID) program specializing in Computational Design at TH OWL (Germany). Meanwhile studying, he learned to program and has been awarded 3rd place in Tehran's Robocup 2D soccer simulation competition. After graduation, he joined the Dabbagh architecture office and was a semi-finalist of the Mimar award architectural competition (Iran). With the idea of integrating programming knowledge with an architectural design process, he looks through improvements in the computational design research field.

### IRINA MIROSCHNITSCHENKO

Irina Miroshnitschenko completed her Bachelor of Science in architecture at Leibniz University in Hanover in 2018. After graduating, she worked for one year at f.u.n architekten in Herford. In 2019, she began her master's degree in architecture at TH OWL. Here she worked for a semester as a research assistant. She has been working in the construction department of the district of Lippe since 2020.

### ARDALAN MIRHADI

Ardalan Mirhadi has a bachelor's degree in Industrial Design from the Art University of Tehran (Iran). He is currently studying in the Master of Integrated Design (MID) program with a specialization in Computational Design from TH OWL (Germany) where he also works as a research assistant. Prior to the master's, He worked as a Freelance 3D designer in the Nargoon Architecture office (Iran).

### JESSICA MOLDENHAUER

Jessica Moldenhauer has successfully completed an apprenticeship as an architectural draftsman. She also holds a Bachelor's degree in Architecture from TH OWL (Germany). Now she is studying for the Master of Integrated Architectural Design (MIAD) at TH OWL. During her master's studies, she works in an office which is specialized in ReUse and schools.

### SOUMIA EL MOURABIT

Soumia El Mourabit has graduated from the American University in Dubai with a Bachelor's Degree in Architecture and a minor in Business Management. Also, she has a master's degree in Parametric Design in Architecture from the University Polytechnic of Catalunya located in Barcelona. Currently, she is a student in the Master of Integrated Design (MID) program with a specialization in Facade Design at TH-OWL (Germany), where she also works as a teaching assistant in the FABLAB. Prior to her masters, she worked in Dubai and Abu Dhabi with the position of internship then freelancing and graduate program.

### JUNAID NASIR

Junaid Nasir graduated from School of Architecture and Landscape Design, SMVDU (India). He is a student in the Master of Integrated Design (MID) program with specialization in Computational Design at TH OWL (Germany). He is also working as a student intern at Goldbeck, Bielefeld. After graduating, he worked in New Delhi for a few years before moving to Germany.

### BENEDICT NEISE

Benedict Neise has successfully completed an apprenticeship as a Carpenter. He also holds a Bachelor's degree in Architecture from TH OWL (Germany). Now he is studying for the Master of Integrated Architectural Design (MIAD) at TH OWL. During his master's studies, he works in an office which is specialized in ReUse and Ecological buildings.



**MOHAMAD NIZAR FANARI**

Mohamad Nizar Fanari graduated from the TH OWL (Germany) majoring in Architecture. He is a student in the Master of Integrated Design (MID) program with specialization in Computational Design at TH OWL where he also worked as a student assistant for 3.5 years. Along to his masters, he is working since August last year at Goldbeck Bielefeld as a working student in the BIM department.

**HANS-PETER NOLL**

Prof. Dr. Hans-Peter Noll graduated from Ruhr University Bochum with a degree in geography in 1984. In 1988, he received his doctorate (Dr. rer. nat.) and has been a lecturer at Ruhr University Bochum since then. Since 1989 he was appointed Managing Director at RAG Montan Immobilien GmbH, in Essen till 2017. At the same time, he was a board member of the Foundation for the Preservation of Industrial Monuments and Historical Culture, Dortmund from 2006 to 2017. 2017, Prof. Dr. Noll joined the Executive Board of Zollverein Foundation and will continue to shape the structural change of the region at the UNESCO World Heritage Site Zollverein in his new function. Since September 2020 he has been a member of the CDU in the association assembly of the Ruhr Regional Association (RVR) and deputy chairman of the Ruhr Parliament.

**UTA POTTGIESSER**

Uta Pottgiesser is Professor of Building Construction and Materials at TH OWL (Germany) since 2004 and Professor of Heritage & Technology at TU Delft (The Netherlands) since 2018. She holds a Diploma in Architecture from TU Berlin and a PhD from TU Dresden (both Germany). From 2017-19 she was appointed as Professor for Interior Architecture at the University of Antwerp (Belgium). She lectures and publishes internationally. She is Board Member of DOCOMOMO Germany since 2016 and was Chair of the DOCOMOMO International Specialist Committee on Technology (ISC/T) from 2016-2021. Since 2022 she serves as Chair of DOCOMOMO International.

**KURT C. REINHARDT**

Kurt C. Reinhardt, studied physics, philosophy and political science in Duisburg, Essen and Constance (Germany). Member of the Deutscher Werkbund. Freelance consultant for strategic corporate culture. For more than 25 years own research on the history and architecture of modernism, the Ruhr region and Zollverein. Teaching appointments at various universities in architecture, design and organizational development.

**THEODORA CHATZI RODOPOULOU**

Theodora Chatzi Rodopoulou is an architect, holding a PhD in cultural heritage studies and an MSc in Conservation and Reuse of Buildings from Delft University of Technology (TU-Delft). Her PhD research focused on the European industrial heritage reuse practice and won the Europa Nostra Award in the category Research in 2021. Theodora has worked as an architect in several firms and as a researcher in the Laboratory of Urban Environment of the NTUA, She has also worked as a lecturer, teaching Bachelor's and Master's courses in the Faculty of Architecture of TUDelft, the NTUA and the University of Thessaly.

**STEFAN RÖMER**

Stefan Römer studied medicine and geography at Ruhr University Bochum and graduated with a degree in geography in 2002. Since then he worked in various positions at Montan-Grundstücksgesellschaft mbH, Essen, later on RAG Montan Immobilien GmbH. RAG is concerned with brownfield redevelopment and inner urban development, planning and development of sites previously used for industrial purposes into

city districts, commercial and cultural sites. From 2010 he was head of communication and public affairs. Stefan Römer joined Zollverein Foundation as head of strategy, marketing and innovation in 2019.

**TINA SAFARHAMIDI**

Tina Safarhamidi has a bachelor's and master's degree in Architecture from Elmo Farhang University (Iran). She is currently studying in the Master of Integrated Design (MID) program with a specialization in Computational design from TH OWL (Germany). She also has three years of experience in planning and drafting in the architectural department of the Memarsazeh Caspian office (Iran).

**HYEONJI SEOL**

Hyeonji SEOL has a Bachelor's degree in Architecture from Dongguk University (South Korea). She is currently studying in the Master of Integrated Design (MID) program with a specialization in Facade Design from TH OWL (Germany). She is also working as a freelancer At VS-A KOREA, a branch of facade engineering offices, and Ublo inc., a window company. Prior to the master's, she worked at RUHA architects, an architectural office in Seoul, Korea.

**PUREE SRISUK**

Puree Srisuk graduated from KMITL School of Architecture, Art, and Design (Thailand). He is interested in the next paradigm of Architecture design, The possibility of computation design thinking. For this reason, brings He to study in the Master of Integrated Design (MID) program specializing in Computational Design at TH OWL (Germany).

**KEN TIETJEN**

Ken Tietjen is a student in the Master of Architectural Design (MIAD) program at the TH OWL in Detmold. During his studies he worked as a research assistant at the TH-OWL and is currently a working student at Goldbeck in Bielefeld. Before starting his master's degree, he completed his Bachelor of Arts in architecture at the TH-OWL and gained professional experience in an architectural office. He also studied business administration at the DBB School of Economics in Detmold and graduated as a state-certified business economist. For several years he worked as a web analyst in an e-commerce-driven company of the OTTO Group.

**CEM ÜNAL**

Cem has graduated in Architecture from Bahcesehir University in Istanbul (Turkey). He is currently pursuing his education in Master Integrated Design (MID) program with specialization in Facade Design from TH OWL (Germany). Prior to the master's, he had a chance to work in different fields of architecture, such as interior designing, urban planning, restoration and conservation and architecture in his home country, Turkey. He is passionate about learning new structural softwares and want to pursue career in technical part of the Facade.

**GOOD ZABUR SINGH UBHI**

Godo Zabur Singh has completed Bachelor's in Architecture from Guru Nanak Dev University, India in 2019. After graduation, he worked as a Junior Architect for 1 year at a Design Studio in India. Currently, he is a student in Master of Integrated Design (MID) program with specialization in Facade Design at TH OWL Germany where he also work as a research assistant. His work has been awarded and shortlisted among the top 30 designs in international competitions. His specific competencies are creating conceptual designs and technical drawings, handling 3d modeling and visualization for commercial, institutional, and housing projects.

**BUKET YOLERI**

Buket Yoleri completed her Bachelor of Science in architecture at Technische Hochschule OWL Detmold in 2019. After graduating, she began her master's degree in architecture at TH OWL. Besides she has been working in the Company Goldbeck since 2018.

## IMPRINT

Bibliography of the German National Library: The German National Library lists this publication in the German National Bibliography; detailed bibliographical information can be found at <http://dnb.ddb.de>.

Publisher	OWL University of Applied Sciences Detmold School of Architecture and Interior Architecture
Editors	Uta Pottgiesser, Anica Dragutinovic
Layout and Editing	Svenja-Christin Voss

The editors worked intensively to collect all copyrights of pictures/graphs. In the unforeseen case of using unauthorized pictures/graphs the editors ask to get in contact with them.

ISBN 978-3-939349-37-2  
DOI 10.25644/4d3d-2v96.

© 2022 TH OWL, Detmolder Schule für Architektur und Innenarchitektur

This work is licensed under a Creative Commons Attribution-ShareAlike 4.0 International License (CC BY-SA 4.0: <http://creativecommons.org/licenses/by-sa/4.0/legalcode>).