

# Universidad Autónoma del Estado de México

Facultad de ARTES

TÍTULO DEL MATERIAL PARA LA UA:

CeL Animation o Animación con Acetatos

Licenciatura en Arte Digital

UA: IMAGEN Y ANIMACIÓN DIGITAL

Elaboración: M. en E.V. MARIO ALBERTO BRACAMONTE OCAÑA

Fecha de elaboración: 2 de Septiembre 2015



# John Randolph Bray



# Hearl Hurd



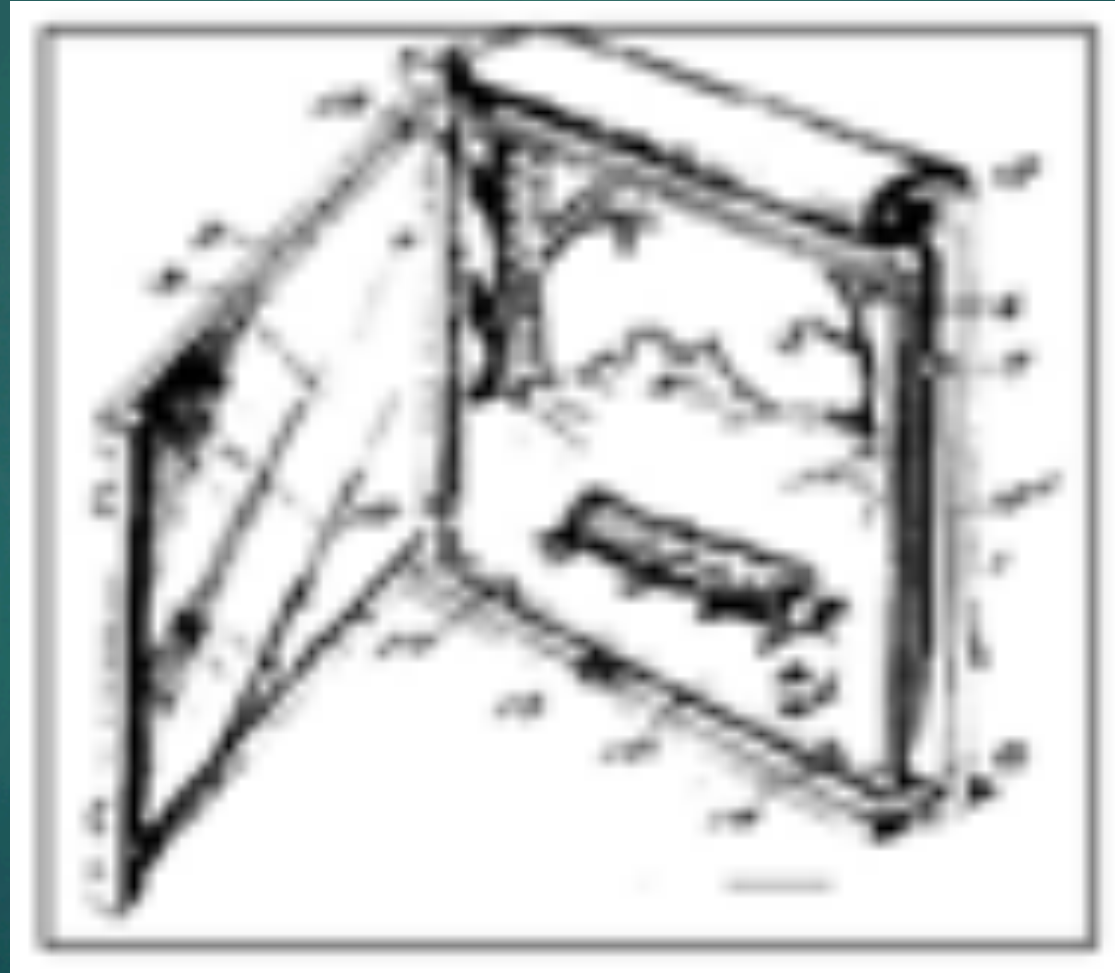

# Procesos y técnica.





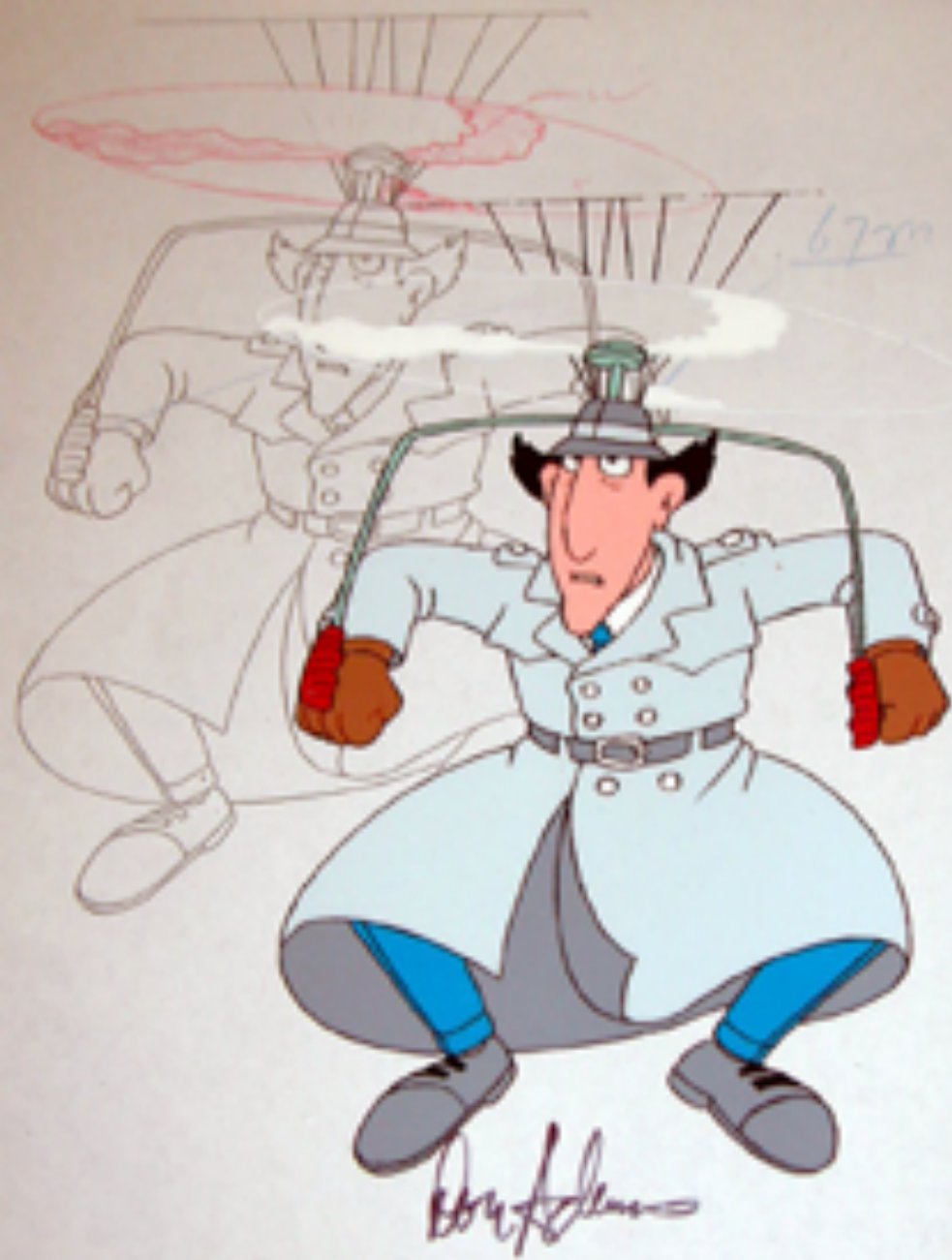



2-17

2-17 III 5





CAJA DE LUZ DE MADERA  
CON DISCO GIRATORIO, PEGBAR  
Y PERFORADORA PARA 3 ORIFICIOS REDONDOS





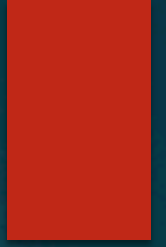

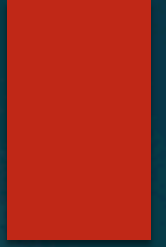

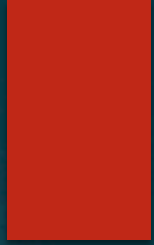



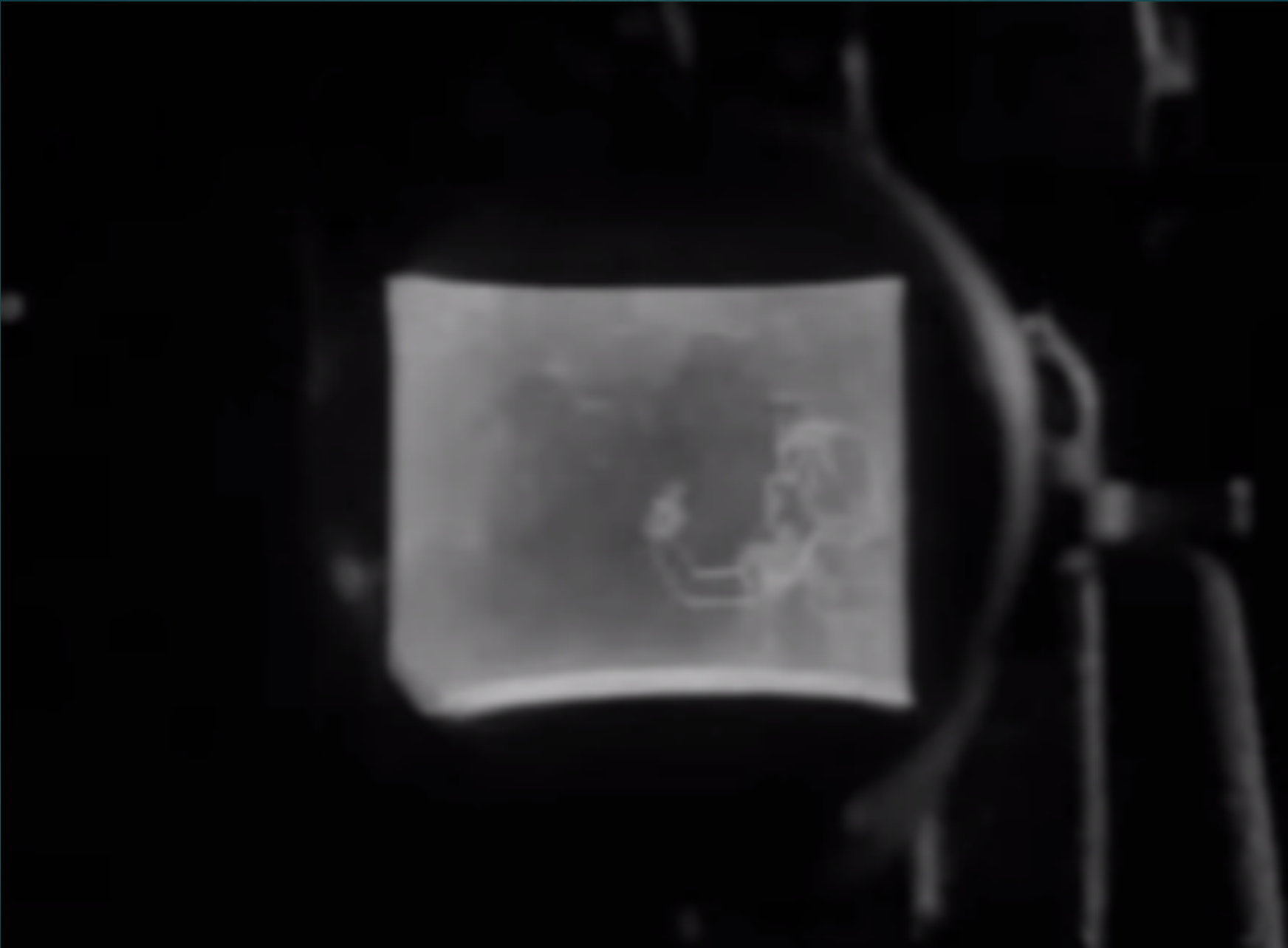



Every minute felt like an eternity.









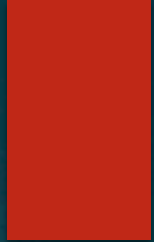

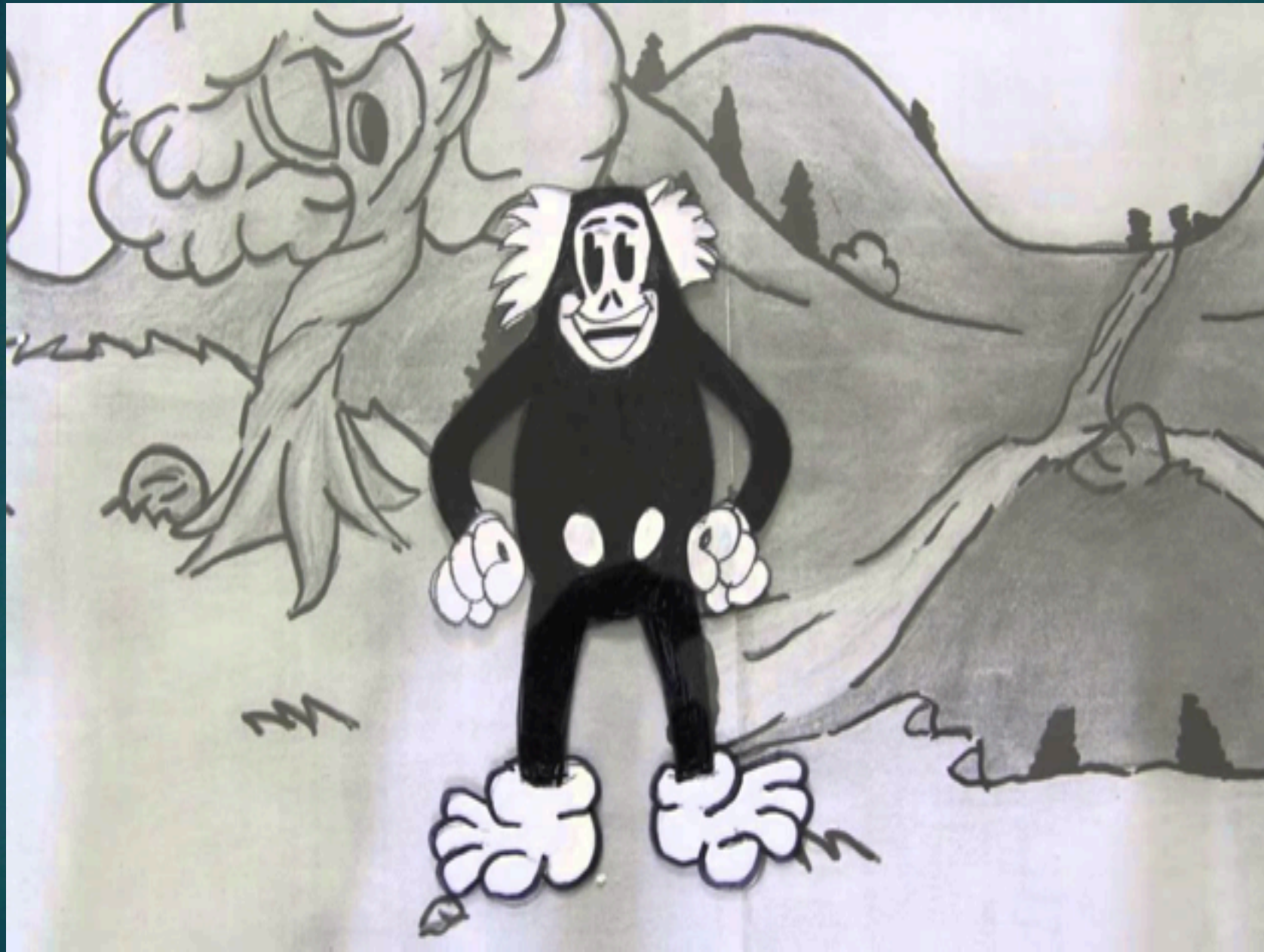







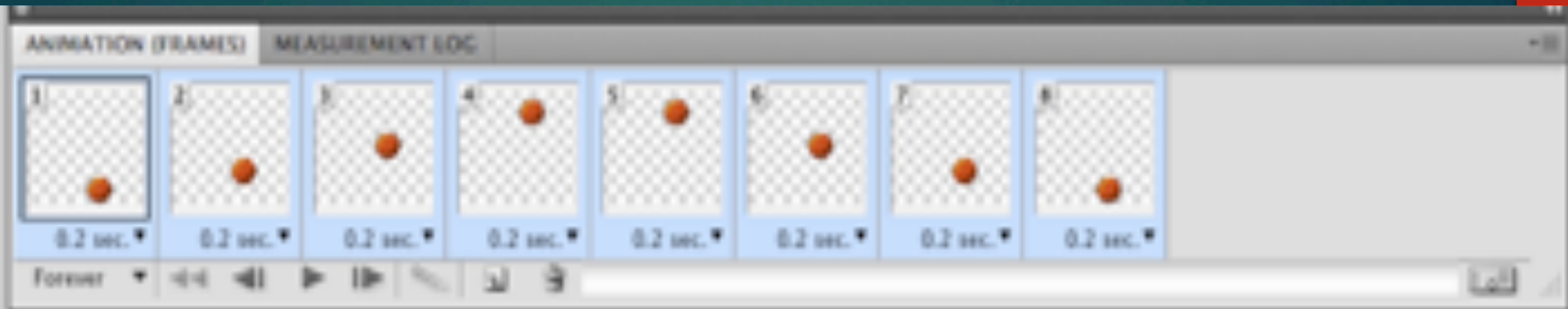



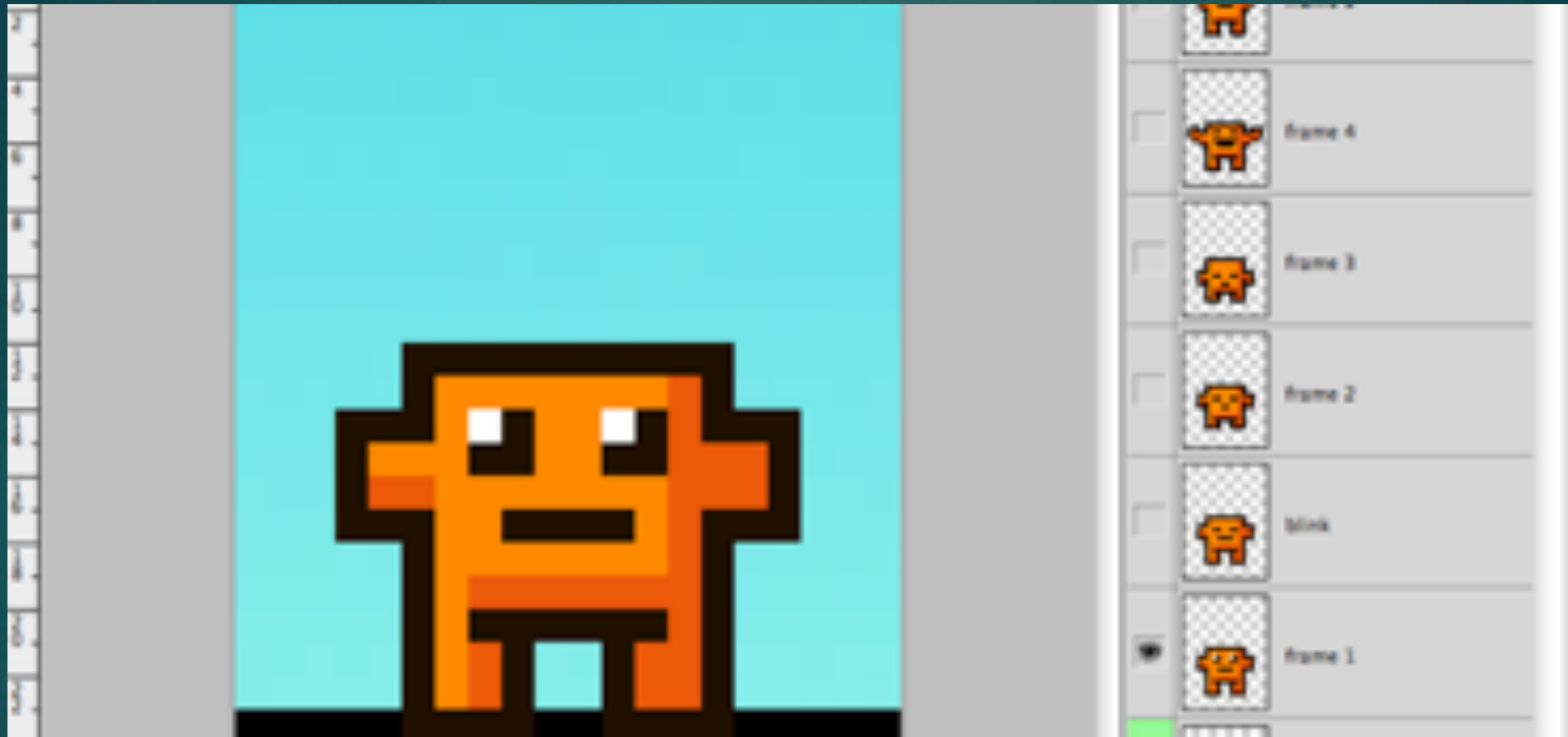





**TOON BOOM**

CELEBRATING  
**20**  
YEARS OF  
PASSION AND  
CREATIVITY



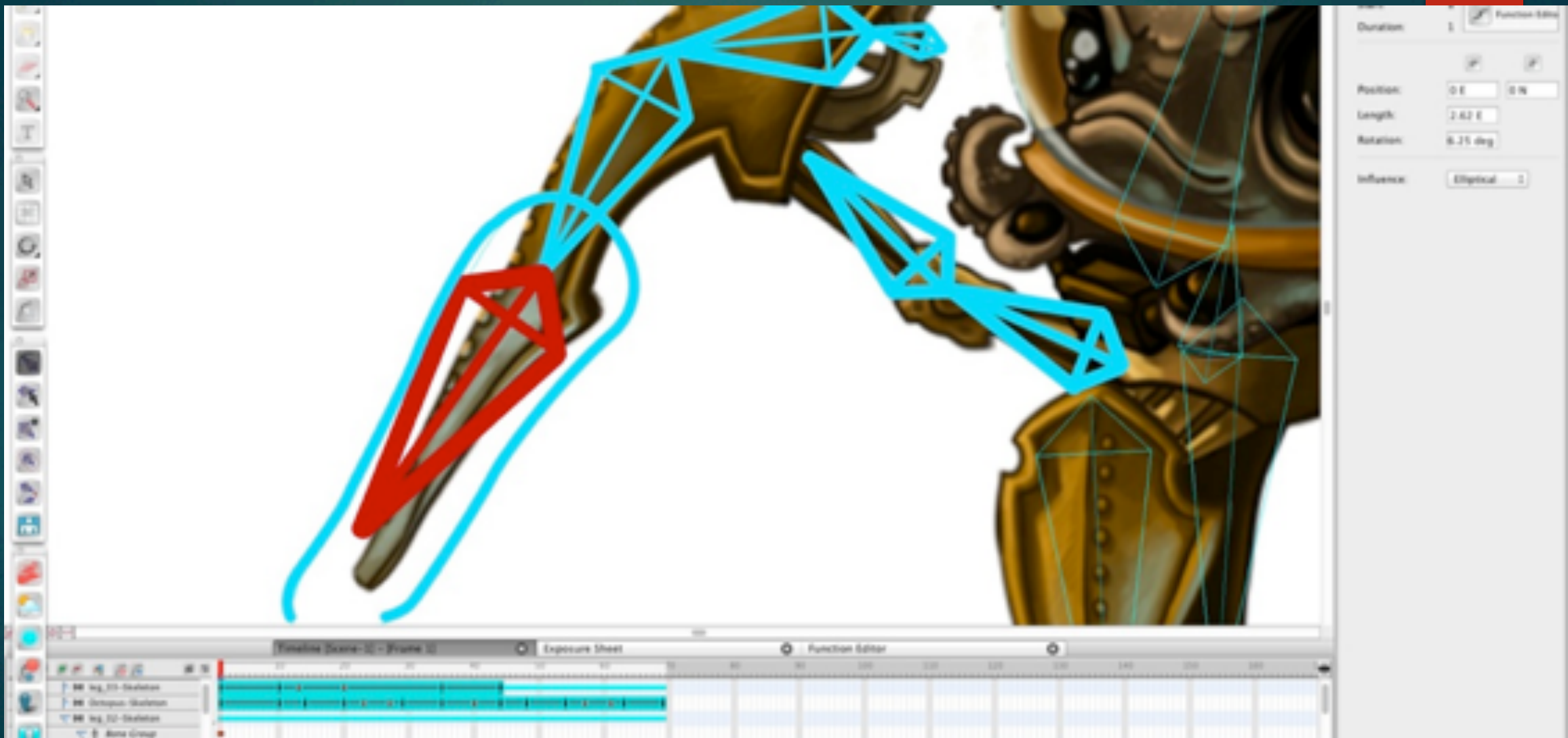





# Bibliografía

- ▶ **Alexander**, Kate. Sullivan Karen, Schumer, Gary. "Ideas of the animated Short. Finding and building stories". 2008, Edit. Focal Press. USA.
- ▶
- ▶ **Cardwell**, Ben. "Action! Cartooning, How to Havoc". 2004. Edit. Sterling Publishing CO. INC. USA.
- ▶
- ▶ **Patmore**. Chris. " The complete animation course. The principles, practice and techniques of successful animation". 2007. Edit. Quarto Publishing. USA.
- ▶
- ▶ **Selby**, Andrew. "Animation in Process". 2009. Edit. Laurence King Publishing Ltd. United Kingdom.
- ▶
- ▶ **Taylor**. Richard. "The encyclopedia of animation techniques". 2003. Edit. Quarto Publishing. USA.
- ▶
- ▶
- ▶ **White**, Tony. "How to make animated films". 2009, Edit. Focal Press. Oxford, USA.
- ▶
- ▶ **Webster**, Chris. "Animation. The mechanics of motion". 2005, Edit. Focal Press. USA.