

Available online at [www.sciencedirect.com](http://www.sciencedirect.com)**ScienceDirect**

Energy Procedia 74 (2015) 966 – 972

Energy

**Procedia**

International Conference on Technologies and Materials for Renewable Energy, Environment and Sustainability, TMREES15

## Direct components extraction of voltage in photovoltaic active filter connected in a perturbed electrical network (based on robust PLL algorithm)

Tadger Sid Ahmed<sup>a,\*</sup>, Habi Idir<sup>a</sup>, El Ganaoui Mohamed<sup>b</sup>, Angel Scipioni<sup>b</sup>

<sup>a</sup>Laboratory Electrification of Industrial Enterprises, University of Boumerdes, Boumerdes 35000, Algeria

<sup>b</sup>University of Lorraine, University Institute of Technology Henri Poincaré of Longwy (LERMAB & GREEN), France

---

### Abstract

The quality and performances of the compensation of harmonic currents depends strongly on the performances of the identification blocks of control side of the photovoltaic generators used as active filters. Then, the use of harmonics identification methods is not valid because the network voltage must be sinusoidal and balanced, which is not the case in practice.

Hence, to make the application of the identification methods of harmonic currents versatile and for any voltage form, we use the detection system of the fundamental component of the direct voltage.

In this paper, a comparison between the conventional method used for extracting the direct component of the network voltage which is based on the phase-locked loop (PLL) and the new approach based on a multivariable extraction filter. Finally, simulation results show that the proposed multivariable filter may better work even if the network voltage is (perturbed and unbalanced). Furthermore, this filter permits to generalize the use of identification methods for filtering the different perturbations of active and reactive current.

© 2015 Published by Elsevier Ltd. This is an open access article under the CC BY-NC-ND license (<http://creativecommons.org/licenses/by-nc-nd/4.0/>).

Peer-review under responsibility of the Euro-Mediterranean Institute for Sustainable Development (EUMISD)

**Keywords:** Photovoltaic system; Phase-locked loop; Multivariable filter; Power quality; Active power filters.

---

---

\* Corresponding author. Tel.: +213-663-106-200; fax: +213-24-798-300.

E-mail address: [sidahmed79dz@yahoo.fr](mailto:sidahmed79dz@yahoo.fr), [tadger@umbb.dz](mailto:tadger@umbb.dz)

## 1. Introduction

The electric energy quality and continuity of service constitute now days a major preoccupation of all energetic fields designers, network manager, supplier, producer and consumer.

However, the generalization of power electronics equipments, despite their multiple advantages (flexible function, excellent efficiency, high performances), they have yield to an increase of the perturbations at the electrical network level according to their current wave form and voltage which differ from the sinusoidal. For this reason, we call this equipments non-linear load [1].

The decrease of production quality, the premature wear out and brutal dysfunction, are the most known inherent effects after being exposed more or less long to the electrical perturbation, in particular, the harmonic perturbation which is considered as the major problems degrading the electrical energy quality [2]. Among the most known and efficient solutions, one find that the active filtering known by its advantages, essentially by the adaptation to load alteration and of electrical network [3-7]. However, the use of device such as active filter to control the harmonics propagation, will cannot affect adequate corrections if these noise are ill-identified and source if the voltage [8].

In this article, a multivariable extraction filter (MVF) is studied. Many voltage perturbations are applied to the new filter (MVF), and the conventional detection of the direct component of the voltage Phase Locked Loop (PLL). Simulation results are compared for two methods and interpreted [9-14].

### Nomenclature

MVF	Multivariable filter
PLL	Phase Locked Loop
THD	Total harmonic distortion

## 2. Direct extraction of the network voltage components

PLL is now commonly used in the control of active power filters [15-17]. From a theoretical point of view the concept is simple, but its implementation, especially in a disturbed environment (in the presence of harmonics, imbalance) is quite delicate. Indeed, some of its components require fine adjustments taking into account numerous parameters.

### 2.1. Structure of the conventional PLL

Figure 1 shows the entire structure of a conventional PLL phase [12]. It is split in a phase detector (the transformed coordinate), a low pass filter FPB (the control) and an integrator.

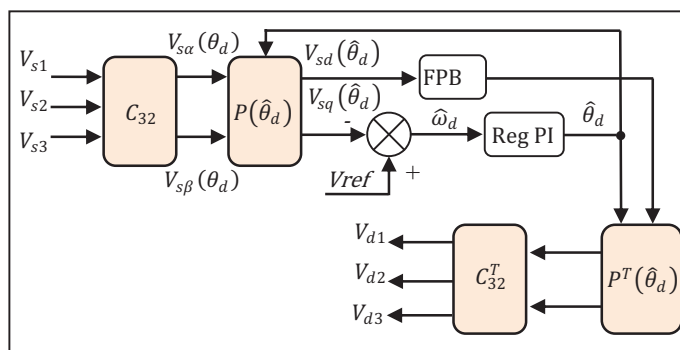

Fig. 1. General structure of conventional P.L.L.

Either the measured voltages on a three-phase network  $V_{s1}$ ,  $V_{s2}$  and  $V_{s3}$  subjected to a direct Concordia  $C_{32}$  transformation to work in a reference system  $\alpha\beta$  two dimensions. The voltages obtained  $V_{s\alpha}(\theta_d)$  and  $V_{s\beta}(\theta_d)$  (with  $\theta_d$  instantaneous phase is the actual forward voltage), are expressed in the DQ Park landmark by P rotation ( $\theta_d$ ), the angle of the rotation  $\theta_d$ , resulting from the integration of the estimate of the angular frequency  $\omega_d$  determined by the PI controller. In order for the P.L.L. to be closed, the rotation angle  $\theta_d$  estimated to be equal to the actual angle of the forward voltage  $\theta_d$ , this can be achieved when the value of  $V_{dref}$  is zero.

## 2.2. Identification algorithm

Let the measured voltages at the connection point of the parallel active filter sinusoidal and balanced, given by the following equations:

$$\begin{cases} V_{s1} = \sqrt{2}V \sin(\theta_d) \\ V_{s2} = \sqrt{2}V \sin(\theta_d - \frac{2\pi}{3}) \\ V_{s3} = \sqrt{2}V \sin(\theta_d + \frac{2\pi}{3}) \end{cases} \quad (1)$$

The calculation procedure after application of the transformation of Concordia and Park given by the following relationship [13]:

$$\begin{bmatrix} V_{sd} \\ V_{sq} \end{bmatrix} = \sqrt{3}V \begin{bmatrix} \sin(\theta_d - \hat{\theta}_d) \\ -\cos(\theta_d - \hat{\theta}_d) \end{bmatrix} \quad (2)$$

Where  $C_{32}$  Concordia is the matrix given by:

$$C_{32} = \sqrt{\frac{2}{3}} \begin{bmatrix} 1 & -\frac{1}{2} & -\frac{1}{2} \\ 0 & \frac{\sqrt{3}}{2} & -\frac{\sqrt{3}}{2} \end{bmatrix} \quad (3)$$

And the operator  $P$  symbol Park transformation, defined by:

$$p(\hat{\theta}_d) = \begin{bmatrix} \cos(\hat{\theta}_d) & \sin(\hat{\theta}_d) \\ -\sin(\hat{\theta}_d) & \cos(\hat{\theta}_d) \end{bmatrix} \quad (4)$$

The phase subsection will be achieved when  $\theta_d = \hat{\theta}_d$ . In this case, the actual of network voltage and the estimated angle are equal. We can write:

$$\begin{cases} V_{sd} = 0 \\ V_{sq} = -\sqrt{3}V_d \end{cases} \quad (5)$$

## 2.3. PLL behavior conventional versus disturbances

We will outline the conventional PLL unbalanced voltage system and other disturbed. For sinusoidal balanced case, the conventional PLL is useless.

Now, we present the P.L.L. to a unbalanced system sinusoidal voltages.

$$\begin{cases} V_{s1} = \sqrt{2}V \sin(\omega t) \\ V_{s2} = \sqrt{2}V \sin(1 + \beta) \sin(\omega t - \frac{2\pi}{3}) \\ V_{s3} = \sqrt{2}V(1 + \gamma) \sin(\omega t + \frac{2\pi}{3}) \end{cases} \quad (6)$$

With  $\gamma$  and  $\beta$  constants equal 0.3 and 0.5 respectively that occasion unbalance networks voltages.

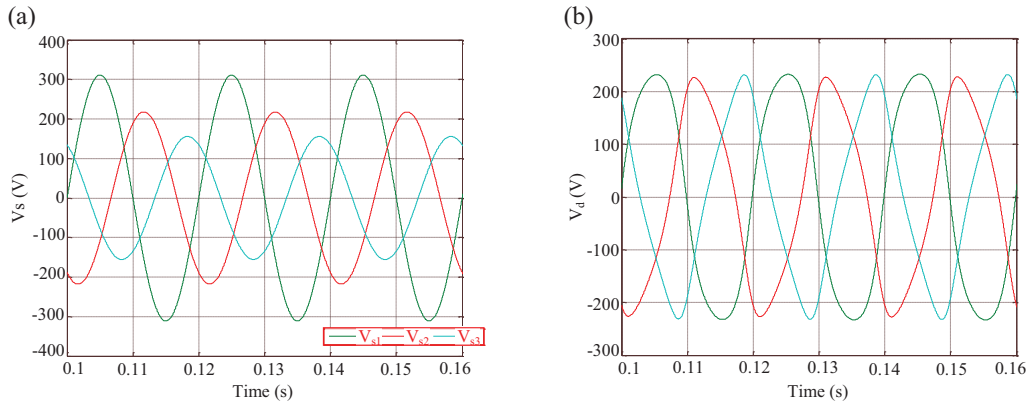

Fig. 2. (a) The unbalanced voltages of an electrical network; (b) Direct tensions extracted with the classical PLL.

In the unbalanced AC, figure 2.a presented above are influenced by the oscillatory disturbances networks voltages, as the THD (%) of these basic components is about 9.7%, and for the cosine and sine signals generated by PLL is about 9.81% and 10.54% respectively. Therefore, the technique of the P.L.L. conventional is not able to forward voltages generated from a unbalanced power system.

The last simulation designed for this PLL conventional is just executed under on a system that contains harmonic of order 5 and 7, to explore these performances (figure 2.b).

For the case of a supply voltage of the disturbed electric networks shown in figure 3.a, we consider the following system :

$$\begin{cases} V_{s1} = \sqrt{2} \sin(\omega t) + \frac{\sqrt{2}V}{5} \sin(5\omega t) + \frac{\sqrt{2}V}{7} \sin(7\omega t) \\ V_{s1} = \sqrt{2} \sin(\omega t - \frac{2\pi}{3}) + \frac{\sqrt{2}V}{5} \sin(5(\omega t - \frac{2\pi}{3})) + \frac{\sqrt{2}V}{7} \sin(7(\omega t - \frac{2\pi}{3})) \\ V_{s1} = \sqrt{2}V \sin(\omega t + \frac{2\pi}{3}) + \frac{\sqrt{2}V}{5} \sin(5(\omega t + \frac{2\pi}{3})) + \frac{\sqrt{2}V}{7} \sin(7(\omega t + \frac{2\pi}{3})) \end{cases} \quad (7)$$

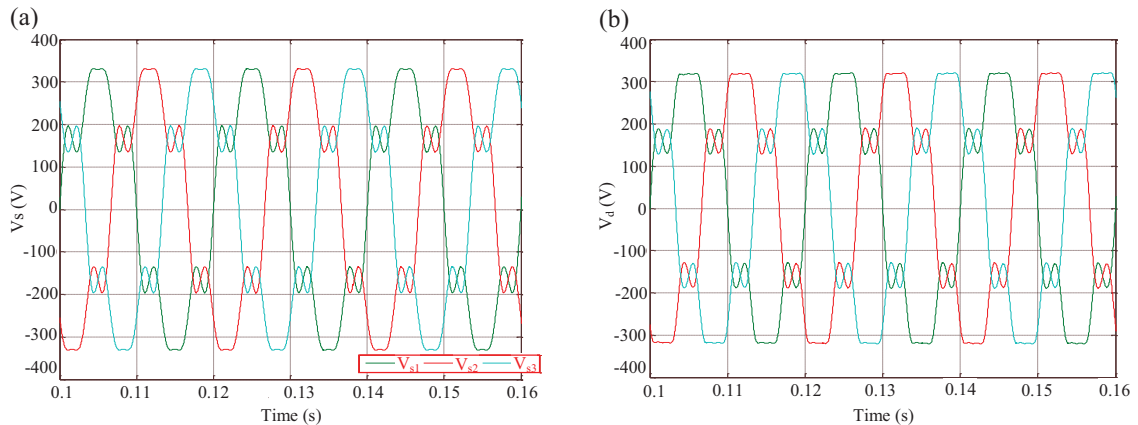

Fig. 3. (a) Disturbed supply voltages; (b) Direct tensions extracted with the conventional PLL.

In the disruption event, the figure 3.b presented is absolutely affected by the order of 5th and 7th harmonics by a THD (%) 28.79% of large order and the same for the cosine and sine signals generated by the PLL classic about 24.51% and 24.49% respectively.

As a result, the technique for extracting the fundamental component of the direct network voltage based on a PLL, is successful only when the system is reliable. But it harm by imbalance while the disruption of networks voltages. Consequently, it is sterile to generate direct components or trigonometric cosine and sine signals of good quality.

### 3. New approach to P.L.L.

To search other compromise between the dynamic behavior of conventional PLL and its insensitivity to various disturbances [9], a new approach to this technique will studied in this paragraph. This new approach is to introduce a multi variable filter between two quadratic pins of the conventional version of the PLL in order to overcome these disturbances behavioral problems.

We begin by exposing this new filter. Next, we'll explore this new approach to the PLL warder to examine its performance in with respect various disturbances.

#### 3.1. Multivariable filter

The above figures (2.b and 3.b) reflect the poverty of the conventional PLL against various disturbances. For this reason, a new type of extraction, appointed by FMV, was developed in the literature to improve the behavior of the ancient technique [13]. The following figure (4) presents the schematic diagram of the PLL including a multivariable filter.

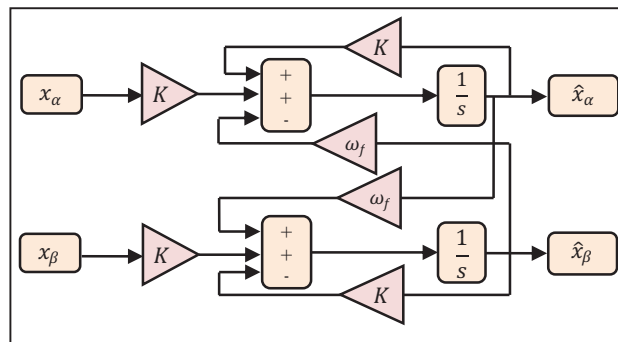

Fig. 4. Schematic diagram of the PLL including a multivariable filter.

The first advantage of this approach is its ease of implementation. Moreover, its basic principle is based on the extraction of the fundamental component signals directly as  $\alpha\beta$  axes.

Expressions link the components  $\hat{x}_{\alpha\beta}$  output of multivariable filter to come  $x_{\alpha\beta}$  components (x being the mains voltage) is as follows [9]:

$$\begin{aligned} \hat{X}_{\alpha} &= \frac{k}{s} [x_{\alpha}(S) - \hat{x}_{\alpha}(S)] - \frac{\omega}{s} x_{\beta}(S) \\ \hat{X}_{\beta} &= \frac{k}{s} [x_{\beta}(S) - \hat{x}_{\beta}(S)] + \frac{\omega}{s} x_{\alpha}(S) \end{aligned} \tag{8}$$

Different simulations are performed by the value of K that has been shown by [9-11]. This value of k, equals to 20, provides an entered phase with the output signal.

3.2. Behavior of the new P.L.L. which the various disturbances

In this section, we will outline the new PLL to three different systems of networks voltages implemented in three cases (figure 5 and figure 6). Finally simulation results will be explained and interpreted.

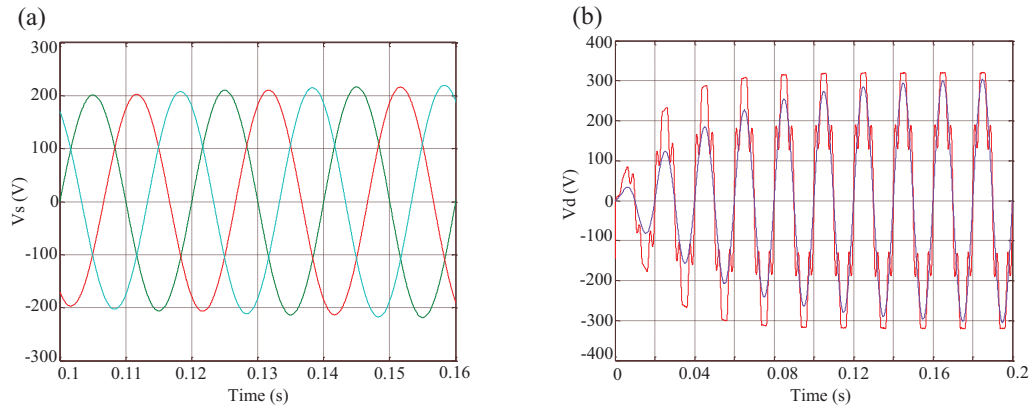

Fig. 5. (a) Direct tensions extracted with the new PLL; (b) Comparison between P.L.L. classic and the new approach (unbalanced cases).

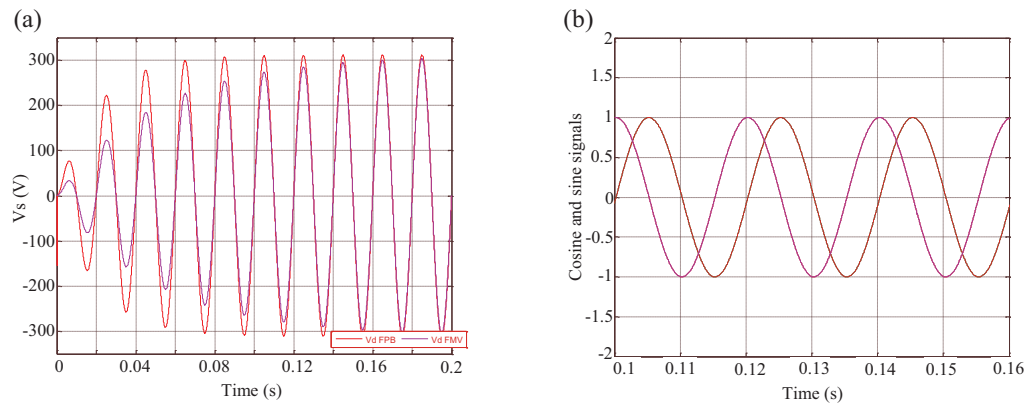

Fig. 6. (a) Comparison between P.L.L. classic and the new approach (perturbed cases); (b) The cosine and sine signals generated.

The simulation results of the figure 5.a shows that in the case of an unbalanced system, the new approach of the PLL has a good extraction of the fundamental voltage. A clear improvement is shown in figure 5.b. THD (%) of the direct component is 1.98% after it was 9.72% by PLL conventional. Nevertheless the response time remains the major drawback of this new approach.

The above simulation figure 6.a, clearly shows the performance of the PLL face a disturbed case are reformed to the property by a THD (%) 1.99% for direct fundamental component, according to what is was 24.02% in the conventional version. Figure 6.b shows the cosine and sine signals generated by the new PLL. The two signals are used in the control of photovoltaic inverters [19,20].

#### 4. Conclusion

In this article, we noted that the additional terms arising from the presence of disturbances in the voltages (imbalance or harmonic) had a negative impact on the various signals of conventional PLL outputs. To solve this problem we proposed a PLL that contains a multi-variable filter. His behavior towards these same disturbances was studied and implemented results were satisfactory.

#### References

- [1] Akagi H, Kanazawa Y, Nabae A. Generalized theory of the instantaneous reactive power in three-phase circuit. Proceeding International power electronics conference. Tokyo, Japan; p. 1375-1386, 1983.
- [2] Aredes M. A combined series and shunt active power filter. IEEE/KTH stockholm power tech conference, Sweden; 1995.p. 237-242.
- [3] Tadjer S A.Habi I.Nadji B. Harmonics Compensation System Based on Photovoltaic Generator. Italy ; December 2012. p. 1119-1122..
- [4] Zhang S. Research of marmonics measurement algorithm based on HHT. Energy Procedia 2012: 16: 1416–1423.
- [5] Tadjer S. Etude d'un système de compensation d'harmonique en utilisant un générateur photovoltaïque. Magister Memory – University M'Hamed Bougara (Boumerdes), December 2008.
- [6] Hadjidemetriou L, Kyriakides E and Blaabjerg F. A New Hybrid PLL for Interconnecting Renewable Energy Systems to the Grid, IEEE Transactions on industry applications, Vol. 49, No. 6, December 2013.p. 2709-2719.
- [7] Dauta I, Irwantoa M, Irwana YM, Gomesha N, Ahmada NS. Optimization of current total harmonic distortion on three level transformer less photovoltaic inverter. Energy Procedia 2012: 14: 1560-1565.
- [8] Hong Seok S. Control scheme for PWM converter and phase angle estimation algorithm under voltage unbalance and/or sag condition. Ph.D. in electronic and electrical engineering. South Korea, 2001.
- [9] Allali M A. A Contribution to the Study of Active Compensating Low-voltage Electrical, Doctoral thesis ULP – Strasbourg, 2002.
- [10] Pereira HA, Cupertino AF, Da C A, Ribeiro SG, Silva S R. Influence of PLL in Wind Parks Harmonic Emissions. IEEE PES conference on innovation smart grid. Sao Paulo; April 2013.p. 1 - 8.
- [11] Kyoung JL, Jong-Pil L, Tae JK, Dong WY, Soon MK, Dong Sik K, Hee J K. A novel active power filter for selective harmonic suppression based on a robust PLL Algorithm. 3rd IEEE International Symposium on Power Electronics for Distributed Generation Systems (PEDG) 2012.
- [12] Benhabib M C. Contribution à l'étude des différentes topologies et commandes des filtres actifs parallèles à structure tension : Modélisation, simulation et validation expérimentale de la commande. Doctoral thesis – Nancy, France, 2004.
- [13] Ouldabdeslam D. Technique neuromimétiques pour la commande dans les systems électriques: application au filtrage actif parallèle dans les réseaux électriques basse tension, Doctoral thesis – Haute Alsace, 2005.
- [14] Salem Nia A. Contribution à l'étude théorique et expérimentale d'un filtre actif parallèle à commandes analogique et numérique temps réel. Doctoral thesis – Nancy, France, 1996.
- [15] Kaura, Blasko V. Operation of a phase locked loop system under distorted utility conditions. IEEE Tran. on industry application; p. 58-63, 1997.
- [16] Wang Y F and Li Y W. Grid synchronization PLL based on cascaded delayed signal cancellation. IEEE Transactions on Power Electronics, 2011;26, no.7: p.1987-1997.
- [17] Kyoung JL, Jong PL. A novel active power filter for selective harmonic suppression based on a robust PLL Algorithm. IEEEExplorer; 2012. p. 416-422.
- [18] Lisheng S, Crow M L. A Novel PLL System Based on Adaptive Resonant Filter. Power Symposium. NAPS '08. 40th North American, Publisher: IEEE, Calgary, AB; Sept. 2008.p. 1- 8.
- [19] Tadjer S A, Habi I, Nadji B. Study and simulation of active filtering of harmonic by method of synchronous reference frame. Proceeding of the international conference on power Engineering, energy and electrical drives. Turkey, p. 1378 - 138. May 2013.
- [20] Baoqi L, Shanxu D, Bangyin L, Changsong C, Xiaolong J. Compound Synchronous Reference Frame PLL and Unbalance Control Strategy for Power Conditioning System in Weak Grids. Energy Conversion Congress and Exposition (ECCE), Raleigh, NC : IEEE ; Sept2012.p. 4538 - 4544.