

1-1-2023

Blockchain and sustainability disclosure: A scenario-based application for supply chains

Laura Corazza

Junru Zhang

Edith Cowan University, j.zhang@ecu.edu.au

Dilhani Kapu Arachchilage

Edith Cowan University, d.kapuarachchilage@ecu.edu.au

Simone Domenico Scagnelli

Edith Cowan University, s.scagnelli@ecu.edu.au

Follow this and additional works at: <https://ro.ecu.edu.au/ecuworks2022-2026>



Part of the [Operations and Supply Chain Management Commons](#)

10.3390/su15010571

Corazza, L., Zhang, J., Arachchilage, D. K., & Scagnelli, S. D. (2023). Blockchain and sustainability disclosure: A scenario-based application for supply chains. *Sustainability*, 15(1), Article 571. <https://doi.org/10.3390/su15010571>

This Journal Article is posted at Research Online.
<https://ro.ecu.edu.au/ecuworks2022-2026/1797>

Article

Blockchain and Sustainability Disclosure: A Scenario-Based Application for Supply Chains

Laura Corazza ¹, Junru Zhang ², Dilhani Kapu Arachchilage ² and Simone Domenico Scagnelli ^{2,*} ¹ Department of Management, University of Turin, 10124 Turin, Italy² School of Business and Law, Edith Cowan University, Joondalup 6026, Australia

* Correspondence: s.scagnelli@ecu.edu.au

Abstract: This paper presents the implications of blockchain technologies on sustainability reporting and disclosure, and specifically proposes blockchain use-cases as a possible solution for problems experienced in the field of supply chain carbon information. This study addresses how the reliability of supply chains' carbon-related information can become more transparent and reliable through a decentralized approach based on blockchain thinking (BT), issues that have been identified as a gap in the literature and in the practice. Scenario analysis and design science research (DSR) are used as a methodological driver to conceptualize over the nature of practical solutions using unified modeling language (UML) diagrams. The resulting use-case focuses on data retrieval in the supply chain. The paper also presents implications for the audit industry and their role in the assurance of such technological architecture implementations. The study is visionary as it offers a conceptualization based on scenario analysis. Developing a scenario enables researchers to depict a prospective situation, develop ability to solve future problems, and to back cast them in current policies, technologies, and actions.

Keywords: sustainability reporting; supply chains; blockchain



Citation: Corazza, L.; Zhang, J.; Arachchilage, D.K.; Scagnelli, S.D. Blockchain and Sustainability Disclosure: A Scenario-Based Application for Supply Chains. *Sustainability* **2023**, *15*, 571. <https://doi.org/10.3390/su15010571>

Academic Editors: Aijun Liu, Mingbao Cheng, Jianjun Wang and Wei Liu

Received: 24 November 2022

Revised: 20 December 2022

Accepted: 22 December 2022

Published: 29 December 2022



Copyright: © 2022 by the authors. Licensee MDPI, Basel, Switzerland. This article is an open access article distributed under the terms and conditions of the Creative Commons Attribution (CC BY) license (<https://creativecommons.org/licenses/by/4.0/>).

1. Introduction

This paper aims at answering some of the calls for further investigation on how innovative technologies are impacting sustainability practices and specifically how their implementation will benefit the reliability of supply chains related carbon data [1]. The changing landscape of management and decision making will include a post-human turn, in which intensive use of technologies will become not only the end or the means but also the agents of sustainability itself. In this paper, we addressed the case of sustainability disclosure, with a specific focus on sustainability reporting in the context of supply chains.

For the purpose of this study, it is worth better defining “reporting” from divulging and disclosing [2], while being aware that the literature [3] usually operationalizes such elements under the broader scope of sustainability accounting. Namely, we intend disclosure as the act of disclosing information over the sustainability of a company using different communication channels. “To disclose” is similar “to divulge”, even if divulging is, to further emphasize something [4]. Reporting is to be intended as the whole process of communicating the social and environmental activities of a particular company, over a period, and it is dedicated to its social interlocutors [5]. Thus, our paper refers to sustainability accounting as a synonym of non-financial accounting with the awareness that it may be further operationalized with its main three components of sustainability information (SI), sustainability disclosure (SD), and sustainability reporting (SR).

Why a study on blockchain technology might be relevant in the field of sustainability reporting and disclosure? Unfortunately, the discipline and the practice of sustainability reporting and disclosure are facing critical issues. The first issue is about manipulation of data, this happens often in a way they affect the reliability of sustainability reporting. Several scholars have

demonstrated how unsustainable corporations could adopt an instrumental and captious use of sustainability reporting making a maquillage of their performances [6–8]. Despite the role of audit and certification to guarantee that both data and reporting issues are safe from related errors, the use of sustainability reporting for fraudulent purposes is still a reality [9]. Cherry-picking, impression management, and camouflaging are the most used techniques to alter the communication of unsustainable behavior [7,10,11].

The second issue is about the materiality of the sustainability information provided [12–15]. Since the content of the report is based on material topics addressed both internally and externally to an organization, it is easy for a manager to manipulate such results, with the aim of disclosing, discussing, and reporting just the most positive and less risky topics about company performance [16,17]. Divulging critical information on sustainability will have value relevance [13,18]. For instance, examples of these disclosure issues relate to specific aspects of sustainability regarding the supply chain [19,20].

The third issue regards the global governance of sustainability movements and standards. Meaning all the forums, associations, roundtables, standards and guidelines that have the universal power to decide who is sustainable to who is not [21,22]. Since the value of such movements is to provide support and coordinated efforts towards sustainability, it can be that this has not been achieved yet. The so-called sustainable development goals have the power to remember that more needs to be done to support the sustainability of the planet, societies, and generations [23]. SDGs inspired our study to reflect on the fact that even the attention on sustainability reporting is more significant than in the past, the ability of sustainability disclosure to tell the “truth” cannot be guaranteed, nor through reporting neither by the attitude of signing agreements with NGOs.

All the three issues presented above have a common problem of trust and information asymmetry. As such, accounting literature has broadly discussed the impact of these broad business issue with different theoretical frameworks, for instance agency theory, legitimacy theory, institutional theory, stakeholder theory, signaling theory, and critical theory [24]. Moreover, Hahn and Kuhnen [24] point that more studies are needed regarding a true and fair view of sustainability reporting. We can affirm that blockchains deal with hyper democratization and trust issues, and in contrast with other scholars who investigated similar issues [25] our study aims at critically discussing the potential benefits of blockchain thinking (BT) for sustainability practices, and specifically on disclosure and reporting perspectives [26].

Blockchains are distributed ledgers shared by all participants in a network and rooted by a consensus protocol differently implemented with the aim of creating transactions that are democratically verified and validated [27]. Once approved, a transaction is officialized and added to a ledger, which can never be erased or modified without the majority consent. Thus, BT stems from reliable, transparent, and reliable technology [28]. Indeed, the widespread use of blockchains, as well as big-data, machine learning, and artificial intelligence, is changing the role of accountants, auditors, and financial statement preparers [29–34].

We are assisting with conceptualization and use-cases of BT within the areas of smart contracts, public sector, cybersecurity, healthcare, agriculture, tourism, transportation, etc. [35]; hence, we elaborate future scenarios on BT applications to sustainability reporting and disclosure. The increasing need in the trustworthiness of sustainability data is grounding the shift to more sustainable organizations [36,37]. Hence, the research question we want to address is—Could blockchains be helpful in solving SI trustworthiness issues? Answers will be provided through a qualitative and narrative scenario analysis [38] and design science research (DSR) checklist as guiding principles [39–41] aiming at offering practical though-provoking insights and applications of BT.

In summary the objectives of this study are:

- To identify the current issues in the preparation of sustainability reporting and disclosure by focusing on the case of supply chain carbon data and its reliability;

- To provide a possible solution to such issues by conceptually discussing and designing how a blockchain based system can support more transparency and assurance in the management of carbon-related data across suppliers.

The remainder of the paper is organized as follows: the next section will outline the context of blockchain applications in business and the implications regarding sustainability accounting. It will be followed by a methodology section addressing the details of how the study proposes future scenarios using design science research (DSR) and propositions section which illustrates the topics of research and providing the conceptualization of blockchains implementations. These will be discussed in the following section with the support of the extant literature. The final section concludes the study with specific remarks, implications from an industry and policymaking perspectives, as well as limitations and further avenues for research.

2. Literature Review

This section presents a literature review focusing on some of the business applications of blockchain technologies as well as the limitations currently facing in the sustainability reporting and disclosure practice. Broadening the scope of the recording of the mere financial transactions, we illustrate the potential benefit blockchain thinking (BT) can bring to sustainability management and accounting. Few mentions of the technical components of BT are useful to understand the power of its application in solving social accounting issues.

It is predicted that blockchain technology could enhance more than 40 million jobs by 2030 with the potential to add US\$ 1.76 trillion to the global economy [42]. The growing interest in this market confirmed by nearly \$1.4 billion of startup investments and preliminary decisions of the big four accounting firms to invest into the blockchain internal auditor sectors with the role of controller for the reliability of the technological infrastructure that supports all type of transactions [43,44]. Considering the value of sustainability management and disclosure for the market [45], \$17.1 trillion—or more than one in five dollars—are just the sustainable and responsible managed assets in the United States [46]. In Europe, we can account for more than €3.4 trillion of socially responsible assets, and the forecast suggests an exponential growth will occur in the next three years [47].

The disclosure and the reporting of sustainability data influence the decision-making process of stakeholders, and shareholders [48,49] we are living in an hyperconnected era, and the overabundance of data we can access to has the potential to distort business decisions [18]. For this reason, already in 2010, a study [50] expected that sustainability accounting research will continuously evolve and better enhance management decision making. In this direction, new technologies as artificial intelligence, machine learning, automation, remote control have been recognized as the next powerful tools able to change the management decision-making process in a business [51]. Multiple technologies exist to help SD and SR preparers, for instance ERPs, web-tools, and SaaS. They have all been designed to allow corporations of various size the ability to retrieve, account, assess, and benchmark their sustainability performance with other companies [52–54]. In general, the technology underlying these tools is based on Relational DataBase Management Systems (RDBMS), where data are stocked using SQL (structured query language) or NonSQL statements. In all these cases, multiple copies of the data are required to be elaborated through logs and locks to create a benchmark. These RDBMS are for the most part centralized and unencrypted.

First introduced by Satoshi Nakamoto in 2008, as giving birth to cryptocurrencies, blockchains have been evolving and adapting to become a technologic panacea to all those situations requiring a move from centralized storage of transactions to a decentralized consensus mechanism (DCM), avoiding the use of third-party assurance [55]. In its business declination, blockchains are comprised of digital infrastructures, deployment modes, and implementations [56,57]. Digital infrastructures consist of peer-to-peer networks, where each node does not depend on any central node. Deployment modes regard how information runs through DCM, which is responsible for data logging and simultaneously solving a Byzantine's general problem using a cryptographic puzzle to safeguard the permanent

storage of a block [58]. A unique string called hash identifies each block in a blockchain. Implementations define how a blockchain interacts within existing business processes.

Several configurations of blockchains exist from private to public, and different degrees of freedom in DCM have been designed to allow a sort of customization of blockchain technologies as well [59]. That is the case of proof-of-work (PoW) or proof-of-Stake (PoS); wherein PoW miners solve a computing-intensive task to conclude a block. On the contrary, in PoS, “forgers” are rewarded for verifying transactions [60].

In summary, blockchain operates through a distributable database, sharing data between nodes and without any intermediaries. In fact, they are called peer-to-peer, where each node stores and forwards information to other nodes. Usually, every transaction is visible by anyone, but users can decide to be anonymous or to provide proof of their identity. All data are stored everywhere, and they are irreversible thanks to computational algorithms that require computational power to safeguard any possible attacks. However, even in blockchains, there could be security breaches that usually drives the significant portion of computer power to revise a block [61].

The blockchain was initially designed to create tamper-proof databases and to divert information from “agent-based” control. Currently, BT business applications are less anarchic and more business solution-oriented [27]. Researchers and companies are testing the application of the underlying technology in different contexts, such as public sector, law enforcement, supply chain management, cybersecurity, healthcare, agriculture, tourism, transportation, etc. For instance, BT can improve supply chain management in cross-borders transactions linked to e-commerce application, because it can guarantee a more transparent approach and limit the number of intermediaries involved [62]. Furthermore, given the technical nature of the blockchain itself, even accounting operations can benefit from this approach: “Some scholars have argued that the invention of double-entry bookkeeping enabled the rise of capitalism and the nation-state. This new digital ledger of economic transactions can be programmed to record virtually everything of value and importance to humankind” [63] (p. 7).

For instance, the blockchain use in accounting and business can be fruitful in the field of audit services because the audit profession is closely linked to investigating deceptions and frauds that blockchains can possibly help to avoid using immutable and transparent records of transactions [31,57,64]. While the audit profession is benefitting from new technological advancement, prospective studies on how accounting and accountability might change in the future are needed [65–67]. Consistent with Tapscott and Tapscott [63] (p. 25), everything that can be expressed and transformed into their codes may be a potential use of blockchains, from storing information of contractual agreements, to record financial transactions as well as recording the subjects involved in the procurement, production, and sale of goods and services from an integrated supply chain perspective. As most of the sustainability reporting standards have started coding their required KPIs and measures, then, it is possible to affirm that also SR will be subject in the future of somewhat blockchain intervention. For instance, there is proof of coding SI in all the work related to a technology advancement such as XBRL [68].

Academics and practitioners envisage a vast space for BT application, especially in the sustainability space, and most of it is still unexplored [69]. Specifically, Zhang et al. [69] present a potential use of the blockchain in SD, stating how ERPs nowadays contain a lot of detailed information on sustainability, which if disclosed, would allow stakeholders to evaluate, among other issues, the quality of such non-financial performance. Cockroft and Russell [31] forecast that SR will be particularly significant areas of future research for technological advancement. Accordingly, Bakarich et al. [25] find that blockchain is well-positioned to provide reliable tracking and custodial support of sustainability data and information, including the reporting of greenhouse gas emissions, conflict mineral disclosure, and products and service procurement.

Furthermore, the disruption caused on global supply chains by the recent COVID-19 pandemic as well as the instability caused by the war in Ukraine show that additional infor-

mation and transparency regarding the stock and availability of resources at a worldwide level, is needed to solve the resulting supply/demand shocks.

We believe that there is a timely need of producing more artifacts that can support the actual implementation of the blockchain. As such, the paper presents possible scenarios and applications of BT for in the sustainability context, with a specific focus on supply chains and procurement. As many start-ups are working in the field of blockchain, we believe that our work can be useful for all the subjects interested in this topic.

3. Methodology

This study was based on scenario development and analysis. We considered a future scenario as the intent of formulating and drawing coherent and plausible stories, using a qualitative and quantitative method, about a what-if situation involving human and environmental systems [38]. Usually, it is aimed to imagine a desirable future followed by backcasting, or, in other words, identifying those leverage factors (policies and actions) that may drive the change towards specific goals. In scenario analysis, the first step was a definition of problem boundaries, a characterization of current conditions and processes driving change, identification of critical uncertainties and assumptions on how they are resolved, and images of the future. Scenario analysis is an evolving concept in applying critique on uncertain events that might shape that scenario.

Additionally, a design science research (DSR) conceptual approach has been used to develop the findings in applying and proposing the adoption of blockchain to sustainability reporting and disclosure. Applying DSR requires six significant activities, namely: DSR1, problem identification and motivation; DSR2, define the objectives of a solution; DSR3, the design and development of an artifact that meets (some of) the solution objectives; DSR4, demonstration of the solution; DSR5, evaluation of the solution; DSR6, communication of the problem and the solution (for instance a research article, a patent, etc.) [39–41]. We limit our study to the first three DSR steps, as our study proposes scenarios without arguing that the solution offered is the best available solution, neither we evaluate the effectiveness of the solution proposed.

We focus our study on three specific issues recognized as timely and relevant for more accountability and sustainable practices [39,70–72]:

1. The attitude of manipulating sustainability information (despite audit and certifications) that in turn affect the reliability of reporting (cherry-picking, impression management, and camouflaging);
2. The attitude of altering the content of sustainability reporting, i.e., influencing the materiality process;
3. The truth revealed through sustainability disclosure and reporting may differ from the real underlying actions and practice (governance of the commitment towards sustainability).

The following discusses the first two propositions in the DSR process, whereas the subsequent use-case diagrams are used for the third one. A use-case diagram was adopted in software engineering, through UML (universal modeling language), to describe any fundamental steps of a system, regarding a scenario of a system use [73–76]. A use-case represents an interaction between a user and the system, the user (actor) interacts with the system through arches that, in turn, show: interactions between actor and use-case; links between use-cases; extension or generalization of use-cases [77].

Scholars are advancing concerns on the use of UML for blockchain-oriented systems as they may require specialized graphics models for representation [78]. Even though UML is still valid, and software engineering scholars are using it to diagram blockchain use-case [79]. Hence, we adopt use-case as an exploratory strategy to elaborate scenarios [80].

Our methodology approach is summarized in the diagram included in Figure 1.

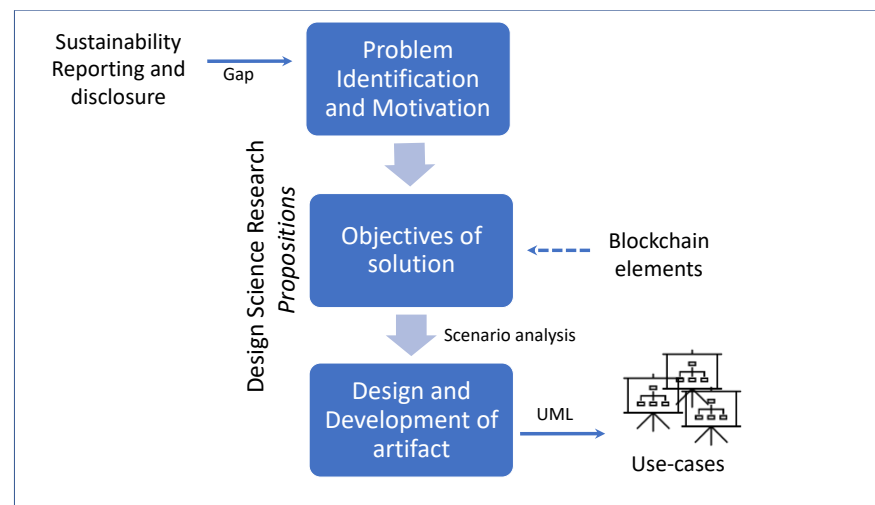

Figure 1. Methodology adopted in the study.

4. Results and Discussion

4.1. DSR Propositions

This sub-section presents a discussion of specific issues affecting sustainability disclosure and reporting from a research design perspective. The narrative is systematized, offering a depiction of the problem and the objective of the solution. The next section presents and discusses the solutions.

4.1.1. Problem Description: The Attitude of Manipulating Sustainability Data That in Turn Affect the Reliability of Sustainability Reporting

The trustworthiness of sustainability data represents our first concern. The answer given up to now is that external assurance and audit should guarantee with truthfulness and fairness the reliability of the content of a sustainability report itself. Usually, assurance is external and conducted by third parties [81]. This assurance can be cautious and limited due to the pressure exerted by management control [82]. As demonstrated by Junior et al. [83], the transparency of the assurance process influences the way through which the assurance assumes a relevant role [83]. More than a single subject needs to be involved, as the presence of networks or committees emphasizes the credibility of the process of assurance [9,84,85].

4.1.2. Solution Design

Is this in line with blockchain studies? The answer is yes, as DCM is studied to deal with the same problem. Blockchain technologies guarantee that data will be unmanipulated because anyone in the network has the power to act alone or make changes without leaving trace/record. Blockchain will influence the ability of SR to emancipate by collecting contributory data from the bottom of the organizational hierarchy up to the top as well as alongside supply chains from all the actors involved.

4.1.3. Application

Coherent with the literature, this study presents the case of sustainability data to be gathered throughout the supply chain. It is the frequent practice among multinational corporations to consolidate sustainability data following the same consolidation perimeter used for financial data. To avoid control and to incur additional costs associated with down-stream sustainability reporting, corporations demand their first tiers to provide the data, and it is up to them to verify the reliability of the content provided [19]. SR preparers request such data through a hierarchical process encompassing an extended group of legal entities. For instance, in the case of injury rates, CO₂ emissions, or fines for non-compliance

with laws and regulations, the first tiers, as well as, the “parent company” all have a vested interest to take that indicator as low as they can [86].

A blockchain-based solution can help organizations to identify a problem linked to their suppliers and sub-suppliers before it shows up. For instance, through the use of smart contracts, tracking the logistics of each phase of the production process, from the first raw material producer to the final customer, could be feasible, especially when integrating RFID and GPS tracking. With such a process, the computation and tracking of CO₂ emissions will be easier and less dependent by estimates as it is now.

4.2. Discussion

Supply chains are becoming a fertile terrain for blockchains implementation, as they deal with the exchange of goods, ownership rights, and underlying financial transactions. In SR, corporations usually ask their first tiers to report their sustainability efforts while they down-stream that request to their sub-suppliers. All the actors involved in the editing process have an interest in publishing the least possible amount of negative information and related indicators, and vice versa, so to release as much as possible positive information. Despite the presence of possible “assurers”, there is the risk of data manipulation and camouflaging, as it is widely demonstrated in the literature [83,85].

Figure 2 shows the current state-of-the-art process of SR with evidence of the down-stream flow of information requested.

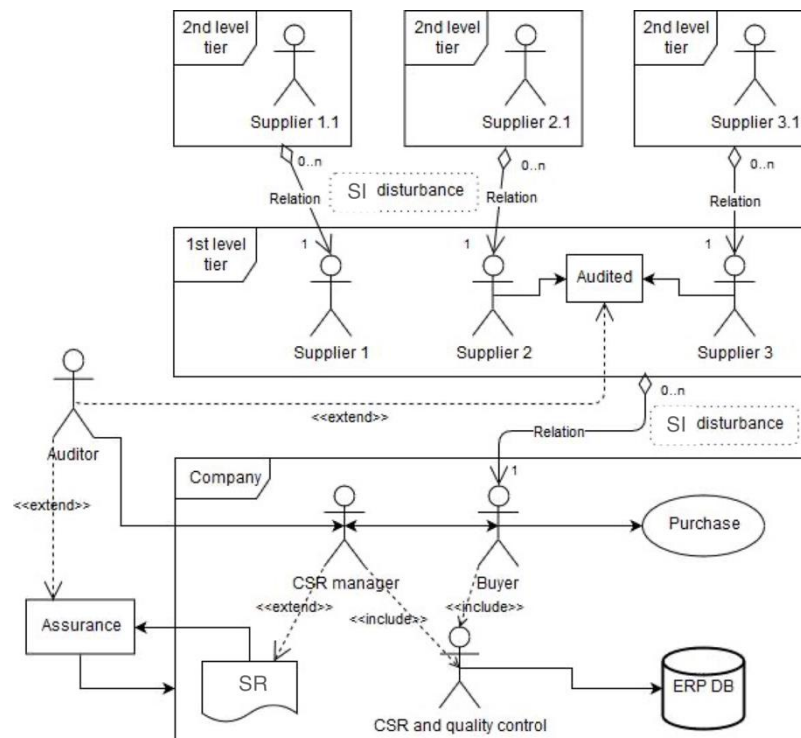

Figure 2. Use-case diagram of a hierarchical request of SI in the supply chain.

In Figure 2, a company asks first level suppliers (or tier 1) to provide data on SI that in turn should ask its supply chain from 0..n actors. Actors reply providing data that could be manipulated by the receiver according to its convenience (SI disturbance intended as an event). Inside the company, the SI preparer, hypothetically the CSR manager, relating to the procurement function, requests some audits along the supply chain. Data coming from the auditor are merged with the data required, and the documental output is the SR that is assured as well. Data are stored on an owned ERP database, and access is not allowed neither to the auditor, that guarantees the process not the data nor to the suppliers and

sub-suppliers. On the contrary, Figure 2 shows how blockchain impacts the process of gathering data inside supply chains.

In Figure 3, a company publishes a sustainability report entirely based on BT-obtained information. The company asks its first level tiers to provide data through the blockchain. The data cannot be modified or erased without the consent of all the nodes. The company cannot inhibit the content or the raw data and eventually, it could influence the disclosure of the entire information contained, avoiding the possibility to select what to report, by the results obtained. In this new scenario, the auditor acts as a technology supervisor to assure that the technical architecture is not modified or manipulated by the actors. This use-case also considers the possibility that all the data stored in the owned DB might be converged and come from blockchains.

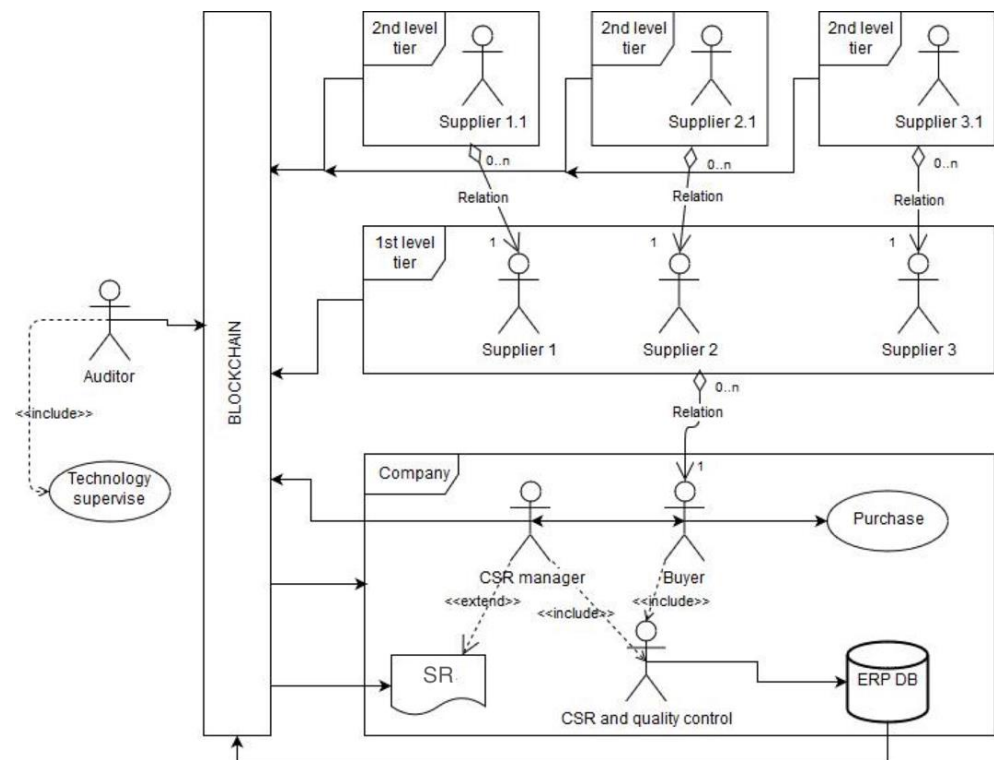

Figure 3. Use-case diagram of SR based on BT.

5. Conclusions

This paper provides a conceptual discussion based on designing future scenarios that apply blockchain thinking (BT) to sustainability reporting and disclosure. Scholars across sustainability management and social increasingly call for an emancipatory change that give stakeholders more transparency and reliability, possibly, sustainability reporting possibly represents a solution when information asymmetry is overcome by a balanced involvement of all parties in the disclosure process. The study is material as there is a substantial lack of research and empirical evidence in the field of blockchain applied to sustainability reporting.

First, the study presented some limitations and concerns emerging from years of sustainability reporting and disclosure practice. Then it developed prospective solutions to be implemented using blockchain thinking (BT). BT was pinpointed in its fundamental pillars, while scenario analysis and design research help the study to elaborate possible implementations (artifacts). Scenario analysis was applied to identify the problems and to provide motivation and objectives for the solutions. The elaboration of these scenarios allows researchers the ability to define and list objectives to design a solution through artifacts, which meet some of the solution objectives. The designed research science (DSR)

approach further benefited by the elaboration of use-cases based on unified modeling language (UML).

With the aim of creating a genuine contribution, not only regarding theory but also in practice, the paper presented two cases of use-case diagrams. The first case is the implementation of BT to safeguard the reliability of data on sustainability issues on supply chain. In this scenario, the free and unlimited access to such enormous amount of data (such Big Data stands for) related to all aspects of supply chain management might help public policymakers and governments to better control the implementation of policies, as in case of the safety of workers. For instance, practical implications of our study include but are not limited to: (a) industry perspectives by supporting organizations to develop processes that can streamline carbon data gathering across supply chain, facilitating cross-border policies adoption (i.e., EU carbon adjustment mechanism), making efficiencies and understanding the risk areas that might suffer in case of external shocks (i.e., COVID-19, economic uncertainty, resource shortages); (b) policymaking perspective by mandating reliability checks on up and down-streams supply chains, and/or requiring the use of technologies to streamline the gathering of carbon data to allow the implementation of specific carbon pricing policies, and requiring organizations to provide their stakeholders assurance about their supply chain carbon data management processes.

A limit of our study was its main nature of being predictive and conceptual, enforced by the proposition use-cases, but this approach stands usually as the first pillar of any software and technology design approach. Further analysis on a case-by-case organizational basis might be required to further test and understand the applicability of our concepts.

Our study might be helpful, not only to discuss the theoretical advancement of sustainability reporting due to a technology change but it provides software designers and all the people involved in sustainability assessment, a practical starting point to reflect on the usability of this innovative technology.

Future developments can be several as the BT application for businesses are infinite. Future studies can demonstrate how the enhancing characteristics of BT might improve these areas, for instance at the technological level, studies on sustainability assessment tools, software, and services for BT are yet to be developed. Considering the nature of distributed public ledger such as the blockchain, a radical shift in the technological paradigm of any corporations, the challenge of discussing implications on data usage, openness versus closeness, and disclosure versus divulgation are important fields for future investigations. Concerning its theoretical level, our paper invokes business scholars to develop suggestions and provide real cases to test the feasibility of BT for sustainability management and reporting, and it asks, with the same importance, a discussion of the theory of sustainability in a more fluid and democratic context.

Author Contributions: L.C., conceptualization, methodology, and use-cases. J.Z., state of the art. D.K.A., editing and final proof. S.D.S., abstract, project coordination, and conclusions. All authors have read and agreed to the published version of the manuscript.

Funding: This research has not received any external funding.

Institutional Review Board Statement: Not applicable.

Informed Consent Statement: Not applicable.

Data Availability Statement: Not applicable.

Conflicts of Interest: The authors declare no conflict of interest.

References

1. Guthrie, J.; Parker, L.D.; Dumay, J.; Milne, M.J. What Counts for Quality in Interdisciplinary Accounting Research in the next Decade. *Account. Audit. Account. J.* **2019**, *32*, 2–25. [[CrossRef](#)]
2. Contrafatto, M.; Rusconi, G. Social Accounting in Italy: Origins and Developments. *Soc. Environ. Account. J.* **2005**, *25*, 3–8. [[CrossRef](#)]
3. Parker, L.D. Social and Environmental Accountability Research. *Account. Audit. Amp Account. J.* **2005**, *18*, 842–860. [[CrossRef](#)]

4. Bebbington, J.; Gray, R.; Thomson, I.; Walters, D. Accountants' Attitudes and Environmentally-Sensitive Accounting. *Account. Bus. Res.* **1994**, *24*, 109–120. [[CrossRef](#)]
5. Gray, R.; Owen, D.; Adams, C. Some Theories for Social Accounting? *A Review Essay and a Tentative Pedagogic Categorisation of Theorisations around Social Accounting.* **2009**, *4*, 1–54. [[CrossRef](#)]
6. Arena, C.; Bozzolan, S.; Michelon, G. Environmental Reporting: Transparency to Stakeholders or Stakeholder Manipulation? An Analysis of Disclosure Tone and the Role of the Board of Directors. *Corp. Soc. Responsib. Environ. Manag.* **2014**, *22*, 346–361. [[CrossRef](#)]
7. Michelon, G.; Pilonato, S.; Ricceri, F.; Roberts, R.W. Behind Camouflaging: Traditional and Innovative Theoretical Perspectives in Social and Environmental Accounting Research. *Sustain. Account. Manag. Policy J.* **2016**, *7*, 2–25. [[CrossRef](#)]
8. Corazza, L.; Truant, E.; Scagnelli, S.D.; Mio, C. Sustainability Reporting after the Costa Concordia Disaster: A Multi-Theory Study on Legitimacy, Impression Management and Image Restoration. *Account. Audit. Account. J.* **2020**, *33*, 1909–1941. [[CrossRef](#)]
9. Zaman, R.; Farooq, M.B.; Khalid, F.; Mahmood, Z. Examining the Extent of and Determinants for Sustainability Assurance Quality: The Role of Audit Committees. *Bus. Strategy Environ.* **2021**, *30*, 2887–2906. [[CrossRef](#)]
10. Schleicher, T.; Walker, M. Bias in the Tone of Forward-Looking Narratives. *Account. Bus. Res.* **2010**, *40*, 371–390. [[CrossRef](#)]
11. Kanbaly, M.; Hellmann, A.; He, L. Infographics in Corporate Sustainability Reports: Providing Useful Information or Used for Impression Management? *J. Behav. Exp. Financ.* **2020**, *26*, 100309. [[CrossRef](#)]
12. Fasan, M.; Mio, C. Fostering Stakeholder Engagement: The Role of Materiality Disclosure in Integrated Reporting. *Bus. Strategy Environ.* **2016**, *26*, 288–305. [[CrossRef](#)]
13. Khan, M.; Serafeim, G.; Yoon, A. Corporate Sustainability: First Evidence on Materiality. *Account. Rev.* **2016**, *91*, 1697–1724. [[CrossRef](#)]
14. Lai, A.; Melloni, G.; Stacchezzini, R. What Does Materiality Mean to Integrated Reporting Preparers? An Empirical Exploration. *Meditari Account. Res.* **2017**, *25*, 533–552. [[CrossRef](#)]
15. Wagner, R.; Seele, P. Uncommitted Deliberation? Discussing Regulatory Gaps by Comparing GRI 3.1 to GRI 4.0 in a Political CSR Perspective. *J. Bus. Ethics* **2017**, *146*, 333–351. [[CrossRef](#)]
16. Machado, B.A.A.; Dias, L.C.P.; Fonseca, A. Transparency of Materiality Analysis in GRI-based Sustainability Reports. *Corp. Soc. Responsib. Environ. Manag.* **2020**, *28*, 570–580. [[CrossRef](#)]
17. Truant, E.; Corazza, L.; Scagnelli, S.D. Sustainability and Risk Disclosure: An Exploratory Study on Sustainability Reports. *Sustainability* **2017**, *9*, 636. [[CrossRef](#)]
18. Dumay, J.; Bernardi, C.; Guthrie, J.; la Torre, M. Barriers to Implementing the International Integrated Reporting Framework. *Meditari Account. Res.* **2017**, *25*, 461–480. [[CrossRef](#)]
19. Burritt, R.; Schaltegger, S. Accounting towards Sustainability in Production and Supply Chains. *Br. Account. Rev.* **2014**, *46*, 327–343. [[CrossRef](#)]
20. Bocken, N.M.P.; Short, S.W. Unsustainable Business Models—Recognising and Resolving Institutionalised Social and Environmental Harm. *J. Clean. Prod.* **2021**, *312*, 127828. [[CrossRef](#)]
21. Formentini, M.; Taticchi, P. Corporate Sustainability Approaches and Governance Mechanisms in Sustainable Supply Chain Management. *J. Clean. Prod.* **2016**, *112*, 1920–1933. [[CrossRef](#)]
22. Hahn, R.; Weidtmann, C. Transnational Governance, Deliberative Democracy, and the Legitimacy of ISO 26000. *Bus. Soc.* **2012**, *55*, 90–129. [[CrossRef](#)]
23. Spangenberg, J.H. Hot Air or Comprehensive Progress? A Critical Assessment of the SDGs. *Sustain. Dev.* **2016**, *25*, 311–321. [[CrossRef](#)]
24. Hahn, R.; Kühnen, M. Determinants of Sustainability Reporting: A Review of Results, Trends, Theory, and Opportunities in an Expanding Field of Research. *J. Clean. Prod.* **2013**, *59*, 5–21. [[CrossRef](#)]
25. Bakarich, K.M.; Castonguay, J.; O'Brien, P.E. The Use of Blockchains to Enhance Sustainability Reporting and Assurance. *Account. Perspect.* **2020**, *19*, 389–412. [[CrossRef](#)]
26. Swan, M. Blockchain Thinking: The Brain as a Decentralized Autonomous Corporation [Commentary]. *IEEE Technol. Soc. Mag.* **2015**, *34*, 41–52. [[CrossRef](#)]
27. Swan, M. *Blockchain: Blueprint for a New Economy*; O'Reilly Media, Inc.: Sebastopol, CA, USA, 2015; ISBN 1491920475.
28. Underwood, S. Blockchain beyond Bitcoin. *Commun ACM* **2016**, *59*, 15–17. [[CrossRef](#)]
29. Al-Htaybat, K.; von Alberti-Alhtaybat, L. Big Data and Corporate Reporting: Impacts and Paradoxes. *Account. Audit. Account. J.* **2017**, *30*, 850–873. [[CrossRef](#)]
30. Arnaboldi, M.; Busco, C.; Cuganesan, S. Accounting, Accountability, Social Media and Big Data: Revolution or Hype? *Account. Audit. Account. J.* **2017**, *30*, 762–776. [[CrossRef](#)]
31. Cockcroft, S.; Russell, M. Big Data Opportunities for Accounting and Finance Practice and Research. *Aust. Account. Rev.* **2018**, *28*, 323–333. [[CrossRef](#)]
32. Gandomi, A.; Haider, M. Beyond the Hype: Big Data Concepts, Methods, and Analytics. *Int. J. Inf. Manag.* **2015**, *35*, 137–144. [[CrossRef](#)]
33. Omoteso, K. The Application of Artificial Intelligence in Auditing: Looking Back to the Future. *Expert Syst. Appl.* **2012**, *39*, 8490–8495. [[CrossRef](#)]

34. Sutton, S.G.; Holt, M.; Arnold, V. “The Reports of My Death Are Greatly Exaggerated”—Artificial Intelligence Research in Accounting. *Int. J. Account. Inf. Syst.* **2016**, *22*, 60–73. [CrossRef]
35. Ray, P.P.; Dash, D.; Moustafa, N. Streaming Service Provisioning in IoT-Based Healthcare: An Integrated Edge-Cloud Perspective. *Trans. Emerg. Telecommun. Technol.* **2020**, *31*. [CrossRef]
36. Bebbington, J.; Unerman, J. Achieving the United Nations Sustainable Development Goals. *Account. Audit. Account. J.* **2018**, *31*, 2–24. [CrossRef]
37. Flower, J. The International Integrated Reporting Council: A Story of Failure. *Crit. Perspect. Account.* **2015**, *27*, 1–17. [CrossRef]
38. Swart, R.J.; Raskin, P.; Robinson, J. The Problem of the Future: Sustainability Science and Scenario Analysis. *Glob. Environ. Change* **2004**, *14*, 137–146. [CrossRef]
39. Geerts, G.L. A Design Science Research Methodology and Its Application to Accounting Information Systems Research. *Int. J. Account. Inf. Syst.* **2011**, *12*, 142–151. [CrossRef]
40. Gregor, S.; Hevner, A.R. Positioning and Presenting Design Science Research for Maximum Impact. *MIS Q.* **2013**, *37*, 337–355. [CrossRef]
41. Hevner, A.; Chatterjee, S. *Design Research in Information Systems Theory and Practice*; Springer: Berlin, Germany, 2010; ISBN 1441956530.
42. PwC. *Time for Trust Report*; PwC: London, UK, 2020.
43. PwC. *The Blockchain Challenge Nobody Is Talking About*; PwC: London, UK, 2018.
44. Stevens, P. *Decrypt*; ConsenSys: New York, NY, USA, 2020.
45. Weber, O. Financial Sector Sustainability Regulations and Voluntary Codes of Conduct: Do They Help to Create a More Sustainable Financial System. In *Designing a Sustainable Financial System*; Palgrave Macmillan: Cham, Switzerland, 2018; pp. 383–404. [CrossRef]
46. US SIF. *US SIF Trends Report 13th Edition*; US SIF: Washington, DC, USA, 2021.
47. EuroSIF. *Fostering Investor Impact 2021*; EuroSIF: Brussels, Belgium, 2021.
48. Bernardi, C.; Stark, A.W. Environmental, Social and Governance Disclosure, Integrated Reporting, and the Accuracy of Analyst Forecasts. *Br. Account. Rev.* **2018**, *50*, 16–31. [CrossRef]
49. Dumay, J. A Critical Reflection on the Future of Intellectual Capital: From Reporting to Disclosure. *J. Intellect. Cap.* **2016**, *17*, 168–184. [CrossRef]
50. Burritt, R.L.; Schaltegger, S. Sustainability Accounting and Reporting: Fad or Trend? *Account. Audit. Account. J.* **2010**, *23*, 829–846. [CrossRef]
51. Paschek, D.; Luminosu, C.T.; Draghici, A. Automated Business Process Management in Times of Digital Transformation Using Machine Learning or Artificial Intelligence. *MATEC Web Conf.* **2017**, *121*, 4007. [CrossRef]
52. Hörisch, J.; Johnson, M.P.; Schaltegger, S. Implementation of Sustainability Management and Company Size: A Knowledge-Based View. *Bus. Strategy Environ.* **2014**, *24*, 765–779. [CrossRef]
53. Johnson, M. Awareness and Application of Sustainability Management Tools in Small and Medium-Sized Enterprises. *Acad. Manag. Proc.* **2013**, *2013*, 16036. [CrossRef]
54. Johnson, M.P. Sustainability Management and Small and Medium-Sized Enterprises: Managers’ Awareness and Implementation of Innovative Tools. *Corp. Soc. Responsib. Environ. Manag.* **2013**, *22*, 271–285. [CrossRef]
55. Nakamoto, S. Bitcoin: A Peer-to-Peer Electronic Cash System. *Decentralized Bus. Rev.* **2008**. Available online: <http://www.debr.io/article/21260-bitcoin-a-peer-to-peer-electronic-cash-system> (accessed on 23 November 2022).
56. Carlozo, L. What Is Blockchain? *J. Account.* **2017**, *224*, 29.
57. Rückeshäuser, N. Do We Really Want Blockchain-Based Accounting? Decentralized Consensus as Enabler of Management Override of Internal Controls. In *Wirtschaftsinformatik 2017 Proceedings*; Institute of Computer Science and Social Studies: St. Gallen, Switzerland, 2017.
58. Lamport, L.; Shostak, R.; Pease, M. The Byzantine Generals Problem. *ACM Trans. Program. Lang. Syst.* **1982**, *4*, 382–401. [CrossRef]
59. De Kruijff, J.; Weigand, H. Understanding the Blockchain Using Enterprise Ontology. *Lect. Notes Comput. Sci. (Incl. Subser. Lect. Notes Artif. Intell. Lect. Notes Bioinform.)* **2017**, *10253 LNCS*, 29–43. [CrossRef]
60. Kokina, J.; Mancha, R.; Pachamanova, D. Blockchain: Emergent Industry Adoption and Implications for Accounting. *J. Emerg. Technol. Account.* **2017**, *14*, 91–100. [CrossRef]
61. Coyne, J.G.; McMickle, P.L. Can Blockchains Serve an Accounting Purpose? *J. Emerg. Technol. Account.* **2017**, *14*, 101–111. [CrossRef]
62. Zhou, F.; Liu, Y. Blockchain-Enabled Cross-Border E-Commerce Supply Chain Management: A Bibliometric Systematic Review. *Sustainability* **2022**, *14*, 15918. [CrossRef]
63. Tapscott, D.; Tapscott, A. *Blockchain Revolution: How the Technology behind Bitcoin Is Changing Money, Business, and the World*; Penguin: London, UK, 2016; ISBN 0143196871.
64. Demirkan, S.; Demirkan, I.; McKee, A. Blockchain Technology in the Future of Business Cyber Security and Accounting. *J. Manag. Anal.* **2020**, *7*, 189–208. [CrossRef]
65. Dai, J.; Vasarhelyi, M.A. Toward Blockchain-Based Accounting and Assurance. *J. Inf. Syst.* **2017**, *31*, 5–21. [CrossRef]
66. Kozłowski, S. An Audit Ecosystem to Support Blockchain-Based Accounting and Assurance. In *Continuous Auditing*; Emerald Publishing Limited: Bingley, UK, 2018; pp. 299–313. [CrossRef]

67. Bonsón, E.; Bednárová, M. Blockchain and Its Implications for Accounting and Auditing. *Meditari Account. Res.* **2019**, *27*, 725–740. [[CrossRef](#)]
68. Seele, P. Digitally Unified Reporting: How XBRL-Based Real-Time Transparency Helps in Combining Integrated Sustainability Reporting and Performance Control. *J. Clean. Prod.* **2016**, *136*, 65–77. [[CrossRef](#)]
69. Zhang, L.; Pei, D.; Vasarhelyi, M.A. Toward a New Business Reporting Model. *J. Emerg. Technol. Account.* **2017**, *14*, 1–15. [[CrossRef](#)]
70. Biondi, L.; Dumay, J.; Monciardini, D. Using the International Integrated Reporting Framework to Comply with EU Directive 2014/95/EU: Can We Afford Another Reporting Façade? *Meditari Account. Res.* **2020**, *28*, 889–914. [[CrossRef](#)]
71. Carnegie, G.; Parker, L.; Tsahuridu, E. It's 2020: What Is Accounting Today? *Aust. Account. Rev.* **2020**, *31*, 65–73. [[CrossRef](#)]
72. Carungu, J.; di Pietra, R.; Molinari, M. Mandatory vs. Voluntary Exercise on Non-Financial Reporting: Does a Normative/Coercive Isomorphism Facilitate an Increase in Quality? *Meditari Account. Res.* **2020**, *29*, 449–476. [[CrossRef](#)]
73. Martin Fowler, K.S. *UML Distilled: Applying the Standard Object Modeling Language*; Addison-Wesley: Reading, MA, USA, 1997.
74. Petriu, D.C.; Woodside, M. Software Performance Models from System Scenarios in Use Case Maps. In *Computer Performance Evaluation: Modelling Techniques and Tools*; Springer: Berlin/Heidelberg, Germany, 2002; pp. 141–158.
75. Wirfs-Brock, R. Designing Scenarios: Making the Case for a Use Case Framework. *Smalltalk Rep.* **1993**, *3*, 9–20.
76. Jacobson, I. *Object-Oriented Software Engineering: A Use Case Driven Approach*; Pearson Education India: Delhi, India, 1993; ISBN 8131704084.
77. Rumbaugh, J.; Jacobson, I.; Booch, G. *Unified Modeling Language Reference Manual*; Pearson Higher Education: London, UK, 2004.
78. Porru, S.; Pinna, A.; Marchesi, M.; Tonelli, R. Blockchain-Oriented Software Engineering: Challenges and New Directions. In Proceedings of the 2017 IEEE/ACM 39th International Conference on Software Engineering Companion (ICSE-C), Buenos Aires, Argentina, 20–28 May 2017; IEEE: New York, NY, USA, 2017.
79. Glaser, F. Pervasive Decentralisation of Digital Infrastructures: A Framework for Blockchain Enabled System and Use Case Analysis. In Proceedings of the Hawaii International Conference on System Sciences 2017 (HICSS-50), Hilton Waikoloa Village, HI, USA, 4–7 January 2017.
80. Easterbrook, S.; Singer, J.; Storey, M.-A.; Damian, D. Selecting Empirical Methods for Software Engineering Research. In *Guide to Advanced Empirical Software Engineering*; Springer: London, UK, 2008; pp. 285–311. [[CrossRef](#)]
81. Martínez-Ferrero, J.; García-Sánchez, I.-M. Coercive, Normative and Mimetic Isomorphism as Determinants of the Voluntary Assurance of Sustainability Reports. *Int. Bus. Rev.* **2017**, *26*, 102–118. [[CrossRef](#)]
82. O'Dwyer, B.; Owen, D.L. Assurance Statement Practice in Environmental, Social and Sustainability Reporting: A Critical Evaluation. *Br. Account. Rev.* **2005**, *37*, 205–229. [[CrossRef](#)]
83. Junior, R.M.; Best, P.J.; Cotter, J. Sustainability Reporting and Assurance: A Historical Analysis on a World-Wide Phenomenon. *J. Bus. Ethics* **2013**, *120*, 1–11. [[CrossRef](#)]
84. Fuhrmann, S.; Ott, C.; Looks, E.; Guenther, T.W. The Contents of Assurance Statements for Sustainability Reports and Information Asymmetry. *Account. Bus. Res.* **2016**, *47*, 369–400. [[CrossRef](#)]
85. Rossi, A.; Tarquinio, L. An Analysis of Sustainability Report Assurance Statements. *Manag. Audit. J.* **2017**, *32*, 578–602. [[CrossRef](#)]
86. Eisenhardt, K.M. Agency Theory: An Assessment and Review. *Acad. Manag. Rev.* **1989**, *14*, 57–74. [[CrossRef](#)]

Disclaimer/Publisher's Note: The statements, opinions and data contained in all publications are solely those of the individual author(s) and contributor(s) and not of MDPI and/or the editor(s). MDPI and/or the editor(s) disclaim responsibility for any injury to people or property resulting from any ideas, methods, instructions or products referred to in the content.