



METHOD ARTICLE

**REVISED** **A GC-IRMS method for measuring sulfur isotope ratios of carbonyl sulfide from small air samples [version 2; peer review: 2 approved]**

Sophie L. Baartman <sup>1</sup>, Maarten C. Krol <sup>1,2</sup>, Thomas Röckmann<sup>1</sup>, Shohei Hattori<sup>3,4</sup>, Kazuki Kamezaki <sup>5,6</sup>, Naohiro Yoshida<sup>5,7,8</sup>, Maria Elena Popa <sup>1</sup>

<sup>1</sup>Institute for Marine and Atmospheric research Utrecht (IMAU), Utrecht University, Utrecht, 3584 CS, The Netherlands

<sup>2</sup>Meteorology and Air Quality, Wageningen University & Research Center, Wageningen, 6708 PB, The Netherlands

<sup>3</sup>Department of Chemical Science and Engineering, School of Materials and Chemical Technology, Tokyo Institute of Technology, Yokohama, 226-8502, Japan

<sup>4</sup>International Center for Isotope Effects Research (ICIER), Nanjing University, Nanjing, 210023, China

<sup>5</sup>Department of Material and Life Sciences, Faculty of Science & Technology, Sophia University, Tokyo, 102-8554, Japan

<sup>6</sup>Environmental Management Research Institute, National Institute of Advanced Industrial Science and Technology (AIST), Tsukuba, 305-8569, Japan

<sup>7</sup>Earth-Life Science Institute, Tokyo Institute of Technology, Tokyo, 152-8550, Japan

<sup>8</sup>National Institute of Information and Communications Technology, Tokyo, 184-8795, Japan

**v2** First published: 13 Sep 2021, 1:105  
<https://doi.org/10.12688/openreseurope.13875.1>

Latest published: 08 Mar 2022, 1:105  
<https://doi.org/10.12688/openreseurope.13875.2>

**Abstract**

A new system was developed for measuring sulfur isotopes  $\delta^{33}\text{S}$  and  $\delta^{34}\text{S}$  from atmospheric carbonyl sulfide (COS) on small air samples of several liters, using pre-concentration and gas chromatography – isotope ratio mass spectrometry (GC-IRMS). Measurements of COS isotopes provide a tool for quantifying the COS budget, which will help towards better understanding climate feedback mechanisms. For a 4 liter sample at ambient COS mixing ratio, ~500 parts per trillion (ppt), we obtain a reproducibility error of 2.1 ‰ for  $\delta^{33}\text{S}$  and 0.4 ‰ for  $\delta^{34}\text{S}$ . After applying corrections, the uncertainty for an individual ambient air sample measurement is 2.5 ‰ for  $\delta^{33}\text{S}$  and 0.9 ‰ for  $\delta^{34}\text{S}$ . The ability to measure small samples allows application to a global-scale sampling program with limited logistical effort. To illustrate the application of this newly developed system, we present a timeseries of ambient air measurements, during the fall and winter of 2020 and 2021 in Utrecht, the Netherlands. The observed background values were  $\delta^{33}\text{S} = 1.0 \pm 3.4$  ‰ and  $\delta^{34}\text{S} = 15.5 \pm 0.8$  ‰ (VCDT). The maximum observed COS mixing ratios was only 620 ppt. This, in combination with the relatively high  $\delta^{34}\text{S}$  suggests that the Netherlands receives little COS-containing anthropogenic emissions. We observed a change in COS mixing ratio and  $\delta^{34}\text{S}$  with different air mass origin, as modelled with HYSPLIT backward trajectory analyses. An increase of 40 ppt in mean COS mixing ratio was observed

**Open Peer Review**

Approval Status

1

2

**version 2**(revision)  
08 Mar 2022**version 1**

13 Sep 2021

[view](#)[view](#)

1. **Sinikka Lennartz**, University of Oldenburg, Oldenburg, Germany

2. **Ralph Keeling** , University of California, San Diego, San Diego, USA

Any reports and responses or comments on the article can be found at the end of the article.

between fall and winter, which is consistent with the expected seasonal cycle in the Netherlands. Additionally, we present the results of samples from a highway tunnel to characterize vehicle COS emissions and isotopic composition. The vehicle emissions were small, with COS/CO<sub>2</sub> being 0.4 ppt/ppm; the isotopic signatures are depleted relatively to background atmospheric COS.

### Keywords

carbonyl sulfide, sulfur isotope, atmosphere, biosphere, mass spectrometry



This article is included in the [European Research Council \(ERC\)](#) gateway.



This article is included in the [Earth and Environmental Sciences](#) gateway.



This article is included in the [Analytical Techniques](#) collection.

**Corresponding author:** Sophie L. Baartman ([s.l.baartman@uu.nl](mailto:s.l.baartman@uu.nl))

**Author roles:** **Baartman SL:** Formal Analysis, Investigation, Methodology, Visualization, Writing – Original Draft Preparation; **Krol MC:** Conceptualization, Funding Acquisition, Project Administration, Supervision, Writing – Review & Editing; **Röckmann T:** Conceptualization, Supervision, Writing – Review & Editing; **Hattori S:** Methodology, Writing – Review & Editing; **Kamezaki K:** Investigation, Writing – Review & Editing; **Yoshida N:** Writing – Review & Editing; **Popa ME:** Conceptualization, Supervision, Writing – Review & Editing

**Competing interests:** No competing interests were disclosed.

**Grant information:** This project has received funding from the European Research Council (ERC) under the European Union's Horizon 2020 research and innovation program under grant agreement No 742798 (COS-OCS; to M. C. Krol) and by Japan Society for the Promotion of Science KAKENHI Grants 20J01445 (K.K.), JP17H06105 (N.Y. and S.H.), and JP20H01975 (S.H.) under the Ministry of Education, Culture, Sports, Science and Technology, Japan.

**Copyright:** © 2022 Baartman SL *et al.* This is an open access article distributed under the terms of the [Creative Commons Attribution License](#), which permits unrestricted use, distribution, and reproduction in any medium, provided the original work is properly cited.

**How to cite this article:** Baartman SL, Krol MC, Röckmann T *et al.* **A GC-IRMS method for measuring sulfur isotope ratios of carbonyl sulfide from small air samples [version 2; peer review: 2 approved]** Open Research Europe 2022, 1:105 <https://doi.org/10.12688/openreseurope.13875.2>

**First published:** 13 Sep 2021, 1:105 <https://doi.org/10.12688/openreseurope.13875.1>

**REVISED Amendments from Version 1**

This is the updated version of the article after the peer review reports. Some minor changes have been incorporated into the text, especially in the description of the calibration procedure. Figure 2 has been changed to make the inset better visible. The calculation of the error on the isotope measurement results has been slightly altered following peer review suggestions (see the peer review report and response). Therefore, Equation 3 has been changed to not include the calibration error anymore and the reported errors on the isotope values are somewhat lower than in the previous version of this article. The underlying data has also been updated to incorporate this change in error calculation.

**Any further responses from the reviewers can be found at the end of the article**

**Introduction**

Carbonyl sulfide (COS) is the most abundant sulfur-containing trace gas in the atmosphere, with an average mixing ratio of 500 parts per trillion (ppt) (Chin & Davis, 1995). It has a lifetime of around two years, which permits it to be transported into the stratosphere. There, it is likely the main source of stratospheric sulfur aerosols (SSA) during volcanically quiescent periods. These aerosols regulate the Earth's albedo and play a crucial role in stratospheric chemistry (Brühl *et al.*, 2012; Crutzen, 1976; Kremser *et al.*, 2016). Understanding the role of COS in stratospheric chemistry is therefore highly important for understanding cooling mechanisms of the Earth.

Another way in which COS can be used to better understand the climate system is through its potential use for the quantification of gross primary production (GPP) of the biosphere. It is difficult to derive GPP from measurements of CO<sub>2</sub>, because flux measurements only yield the sum of the two almost canceling fluxes: GPP and respiration. COS, however, is taken up by plants in an essentially one-way reaction, during which it follows almost the same pathway as CO<sub>2</sub> (Protoschill-Krebs & Kesselmeier, 1992; Protoschill-Krebs *et al.*, 1996; Whelan *et al.*, 2018). Therefore, measurements of the unidirectional COS uptake could be used as a tracer for photosynthetic CO<sub>2</sub> uptake and help to quantify GPP (Asaf *et al.*, 2013; Berry *et al.*, 2013; Blonquist *et al.*, 2011; Campbell *et al.*, 2008; Kooijmans *et al.*, 2016).

The largest natural source of COS is the ocean, in the form of direct emission and indirect emission via carbon disulfide (CS<sub>2</sub>) and possibly dimethyl sulfide (DMS) (Kettle *et al.*, 2002; Lennartz *et al.*, 2017; Lennartz *et al.*, 2020). The other main sources of COS are anthropogenic, and include rayon production, aluminum production, coal combustion and other smaller sources such as biomass burning (Stinecipher *et al.*, 2019; Zumkehr *et al.*, 2018). Sinks of COS include the above-mentioned large biosphere uptake, and a smaller and less well characterized soil uptake sink (Whelan *et al.*, 2018). Unfortunately, the budget of COS is still not well understood and large uncertainties exist in the strengths of the sinks and particularly the sources of COS (Whelan *et al.*, 2018). Modelling

studies and satellite observations can help further constrain the COS budget (Barkley *et al.*, 2008; Glatthor *et al.*, 2017; Kettle *et al.*, 2002; Kuai *et al.*, 2014; Suntharalingam *et al.*, 2008; Yousefi *et al.*, 2019) but the latest studies still point to an unknown missing source of 230 – 432 Gg S a<sup>-1</sup> (Ma *et al.*, 2021). Isotopic measurements could provide a tool for overcoming these budget uncertainties, as they can be used to characterize source and sink contributions. Different types of COS sources have distinct sulfur isotopic compositions, which can be used to identify these sources. In COS removal reactions, the lighter isotope is usually preferred over the heavier one because of differences in chemical bond strength. These principles can be used to characterize the influences of sources and sinks. The sulfur isotope ratios are reported as δ values, which are defined by Equation 1 and Equation 2, where R is the ratio between the heavier and the lighter isotope, which is then used to calculate the δ<sup>33</sup> and δ<sup>34</sup> values. The δ values are reported relative to the international sulfur standard; the Vienna Canyon Diabolo Troilite (VCDT).

$${}^{33,34}R = [{}^{33,34}\text{S}]/[{}^{32}\text{S}] \quad (1)$$

$$\delta^{33,34}\text{S} = \frac{R_{\text{sample}}^{33,34}}{R_{\text{standard}}^{33,34}} - 1 \quad (2)$$

To date, two methods have been developed for measuring the sulfur isotopic composition of COS. The first method, described by Hattori *et al.* (2015) and Kamezaki *et al.* (2019), uses gas chromatography - continuous flow isotope ratio mass spectrometry (GC-CF-IRMS) to measure S<sup>+</sup> fragment ions, and requires very large air samples of several hundreds of liters. This is because of the dependence of the isotope values on the sample amount, usually referred to as non-linearity, that arises when using smaller sample sizes. The second method was first presented by Angert *et al.* (2019) and uses a multi collector inductively coupled plasma mass spectrometer (MC-ICP-MS), which can measure sulfur isotopic composition of COS from smaller sample sizes of around 3 L. The method we present here is in principle similar to the CF-IRMS method of Hattori *et al.* (2015), but optimized for small sample volumes of 3 – 4 L of air. This is possible because we characterized the nonlinearity of our system and we apply a correction factor to our isotope measurements that accounts for this nonlinearity.

Newman *et al.* (1991) presented the first global estimate of δ<sup>34</sup>S in tropospheric COS of 11 ‰, based on mass-balance calculations. Angert *et al.* (2019) measured COS sulfur isotopologues from clean ambient air at the Canary Islands and Israel. They found a mean δ<sup>34</sup>S of 13.4 ± 0.5‰, which is roughly in agreement with the estimate by Newman *et al.*, 1991. Kamezaki *et al.* (2019) showed results from four measurements in Yokohama, with a mean δ<sup>34</sup>S of 10.5 ± 0.4 ‰. They explained their slightly lower δ<sup>34</sup>S than Angert *et al.* (2019) by the presence of anthropogenic COS emissions from China, which have an estimated lower δ<sup>34</sup>S value of 3 to 8 ‰ (Davidson *et al.*, 2021; Hattori *et al.*, 2020). In a later paper, Hattori *et al.* (2020) presented new results from air collected at three different locations at different latitudes in Japan during both winter and summer. They found significantly higher mixing

ratios and lower  $\delta^{34}\text{S}$  values for the most northerly location in winter, which predominantly received air from highly industrialized regions in China. In addition, they found higher  $\delta^{34}\text{S}$  values when the air was predominantly coming from the East, where the ocean source dominates. Based on these results and the Keeling plot intercepts (Keeling, 1961; Pataki *et al.*, 2003), Hattori *et al.* (2020) deduced an anthropogenic emission value for  $\delta^{34}\text{S}$  of 4 to 5 ‰ and a value of 19 ‰ for the ocean source. These results are roughly in agreement with the newest results presented by Davidson *et al.* (2021), who measured COS mixing ratios and  $\delta^{34}\text{S}$  from 89 air samples from multiple locations around the world. By dividing their dataset in high (>600 ppt) and low (<600 ppt) mixing ratio data and calculating the Keeling plot intercepts they found an anthropogenic source value of  $8.1 \pm 1$  ‰. Davidson *et al.* (2021) also measured direct and indirect COS emissions from the Mediterranean Sea and found a combined  $\delta^{34}\text{S}$  signature of  $13.2 \pm 2$  ‰ for the ocean source. Thus, the ocean source  $\delta^{34}\text{S}$  signature is estimated to be between 13 and 19 ‰ (Davidson *et al.*, 2021; Hattori *et al.*, 2020). The anthropogenic emission signature is estimated to be slightly lower than the ambient  $\delta^{34}\text{S}$  and ranges between 4 and 8 ‰. The biosphere fractionation sink was estimated by Davidson *et al.* (2021) in a plant chamber experiment, and yielded a fractionation factor  $^{34}\epsilon$  of  $-1.9 \pm 0.3$  ‰ for one plant species, thus making the remaining COS pool enriched in  $\delta^{34}\text{S}$ . The fractionation during uptake by three different types of soil bacteria has been measured by Kamezaki *et al.* (2016) and Ogawa *et al.* (2017) and they found a similar small negative  $^{34}\epsilon$  between  $-3.7$  and  $-2.1$  ‰. The destruction reaction of COS with hydroxyl radicals (OH) will likely make the COS more enriched in the heavier sulfur and carbon isotopes (Schmidt *et al.*, 2012). An experimental study by Hattori *et al.* (2011) found sulfur isotopic fractionation factors for photolysis destruction of COS of  $-3.7 \pm 4.5$  ‰ and  $1.1 \pm 4.2$  ‰ for  $^{33}\epsilon$  and  $^{34}\epsilon$ , respectively. The sulfur isotope effects during the reaction with atomic oxygen ( $\text{O}(^3\text{P})$ ) were investigated by Hattori *et al.* (2012) and a fractionation factor  $^{34}\epsilon = -21.7 \pm 6.2$  ‰ was found. However, large uncertainties in these values remain and more research is needed on the isotopic compositions or fractionation factors of sources and sink processes of COS, such as traffic and biomass burning emissions, destruction by atmospheric oxidation and photolysis in the stratosphere.

In summary, substantial progress has been made in the last years on measuring COS sulfur isotopologues. However, in order to fully characterize the global COS budget and its sulfur isotopic composition, more measurements are needed, including atmospheric measurements from several different climatic zones, latitudes and altitudes (Ma *et al.*, 2021). This paper presents the methodology and first results of our new system that can measure sulfur isotopes of COS using CF-IRMS at Utrecht University, the Netherlands. We present results from online ambient air measurements at the Utrecht University campus, over a time-span of five months in the fall and winter of 2020/2021. We also provide an estimate on the isotopic signature of COS vehicle emissions from air samples taken in a highway tunnel.

## Methods

### Measurement system

Figure 1 shows a schematic overview of the pre-concentration coupled with a CF-IRMS system, that was developed at the Institute for Marine and Atmospheric research Utrecht (IMAU). The system is partially similar to the ones described in Hattori *et al.* (2015), Kamezaki *et al.* (2019) and Angert *et al.* (2019) and consists of several traps to collect the COS, while discarding the other air compounds. In short, the sample gas is first directed through a cooled Tenax trap, where the COS is preferentially collected. The collected gas is then transferred to the cryo-focus and afterwards further purified in a GC column, before being sent via an open split system to the IRMS for isotope ratio measurements.

Samples, reference gases and COS-free “zero” air for blank measurements are connected to the system with a 12 port multi-position selection valve (EMT2CSD12MWE, dead-end path, 200C/400 psi, Vico Valco Instruments Co. Inc., USA). The selected sample is passed through a dryer, which consists of a glass tube containing magnesium perchlorate ( $\text{Mg}(\text{ClO}_4)_2$ ) (63095, Fluka Analytical, Switzerland), held in place by silane treated glass wool at both ends of the tube. As we mostly measure already pre-dried samples, the dryer is replaced approximately every three to four months, when the material starts to look moist. The Tenax trap consists of a 1/16” sulfonert-treated tube (29229, Restek, USA) filled with approximately 200 mg of Tenax TA (60 – 80 mesh, 11982, Supelco Analytical, USA) and silane treated glass wool (20411, Supelco, USA), and is cooled with a mixture of ethanol and dry ice to  $-72$  °C to trap COS. The Tenax trap also contains some 1mm diameter glass beads to allow for slightly larger pore spaces, to reduce the flow resistance of the trap. Before use, the Tenax is conditioned for 24 hours at a temperature of 200 °C under helium flow. After every measurement, the Tenax trap is flushed forward with a helium flow of 30 mL/min and heated to 200 °C for 30 minutes, in order to limit memory from the previous sample. Sample flow into the trap is kept at or below 80 mL/min using a mass flow controller, depending on the pressure of the sample being measured. A membrane vacuum pump (type N920 G, KNF, France) is used at the outlet of the trap in order to maintain a high enough flow rate, even when measuring samples with lower than atmospheric pressure. After the desired volume of sample gas is injected the collected gas is released from the Tenax by heating the trap to 130 °C with a heating wire. The gas is transported with helium carrier gas, through a six-port valve (A4C6UWM, Vico Valco Instruments Co. Inc., USA) to the cryo-focus trap, where the gas is collected for 30 min at a temperature of  $-196$  °C, using liquid nitrogen. This second cold trap consists of a 320  $\mu\text{m}$  inner diameter capillary tube (P/N 064052, Trajan, Australia) and is used to focus the COS in a smaller volume and release it all at the same time, creating a narrower peak on the chromatograph than if only the first cold trap would be used, which is larger and heats up slower. After this focusing step, the remaining compounds in the gas mixture are separated on a gas chromatographic column (CP7549, PorapLOT Q, 25m, 0.25mm, Agilent Technologies, USA) heated

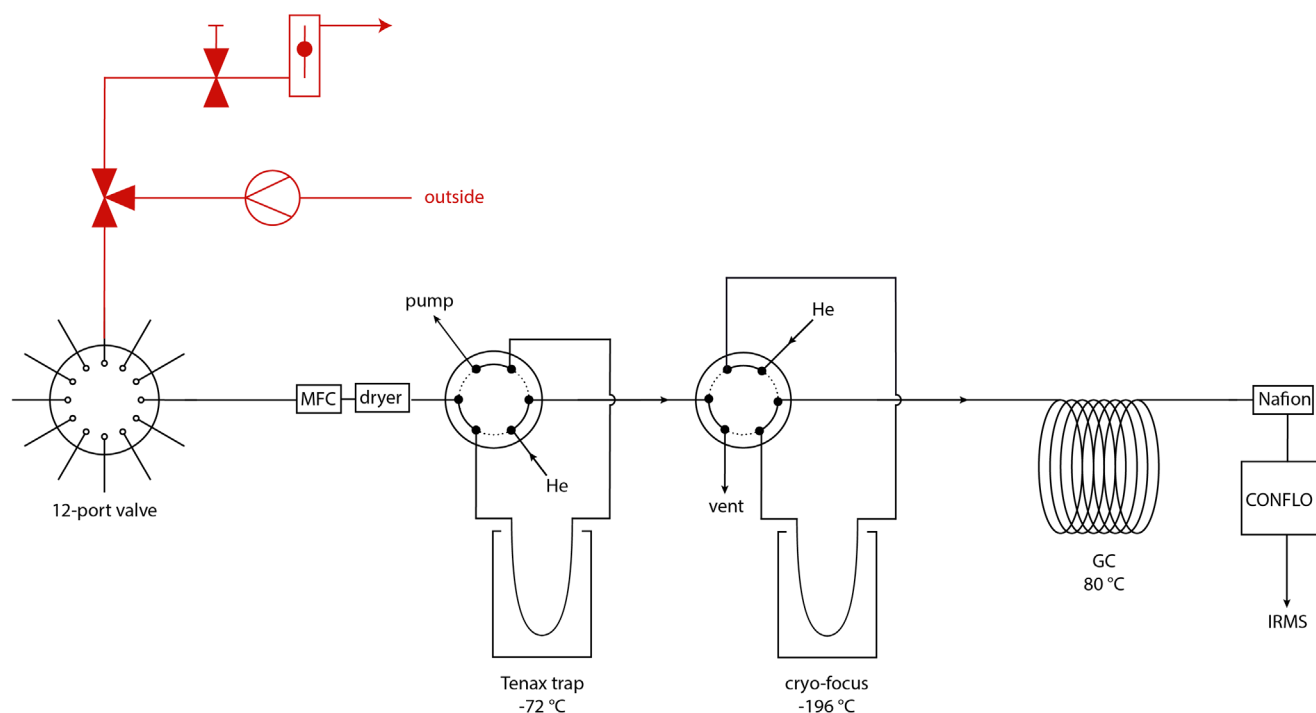

**Figure 1.** Schematic overview of the COS pre-concentration system, with in red the ambient air sampling system including a three-way valve, a pump, a needle valve and a flow controller and in black the pre-concentration system, with a 12-port dead-end multi-position valve, a mass flow controller (MFC), a magnesium perchlorate dryer, two 6 port valves, a Tenax TA trap and a cryo-focus trap, a gas chromatographic column (GC), a Nafion dryer, a ConFlo interface and an isotope ratio mass spectrometer.

to 80 °C. A ConFlo IV universal continuous flow interface (IQLAAEGAATFAETMAXB, Thermo Fisher Scientific, USA) is used to inject the gas into the IRMS (IQLAAEGAATFAB-HMZZZ, Delta V Advantage, Thermo Fisher Scientific, USA), where the COS is ionized and fragmented, with a  $S^+$  fragment yield of approximately 30 % (NIST, 2018). The fragment ions  $^{32}S^+$ ,  $^{33}S^+$  and  $^{34}S^+$  are collected on triple Faraday collector cups for  $m/z$  32, 33 and 34, with resistors  $3 \times 10^9 \Omega$ ,  $1 \times 10^{12} \Omega$  and  $3 \times 10^{11} \Omega$ . Altogether, one sample measurement takes 2 to 3 hours, depending on initial pressure and the volume of sample that was injected. The injected sample volume was chosen based on the expected COS mixing ratio in the sample, and adjusted so that the sample COS peak area would be similar to the reference gas COS peak area.

At the start of each measurement, a working gas is injected into the IRMS via the ConFlo three times. As working gas, pure  $O_2$  is used, which has the three isotope masses needed. Additionally, since pure COS is highly toxic, it is much safer and more convenient to use  $O_2$  as a working gas. The isotope ratios of all sample and reference measurements are first calculated relative to our working gas. From these, the sample values are calculated relative to the reference gas, which is calibrated against the international standard VCDT (NIST, 2013). This calibration process and other data corrections and processing are further elaborated in the next section.

Figure 2 shows an example of a chromatogram of a COS measurement with the three square peaks of the working gas at the beginning, followed by additional peaks including the COS sample peak. The peak that arrives after the  $O_2$  square peaks, with a retention time of around 320 seconds, is likely from the  $O_2^+$  fragment of remaining  $CO_2$  that is also being trapped in the Tenax trap, as this peak increases for gases with elevated  $CO_2$  concentrations. Most of the  $CO_2$  that is trapped on the Tenax is removed through timed valve switching, thus we expect that the peak on the chromatogram is only the “tail” of the peak. At 410 seconds, the COS peak elutes, with the  $m/z$  of 33 and 34 traces having larger amplitudes than  $m/z$  32 trace because of the much higher resistors. The several peaks that follow the COS peak, but are well separated, mostly show on  $m/z$  33 and are possibly organic compounds as mentioned by Kamezaki *et al.* (2019).

#### Testing the pre-concentration system

**Reproducibility.** The reproducibility of the system was characterized by measuring 1 L, 2 L and 3 L volumes of the same gas with 6 to 8 repetitions, using the same method for all measurements. The gases used were target gas 2 (ambient air reference gas for CO isotope measurements) and a 5 L stainless steel cylinder filled with ambient air during EastGrip 2018 in Greenland. From these measurements, we estimated the typical reproducibility as the two-tailed 70% confidence

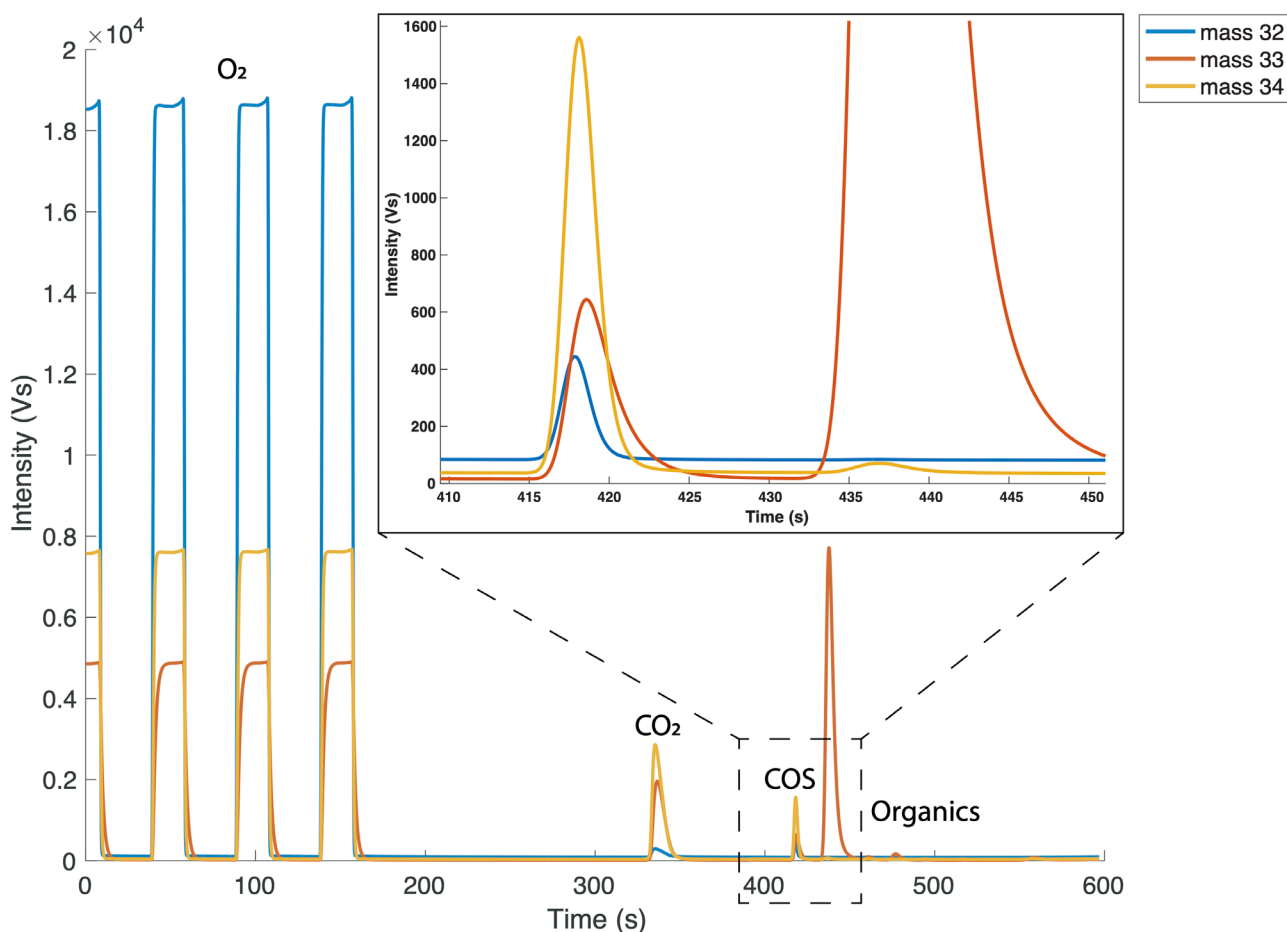

**Figure 2. Full chromatograph of one reference gas measurement.** First three peaks are the  $O_2$  working gas peaks. The chromatogram starts with  $O_2$  in the source flushing because the IRMS source is constantly flushed with  $O_2$  in between measurements. After the working gas peaks we see a peak which is suspected to be  $CO_2$ , which is followed by the small COS peak, and several other peaks that appear on  $m/z$  33 only. The inset in the top right corner zooms in on the COS peak.

interval using the student t-distribution with  $n-1$  degrees of freedom. The total error of individual sample measurements is slightly higher because of the addition of the nonlinearity correction error of  $\delta^{34}S$  and the error from the calibration of both  $\delta^{33}S$  and  $\delta^{34}S$ , as shown below. The statistical analysis and all other analyses and creation of figures further described in this paper were performed using MATLAB R2020b.

**Nonlinearity.** Nonlinearity is the dependence of  $\delta$  values on the integrated ion signal (peak area) of all isotope masses contributing to a certain peak in the IRMS chromatogram. Hattori *et al.* (2015) found a strong nonlinearity for their system between a COS total peak area of 0 and 8 Vs (mass 32, 33 and 34 combined), and they therefore decided to only measure total peak areas above 8 Vs. This meant, however, that a very large sample size of several hundreds of liters was required for a single measurement. For our measurements, in order to be able to measure smaller samples, the nonlinearity of the

system was characterized and a correction factor to account for this nonlinearity was determined and applied to our data. This was done in two ways. For the first set of experiments, a 2 L glass flask (Norrmag, Ilmenau, Germany with PCTFE sealing; Rothe *et al.*, 2005) was filled with a gas mixture containing 2 ppb COS and zero air. The flask was connected on one side to the COS isotope measurement system and the other side of the flask was connected to a zero air cylinder. While keeping overpressure on the flask from the zero air cylinder, a series of 3 L measurements was conducted during which the gas mixture in the flask was more and more diluted with zero air with each subsequent measurement. The second method for characterizing the nonlinearity was done by injecting different volumes of the target gas, starting at 1 L and increasing in steps of 250 to 500 mL up to a volume of 4 L. In both methods, the dependence of the isotope values on the peak area was characterized by fitting a function through the data. From this trendline, a correction factor for the isotope values

was calculated. The non-simultaneous 68% function bounds give the uncertainty of this function and thus the uncertainty added to the data when applying the nonlinearity correction.

The error from the nonlinearity correction and the reproducibility were combined following error propagation using Equation 3. This error represents the internal error, or how well individual measurements can be related to the internal lab scale.

$$\sigma_{total} = \sqrt{\sigma_{reprod}^2 + \sigma_{nonlin}^2} \quad (3)$$

**Calibration.** All measurements were first measured against the O<sub>2</sub> working gas. Each sample was measured against our lab reference gas, which was a high-pressure cylinder, filled with ambient air at the surface of Greenland during the 2017 EastGRIP campaign (Eastgrip, 2018). For the calibration against the international sulfur standard Vienna Canyon Diablo Troilite (VCDT), we used four COS calibration gases produced and calibrated at Tokyo Institute for Technology, which contained high mixing ratio COS (50 to 200 ppm) in nitrogen. The first calibration gas called “10.5 % COS” was a commercially obtained COS gas in high-purity He (99.99995 % purity; Japan Fine Products Co. Ltd., Kawasaki, Japan). The other three calibration gases were synthesized as described in Hattori *et al.* (2015) from three kinds of sulfur powders: Wako, Sigma-Aldrich and a mixture of the two. The synthesized COS gases were prepared at Tokyo Institute of Technology through a reaction of the sulfur powders and CO gas (99.99 % purity; Japan Fine Products Co. Lt., Kawasaki, Japan) in glass tubes at 573 K for 24 hours. The gases were purified using a GC equipped with a thermal conductivity detector (GC-14B; Shimadzu, Kyoto, Japan) and a packed column (Porapak Q, 2 mm i.d. 2.4 m; GL Science, Tokyo, Japan) maintained at 333 K.

The above-mentioned calibration gases were assigned  $\delta^{34}\text{S}$  values on the VCDT scale by both an off-line and on-line method performed in the Geo Science Laboratory in Nagoya, Japan. For the off-line method, 20  $\mu\text{mol}$  of each COS gas was reacted with an alkaline zinc solution (zinc acetate NaOH), and the sulfur was precipitated as ZnS overnight. The ZnS was washed by adding 18 M $\Omega\text{cm}$  water (ZRXQ005T0, MerckMillipore, Corp., Burlington, MA, USA) and centrifuging, three times. The ZnS was combusted to SO<sub>2</sub>, of which the  $\delta^{34}\text{S}$  values were measured on the VCDT scale by elemental analyzer (EA)-IRMS. The total error (1  $\sigma$ ) derived from repeatability and accuracy was 0.4 ‰ for the off-line method. The remaining COS gases were pressurized with high-purity nitrogen (99.99995 % purity; Japan Fine Products Co. Ltd., Kawasaki, Japan) to 1067 mbar and were stored in 3 L SilcoCan canisters (27303, Restek Corp., Pennsylvania, USA) for the on-line measurement. The on-line measurements were performed by Tokyo Institute of Technology according to the method developed previously (Hattori *et al.*, 2015; Kamezaki *et al.*, 2019). The total error (1  $\sigma$ ) derived from repeatability, size dependence and accuracy was 0.3 ‰ for the on-line method. The  $\delta^{34}\text{S}_{\text{VCDT}}$  values of the on-line and off-line measurements were very similar. The off-line values were used for fitting the calibration line, which yielded a calibration range for  $\delta^{34}\text{S}$  of  $-8.9$  ‰ to  $13.3$  ‰.

The calibration of  $\delta^{33}\text{S}$  of these same calibration gases on the VCDT scale was done by calculating their values relatively to the  $\delta^{33}\text{S}$  of a calibration gas (11 ppm COS) that has been used for  $\delta^{33}\text{S}$  calibration in the past by Kamezaki *et al.* (2019). This method assumes that the  $\delta^{33}\text{S}$  of this calibration gas has not changed since it was last measured in 2017. This assumption is supported by the fact that the  $\delta^{34}\text{S}$  value of this same gas has been confirmed several times between 2017 and the present and no drift has been found. A mass-dependent relationship between  $\delta^{33}\text{S}$  and  $\delta^{34}\text{S}$  was found for all other calibration gases in the past, thus we assume that no mass-independent drift has occurred in the “11 ppm OCS” calibration gas. The calibration range for  $\delta^{33}\text{S}$  is  $-7.8$  ‰ to  $6.6$  ‰.

During our calibration procedure, the high COS mixing ratio calibration gases were diluted into 6 L canisters using zero air to a mixing ratio of 30 to 50 ppb. Two of the gases were chosen for further dilutions, which were the ones that had isotopic compositions that were most different from ambient air. These gases were diluted further in 5 L cylinders to a pressure of 100 bar, and a mixing ratio of approximately 700 ppt. During the calibration procedure we performed measurements of different volumes of all the dilutions made from the initial gases. We measured at different total peak areas between 1 and 6 Vs, to check for any nonlinearity effects.

All measurements were combined to derive a calibration curve, where the assigned  $\delta^{33}\text{S}_{\text{VCDT}}$  and  $\delta^{34}\text{S}_{\text{VCDT}}$  values from Japan are plotted against the  $\delta^{33}\text{S}$  and  $\delta^{34}\text{S}$  values measured in Utrecht, relatively to our reference gas. Trendlines were fitted using a linear regression method (York *et al.*, 2004), which considers the errors in both the X and Y direction. A slope of the calibration line  $>1$  was considered as an evidence of scale contraction and, if needed, a correction method was developed. The results of the calibration procedure are presented below. The 68% uncertainty bounds were calculated using a bootstrapping resampling procedure to calculate the calibration error, which indicates how well the measurements in Utrecht can be linked to measurements in other labs on the VCDT scale.

#### **Data corrections, quality check and long-term stability.**

At the beginning and end of each measurement sequence, blank measurements were performed, which were either 3 L injections of COS-free “zero air”, or “no-load” blanks in which no gas was injected into the pre-concentration system. The blank was found to be less than 5 % of the reference gas peak area and these blank measurement values were used to correct the peak area and isotope values of the measurements.

To monitor the long-term measurement stability, COS in air from a target cylinder (5 L, dried ambient air filled in Greenland in 2017 at 39m depth) was measured approximately weekly. A second target cylinder was introduced after the first gas cylinder was exhausted (ambient air high-pressure cylinder no. 1341). If an error occurred during the pre-concentration phase (e.g. incorrectly timed valve switching, sample not opened properly), or if a measurement looked clearly not good (e.g. bad GC separation or strange peak shape), those measurements were flagged and not included into the final dataset. In the

end approximately 7 % of the measurements, including blank and reference gas measurements, had to be flagged due to the above-mentioned reasons.

**Additional tests.** This section describes some additional tests that were performed with the COS measurement system. These tests were performed to fully characterize the behavior of separate elements of the measurement set-up and to optimize the steps undertaken during the measurement procedure. The detailed results of these tests can be found in *Underlying data* (Baartman *et al.*, 2021).

Some materials are known or suspected to influence COS mixing ratios by either emitting COS or trapping it on their surfaces (COSANOVA, n.d.). Therefore, several parts of the pre-concentration system were tested to make sure they did not affect our COS measurements. Firstly, the interference of the magnesium perchlorate dryer was tested, by comparing measurements of the same known gas with and without dryer. The influence of the vacuum pump at the end of the Tenax trap was also tested, by comparing measurements of the same gas with the pump turned on or off. No significant influences of the dryer or the vacuum pump were found.

Several tests were performed to optimize the release of COS from the Tenax trap. We investigated the effect of the heating temperature of the trap on the amount of COS that was released from the trap, in various ways. First, multiple COS isotope measurements were conducted using the same EastGrip 2017 gas cylinder but using different Tenax trap heating temperatures of 100 °C and 130 °C, where the measured COS peak areas were compared. Another test was to heat the Tenax in steps, increasing from room temperature to 200 °C with a 10 °C increase every 10 minutes, to see at which temperature the COS would be released. The effect of the duration of the Tenax trap heating was tested by comparing different heating durations to the COS peak area. The optimal heating procedure for COS release from the Tenax was 130 °C for 30 minutes.

The optimal time for flushing and heating the Tenax trap during the cleaning procedure in between measurements was also tested. This was done by performing 10 measurements with 15 minutes of heating and flushing and 10 measurements of the same EastGrip 2017 gas cylinder with 30 minutes of heating and flushing. The results were compared by checking the trend in COS peak areas within each measurement sequence of 10 measurements. An upward trend in peak areas of the measurements would point to an insufficient cleaning of the Tenax, leading to contamination of the next measurement. The optimal cleaning time for the trap was found to be 30 minutes.

The trapping efficiency of the Tenax trap was tested by placing a second Tenax trap after the first one and measuring a gas with ambient COS mixing ratio (target gas from EGRIP 2017). The COS that escaped the first trap would be trapped on this second trap. The traps were heated separately and the COS released from the trap could be measured independently. Tests

were performed injecting volumes of air of 3 L, 4 L, 5 L and 6 L, to see if any breakthrough would occur at higher injected volumes. The trapping efficiency was found to be 100 % for all injected volumes that were tested.

Because of the presence of other compounds in the chromatogram (Figure 2), we tested the possible interference of several available compounds on the trapping of COS, by measuring gas mixtures with known mixing ratios of 1.6 % CO<sub>2</sub>, 1 % CH<sub>4</sub> and 4.5 % H<sub>2</sub> and comparing these to measurements of gases without those gases present. CO<sub>2</sub> interference was specifically tested since it was suspected to be one of the larger peaks on the chromatogram and since its possible interference was also mentioned by Angert *et al.* (2019). No interference of these compounds on COS trapping was found.

The memory effect and thereby also the blank peak area of the system was tested by first measuring a 3L injection of a gas with a COS mixing ratio of approximately 900 ppt, followed by a sequence of zero air measurements. By inspecting the peak area of the zero air measurements in the chromatogram, the memory effect was characterized. No significant memory was found with the current heating and flushing time of the Tenax, thus the influence of the previous sample measurement on the next is negligible.

#### Ambient air measurements in Utrecht

Ambient air was drawn from outside the Buys Ballot building on the Utrecht University Campus (coordinates: 52.087471, 5.165394) with a sampling system that was directly connected to the pre-concentration system, as indicated in Figure 1 in red. The sampling system consisted of a ¼" Dekabon tube, which ran through a small hole in the wall of the lab to the outside. The opening of the tube was about one meter from the building wall, and at an elevation of approximately 15 m from the ground (on the 6<sup>th</sup> floor). A magnesium perchlorate dryer was installed at the end of the sampling tube and was replaced regularly while sampling. The air was drawn in using a small membrane pump (type PM22874-86, KNF, France), which created a continuous flow rate of around 2 L min<sup>-1</sup>. When sampling air, 80 mL min<sup>-1</sup> was split into the pre-concentration system, while the rest of the air was vented. The pressure of ambient air going into the pre-concentration system was regulated by a needle valve and a flow controller at the outlet of the sampling system. Setting up the system in this way allowed for a continuous high flow through the Dekabon tube, so that there would be no stagnant air in the tube, and therefore less chance of contamination. One measurement with this set-up, including flushing and cleaning time of the Tenax trap, takes three hours.

Because the ambient air was running through the KNF pump before entering the pre-concentration system, we tested the possible interference of this pump on COS mixing ratios and isotopic composition. This was done by connecting one of the target gas cylinders to a 2 L glass flask, and connecting the sampling pump to the other end of the flask. The glass flask was added to create a volume of air between the



pressurized cylinder and the pump, to prevent harm to the cylinder regulator. The outlet of the pump was then connected to the multi-position valve of the pre-concentration system. Using this set-up, we measured the same injected volume of the same gas 10 times. The results of this test were then compared to 10 measurements of the same gas with the same set-up, but with the pump removed. No significant effect of the pump on the measurement results was found.

A series of 15 sequences of COS isotope measurements from ambient air were performed between mid-October 2020 and January 2021, which yielded a total of 80 individual outside air measurement points. Each sequence consisted of four up to 12 ambient air measurements, interspersed with reference gas measurements.

Backward trajectory analysis using the Hybrid Single-Particle Lagrangian Integrated Trajectory model (HYSPLIT) was performed in order to determine the prevailing wind directions during sampling and the main air origins (Stein *et al.*, 2015). The backward trajectories were calculated going back 96 hours from the time of the last sampling, with a new trajectory being calculated every 2 hours during the measurement period for an elevation of 20 m.

### Highway tunnel measurements

The Utrecht University campus is situated close to a busy highway and some highway junctions. As it is reported that cars do emit small amounts of COS both by combustion and tire wear (Lee & Brimblecombe, 2016; Zumkehr *et al.*, 2018), this highway could be a potential local source influencing our ambient air measurements. In order to assess the possible influence of traffic emissions, we collected some samples from a highway tunnel in the Utrecht region. Samples were taken in the Leidsche Rijntunnel (52°05'09.6" N 5°04'32.2" E), which has a length of 1650 m, a speed limit of 100 km/h and consists of four separated unidirectional tubes. The inner tubes have three driving lanes, while the outer have two lanes. The average traffic intensity for this tunnel was 200.000 vehicles per 24 hours (Rijkswaterstaat, 2020). We drove with a 2012 Volkswagen transporter, equipped with a cavity ring-down analyzer, Picarro Inc. G2301. The G2301 was able to measure mixing ratios of CO<sub>2</sub>, CH<sub>4</sub> and H<sub>2</sub>O. For a full description of the van and the analyzers, see Maazallahi *et al.* (2020), who used the same set-up for mobile CH<sub>4</sub> measurements.

The samples for COS analysis were collected in pre-evacuated 6 L ENTECH Silonite canisters as follows: a 1.5 m Dekabon tube was connected to the outside of the van and sticking 1 m upwards from the top of the van door. A magnesium perchlorate dryer was installed between the tubing and the canister, which was replaced every two canisters. When sampling, the canister was opened a couple of seconds after entering the tunnel and closed again some seconds after exiting. An air inflow was maintained all throughout the sampling in the tunnel, however, with the canisters being evacuated at the start, the samples could have been slightly biased to the air

at the entrance of the tunnel. The resulting pressure in the canisters was slightly below atmospheric as no pump was used during the sampling procedure. A total of six canisters was collected during the six tunnel drive throughs, of which one in the inner tube of the tunnel and the other 5 in the outer tubes. One day after sampling, the samples were diluted with COS-free synthetic air to increase the pressure of about 1.7 bar and measured with the COS isotope measurement system. Besides the online measurements, the samples were also measured for CO<sub>2</sub> and CH<sub>4</sub> mixing ratios, using the above mentioned Picarro G2301 instrument.

For interpretation of the COS isotope and concentration data, Keeling plots (Keeling, 1961; Pataki *et al.*, 2003) were created using MATLAB R2020b.

## Results and discussion

### Reproducibility

Figure 3 shows the measurement reproducibility as a function of the measured COS peak area ( $n = 6$  to  $8$ ), where each dot in the scatter plot represents the precision of a set of measurements. A trendline was fitted through the data-points to use as a continuous function for the precision when calculating the error for individual samples. The dependence of the precision on peak area, within the range of our measurements (peak area between 1 and 0.2 Vs), can best be described by the exponential functions given in Equation 4 ( $R^2 = 0.76$ ) and 5 ( $R^2 = 0.40$ ).

$$\sigma_{\delta^{33}\text{S}}(A) = 3.70e^{-0.67A} \quad (4)$$

$$\sigma_{\delta^{34}\text{S}}(A) = 0.97e^{-1.01A} \quad (5)$$

Where  $\sigma$  is the reproducibility error in ‰, and  $A$  is the peak area of a measurement. For reference, a measurement of 4L of ambient air with an ambient mixing ratio of 550 ppt will give a peak area of approximately 0.68 Vs, which would correspond to a system error of 2.1 ‰ for  $\delta^{33}\text{S}$  and 0.4 ‰ for  $\delta^{34}\text{S}$ .

### Nonlinearity

Figure 4 shows the nonlinearity data including a regression line and the 68% functional bounds for the  $\delta^{34}\text{S}$  data. It can be observed that the nonlinearity effect for  $\delta^{34}\text{S}$  is minor and only a small correction was needed for the ambient air measurements, which had peak areas between 0.65 and 0.8 Vs (indicated with the shaded area in Figure 4). Equation 6 and 7 describe the correction made for  $\delta^{34}\text{S}$  with a peak area smaller than 1 Vs, where  $A_{\text{ref}}$  is the peak area of the reference measurements and  $A_{\text{sample}}$  is the sample peak area. For  $\delta^{33}\text{S}$ , the nonlinearity effect only starts to be evident from peak areas smaller than 0.4 Vs. Since our dataset does not include any measurements with such low peak areas, no correction for  $\delta^{33}\text{S}$  was applied.

$$\delta^{34}\text{S}_{\text{correction}} = [5.17e^{-0.49A_{\text{ref}}} + 9.66e^{0.1A_{\text{ref}}}] - [5.17e^{-0.49A_{\text{sample}}} + 9.66e^{0.1A_{\text{sample}}}] \quad (6)$$

$$\delta^{34}\text{S}_{\text{corrected}}(A_{\text{sample}} \geq 1) = \delta^{34}\text{S}(A_{\text{sample}} \geq 1) + \delta^{34}\text{S}_{\text{correction}}(A_{\text{sample}} \geq 1) \quad (7)$$

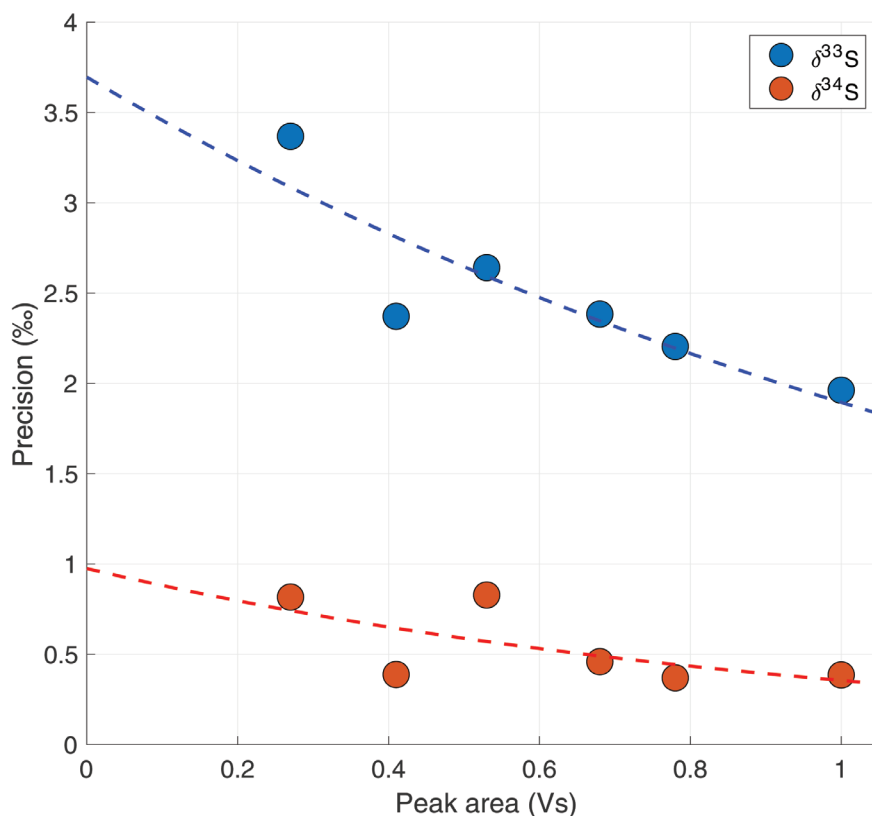

**Figure 3.** The precision in ‰ as a function of total peak area in Volt seconds (Vs). Every data point represents the 70% confidence interval from a student t-distribution of 6 – 8 measurements combined.

### Calibration

The results of the calibration are available in *Underlying data* (Baartman *et al.*, 2021). Table 1 shows the results of the calibration with the four calibration gases: Wako, Sigma-Aldrich, Mix (a mixture of Wako and Sigma-Aldrich) and 10.5 % COS. Figure 5 shows the assigned  $\delta^{33}\text{S}_{\text{VCDT}}$  and  $\delta^{34}\text{S}_{\text{VCDT}}$  values of the calibration gases against the results of our measurements relative to the reference gas. These were used to calculate the calibration functions for our measurements, also shown in the figure.

For  $\delta^{34}\text{S}$ , the slope of the calibration line is  $1.01 \pm 0.01$ , which means there was no significant scale contraction and no correction was necessary. The calibration gases gave us a broad calibration range, from  $\delta^{34}\text{S} = -15.7 \text{ ‰}$  to  $+13.3 \text{ ‰ VCDT}$ , bracketing the atmospheric  $\delta^{34}\text{S}$  values. For  $\delta^{33}\text{S}$ , a slope of  $1.15 \pm 0.12$  was found, which means that there may be some small-scale contraction effect for  $\delta^{33}\text{S}$  and a correction was applied. Furthermore, a larger spread in the measurement data for  $\delta^{33}\text{S}$  lead to a larger error of the calibration line (red dotted lines in Figure 5), and to a substantially larger total error. One of the calibration gases (gas 2, Sigma-Aldrich) showed a larger spread in the results for both isotopes, which increased the uncertainty in both calibration lines, but especially the

calibration line of  $\delta^{33}\text{S}$ . When combining the errors from the reproducibility, the nonlinearity correction and the calibration, the total error for a 4 L ambient air sample is 3.3 ‰ for  $\delta^{33}\text{S}$  and 0.9 ‰ for  $\delta^{34}\text{S}$ .

**Additional tests.** The magnesium perchlorate dryer did not have a significant effect on the amount of COS trapped in the Tenax trap nor on the isotopic composition of the measurements. There was no significant difference in mean peak area or  $\delta^{33}\text{S}$  and  $\delta^{34}\text{S}$  with and without the dryer. Because the presence of water in the system could be detrimental to the pre-concentration system, we decided to keep a dryer the line before the Tenax trap for all measurements.

The membrane pump at the end of the system also did not significantly change the peak area nor the isotopic composition of the COS measurements. This pump allowed us to measure at higher flows and measure from samples until lower pressures, thus the pump was included for all measurements.

The optimal heating temperature of the Tenax for COS release to the focus trap is 130 °C. This temperature yielded the highest peak area for the same amount of injected gas, and when heating to higher temperatures, no more COS

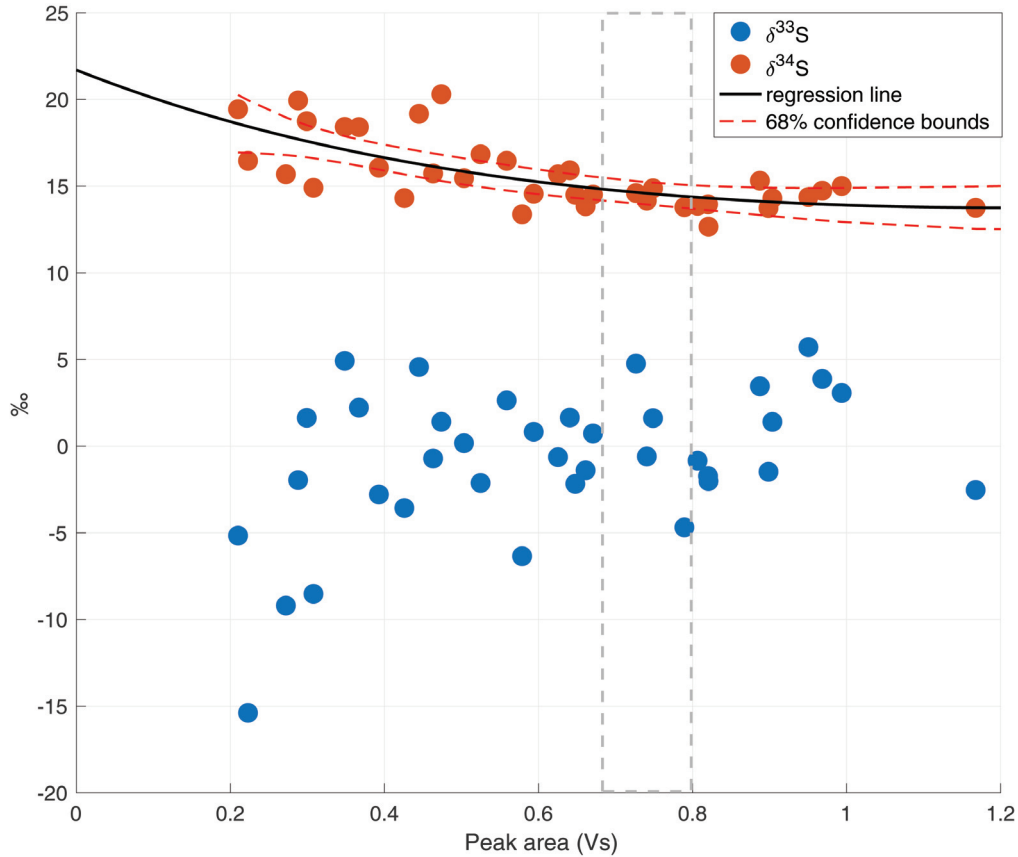

**Figure 4.** Nonlinearity plot for both  $\delta^{33}\text{S}$  and  $\delta^{34}\text{S}$ , with the total peak area in Volt seconds (Vs) on the x axis and the isotope values in ‰ on the y axis. The black line is the linear regression line for  $\delta^{34}\text{S}$ , including the 68% confidence bounds in red dashed lines. The grey dashed lines indicate the usual peak area for a 4 L ambient air measurement.

**Table 1.** Results of the COS calibration with four calibration gases “Wako”, “Sigma-Aldrich”, “Mix” and “10.5 % OCS”, where  $\delta^{34}\text{S}_{\text{ref-Utrecht}}$  and  $\delta^{33}\text{S}_{\text{ref-Utrecht}}$  are the isotope values measured by our measurement system in Utrecht,  $\delta^{34}\text{S}_{\text{off-line}}$  are the  $\delta^{34}\text{S}$  values measured by the off-line method in Japan,  $\delta^{34}\text{S}_{\text{on-line}}$  are the  $\delta^{34}\text{S}$  values measured by the on-line method in Japan and  $\delta^{33}\text{S}_{\text{vs “11 ppm OCS” gas}}$  are the  $\delta^{33}\text{S}$  values on the VCDT scale calculated relatively to the  $\delta^{33}\text{S}$  of a calibration gas called “11 ppm OCS” that was used previously for the  $\delta^{33}\text{S}$  calibration by [Kamezaki et al. \(2019\)](#).

Gas	$\delta^{34}\text{S}_{\text{ref-Utrecht}}$	$\delta^{34}\text{S}_{\text{vcdt off-line}}$	$\delta^{34}\text{S}_{\text{VCDT on-line}}$	$\delta^{33}\text{S}_{\text{ref-Utrecht}}$	$\delta^{33}\text{S vs “11 ppm OCS” gas}$
Wako	$-24.3 \pm 0.4$	$-8.9 \pm 0.4$	$-9.3 \pm 0.3$	$-8.7 \pm 2.9$	$-4.9 \pm 0.4$
Sigma-Aldrich	$-21.8 \pm 0.8$	$-6.5 \pm 0.4$	$-6.1 \pm 0.3$	$-10.1 \pm 6.3$	$-3.5 \pm 0.4$
Mix	$-30.7 \pm 1.2$	$-15.7 \pm 0.4$	$-15.0 \pm 0.3$	$-10 \pm 3.3$	$-7.8 \pm 0.4$
10.5 % COS	$-2.9 \pm 0.4$	$13.3 \pm 0.4$	$13.5 \pm 0.3$	$1.9 \pm 2.9$	$6.6 \pm 0.4$

was released from the trap. It was found that most of the COS was already released at room temperature, which was also noticed by [Tangerman \(1986\)](#). The optimal cleaning time of the trap in between measurements was found to be 30 minutes. During the Tenax trapping efficiency test with the second Tenax trap we found that the peak area of COS released from

the second trap was equal to blank measurements. This test was performed up to volumes of 6 L of injected air. In all tests, the Tenax trap had a >99 % trapping efficiency.

The presence of  $\text{CO}_2$ ,  $\text{CH}_4$  or nitrogen did not have an influence on the trapping efficiency or isotopic composition of

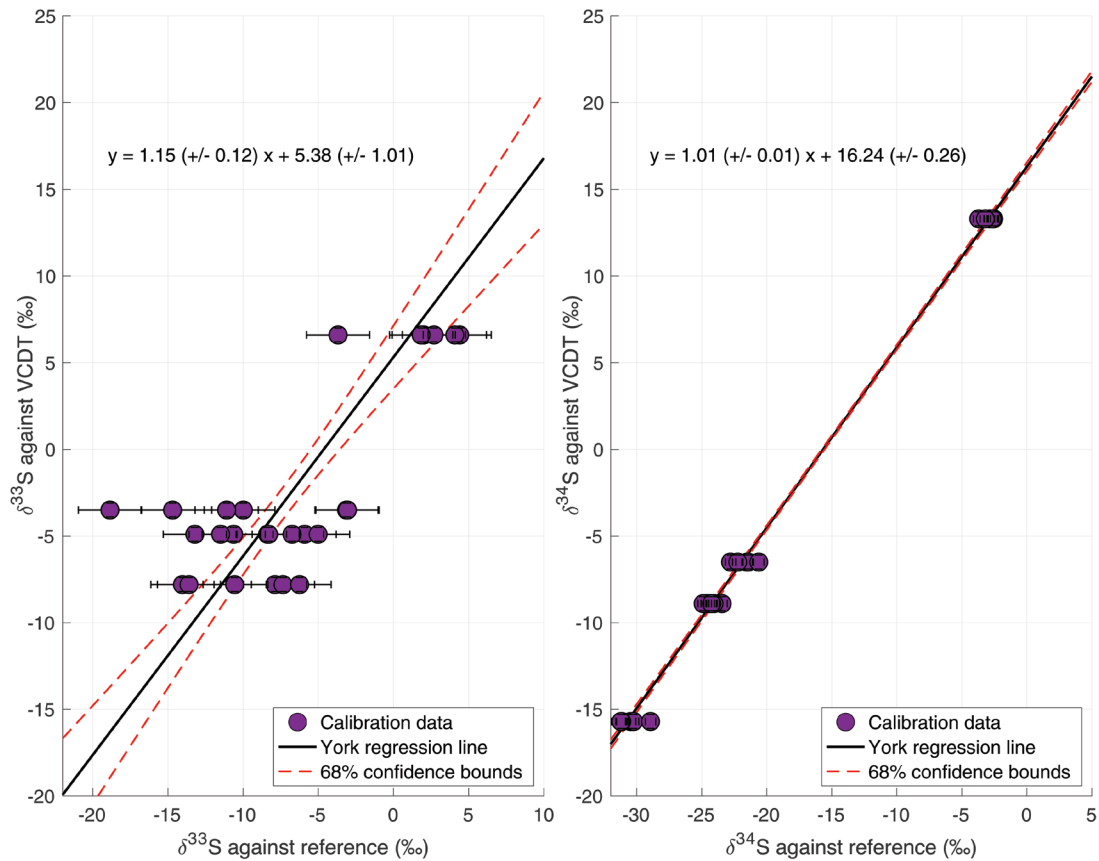

**Figure 5. Results of the isotope calibration of  $\delta^{33}\text{S}$  and  $\delta^{34}\text{S}$  based on calibration gases provided by Tokyo Institute of Technology.** The data points represent the individual calibration measurements. The black line is the York regression line (York *et al.*, 2004), and the red dashed lines represent the 68% confidence bounds of the regression line.

the measured COS, which is in agreement with similar tests performed by Angert *et al.* (2019).

When testing the memory effect in the system, we found that the peak area of the first zero air measurement after the sample measurement was 5.1 % of the sample measurement peak size. The peak area did not decrease much in the subsequent zero air measurements. By the 9th measurement, the peak area had decreased only to 4.9 % of the sample peak size. The other type of blank measurements, where no sample was loaded at all, also yielded a peak area between 2 and 5 % of the sample measurement peak area. We therefore assumed that the interference of the previous gas on the next measurement was minimal, and that our system has a constant 5 % blank level. However, we made sure to always measure a 3 L zero air injection after a measurement of a gas with higher COS mixing ratio, in order to minimize a potential memory effect on the subsequent measurement.

#### Long term stability of the measurement system

Figure 6 shows the time series of online ambient air measurements with the target gas measurements plotted as grey

and purple asterisks in the background. Target measurements were performed throughout the measurement period in order to monitor long-term variability and characterize potential drift in the system. The two different target gases are indicated as different color asterisks in the figure. It can be observed that for the COS mixing ratio there is little variability in these target measurements on the daily scale and also no evidence of drift on the longer time-scale. The variations in COS mixing ratios of the ambient air measurements are clearly larger than in the target measurements. For  $\delta^{34}\text{S}$ , the day-to-day variability of the target is up to a maximum of 2 ‰ and there is no evidence for drift visible on longer time-scales. The error of the target measurements over the course of the measurement period was 0.5 ‰ (1  $\sigma$ ). The day-to-day variability of the target measurements is larger for  $\delta^{33}\text{S}$ ; from 5 ‰ up to around 12 ‰, indicating that measurements of  $\delta^{33}\text{S}$  with our system are less stable and we should be careful with drawing conclusions on small variations of  $\delta^{33}\text{S}$  in sample measurements. However, also for  $\delta^{33}\text{S}$  there is no apparent long-term drift in the target measurements, and the error of the target over the measurement period was 3.4 ‰ (1  $\sigma$ ), which is similar to the total error for an ambient concentration 4 L air sample.

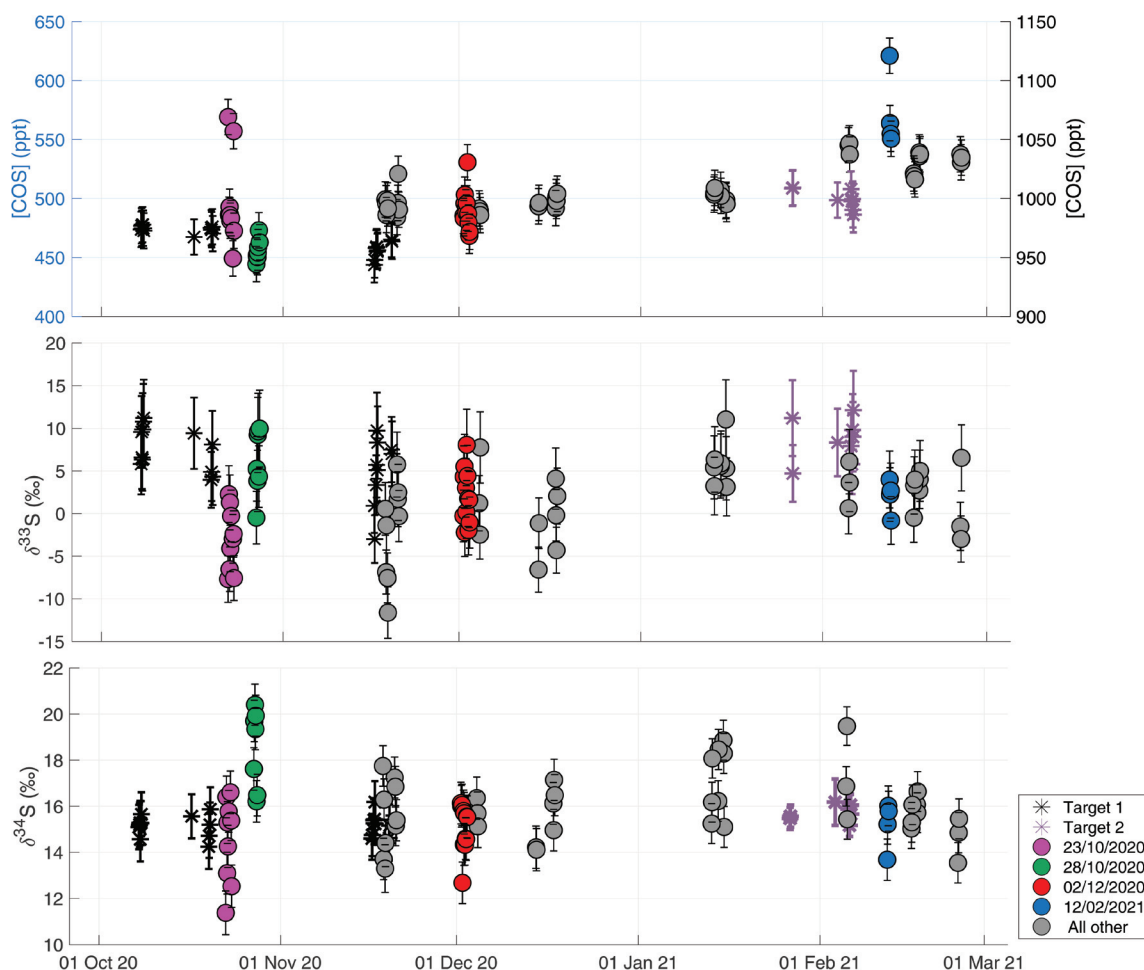
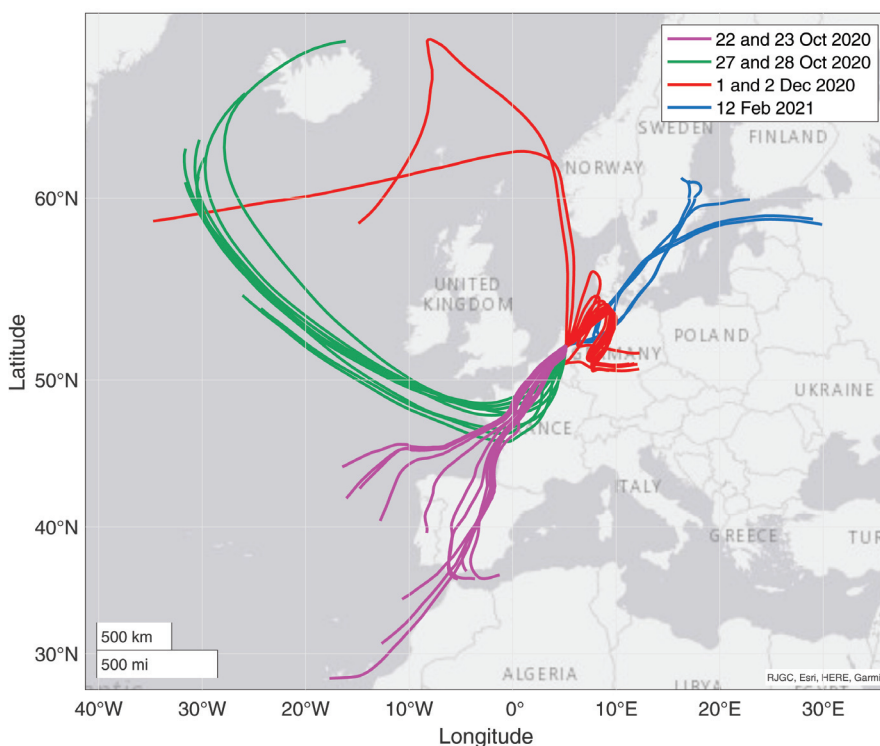

**Figure 6. Ambient air time-series plotted together with measurements of two target gases in black and purple asterisks, to show the long-term variability of the measurement system.** The second target gas (purple asterisks) was introduced after the first one was exhausted, and has slightly higher mixing ratio than the first target gas (black asterisks). Upper figure shows COS mixing ratio with the ambient air measurements plotted on the left y-axis and the target measurements on the right y-axis. Middle figure shows  $\delta^{33}\text{S}$ , and the lower panel shows  $\delta^{34}\text{S}$ . All data are plotted against date and time on the x-axis. some sequences of special interest are highlighted in the colors pink (Oct 22 – Oct 23), green (Oct 27 – Oct 28), red (Dec 1 – Dec 2) and blue (Feb 12). The grey colors represent all other measurements.

### Ambient air measurements Utrecht

The Utrecht ambient air dataset is available in *Underlying data* (Baartman *et al.*, 2021). Figure 6 shows all air measurements, and, indicated with different colors, measurement sequences of special interest that correspond to the HYSPLIT backward trajectory results shown in Figure 7. The trajectories for all the measurement days in the time-series can be found in *Underlying data*. The mean COS mixing ratio during the measurement period was  $503 \pm 15$  ppt, with a variation between 450 and 650 ppt. An increasing trend was observed in the transition from the fall to the winter season, from a mean of  $488 \pm 15$  ppt in fall to  $530 \pm 15$  ppt in winter. This trend is to be expected as the biosphere is the largest sink of COS and becomes mostly inactive during winter in the Northern Hemisphere (Montzka *et al.*, 2007). The maximum observed mixing ratio observed was 621 ppt on Feb 12<sup>th</sup>

2021. The mean  $\delta^{33}\text{S}$  and  $\delta^{34}\text{S}$  over the measurement period were  $1.1 \pm 3.3$  ‰ VCDT and  $15.7 \pm 0.9$  ‰ VCDT respectively. We estimate the background  $\delta^{33}\text{S}$  and  $\delta^{34}\text{S}$  values in Utrecht by assuming a background COS mixing ratio between 480 and 510 ppt and selecting the mean  $\delta$  values  $\pm 1 \sigma$  from this background mixing ratio selection. Using this method, we obtain background values of  $1.0 \pm 3.4$  ‰ ( $\mu \pm \text{SE}$ ) and  $15.5 \pm 0.8$  ‰ ( $\mu \pm \text{SE}$ ) for  $\delta^{33}\text{S}$  and  $\delta^{34}\text{S}$  respectively. Our background value for  $\delta^{34}\text{S}$  value is slightly higher than the numbers that have been reported in previous studies. Davidson *et al.* (2021) found a mean tropospheric  $\delta^{34}\text{S}$  of  $13.9 \pm 0.1$  ‰ and Hattori *et al.* (2020) estimated a background  $\delta^{34}\text{S}$  of 12 to 13.5 ‰ for Japan. This higher background  $\delta^{34}\text{S}$  and also the lack of very high COS mixing ratios in our measurements from Utrecht could possibly be explained by a lower amount of anthropogenic emissions in this region, but could also be due to a larger



**Figure 7. Results from backward trajectory modelling using HYSPLIT (Stein *et al.*, 2015).** The colors correspond to the measurement days, highlighted with the same colors as the data points in Figure 7.

influence of the biosphere sink that enriched northern hemisphere air masses during summer and fall (Davidson *et al.*, 2021), or a larger contribution of the ocean source. A cross-calibration of measurements between different measurement laboratories would be useful to investigate whether differences in measured background  $\delta^{34}\text{S}$  are significant atmospheric signals or are still due to measurement uncertainty. The value for  $\delta^{33}\text{S}$  of  $1.0 \pm 3.4 \text{ ‰}$  is lower than expected from mass-dependent processes. Equation 8 presents the calculation of  $\Delta^{33}\text{S}$ , which describes the deviation of  $\delta^{33}\text{S}$  from the mass-dependent fractionation line (Farquhar & Wing, 2003; Ono *et al.*, 2006).  $\Delta^{33}\text{S}$  would in this case be slightly negative, however, as there is still a substantial uncertainty in our calibration of the  $\delta^{33}\text{S}$  measurements, we should be careful with the interpretation of these values.

$$\Delta^{33}\text{S} = \delta^{33}\text{S} - [(\delta^{34}\text{S} + 1)^{0.515} - 1] \quad (8)$$

While there are some short-time variations in  $\delta$  values, there is no significant seasonal trend visible in  $\delta^{34}\text{S}$ , with a mean  $\delta^{34}\text{S}$  value in the fall (22 October – 22 December) of  $15.8 \pm 0.9 \text{ ‰}$  and  $16.2 \pm 0.9 \text{ ‰}$  in winter (22 December onwards). Davidson *et al.* (2021) found a seasonal variation in  $\delta^{34}\text{S}$  between spring and fall of  $1.2 \text{ ‰}$ , which was ascribed to the effect of a small fractionation during plant uptake of  $-1.9 \text{ ‰}$ . As our time-series does not include the spring and summer seasons yet, and as the seasonal trend is expected to be small,

it is not surprising that we do not observe such a seasonal trend in our dataset.

More information can be gained from this dataset when looking more closely at the variability on the day-to-day to weekly scale, and a comparison to the backward trajectory analyses shown in Figure 7. Potentially interesting are the days that were influenced by anthropogenic industrial emissions. Hattori *et al.* (2020) reported large enhancements in COS mixing ratios, accompanied by depleted  $\delta^{34}\text{S}$  values, when measuring air from the Chinese mainland. It is likely that in Europe there is less anthropogenic COS emission, but no measurements have been presented so far on these emissions nor has their sulfur isotopic composition been reported. On the 1<sup>st</sup> and 2<sup>nd</sup> of December, the Netherlands experienced mostly Easterly winds, bringing in polluted air from the Ruhr area, a large industrial region in Western Germany. COS data from these days are shown separately in Figure 8, together with  $\text{CH}_4$  and  $\text{CO}_2$  mixing ratios. During these days,  $\text{CO}_2$  and  $\text{CH}_4$  mixing ratios increased, with a maximum  $\text{CO}_2$  mixing ratio of 480 ppm and  $\text{CH}_4$  mixing ratio peaking at 2.5 ppb. During the first hours of this pollution accumulation, COS mixing ratios also increased from around 480 to 520 ppt at the maximum. The ratio  $\text{COS}/\text{CO}_2$  for these first four measurements was approximately 0.7 ppt/ppm. However, while during the evening of the 2<sup>nd</sup> of December both  $\text{CO}_2$  and  $\text{CH}_4$  mixing ratios continued to increase, COS mixing ratios decreased again to

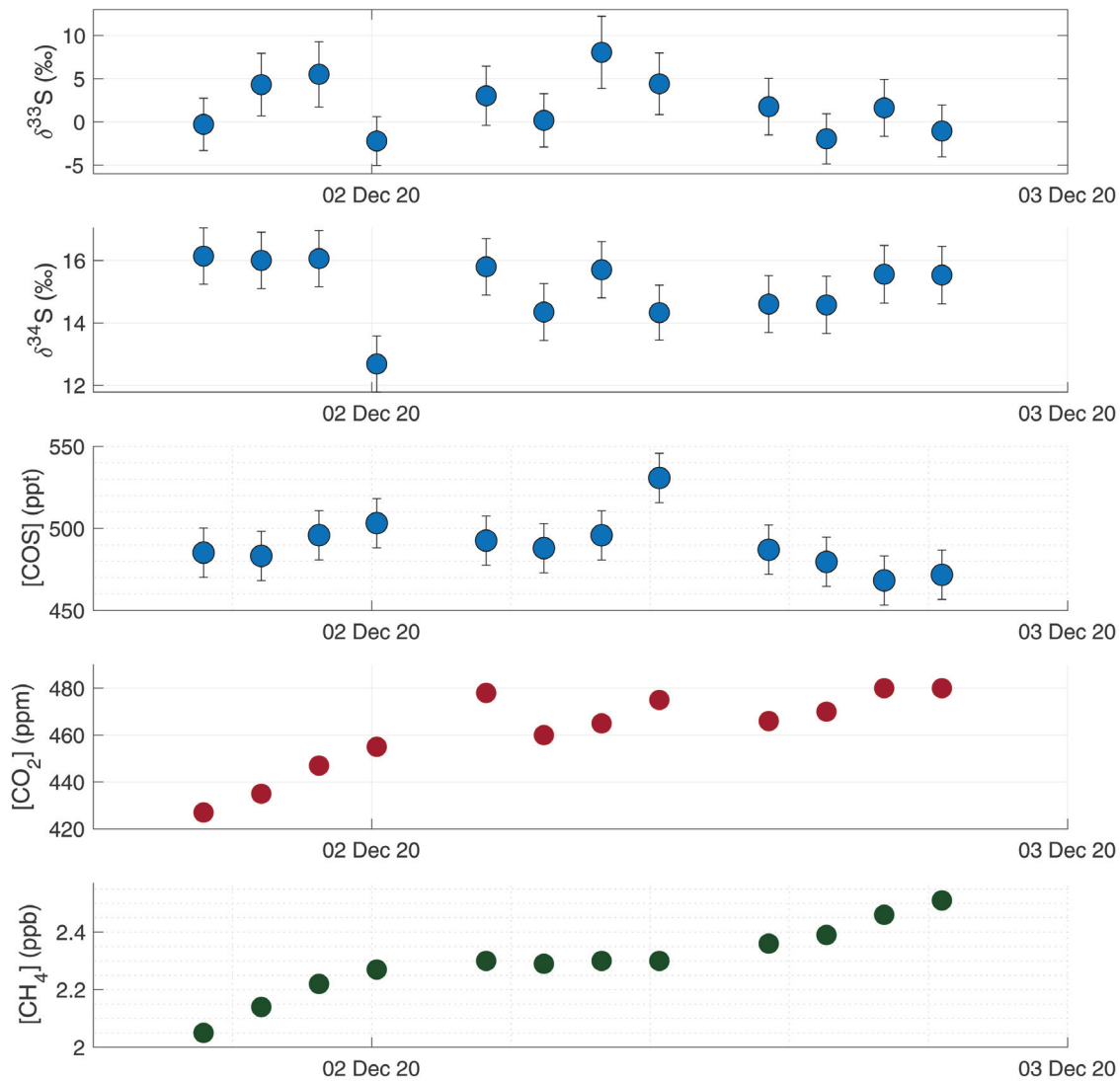

**Figure 8.** Results from a measurement sequence on the 1<sup>st</sup> and 2<sup>nd</sup> of December, during which a pollution plume advected from Germany was observed. Figures from high to low:  $\delta^{33}\text{S}$ ,  $\delta^{34}\text{S}$ , COS mixing ratio, CO<sub>2</sub> mixing ratio and CH<sub>4</sub> mixing ratio.

below 480 ppt. During this period, we see small variations in both  $\delta^{33}\text{S}$  and  $\delta^{34}\text{S}$ , with some depleted values for the highest mixing ratios, but the differences are generally small. Thus, while there was a large increase in both CO<sub>2</sub> and CH<sub>4</sub> mixing ratios, we did not observe a substantial increase in COS mixing ratio, nor was there a large trend in  $\delta^{33}\text{S}$  or  $\delta^{34}\text{S}$  values. We can therefore conclude that this pollution plume did not contain large amounts of COS, and this major industrial area in Germany may not contribute much to the global anthropogenic COS emissions. More generally, the impact of European anthropogenic emissions on the COS budget in the Netherlands is likely small, because we generally do not see events with high COS mixing ratios and/or very depleted values of  $\delta^{34}\text{S}$  during our measurement period. Looking at the gridded global anthropogenic inventory data of [Zumkehr \*et al.\* \(2018\)](#),

there is some emission visible in western Europe, and indeed also in the Ruhr area. However, when comparing the European anthropogenic COS emission to that of East Asia, there are fewer sources, and also lower COS emissions from these source locations. [Zumkehr \*et al.\* \(2018\)](#) also state in their paper that 45 % of the global anthropogenic COS emissions come from China, and the rest of the emissions are relatively evenly spread over India, North America and Europe. This would explain the absence of large COS enhancements during our measurement period compared to previous studies by [Hattori \*et al.\* \(2020\)](#), who measured enhancements in air originating from China.

Analysis of air origins through backward trajectory modelling provides insight into the regional sources and sinks of COS. The Netherlands is situated in the mid-latitudes and

receives air from very different origins, which can change the influence of different sources and sinks on the COS that we measure in Utrecht. When we for instance look at the data subset of the 23<sup>rd</sup> of October and compare it to the 28<sup>th</sup> of October, we see large differences in both COS mixing ratio and  $\delta$  values. The backward trajectories of these two days, indicated with pink (22 and 23 Oct) and green (28 Oct) in Figure 7, show that on Oct 23<sup>rd</sup>, the air came mostly from the South and travelled far over the continent across Spain and France at an altitude of just below 500 m, before reaching Utrecht. On Oct 28<sup>th</sup>, the air originated from the North and travelled mostly over the ocean at low altitude of mostly below 200 m, according to the HYSPLIT trajectories. On Oct 28<sup>th</sup> we see a lower and more stable COS mixing ratio of  $455 \pm 9.5$  ppt than on the 23<sup>rd</sup>, which had a mean mixing ratio of  $509 \pm 39$  ppt. On the 28<sup>th</sup>, we also observe high mean  $\delta$  values of  $5.3 \pm 3.3$  ‰ and  $18.9 \pm 1.2$  ‰ for  $\delta^{33}\text{S}$  and  $\delta^{34}\text{S}$  respectively. In contrast, on the 23<sup>rd</sup> we find mean  $\delta$  values of  $-2.7 \pm 3.1$  ‰ and  $14.0 \pm 1.2$  ‰ for  $\delta^{33}\text{S}$  and  $\delta^{34}\text{S}$  respectively. One explanation for these differences could be that on land there are more sources and sinks influencing COS (being biosphere uptake and anthropogenic emissions), which would create

more variability in the mixing ratio; a phenomenon we see on the 23<sup>rd</sup>. On the 28<sup>th</sup> we probably see a representation of rather clean background air, probably affected by ocean emissions, which is proposed to have a value of 19 ‰ (Angert *et al.*, 2019; Davidson *et al.*, 2021; Hattori *et al.*, 2020), which is higher than the background. Biosphere uptake in the higher latitudes could be a stable sink decreasing the mixing ratio and due to fractionation effects also making the COS more enriched in  $^{34}\text{S}$  (Davidson *et al.*, 2021). However, quantification of these sources and sinks requires more observations and the use of models.

To gain more insight into the processes influencing the COS from different air origins, the following data subsets were created: only northern air, only southern air and all “other directions” air. Relatively high mixing ratios were found in the northern air data subset, thus Keeling plots were created of the data subsets to assess whether there were any trends present and whether source signatures could be identified. As can be seen in Figure 9, a dependence of the  $\delta$  values on the mixing ratio can only be found for the northern air data. This Keeling plot shows a picture that is consistent with an isotopically depleted

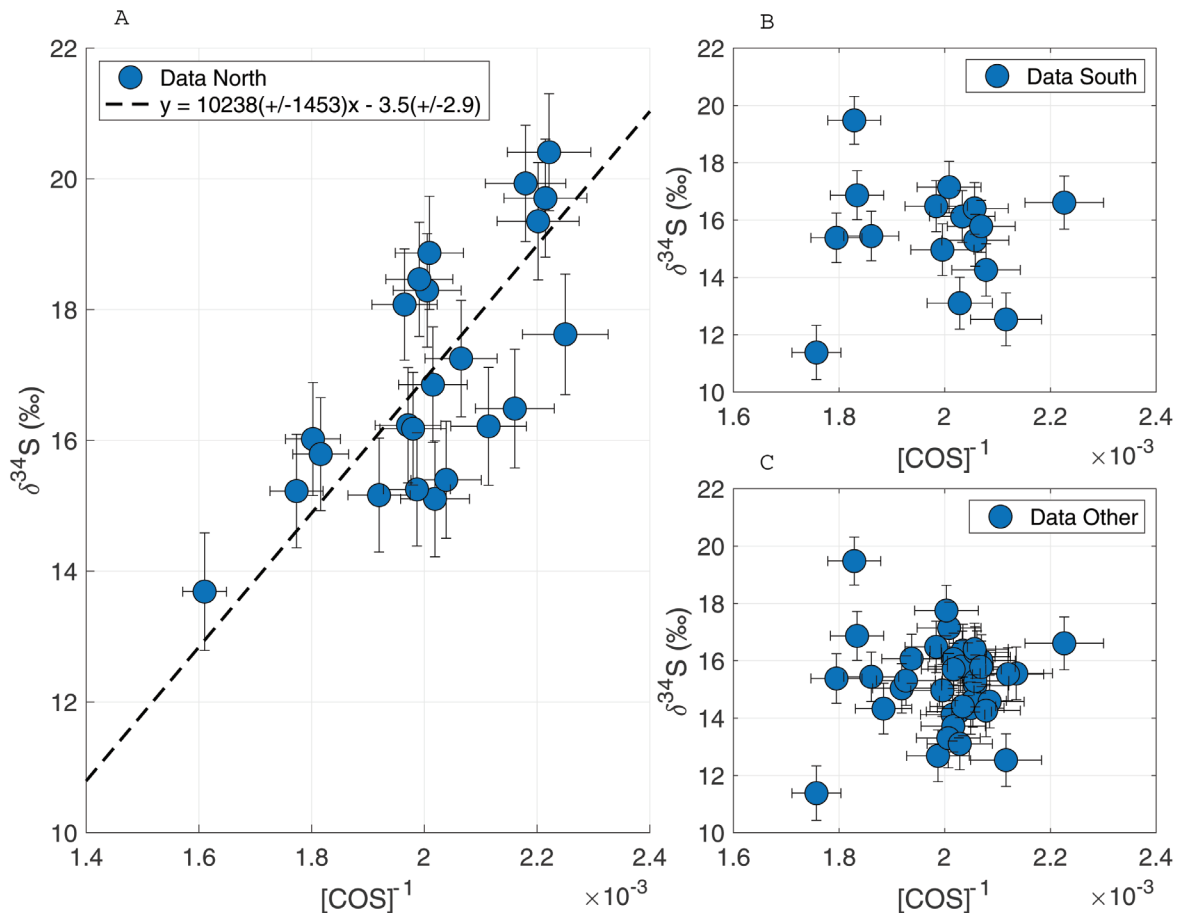

**Figure 9.** Keeling plots for  $\delta^{34}\text{S}$  for data subsets from different wind directions. **A:** wind direction from the North, **B:** wind direction from the South, **C:** all data excluding wind direction from the North.



COS source, with a Keeling plot intercept of  $-3.5 \pm 2.9$  ‰. A potential  $^{34}\text{S}$  depleted source could be anthropogenic COS, however, previous estimates of  $\delta^{34}\text{S}$  from anthropogenic COS were slightly higher than this Keeling intercept (Davidson *et al.*, 2021; Hattori *et al.*, 2020). While there are some large industrial areas in the North of the Netherlands, more local measurements are needed to confirm this rather depleted anthropogenic source. On the low concentration end of the Keeling plot, COS is enriched in  $^{34}\text{S}$ , which could be due to fractionation taking place during biosphere uptake in higher latitudes.

### Highway tunnel measurements

The highway tunnel dataset is available in *Underlying data* (Baartman *et al.*, 2021). While driving through the several tunnel tubes, the Picarro analyzers clearly measured an increase of  $\text{CO}_2$  from the entrance to the exit of the tunnel, indicating a build-up of exhaust gases inside all the tunnel tubes. The on-line  $\text{CO}_2$  mixing ratio data can be found in *Extended data* (Baartman *et al.*, 2021). Besides  $\text{CO}_2$ , no clear elevation of the other compounds ( $\text{CH}_4$  and  $\text{H}_2\text{O}$ ) was measured. From the total of six samples taken in the tunnel for COS measurements, two samples were not suitable for isotope measurements as they had too low pressure and therefore, we only report the results of four tunnel samples.

The results of our sample measurements show elevated COS mixing ratios in the tunnel, with a maximum increase of around 50 to 160 ppt compared to the background mixing ratio of 490 ppt. The maximum mixing ratio in a sample taken inside the tunnel was around  $650 \pm 15$  ppt. The  $\text{CO}_2$  mixing ratio in the samples was between 541 and 606 ppm. From these values we calculated the COS/ $\text{CO}_2$  enhancement ratio, which was  $0.4 \pm 0.08$  ppt/ppm for the first three samples and  $1.15 \pm 0.1$  ppt/ppm for the last sample. As the first three samples had such a consistent COS/ $\text{CO}_2$  ratio, we assumed that the fourth sample was possibly contaminated by a single high COS-emitting vehicle, and we excluded it from the ratio estimation. If we assume that this ratio of 0.4 ppt/ppm is typical for a European fleet, we can make a very rough estimate of the annual European COS emissions from road traffic. Using the annual  $\text{CO}_2$  emission from road transport (sector name 1.A.3b) for the year 2018 (European Environment Agency, 2020) of around 888 Tg  $\text{CO}_2$ , we find a COS emission of 0.19 Gg  $\text{S a}^{-1}$ . Earlier estimates of global COS emissions from road traffic are in the range of 0.8 – 8 Gg  $\text{S a}^{-1}$  (Chin & Davis, 1995; Fried *et al.*, 1992; Watts, 2000; Lee & Brimblecombe, 2016) with the most recent estimate being on the higher side of this range with  $6 \pm 4$  Gg  $\text{S a}^{-1}$  (Watts, 2000). Because the European Committee for Standardization (CEN) fuel content standard states a maximum sulfur content of only 10 ppm (EEA, 2003) since the year 2009, we consider 0.19 Gg  $\text{S a}^{-1}$  for Europe a reasonable estimate. However, as our calculated COS/ $\text{CO}_2$  ratio is only based on a small dataset, this can only be seen as a rough first estimate of European COS traffic emissions.

Figure 10 shows the Keeling plots for  $\delta^{33}\text{S}$  (left) and  $\delta^{34}\text{S}$  (right), with the four tunnel samples and the average background value  $\pm 1 \sigma$  uncertainty. A two-isotope plot of all the

ambient air data and the tunnel sample data can be found in *Extended data* (Baartman *et al.*, 2021). The COS in the tunnel samples is depleted in both  $^{33}\text{S}$  and  $^{34}\text{S}$  with a Keeling intercept of  $-71.5 \pm 21.2$  ‰ for  $\delta^{33}\text{S}$  and  $6.9 \pm 4.7$  ‰ for  $\delta^{34}\text{S}$ . In previous studies (Angert *et al.*, 2019; Davidson *et al.*, 2021; Hattori *et al.*, 2020), only the COS sulfur isotope ratios for total anthropogenic emissions have been reported, and a distinction between different anthropogenic sources has not been made thus far. The general trend of depleted values for  $\delta^{34}\text{S}$  for traffic emissions roughly agrees with the current estimate for the anthropogenic emission signature of 3 to 8 ‰. The very low Keeling plot intercept for  $\delta^{33}\text{S}$  of  $-71.5 \pm 21.2$  ‰ would indicate a strongly mass-independent process, which is unexpected, and it would be helpful to confirm this with additional studies. With the present evidence being based on only four samples, which were also processed slightly differently from ambient air (e.g. including a dilution step), we consider it premature to draw reliable conclusions. We note, however, that the sulfur in gasoline and diesel in Europe is highly modified by the complex sulfur removal process (Srivastava, 2012) to reduce the sulfur content from ‰ to ppm level (EEA, 2003), which could in principle lead to anomalous  $\delta^{33}\text{S}$  in fuel. If this low  $\delta^{33}\text{S}$  is confirmed, strong processing might explain the unexpected sulfur isotopic composition of the COS emissions, although the mass-independent fractionation processes involved are still unexplained.

### Conclusion

In this paper, we described a new measurement system for  $\delta^{33}\text{S}$  and  $\delta^{34}\text{S}$  in COS, developed at Utrecht University, which enables measurements of small samples, with a relatively simple GC-IRMS system. A single measurement only takes 2 to 3 hours. We obtained a total precision for 4 L ambient air samples of 2.4 ‰ for  $\delta^{33}\text{S}$  and 0.9 ‰ for  $\delta^{34}\text{S}$ , when including the error in the nonlinearity correction and the calibration. The ability to measure small samples allows us to measure air from a wide variety of locations, which will allow us to characterize latitudinal and altitudinal variations in COS isotopologues.

The sampling system coupled to the pre-concentration system can measure ambient air in Utrecht with little maintenance effort. This will enable us to create a long-term record of COS mixing ratio and isotopic composition in the Netherlands, which will help to gain more insight in the seasonal and year to year variability of COS. The first results from ambient air measurement in Utrecht show a small increase in COS mixing ratio of 40 ppt from fall to winter. During the measurement period, no mixing ratios higher than 620 ppt were observed and the mean  $\delta^{34}\text{S}$  of  $15.9 \pm 0.9$  ‰ was relatively high compared to previously reported results by Angert *et al.* (2019), Kamezaki *et al.* (2019), Hattori *et al.* (2020) and Davidson *et al.* (2021). This leads us to conclude that the air in Utrecht likely receives relatively little COS from anthropogenic sources.

Three out of four measurements of samples taken inside a highway tunnel yielded a COS/ $\text{CO}_2$  ratio of 0.4 ppt/ppm, which can be extrapolated into a European estimate of COS

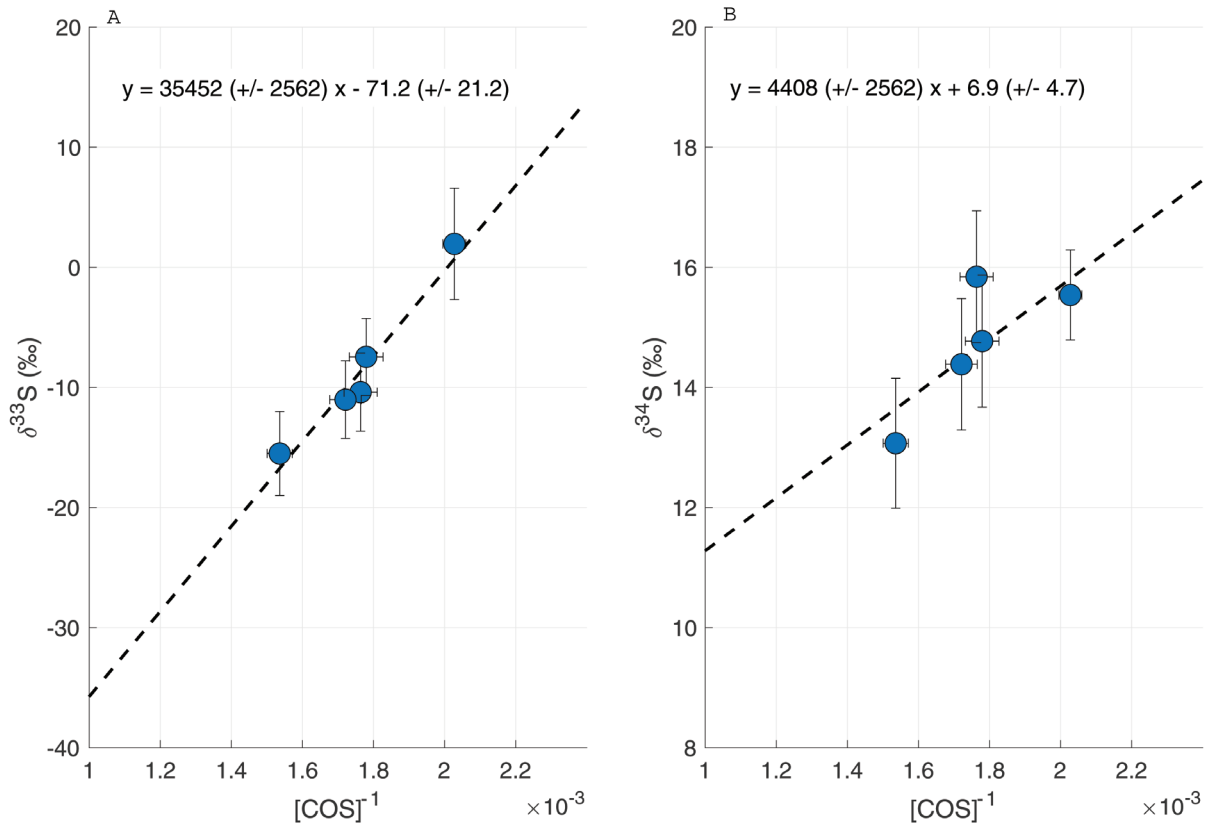

**Figure 10.** Keeling plot of the samples taken inside a highway tunnel, for  $\delta^{33}\text{S}$  (A) and  $\delta^{34}\text{S}$  (B).

from traffic emissions of  $0.19 \text{ Gg S a}^{-1}$ , which is in rough agreement with the current global estimates of COS emissions from traffic (Chin & Davis, 1995; Fried *et al.*, 1992; Lee & Brimblecombe, 2016; Watts, 2000). The derived value of  $\delta^{34}\text{S} = 6.9 \pm 4.7 \text{ ‰}$  of traffic emissions is close to the reported values for anthropogenic emissions (Angert *et al.*, 2019; Davidson *et al.*, 2021; Hattori *et al.*, 2020). The very low value of  $-71.5 \pm 21.2 \text{ ‰}$  for  $\delta^{33}\text{S}$  in COS from traffic is unexpected and further measurements would be helpful to confirm this value. However, COS emissions from traffic make only a small contribution to the overall budget. Thus, more effort is needed to reduce uncertainties in the dominating sources and sinks in the COS budget using isotopic analysis.

### Data availability

#### Underlying data

Zenodo: A GC-IRMS method for measuring sulfur isotope ratios of carbonyl sulfide from small air samples. <https://doi.org/10.5281/zenodo.6319758> (Baartman *et al.*, 2021).

This project contains the following underlying data:

- COS\_isotopes\_ambient\_air\_data\_Baartman\_et\_al.xlsx (dataset of ambient air measurements at Utrecht and highway tunnel).

- COS\_isotopes\_ambient\_air\_origin\_subsets\_data\_Baartman\_et\_al.xlsx (dataset of the created subsets based on air origin from HYSPLIT model analyses).
- COS\_isotopes\_nonlinearity\_test\_Baartman\_et\_al.xlsx.
- COS\_isotopes\_reproducibility\_Baartman\_et\_al.xlsx.
- COS\_isotopes\_target\_data\_Baartman\_et\_al.xlsx (target measurements dataset for the long-term stability).
- COS\_isotopes\_calibration\_data\_Baartman\_et\_al.xlsx (calibration data).
- HYSPLIT\_backward\_trajectories\_Baartman\_et\_al.zip (folder with results from HYSPLIT backward trajectory analyses including .txt files and generated figures in .pdf).

#### Extended data

Zenodo: A GC-IRMS method for measuring sulfur isotope ratios of carbonyl sulfide from small air samples. <https://doi.org/10.5281/zenodo.6319758> (Baartman *et al.*, 2021).

This project contains the following extended data:

- Supplementary\_figure1\_Baartman\_et\_al.eps

- Supplementary\_figure\_2\_Baartman\_et\_al.eps
- Supplementary\_figure3\_Baartman\_et\_al.eps

Data are available under the terms of the [Creative Commons Attribution 4.0 International license \(CC-BY 4.0\)](https://creativecommons.org/licenses/by/4.0/).

## References

- Angert A, Said-Ahmad W, Davidson C, *et al.*: **Sulfur isotopes ratio of atmospheric carbonyl sulfide constrains its sources.** *Sci Rep.* 2019; **9**(1): 741. [PubMed Abstract](#) | [Publisher Full Text](#) | [Free Full Text](#)
- Asaf D, Rotenberg E, Tatarinov F, *et al.*: **Ecosystem photosynthesis inferred from measurements of carbonyl sulphide flux.** *Nat Geosci.* 2013; **6**(3): 186–190. [Publisher Full Text](#)
- Baartman SL, Krol MC, Röckmann T, *et al.*: **A GC-IRMS method for measuring sulfur isotope ratios of carbonyl sulfide from small air samples.** (Version 1) [Data set]. Zenodo. 2021. <http://www.doi.org/10.5281/zenodo.5031605>
- Barkley MP, Palmer PI, Boone CD, *et al.*: **Global distributions of carbonyl sulfide in the upper troposphere and stratosphere.** *Geophys Res Lett.* 2008; **35**(14). [Publisher Full Text](#)
- Berry J, Wolf A, Campbell JE, *et al.*: **A coupled model of the global cycles of carbonyl sulfide and CO<sub>2</sub>: A possible new window on the carbon cycle.** *J Geophys Res Biogeosci.* 2013; **118**(2): 842–852. [Publisher Full Text](#)
- Blonquist JM Jr, Montzka SA, Munger JW, *et al.*: **The potential of carbonyl sulfide as a proxy for gross primary production at flux tower sites.** *J Geophys Res Biogeosci.* 2011; **116**(G4). [Publisher Full Text](#)
- Brühl C, Lelieveld J, Crutzen PJ, *et al.*: **The role of carbonyl sulphide as a source of stratospheric sulphate aerosol and its impact on climate.** *Atmos Chem Phys.* 2012; **12**(3): 1239–1253. [Publisher Full Text](#)
- Campbell JE, Carmichael GR, Chai T, *et al.*: **Photosynthetic control of atmospheric carbonyl sulfide during the growing season.** *Science.* 2008; **322**(5904): 1085–1088. [PubMed Abstract](#) | [Publisher Full Text](#)
- Chin M, Davis DD: **A reanalysis of carbonyl sulfide as a source of stratospheric background sulfur aerosol.** *J Geophys Res Atmos.* 1995; **100**(D5): 8993–9005. [Publisher Full Text](#)
- COSANOVA: **Materials to avoid.** 1995. (n.d.). [Reference Source](#)
- Crutzen PJ: **The possible importance of CSO for the sulfate layer of the stratosphere.** *Geophys Res Lett.* 1976; **3**(2): 73–76. [Publisher Full Text](#)
- Davidson C, Amrani A, Angert A: **Tropospheric carbonyl sulfide mass balance based on direct measurements of sulfur isotopes.** *Proc Natl Acad Sci U S A.* 2021; **118**(6): e2020060118. [PubMed Abstract](#) | [Publisher Full Text](#) | [Free Full Text](#)
- EastGrip (2018, 2021). Retrieved April 8, 2021. [Reference Source](#)
- European Environment Agency: **Directive 2003/17/EC of the European Parliament and of the Council, amending Directive 98/70/EC relating to the quality of petrol and diesel fuels.** Official Journal of the European Union, (L 76/10). 2003. [Reference Source](#)
- European Environment Agency: **National greenhouse gas inventories (IPCC Reporting Format sector classification) [Data file].** 2020. [Reference Source](#)
- Farquhar J, Wing BA: **Multiple sulfur isotopes and the evolution of the atmosphere.** *Earth Planet Sci Lett.* 2003; **213**(1–2): 1–13. [Publisher Full Text](#)
- Fried A, Henry B, Ragazzi RA, *et al.*: **Measurements of carbonyl sulfide in automotive emissions and an assessment of its importance to the global sulfur cycle.** *J Geophys Res-Atmos.* 1992; **97**(D13): 14621–14634. [Publisher Full Text](#)
- Glattthor N, Höpfner M, Leyser A, *et al.*: **Global carbonyl sulfide (OCS) measured by MIPAS/Envisat during 2002– 2012.** *Atmos Chem Phys.* 2017; **17**(4): 2631–2652. [Publisher Full Text](#)
- Hattori S, Danielache SO, Johnson MS, *et al.*: **Ultraviolet absorption cross sections of carbonyl sulfide isotopologues OC<sup>32</sup>S, OC<sup>33</sup>S, OC<sup>34</sup>S and O<sup>13</sup>CS: isotopic fractionation in photolysis and atmospheric implications.** *Atmos Chem Phys.* 2011; **11**(19): 10293–10303. [Publisher Full Text](#)
- Hattori S, Kamezaki K, Yoshida N: **Constraining the atmospheric OCS budget from sulfur isotopes.** *Proc Natl Acad Sci U S A.* 2020; **117**(34): 20447–20452. [PubMed Abstract](#) | [Publisher Full Text](#) | [Free Full Text](#)
- Hattori S, Schmidt JA, Mahler DW, *et al.*: **Isotope Effect in the Carbonyl Sulfide Reaction with O (<sup>3</sup>P).** *J Phys Chem A.* 2012; **116**(14): 3521–3526. [PubMed Abstract](#) | [Publisher Full Text](#)
- Hattori S, Toyoda A, Toyoda S, *et al.*: **Determination of the sulfur isotope ratio in carbonyl sulfide using gas chromatography/isotope ratio mass spectrometry on fragment ions <sup>32</sup>S<sup>+</sup>, <sup>33</sup>S<sup>+</sup>, and <sup>34</sup>S<sup>+</sup>.** *Anal Chem.* 2015; **87**(1): 477–484. [PubMed Abstract](#) | [Publisher Full Text](#)
- Kamezaki K, Hattori S, Bahlmann E, *et al.*: **Large-volume air sample system for measuring <sup>34</sup>S/<sup>32</sup>S isotope ratio of carbonyl sulfide.** *Atmos Meas Tech.* 2019; **12**(2): 1141–1154. [Publisher Full Text](#)
- Kamezaki K, Hattori S, Ogawa T, *et al.*: **Sulfur isotopic fractionation of carbonyl sulfide during degradation by soil bacteria.** *Environ Sci Technol.* 2016; **50**(7): 3537–3544. [PubMed Abstract](#) | [Publisher Full Text](#)
- Keeling CD: **The concentration and isotopic abundances of carbon dioxide in rural and marine air.** *Geochim Cosmochim Acta.* 1961; **24**(3–4): 277–298. [Publisher Full Text](#)
- Kettle AJ, Kuhn U, von Hobe M, *et al.*: **Global budget of atmospheric carbonyl sulfide: Temporal and spatial variations of the dominant sources and sinks.** *J Geophys Res-Atmos.* 2002; **107**(D22): ACH 25-1-ACH 25-16. [Publisher Full Text](#)
- Kooijmans LM, Uitslag NA, Zahniser MS, *et al.*: **Continuous and high-precision atmospheric concentration measurements of COS, CO<sub>2</sub>, CO and H<sub>2</sub>O using a quantum cascade laser spectrometer (QCLS).** *Atmos Meas Tech.* 2016; **9**(11): 5293–5314. [Publisher Full Text](#)
- Kremser S, Thomason LW, von Hobe M, *et al.*: **Stratospheric aerosol—Observations, processes, and impact on climate.** *Rev Geophys.* 2016; **54**(2): 278–335. [Publisher Full Text](#)
- Kuai L, Worden J, Kulawik SS, *et al.*: **Characterization of Aura TES carbonyl sulfide retrievals over ocean.** *Atmos Meas Tech.* 2014; **7**(1): 163–172. [Publisher Full Text](#)
- Lee CL, Brimblecombe P: **Anthropogenic contributions to global carbonyl sulfide, carbon disulfide and organosulfides fluxes.** *Earth Sci Rev.* 2016; **160**: 1–18. [Publisher Full Text](#)
- Lennartz ST, Marandino CA, von Hobe M, *et al.*: **Direct oceanic emissions unlikely to account for the missing source of atmospheric carbonyl sulfide.** *Atmos Chem Phys.* 2017; **17**(1): 385–402. [Publisher Full Text](#)
- Lennartz ST, Marandino CA, von Hobe M, *et al.*: **Marine carbonyl sulfide (OCS) and carbon disulfide (CS<sub>2</sub>): a compilation of measurements in seawater and the marine boundary layer.** *Earth Syst Sci Data.* 2020; **12**(1): 591–609. [Publisher Full Text](#)
- Ma J, Kooijmans LMJ, Cho A, *et al.*: **Inverse modelling of carbonyl sulfide: implementation, evaluation and implications for the global budget.** *Atmos Chem Phys Discuss.* 2021; **21**(5): 3507–3529. [Publisher Full Text](#)

## Acknowledgements

We are grateful for the technical support from Carina van der Veen, Henk Snellen, Marcel Portanger and Giorgio Cover. The authors gratefully acknowledge the NOAA Air Resources Laboratory for the provision of the HYSPLIT and dispersion model and/or READY website (<https://www.ready.noaa.gov>).

Maazallahi H, Fernandez JM, Menoud M, *et al.*: **Methane mapping, emission quantification, and attribution in two European cities: Utrecht (NL) and Hamburg (DE)**. *Atmos Chem Phys*. 2020; **20**(23): 14717–14740.

[Publisher Full Text](#)

Montzka SA, Calvert P, Hall BD, *et al.*: **On the global distribution, seasonality, and budget of atmospheric carbonyl sulfide (COS) and some similarities to CO<sub>2</sub>**. *J Geophys Res Atmos*. 2007; **112**(D9).

[Publisher Full Text](#)

National Institute of Standards and Technology: **Report of Investigation Reference Material 8554**. Gonzales, C.A., Watters, R.L. (Ed.), Gaithersburg, MD 20899, 2013.

[Reference Source](#)

Newman L, Krouse HR, Grinenko VA: **Sulphur isotope variations in the atmosphere**. In: *Stable Isotopes: Natural and anthropogenic sulphur in the environment*. SCOPE (eds. H.R. Krouse & V.A. Grinenko) John Wiley & Sons, 1991.

[Reference Source](#)

NIST Mass Spectrometry Data Center, Wallace WE: **Mass Spectra**. P.J. Linstrom and W.G. Mallard (Ed.), *NIST Chemistry WebBook*. Standard Reference Database Number 69. National Institute of Standards and Technology, Gaithersburg MD, 20899, (retrieved April 8, 2021).

Ogawa T, Hattori S, Kamezaki K, *et al.*: **Isotopic fractionation of sulfur in carbonyl sulfide by carbonyl sulfide hydrolase of *Thiobacillus thioparus* THI115**. *Microbes Environ*. 2017; **32**(4): 367–375.

[PubMed Abstract](#) | [Publisher Full Text](#) | [Free Full Text](#)

Ono S, Wing B, Rumble D, *et al.*: **High precision analysis of all four stable isotopes of sulfur (<sup>32</sup>S, <sup>33</sup>S, <sup>34</sup>S and <sup>36</sup>S) at nanomole levels using a laser fluorination isotope-ratio-monitoring gas chromatography-mass spectrometry**. *Chem Geol*. 2006; **225**(1–2): 30–39.

[Publisher Full Text](#)

Pataki DE, Ehleringer JR, Flanagan LB, *et al.*: **The application and interpretation of Keeling plots in terrestrial carbon cycle research**. *Global Biogeochem Cycles*. 2003; **17**(1).

[Publisher Full Text](#)

Protoschill-Krebs G, Kesselmeier J: **Enzymatic pathways for the consumption of carbonyl sulphide (COS) by higher plants**. *Botanica Acta*. 1992; **105**(3): 206–212.

[Publisher Full Text](#)

Protoschill-Krebs G, Wilhelm C, Kesselmeier J: **Consumption of carbonyl sulphide (COS) by higher plant carbonic anhydrase (CA)**. *Atmospheric Environment*. 1996; **30**(18): 3151–3156.

[Publisher Full Text](#)

Rijkswaterstaat: **Leidsche Rijntunnel (A2)**. 2020.

[Reference Source](#)

Rothe M, Jordan A, Brand WA, *et al.*: **Trace gases, δ13C and δ18O of CO<sub>2</sub>-in-**

**air samples: Storage in glass flasks using PCTFE seals and other effects**. Proceedings of the 12th IAEA/WMO meeting of CO<sub>2</sub> experts, Toronto, Sept. 2003, WMO-GAW Report 161, ed. D. Worthy and L. Huang. 2005; 64–70.

Schmidt JA, Johnson MS, Jung Y, *et al.*: **Predictions of the sulfur and carbon kinetic isotope effects in the OH + OCS reaction**. *Chem Phys Lett*. 2012; **531**: 64–69.

[Publisher Full Text](#)

Srivastava VC: **An evaluation of desulfurization technologies for sulfur removal from liquid fuels**. *RSC Adv*. 2012; **2**(3): 759–783.

[Publisher Full Text](#)

Stein AF, Draxler RR, Rolph GD, *et al.*: **NOAA's HYSPLIT atmospheric transport and dispersion modeling system**. *Bull Amer Meteor Soc*. 2015; **96**(12): 2059–2077.

[Publisher Full Text](#)

Stinecipher JR, Cameron-Smith PJ, Blake NJ, *et al.*: **Biomass burning unlikely to account for missing source of carbonyl sulfide**. *Geophys Res Lett*. 2019; **46**(24): 14912–14920.

[Publisher Full Text](#)

Suntharalingam P, Kettle AJ, Montzka SM, *et al.*: **Global 3-D model analysis of the seasonal cycle of atmospheric carbonyl sulfide: Implications for terrestrial vegetation uptake**. *Geophys Res Lett*. 2008; **35**(19).

[Publisher Full Text](#)

Tangerman A: **Determination of volatile sulphur compounds in air at the parts per trillion level by Tenax trapping and gas chromatography**. *J Chromatogr*. 1986; **366**: 205–216.

[PubMed Abstract](#) | [Publisher Full Text](#)

Watts SF: **The mass budgets of carbonyl sulfide, dimethyl sulfide, carbon disulfide and hydrogen sulfide**. *Atmos Environ*. 2000; **34**(5): 761–779.

[Publisher Full Text](#)

Whelan ME, Lennartz ST, Gimeno TE, *et al.*: **Reviews and syntheses: Carbonyl sulfide as a multi-scale tracer for carbon and water cycles**. *Biogeosciences*. 2018; **15**(12): 3625–3657.

[Publisher Full Text](#)

York D, Evensen NM, Martinez ML, *et al.*: **Unified equations for the slope, intercept, and standard errors of the best straight line**. *Am J Phys*. 2004; **72**(3): 367–375.

[Publisher Full Text](#)

Yousefi M, Bernath PF, Boone CD, *et al.*: **Global measurements of atmospheric carbonyl sulfide (OCS), OC<sup>34</sup>S and O<sup>13</sup>CS**. *J Quant Spectrosc Radiat Transf*. 2019; **238**: 106554.

[Publisher Full Text](#)

Zumkehr A, Hilton TW, Whelan M, *et al.*: **Global gridded anthropogenic emissions inventory of carbonyl sulfide**. *Atmos Environ*. 2018; **183**: 11–19.

[Publisher Full Text](#)

# Open Peer Review

Current Peer Review Status:  

---

## Version 1

Reviewer Report 27 October 2021

<https://doi.org/10.21956/openreseurope.14959.r27824>

© 2021 Keeling R. This is an open access peer review report distributed under the terms of the [Creative Commons Attribution License](#), which permits unrestricted use, distribution, and reproduction in any medium, provided the original work is properly cited.



**Ralph Keeling** 

Geosciences Research Division, Scripps Institution of Oceanography, University of California, San Diego, San Diego, CA, USA

This study describes a method for measuring changes in the isotopic composition of sulfur in atmospheric carbonyl sulfide (COS) and applies it to a few preliminary investigations. The method topic is skillfully introduced, the method mostly is described in admirable detail. I expect the method and preliminary results will be of general interest to the community working on COS and related measurements.

I answered “partly” to the earlier question about data sources only because I did not try to fully assess the completeness of the supplemental data. For this study, readers will be most interested in reproducing the experimental method, not the calculations.

I have only minor suggestions for improvement. As the submitted manuscript lacked line numbers, I've resorted to cutting a pasting from the text:

- “Direct measurements of GPP are difficult to obtain, because flux measurements only yield the sum the two almost cancel-ling fluxes: GPP and respiration.” Needs to mention CO<sub>2</sub> fluxes.
- “The sulfur isotope ratios are reported as a  $\delta$  values” Cut “a”.
- “Newman et al. (1991) presented the first global estimate of 34S in tropospheric COS of 11 ‰.” – The absolute value of 11 ‰ is ambiguous without a discussion of the standard used in Eq. (2). Could be fixed by mention the standard earlier when presenting Eq. (2).
- “The destruction reaction of COS with hydrogen oxide radicals (OH)” - Aren't these more normally called hydroxyl radicals?
- “In short, the sample gas is first directed through a cooled Tenax trap..” I missed an explanation of why two cold traps at different temperature are needed. Why doesn't the

first trap achieve adequate focusing? Something to do with the materials in the trap and ability to warm quickly?

- “After all the sample gas is injected” Context is not clear here. Injected where? What triggers stopping the sample flow?
- Figure 2: I see four peaks on the left, not three, so the caption is confusing. Are we to ignore the first peak? For clarity, I suggest labeling the peaks: O<sub>2</sub>, CO<sub>2</sub>?, COS, organics?
- “Calibration” Section starting page 6: Despite the detail in this section, I struggled to get a clear understanding of how Utrecht scale is traced to VCDT. A clear description of tank assignments and hierarchy is missing. I understand the path somehow went through the Tokyo Institute of Technology. But how did they assign values to the COS samples? The paragraph that starts “The  $\delta^{34}\text{S}$  values on the CVDT scale were assigned...” is vague on what tanks are being assigned through this process. If the assignments were done in Tokyo, why do they need to be reassigned in Utrecht? I suggest adding a table which lists the tanks, their COS concentrations, and how they were assigned, e.g. treated as primaries (from Tokyo) or secondaries (assigned in Utrecht).
- Eq. (3). I’m not sure I see the point of calculating  $\sigma_{\text{total}}$ . Typically two types of error are relevant: How well can individual measurements be related to an internal lab scale? How well can the lab scale be related to scales in other labs? These two types of error require keeping  $\sigma_{\text{cal}}$  distinct from the other two errors. Also, the quantity  $\sigma_{\text{system}}$  was not clearly defined. Same as the “reproducibility” cited earlier?
- “Data corrections, quality check and long-term stability”. I was left without an understanding of the point at which the blank correction might have become problematic. Isn’t 5% already a bit large?
- “A target cylinder (5 L, dried ambient air filled in Greenland in 2017) was measured approximately weekly to monitor the long-term stability of the isotope measurements”. This sentence punctuates a break in the narrative thread. New paragraph, with a topic sentence?
- “The trapping efficiency was found to be 100 % for all injected volumes that were tested”. I’d have expected this to have uncertainty. May be expressed as greater than, as in > 99% or > 99.9%.
- “CO<sub>2</sub> interference was specifically tested since it was suspected to be one of the larger peaks on the chromatogram and since its possible interference was also mentioned by Angert et al. (2019).” Wouldn’t this test have been sufficient to positively identify the CO<sub>2</sub> peak on the chromatograph? If so, why did the earlier discussion suggest that this peak assignment was only tentative?
- Eq. (4) and (5). I’m unclear on why it is relevant to present functional fits to these data. Also, the data alone are not precise enough establish the exponential form. Why was this form chosen? Why not an inverse square root or other power law?
- Table 1. I don’t understand why the  $\delta^{34}\text{S}$  values from Utrecht differ so much from the

values in Japan. Does Utrecht keep a different  $\delta S_{34}$  standard? I presume this is related to the delta value relative to the instrument standard. But this is not set out clearly. It might help to create another symbol for this other scale, such as  $\delta_{\text{internal}}$ . This is related to the point above about scale traceability.

- “we made sure always to measure a 3L zero air injection after a measurement of a gas ..”  
The blank correction sensibly depends only on what was measured before, not after a sample.

**Is the rationale for developing the new method (or application) clearly explained?**

Yes

**Is the description of the method technically sound?**

Yes

**Are sufficient details provided to allow replication of the method development and its use by others?**

Yes

**If any results are presented, are all the source data underlying the results available to ensure full reproducibility?**

Partly

**Are the conclusions about the method and its performance adequately supported by the findings presented in the article?**

Yes

**Competing Interests:** No competing interests were disclosed.

**Reviewer Expertise:** Measurements of CO<sub>2</sub> and related atmospheric species.

**I confirm that I have read this submission and believe that I have an appropriate level of expertise to confirm that it is of an acceptable scientific standard.**

Author Response 02 Mar 2022

**Sophie Baartman**, Institute for Marine and Atmospheric research Utrecht (IMAU), Utrecht University, Utrecht, The Netherlands

Thank you for the kind and very useful review. See below for our responses to the comments, questions and suggestions.

- “Direct measurements of GPP are difficult to obtain, because flux measurements only yield the sum the two almost cancel-ling fluxes: GPP and respiration.” Needs to mention CO<sub>2</sub> fluxes.

This has now been added.

- “The sulfur isotope ratios are reported as a  $\delta$  values” Cut “a”.

This has been changed.

- *“Newman et al. (1991) presented the first global estimate of  $\delta^{34}\text{S}$  in tropospheric COS of 11 ‰.” – The absolute value of 11 ‰ is ambiguous without a discussion of the standard used in Eq. (2). Could be fixed by mention the standard earlier when presenting Eq. (2).*

The international standard VCDT is now mentioned already when introducing the  $\delta$  value calculation and the full name mention of the VCDT has been removed from the method section.

- *“The destruction reaction of COS with hydrogen oxide radicals (OH)” - Aren't these more normally called hydroxyl radicals?*

Indeed. This has been changed now.

- *“In short, the sample gas is first directed through a cooled Tenax trap..” I missed an explanation of why two cold traps at different temperature are needed. Why doesn't the first trap achieve adequate focusing? Something to do with the materials in the trap and ability to warm quickly?*

An additional explanation is added later on in the paragraph where the pre-concentration system is described in more detail: “This second cold trap is used to collect and release all the COS at the same time, creating a narrower peak on the chromatograph than if only the first cold trap, which heats up slower, would be used.”

- *“After all the sample gas is injected” Context is not clear here. Injected where? What triggers stopping the sample flow?*

This sentence was indeed unclear. It is now changed into: “After the desired volume of sample gas is injected in the Tenax trap, the collected gas is released from the Tenax by heating the trap to 130 °C with a heating wire.”

- *Figure 2: I see four peaks on the left, not three, so the caption is confusing. Are we to ignore the first peak? For clarity, I suggest labeling the peaks: O<sub>2</sub>, CO<sub>2</sub>?, COS, organics?*

The smaller peak at the beginning of the chromatograph is indeed also O<sub>2</sub> and is present because we constantly flush the IRMS source with O<sub>2</sub> in between measurements. There is now an added sentence in the text explaining this: “Because the IRMS source is constantly flushed with O<sub>2</sub> in between measurements, we also see half a peak of O<sub>2</sub> at the beginning of the chromatograph.”. Some changes on figure 2 were already suggested by another reviewer. The inset is enlarged in the new version and labels for the peaks are now also added.

- *“Calibration” Section starting page 6: Despite the detail in this section, I struggled to get a clear understanding of how Utrecht scale is traced to VCDT. A clear description of tank assignments and hierarchy is missing. I understand the path somehow went through the Tokyo Institute of Technology. But how did they assign values to the COS samples? The paragraph that starts “The  $\delta^{34}\text{S}$  values on the VCDT scale were assigned...” is vague on what tanks are being assigned through this process. If the assignments were done in Tokyo, why do they need to be reassigned in Utrecht? I suggest adding a table which lists the tanks, their COS concentrations, and how they were assigned, e.g. treated as primaries (from Tokyo) or secondaries (assigned in Utrecht).*

The calibration process was indeed a bit complicated and therefore not easy to describe. Four calibration gases were produced in Japan, and their  $\delta^{34}\text{S}$  values on the VCDT scale were calculated using the two methods described in the second paragraph of the calibration section (on-line and off-line method). Thus, these are our primary gases. These gases were then shipped to Utrecht and used to construct a calibration for the measurements on our IRMS. We have our own reference gas (the normal air cylinder from Greenland) which we calculated all our samples relatively to. Using the calibration gases



from Japan, we constructed a calibration curve (figure 5) in which we plot the d33S\_VCDT and d34S\_VCDT against the d33S and d34S as measured in Utrecht (relatively to our own reference gas). This calibration curve was then used to assign a value on the VCDT scale to our reference gas, which is then used to calculate the VCDT values of measured samples. The synthetization and calibration procedure of the primary gases, performed at the Tokyo Institute for Technology is described in Hattori *et al.* (2015) and is therefore not described in this paper in much detail. We tried to reformulate the methods section on the calibration slightly so that it is a bit clearer. Table 1 contains all the isotope values from the measurements in Utrecht (calculated against our reference gas) and the ones performed in Japan on the VCDT scale. As we wanted to keep the results and methods separated, the table is in the calibration results section.

- *Eq. (3). I'm not sure I see the point of calculating  $\sigma_{total}$ . Typically two types of error are relevant: How well can individual measurements be related to an internal lab scale? How well can the lab scale be related to scales in other labs? These two types of error require keeping  $\sigma_{cal}$  distinct from the other two errors. Also, the quantity  $\sigma_{system}$  was not clearly defined. Same as the "reproducibility" cited earlier?*

You are right. After some thinking from our side about our error propagation we indeed decided to make a difference between the error of our measurement system (how well our measurements can be related to our internal lab scale) and the calibration error, which represents how well our measurements can be related to the international VCDT scale. This has now been changed in the text and equation 3 has been adjusted to only include the reproducibility error and the nonlinearity error, which together make up our internal error. Because we are no longer incorporating the calibration error into the total reported error on individual measurements, the error for  $\delta^{33}\text{S}$  decreased slightly from 3.3‰ to 2.5‰ (see abstract). For  $\delta^{34}\text{S}$  it did not make a difference.

- *"Data corrections, quality check and long-term stability". I was left without an understanding of the point at which the blank correction might have become problematic. Isn't 5% already a bit large?*

The blank correction is not problematic. We use a blank correction to account for the "background" that is always in our system and therefore also in the sample measurements. This blank must be subtracted from the raw data in order to estimate the correct values of the samples. For this purpose, we need to determine the magnitude and stability of the blank.

- *"A target cylinder (5 L, dried ambient air filled in Greenland in 2017) was measured approximately weekly to monitor the long-term stability of the isotope measurements". This sentence punctuates a break in the narrative thread. New paragraph, with a topic sentence?*

Yes indeed, good point. This has now been changed into a new paragraph and the first sentence has been altered slightly.

- *"The trapping efficiency was found to be 100 % for all injected volumes that were tested". I'd have expected this to have uncertainty. May be expressed as greater than, as in > 99% or > 99.9%.*

This has now been changed into >99%, since indeed the uncertainty was not taken into account when mentioning the 100% trapping efficiency.

- *"CO<sub>2</sub> interference was specifically tested since it was suspected to be one of the larger peaks on the chromatogram and since its possible interference was also mentioned by Angert *et al.* (2019)." Wouldn't this test have been sufficient to positively identify the CO<sub>2</sub>*

*peak on the chromatograph? If so, why did the earlier discussion suggest that this peak assignment was only tentative?*

This section actually describes testing the possible effect of different substances being present in the gas mixture on the trapping efficiency of COS on the Tenax. Since Tenax also traps a small amount of CO<sub>2</sub> on its surface, one might expect an interference on the trapping of COS if there are large amounts of CO<sub>2</sub> present in a gas mixture. However, we did not see this interference and nor did Angert *et al.* (2019). This is a different interference than a possible overlapping of the peaks on the chromatograph, which we also checked.

- *Eq. (4) and (5). I'm unclear on why it is relevant to present functional fits to these data. Also, the data alone are not precise enough establish the exponential form. Why was this form chosen? Why not an inverse square root or other power law?*

The exponential function was chosen because this was the best fit for the data. We needed to have a continuous function in order to calculate the reproducibility for all the data. For the range of the ambient air measurement data of between 0.6 and 0.8 Vs, it does not matter that much which function was chosen. The estimate of the reproducibility will also improve as we will continue to gather more data.

- *Table 1. I don't understand why the d34S values from Utrecht differ so much from the values in Japan. Does Utrecht keep a different dS34 standard? I presume this is related to the delta value relative to the instrument standard. But this is not set out clearly. It might help to create another symbol for this other scale, such as delta\_internal. This is related to the point above about scale traceability.*

The d34S values of Japan are the values calibrated to the VCDT scale. The d34S values of Utrecht presented in this table are calculated relatively to our reference gas, which is the Greenland air cylinder. Thus, these d34S Utrecht values are not on the VCDT scale yet. We used the measurements in Japan to calibrate our measurements to the VCDT scale. We have this table in our paper to present the values used for the calibration line shown in figure 5. In figure 5 we use the d34S Utrecht and the d34S\_VCDT off-line (done in Japan) to calibrate d34S. This could indeed be made clearer in this table, so we now changed d34S Utrecht into d34S\_ref-Utrecht and d33S Utrecht into d33S\_ref-Utrecht

- *"we made sure always to measure a 3L zero air injection after a measurement of a gas .." The blank correction sensibly depends only on what was measured before, not after a sample.*

This is true. This sentence was not clear. What we meant was that we measured a zero air gas after a high mixing ratio sample in order to minimize the memory effect on the next sample measurement. This sentence has now been changed to make this clear: "However, we made sure to always measure a 3 L zero air injection after a measurement of a gas with higher COS mixing ratio, in order to minimize a potential memory effect on the subsequent measurement."

**Competing Interests:** No competing interests were disclosed.

Reviewer Report 15 October 2021

<https://doi.org/10.21956/openreseurope.14959.r27642>

© 2021 Lennartz S. This is an open access peer review report distributed under the terms of the [Creative Commons Attribution License](#), which permits unrestricted use, distribution, and reproduction in any medium, provided the original work is properly cited.



### Sinikka Lennartz

ICBM-MPI Bridging Group for Marine Geochemistry, Institute for Chemistry and Biology of the Marine Environment, University of Oldenburg, Oldenburg, Germany

The article by Baartman *et al.* describes a new method to measure the isotope ratios of sulphur in the trace gas carbonyl sulphide (COS) in ambient air samples. The motivation is laid out clearly, and the improvement of being able to measure low sample volumes reliably is an important one. The authors describe in detail the set-up and the results of various tests they performed to ensure the stability of the system and the absence of contamination. The latter is crucial for any system measuring COS, as many materials have been identified as a source of contamination previously. In addition to the description of the measurement system, the authors also apply the new technique to ambient air samples of different origin (ambient air at Utrecht, tunnel system) and report new COS isotope data that is of scientific relevance. I especially acknowledge the great level of detail given to describing the performed tests, the system and the preparation of standard gases. The paper is clearly structured and well written. I recommend this article for indexing, after some minor comments have been addressed, which I include in the following.

#### Abstract:

- The causality between 620 ppt (i.e. elevated COS mixing ratio) and the origin (i.e. not from anthropogenic emissions) was not clear to me – in the main text, you support the origin mainly by the high isotopic ratio, not by the high concentration. I suggest to rewrite the sentence.
- Strictly speaking, “40 ppt” is not a trend, as a trend should relate to a time unit. Can you say 40 ppt over 3 months or sth, to make it more clear?

#### Introduction:

- First paragraph: COS is the main source to stratospheric aerosols in volcanically quiescent periods only. I would suggest rewriting as “a major source” or “the main source in the absence of volcanic eruptions”.
- Paragraph 2: Consider citing some of the work by Protoschill-Krebs 1992/1996 to give credit to their work on how COS is taken up by plants, in addition to the review by Whelan *et al.*, 2018.

#### Methods:

- Fig. 2: I would suggest changing the size of the two panels: the close-up on the OCS peaks seems to me the most interesting one, and the one with the other peaks could be the smaller one.
- The sentence “The presence of scale contraction was checked by looking at the slope of the calibration line” and the following one could be revised to “A slope of the calibration line  $>1$  was considered as an evidence of scale contraction, and a correction method was developed.”

- Reference COSANOVA, n.d.: I would suggest putting the link directly in the text.
- In the section on Data corrections: You state some data that are clearly outliers were not included into the final dataset. Can you roughly give an estimate how often such outlier occur?
- When you describe the “Additional tests” in the method sections, you already give some results there. I would suggest moving that to the results section, to let the reader find the information he or she looks for where it is expected.
- Highway tunnel measurements: You already state in the text that the CO<sub>2</sub> concentration increases throughout the tunnel due to accumulation, but the canister for COS is mainly filled at the beginning. Assuming COS and CO<sub>2</sub> concentrations are correlated in the tunnel (which is safe to assume if both have traffic emissions as their main source), what does that mean for the COS:CO<sub>2</sub> ratio that you give? Is the resulting ratio rather a lower limit for the COS:CO<sub>2</sub> ratio?

## Results

- Fig. 3: the curve for d33S seems to strongly depend on the point at 0.4 Vs. Any idea on what causes this outlier, which is also a “low outlier” for d34S? Can you say sth on how consistent this pattern with this one outlier at 0.4 Vs is? How different is the fitted curve if the one at 0.4 Vs is omitted?
- Fig 3 caption/text: Method and caption say n=7-8, but text says n=6-8, please correct appropriately.
- To show the reproducibility (precision), I would have expected to see a figure with all individual data points. In the method section you state that reproducibility is tested by having 1L, 2L and 3L in 7-8 repetitions for two gases. I would suggest showing this in detail.
- Nonlinearity: You state that the nonlinearity is small and that only a small correction was needed. I may be missing sth here, but which correction did you actually apply? Can you give the exact equation?
- Can you describe why the scatter is so different for d34S and d33S in Fig. 4 and especially Fig. 5?
- Fig 6: It is good to be transparent about the second canister as a replacement after the first one was exhausted, and you state that clearly in the methods. For increasing the visibility of the plot, I suggest writing in the caption that both target gases are designed to be comparable, i.e. should have the same concentration. At least to me, this was confusing at the first look because they have different colors, so I had to go back to the method section to check what the difference between the two gases is.
- Measurements in Utrecht: “More generally, European anthropogenic COS emissions in the Netherlands are likely small” – I think I understand what you mean, but the sentence needs revising. Maybe: “More generally, the impact of European anthropogenic COS emissions in the Netherlands are likely small”. Still, how do you explain the increase in mixing ratio of COS that seemed to decrease again when CO<sub>2</sub> and CH<sub>4</sub> mixing ratios were still high?

- Conclusion: could you compare the errors to the errors of the previous methods? What is the final take on the trade-off between sample volume and uncertainty compared to the other methods?

I confirm that the links for underlying and extended data are working, and the data is fully accessible. I randomly checked some of the files and realised that e.g. in COS\_isotopes\_ambient\_air\_data\_Baartman\_et\_al.xlsx, the units are missing (while they are present in other files). It becomes clear from the context that it must be ppt, but would be helpful to add units for non COS-experts.

**Is the rationale for developing the new method (or application) clearly explained?**

Yes

**Is the description of the method technically sound?**

Yes

**Are sufficient details provided to allow replication of the method development and its use by others?**

Partly

**If any results are presented, are all the source data underlying the results available to ensure full reproducibility?**

Yes

**Are the conclusions about the method and its performance adequately supported by the findings presented in the article?**

Yes

**Competing Interests:** No competing interests were disclosed.

**Reviewer Expertise:** Marine carbonyl sulfide cycling, measurement of carbonyl sulfide via integrated cavity output spectroscopy, global budget of carbonyl sulfide

**I confirm that I have read this submission and believe that I have an appropriate level of expertise to confirm that it is of an acceptable scientific standard.**

Author Response 02 Mar 2022

**Sophie Baartman**, Institute for Marine and Atmospheric research Utrecht (IMAU), Utrecht University, Utrecht, The Netherlands

Thank you for the very kind review and the useful comments, suggestions, and questions. See below for our responses.

Abstract

- *The causality between 620 ppt (i.e. elevated COS mixing ratio) and the origin (i.e. not from anthropogenic emissions) was not clear to me – in the main text, you support the origin*

*mainly by the high isotopic ratio, not by the high concentration. I suggest to rewrite the sentence.*

The sentence is now rewritten to include the relatively high isotope ratio.

- *Strictly speaking, "40 ppt" is not a trend, as a trend should relate to a time unit. Can you say 40 ppt over 3 months or sth, to make it more clear?*

The sentence is changed.

### Introduction

- *First paragraph: COS is the main source to stratospheric aerosols in volcanically quiescent periods only. I would suggest rewriting as "a major source" or "the main source in the absence of volcanic eruptions".*

Good point. It is now added to the sentence.

- *Paragraph 2: Consider citing some of the work by Protoschill-Krebs 1992/1996 to give credit to their work on how COS is taken up by plants, in addition to the review by Whelan et al., 2018.*

Both papers are added to the citation and to the reference list.

### Methods

- *Fig. 2: I would suggest changing the size of the two panels: the close-up on the OCS peaks seems to me the most interesting one, and the one with the other peaks could be the smaller one.*

The figure is now changed. The one with all the peaks is still the larger one because I wanted to also be able to show the entire chromatograph well, with the square peaks. But now the inset is much larger and the thickness of the lines and the font there are also changed to make it all more visible and readable.

- *The sentence "The presence of scale contraction was checked by looking at the slope of the calibration line" and the following one could be revised to "A slope of the calibration line >1 was considered as an evidence of scale contraction, and a correction method was developed."*

Good suggestion. The sentence is changed into: "A slope of the calibration line >1 was considered as an evidence of scale contraction and, if needed, a correction method was developed."

- *Reference COSANOVA, n.d.: I would suggest putting the link directly in the text.*

I suggested to the editors to include the link to the website directly in the text instead of in the reference list.

- *In the section on Data corrections: You state some data that are clearly outliers were not included into the final dataset. Can you roughly give an estimate how often such outlier occur?*

I checked the last 300 measurements (including zero air and reference gas measurements), of which 7% were flagged due to the various reasons mentioned in the paper (error in pre-concentration, outlier due to other reasons). A sentence was included in this section that mentions the occurrence of outliers that were flagged.

- *When you describe the "Additional tests" in the method sections, you already give some results there. I would suggest moving that to the results section, to let the reader find the information he or she looks for where it is expected.*

The results of this section used to be in an appendix to the paper as we thought they did

not necessarily have to be included in the main results of the paper. From the editor, we received the suggestion to include these results already in the methods section. We think this is more convenient than adding another paragraph to the results section. Also when one wants to reproduce the methods they can immediately find the outcomes of the tests we performed without having to look them up in the results section.

- *Highway tunnel measurements: You already state in the text that the CO<sub>2</sub> concentration increases throughout the tunnel due to accumulation, but the canister for COS is mainly filled at the beginning. Assuming COS and CO<sub>2</sub> concentrations are correlated in the tunnel (which is safe to assume if both have traffic emissions as their main source), what does that mean for the COS:CO<sub>2</sub> ratio that you give? Is the resulting ratio rather a lower limit for the COS:CO<sub>2</sub> ratio?*

The reported COS:CO<sub>2</sub> ratios are enhancements above the background mixing ratios of COS and CO<sub>2</sub>. Thus, the fact that most sampling took place closer to the entrance of the tunnel will not affect the ratios as we compensate for the amount of background COS and CO<sub>2</sub> that are also present in the samples. The second paragraph of the highway tunnel measurements results section states: "From these values we calculated the COS/CO<sub>2</sub> **enhancement** ratio..."

### Results

- *Fig. 3: the curve for d33S seems to strongly depend on the point at 0.4 Vs. Any idea on what causes this outlier, which is also a "low outlier" for d34S? Can you say sth on how consistent this pattern with this one outlier at 0.4 Vs is? How different is the fitted curve if the one at 0.4 Vs is omitted?*

The precision of the mass spectrometer can change slightly sometimes due to several reasons (change of filament, focus settings among others). We performed a test at 0.4 Vs and at that moment the precision was very good. It is unclear as to why exactly the precision was that good at that moment. If we omit this outlier, we get this figure linked here: [https://s3-eu-west-1.amazonaws.com/openreseurope/linked/194968.figure3\\_no\\_0.4Vs.pdf](https://s3-eu-west-1.amazonaws.com/openreseurope/linked/194968.figure3_no_0.4Vs.pdf)

We can see that the regression line indeed changes quite a bit towards the lower peak areas, but hardly at the higher peak areas of >0.5 Vs. As all the results presented in this paper have a peak area of >0.5 Vs, and most even >0.6 Vs, changing this regression line for calculating the errors will not make a significant difference for the measurement errors. However, for future measurements, we will do more measurements to characterize the reproducibility (system precision).

- *Fig 3 caption/text: Method and caption say n=7-8, but text says n=6-8, please correct appropriately.*

It indeed should have been n=6-8. It is now changed in the methods section and in the figure 3 caption.

- *To show the reproducibility (precision), I would have expected to see a figure with all individual data points. In the method section you state that reproducibility is tested by having 1L, 2L and 3L in 7-8 repetitions for two gases. I would suggest showing this in detail.*

I think a figure with all the measurements will be a bit less informative than figure 3. Since we used different gases to determine the precision and we also calculate the precision using this student t-distribution. If you show all the measurements in one plot this will be a big cloud of points with different colors (for the different gases) and it will not become

immediately apparent what the precision is, depending on the peak area (sample volume).

- *Nonlinearity: You state that the nonlinearity is small and that only a small correction was needed. I may be missing sth here, but which correction did you actually apply? Can you give the exact equation?*

The equations are now included in the section (equation 6 and 7). I also noticed that the equation numbering in version 1 of the paper was incorrect. This has been solved now.

- *Can you describe why the scatter is so different for d34S and d33S in Fig. 4 and especially Fig. 5?*

Our measurement precision (reproducibility) is lower for d33S than for d34S. This is due to the lower natural abundance of  $^{33}\text{S}$  (0.75%) compared to  $^{34}\text{S}$  (4.25%). From this, one would expect to have approximately a 2 times higher reproducibility for d34S than for d33S. We have slightly lower precision for d33S than d34S (2.1‰ for d33S and 0.4‰ for d34S). That is why we see so much more scatter for d33S compared to d34S in the data.

- *Fig 6: It is good to be transparent about the second canister as a replacement after the first one was exhausted, and you state that clearly in the methods. For increasing the visibility of the plot, I suggest writing in the caption that both target gases are designed to be comparable, i.e. should have the same concentration. At least to me, this was confusing at the first look because they have different colors, so I had to go back to the method section to check what the difference between the two gases is.*

Good point. An extra explanation is added to the caption of figure 6. However, they were not really designed to have the same concentration. As can be seen in figure 6, the second target gas does have higher mixing ratio than the first one. They were simply gases that were stable in larger cylinders so that they would not be exhausted that quickly.

- *Measurements in Utrecht: "More generally, European anthropogenic COS emissions in the Netherlands are likely small" - I think I understand what you mean, but the sentence needs revising. Maybe: "More generally, the impact of European anthropogenic COS emissions in the Netherlands are likely small". Still, how do you explain the increase in mixing ratio of COS that seemed to decrease again when CO2 and CH4 mixing ratios were still high?*

This sentence was indeed not clear. It is now changed into: "More generally, the impact of European anthropogenic emissions on the COS budget in the Netherlands is likely small, because we generally do not see events with high COS mixing ratios and/or very depleted values of  $\delta^{34}\text{S}$  during our measurement period." About the measurements in figure 8: we do indeed not completely understand why the COS mixing ratio increased during the pollution event and then decreased again while CH<sub>4</sub> and CO<sub>2</sub> kept increasing. We expected the COS to increase together with CH<sub>4</sub> and CO<sub>2</sub>. However, as these are measurements taken with approximately 2-hour increments, we can expect some variability in the air trajectories between measurements. It could be that this one high COS measurement picked up a local source of COS that the other measurements did not see. CH<sub>4</sub> and CO<sub>2</sub> sources are more widespread (such as traffic and industries). However, COS sources are likely more like individual point sources which can either be picked up by the measurement or not, if the trajectory changes slightly. Furthermore, during these measurements, we had very stable cold weather in Utrecht, which was likely trapping pollution during the night. The 8<sup>th</sup> measurement (with high COS mixing ratio) was taken around 9:30 in the morning on the 2<sup>nd</sup> of December. Afterwards, there were some reference gas measurements (hence the time gap in figure 8) and the next ambient air measurement was taken at around 13:30. In the afternoon, boundary layer mixing will have occurred, so we probably also see a reflection of these different conditions.



- *Conclusion: could you compare the errors to the errors of the previous methods? What is the final take on the trade-off between sample volume and uncertainty compared to the other methods?*

Angert *et al.* (2019) report a precision of  $\leq 0.5$  ‰ for ambient air measurements taken from samples in 2.25 L canisters with 9 repetitions. They use an ICP-MS which is a very different and much more expensive type of mass spectrometer, so our measurements are difficult to compare to theirs in terms of precision and trade-offs. Kamezaki *et al.* (2019) report a precision of 0.4 ‰ for measurements where COS is pre-concentrated from 500 L of air and then measured using GC-IRMS. Our method also uses GC-IRMS but we correct for the nonlinearity and then are able to measure with 0.9 ‰ precision for a 4 L sample, which are much easier to collect in the field or in experiments than 500 L of air. Because our method uses less air we possibly have fewer errors during the pre-concentration phase. And also because of this small sample size, we are able to use an air cylinder with ambient COS mixing ratio as a reference gas. Thus, the reference measurements and sample measurements proceed in the same way. The downside of our method is that we have to keep characterizing the nonlinearity of the measurements as this behavior could change over time. These testing measurements are somewhat time-consuming and would not be necessary this often if one would measure outside of the nonlinear regime (e.g. much larger sample volumes). We do have about double the standard deviation of the measurements by Kamezaki *et al.* (2019), however, our sample standard deviation is usually still below 1 ‰ for d34S which is good enough to see differences in ambient COS isotopic composition. Furthermore, we do not have an independent calibration method, thus the accuracy of our results depends on the accuracy of the calibration measurements in Japan and on the stability of the calibration gases provided to us. I confirm that the links for underlying and extended data are working, and the data is fully accessible. I randomly checked some of the files and realised that e.g. in `COS_isotopes_ambient_air_data_Baartman_et_al.xlsx`, the units are missing (while they are present in other files). It becomes clear from the context that it must be ppt, but would be helpful to add units for non COS-experts. Thank you for pointing this out. I actually found that more files were missing units. I included all the units now and the new files can be found in the extended data with the new DOI: <https://doi.org/10.5281/zenodo.6319758>

**Competing Interests:** No competing interests were disclosed.