

# Stochastic Resonance Exploration in Current-driven ReRAM Devices

Albert Cirera  
Dept. of Electronics and  
Biomedical Eng.  
Universitat de Barcelona  
Barcelona, Spain  
acirera@ub.edu

Ioannis Vourkas  
Dept. of Electronic  
Engineering  
Universidad Tecnica  
Federico Santa Maria  
Valparaiso, Chile  
ioannis.vourkas@usm.cl

Antonio Rubio  
Dept. of Electronic  
Engineering  
Universitat Politècnica de  
Catalunya  
Barcelona, Spain  
antonio.rubio@upc.edu

Marcelo Perez  
Dept. of Electronic  
Engineering  
Universidad Tecnica  
Federico Santa Maria  
Valparaiso, Chile  
marcelo.perez@usm.cl

**Abstract**— Advances in emerging resistive random-access memory (ReRAM) technology show promise for its use in future computing systems, enabling neuromorphic and memory-centric computing architectures. However, one aspect that holds back the widespread practical use of ReRAM is the behavioral variability of resistive switching devices. In this context, a radically new path towards ReRAM-based electronics concerns the exploitation of noise and the Stochastic Resonance (SR) phenomenon as a mechanism to mitigate the impact of variability. While SR has been already demonstrated in ReRAM devices and its potential impact has been analyzed for memory applications, related works have only focused on voltage input signals. In this work we present preliminary results concerning the exploration of SR in current-driven ReRAM devices, commercially available by *Known Inc.* Our results indicate that additive noise of amplitude  $\sigma = 0.125\mu\text{A}$  can stabilize the cycling performance of the devices, whereas higher noise amplitude improves the HRS-LRS resistance window, thus could affect positively the Bit Error Rate (BER) metric in ReRAM memory applications.

**Keywords**— *memristor; stochastic resonance, resistive switching; ReRAM; Known; voltage-controlled current source*

## I. INTRODUCTION

The resistive switching phenomenon in electronic devices has attracted a wide interest from academia and industry due to its potential to store information in form of resistance in resistive random-access memories (ReRAM) [1]. Such technology is being currently considered to enable in-memory and neuromorphic computing systems [2], [3]. The resistive switching devices, also usually called ReRAM devices or memristors [4], basically consist of an insulating layer sandwiched between two metal electrodes [5]. ReRAM devices exhibit memory when operating as two-terminal variable resistors usually due to the formation of a conductive filament (CF) between the top and bottom electrodes, as in the case of conductively bridged (CBRAM) devices. This way, the data stored in ReRAM memory cells are represented by their resistance; logic ‘0’ by a high resistive state (HRS) and logic ‘1’ by a low resistive state (LRS), or vice versa. In bipolar memristors, one voltage polarity is required to switch

the device from HRS to LRS (SET process), and the opposite polarity is required to get the cell from LRS to HRS (RESET process), provided that the applied voltage exceeds certain thresholds. The SET operation is achieved when CF is formed whereas the RESET is achieved when CF is dissolved [6], [7].

One of the main current issues with ReRAM technology is the behavioral variability [8]. Temporal (cycle-to-cycle) variations are attributed to the stochastic nature of resistive switching, which is very hard to tackle at the material level. It heavily affects the ReRAM reliability and consequently the commercialization possibilities of ReRAM-based products due to the reduced robustness of such systems. For instance, temporal variability strongly affects the Bit Error Rate (BER) metric in ReRAM modules, calculated as the percentage of failed writing processes out of the total amount of writing events to the memory cells. In this context, a radically new path towards practical ReRAM-based applications concerns the exploitation of noise and particularly the Stochastic Resonance (SR) phenomenon [9], as a mechanism to mitigate the impact of variability through improved write and read processes.

The constructive role of noise in physical systems was made famous in the 1980s with SR [10]. SR can occur in nonlinear systems subjected to an input signal when their response becomes maximal for a specific level of noise, provided that, in the absence of noise, their response to the same signal is suboptimal and that any further increase in noise intensity produces a loss of coherence in the system’s response [11]. Changing the state of memristors using white noise was first discussed in [12]. However, more recent works have identified SR experimentally [13], [14], when the temporal stability of the switching performance and the achieved HRS-to-LRS resistance window of devices were improved using superimposed noise with the applied voltage signal, which was insufficient to cause the complete SET and RESET switching in the absence of external noise. This effect was mostly pronounced only for a certain level of noise intensity, thus validating the occurrence of SR. So far, most of the work related to ReRAM and SR considers biasing the devices using voltage. However, to the best of our knowledge, no previous SR observations have been reported when the ReRAM is driven directly with current. Therefore, in this work we present some preliminary results concerning demonstration of SR in current-driven ReRAM devices.

---

Supported by the Chilean research grants FONDECYT INICIACION 11180706 and ANID-Basal FB0008, and by the Spanish MCIN grants PID2019-105658RB-I00, and MCIN/AEI/10.13039/501100011033 grant PID2019-103869RB-C33.

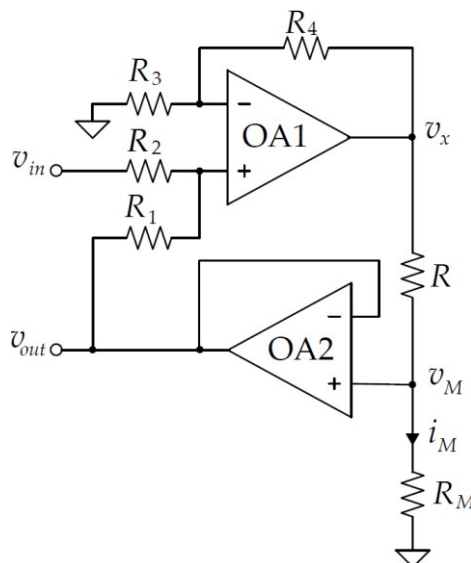

Fig. 1 Schematic of the custom circuit used in the measurement setup as a current controller.  $R_M$  represents the ReRAM device under test.

Particularly, a set of commercially available memristors by *Knowm Inc* [15] were tested and controlled with a nano-ampere level current source [16]. Current-based programming of memristors can be advantageous compared to voltage-based approaches, simplifying (practically eliminating) the forming process and directly protecting the device under test. Moreover, our measurements indicate that an additive noise to the applied current signal can improve the cycle-to-cycle variability of the devices and the HRS-to-LRS resistance window, thus impacting positively the potential Bit Error Rate (BER) metric in ReRAM modules, as also commented in [13].

## II. EXPERIMENTAL SETUP

In this work we use the commercial self-directed-channel (SDC) bipolar RS devices by *Knowm Inc.* [15], [17]. SDC devices constitute an ion-conducting device type, a sub-class of electrochemical metallization (ECM) devices which, in response to an applied voltage, uses a metal-catalyzed reaction within the device active layer to generate conductive channels (Ag ion transport routes) that contain Ag agglomeration sites, permanent under similar operating conditions.

Measurements and signal generation, including noise injection, were carried out using the digital oscilloscope and function generator of the Digilent ADP3450 instrumentation tool, whereas the current-driven characterization was performed using a custom circuit of a voltage controlled low-current source, shown in Fig. 1. Such circuit was previously reported in different application fields where stable currents in the pico-/nano-ampere range were required [16], [18]. It is composed by two operational amplifiers (OA1 and OA2), four configuration resistors  $R_1 - R_4$ , and one measuring resistor  $R$ , whereas the memristor is represented by  $R_M$ . The OA1 is in non-inverter summation configuration, whereas the OA2 is in voltage follower configuration, such that  $V_M = V_{OUT}$ , allowing to continuously monitor the voltage drop on the device. To obtain a stable current  $I_M$  independent of the resistance of the ReRAM device  $R_M$ , it can be shown that the following equation must hold:  $R_1R_3 - R_2R_4 = 0$ . Thus, in our setup the values of the configuration resistors were selected as  $R_2 = R_3$

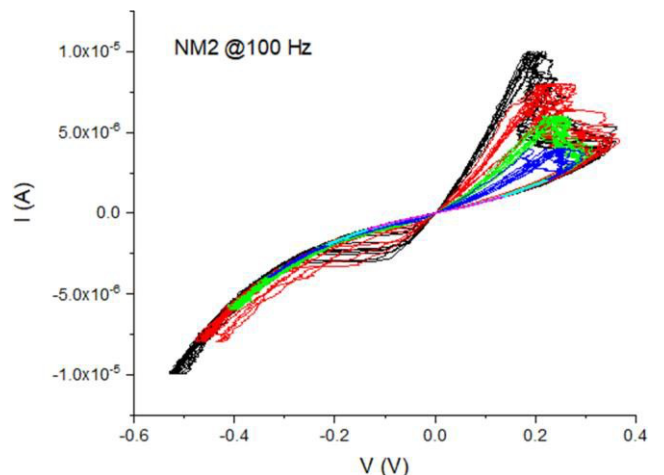

Fig. 2 Current-voltage characteristic of current driven operation of a ReRAM device (NM2) subjected to 10 cycles of a 100-Hz triangular current wave of different amplitudes between 1uA and 10uA.

$= 33k\Omega$  and  $R_1 = R_4 = 10k\Omega$ . We used the ADTL082 operational amplifier due to its high speed, high slew rate, and low input bias current and voltage, with  $\pm 12V$  supply voltage. This way, the current through the ReRAM device  $I_M$  depends only on the applied control voltage  $V_{IN}$ , the ratio  $R_2/R_1$  and  $R$ , as shown in (1):

$$I_M = V_{IN} / [(R_2 / R_1) \cdot R] \quad (\square)$$

## III. RESULTS & DISCUSSION

Using the described circuit setup, a set of BS-AF-W discrete SDC bipolar ReRAM devices by *Knowm Inc.* were submitted to 100-Hz symmetric triangular current waves of amplitude ranging between 1uA and 10uA. Such amplitude is much lower than the 1mA maximum current recommended for these devices by *Knowm Inc.* It is worth mentioning that in all such current-driven experiments, the forming process was not a separate required process, since the conductive channel in the devices was immediately formed at the very first cycle of operation.

In the results depicted in Fig. 2 we observe the corresponding current-voltage ( $I-V$ ) curves, where higher current amplitudes drive the devices to smaller LRS values and thus to larger lobes in the hysteresis loop, similar to what has been observed in other works where voltage was used as input signal [19], [20].

We next explored the effect of introducing noise to the applied signal and the results are shown in Fig. 3a and Fig. 4a. The device under test was submitted to 10-Hz symmetric triangular current waves of 5uA amplitude. A 1-kHz noisy signal of amplitude ranging between 0.1uA and 1uA was superimposed to the baseline driving current wave. Although the amplitude of the baseline signal without noise is already sufficient to produce a hysteresis loop, the main idea of noise injection is to explore if the switching behavior of the devices can be improved over the corresponding no-noise case. It can be observed that a noise with moderate amplitude of  $\sigma=0.125uA$  tends to qualitatively stabilize the cycling performance of the device and yields uniform voltage dynamics, as observed in Fig. 3b. Increasing the noise amplitude leads to a gradual loss of the hysteresis loop, as can

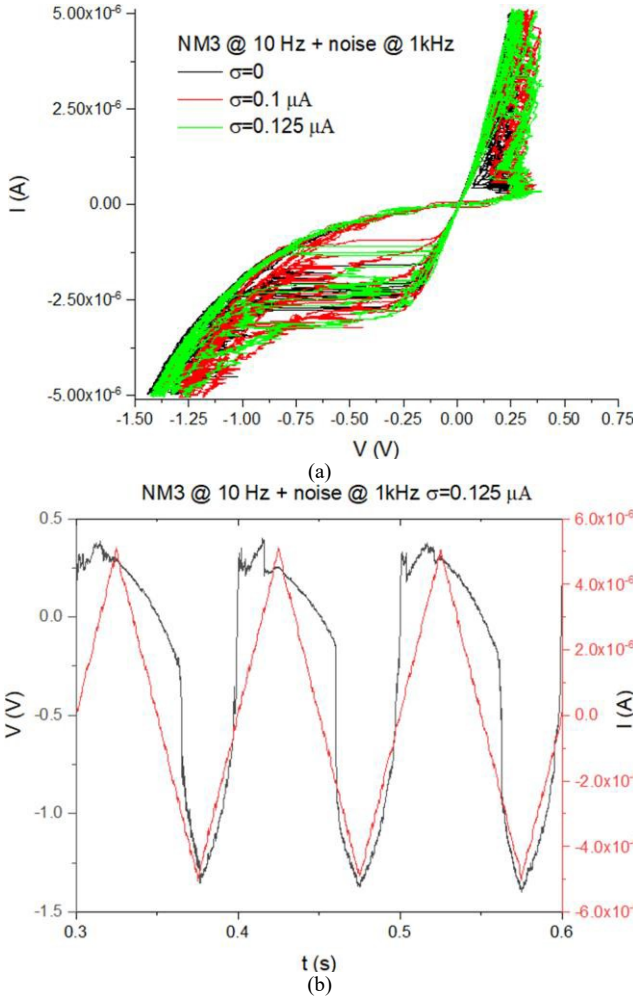

Fig. 3 (a)  $I$ - $V$  characteristic of a current-driven ReRAM device (NM3) subjected to a 10-Hz triangular current wave of 5-uA amplitude with superimposed noise of amplitude  $\sigma=0$ , 0.1  $\mu\text{A}$  and 0.125  $\mu\text{A}$ . (b) Time evolution of the voltage on the ReRAM device during a selected time frame of the applied triangular current wave with a superimposed 1-kHz noise of 0.125- $\mu\text{A}$  amplitude.

be seen in Fig. 4a, even though the observation of the time-evolution of the voltage drop on the device in Fig. 4b reveals that the main features of SET and RESET are largely conserved, even for high-noise amplitudes that reach to 1  $\mu\text{A}$  that completely distort the baseline signal.

Thus, so far, we can figure out that certain intensities of the introduced noise are able to improve the quality of memristor's cycling performance, observed through the quality of the hysteresis loop in the  $I$ - $V$  curves.

Next, we focused on the time evolution of the HRS and LRS resistance values of the device which was subjected to 10 sequences of SET and RESET write operations with intermediate reading of its state. The applied write pulses were 10-ms wide and had an amplitude of  $\pm 5 \mu\text{A}$ , whereas the read operations were performed at 0.85  $\mu\text{A}$  (two consecutive read pulses were applied to check state retention). Inspired by [13], our objective here was to evaluate the potential improvement in write operations by the injection of 100-kHz noise of different amplitudes, which could alleviate the BER problem in ReRAM memory modules.

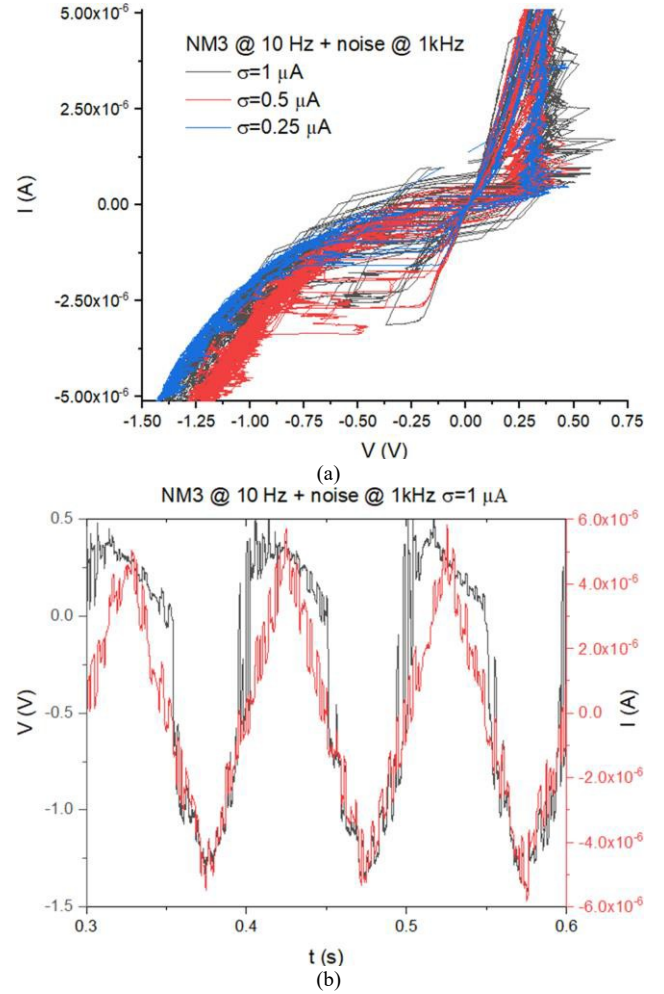

Fig. 4 (a)  $I$ - $V$  characteristic of a current-driven ReRAM device (NM3) subjected to a 10-Hz triangular current wave of 5-uA amplitude with superimposed noise of amplitude  $\sigma=0.25 \mu\text{A}$ , 0.5  $\mu\text{A}$  and 1.0  $\mu\text{A}$ . (b) Time evolution of the voltage on the ReRAM device during a selected time frame of the applied triangular current wave with a superimposed 1-kHz noise of 1.0- $\mu\text{A}$  amplitude.

By observing the results shown in Fig. 5a we can figure out that, while using symmetric SET/RESET current pulses without noise, the obtained HRS and LRS values could lead to a high BER since they frequently overlap or are close to the central part of the HRS-to-LRS resistance range, where values usually correspond to unidentified stored state. However, the introduction of additive noise to the applied current pulses leads to improved write operations. More specifically, a  $\sigma = 0.125 \mu\text{A}$  noise amplitude improves the uniformity of HRS values, as shown in Fig. 5b, whereas a higher amplitude of  $\sigma = 0.5 \mu\text{A}$  qualitatively improves also the LRS uniformity, as seen in Fig. 5c. Therefore, although a more exhaustive exploration of noise intensities and the use of asymmetric SET/RESET write amplitudes is required for clearer conclusions about the benefits of noise and the occurrence of SR, such preliminary results confirm that additive noise of up to 10% of the baseline pulse amplitude could substantially improve the stability of resistive switching performance, thus paving the way towards new approaches based on the use of noise to better control the dynamic response of ReRAM devices during SET and RESET.

#### IV. CONCLUSIONS

Following previous research works that claimed noise and stochastic resonance (SR) can be promising for ReRAM applications, here we explored the occurrence of SR in current-driven devices using a voltage-controlled current source. Even though finding the optimal noise intensity that has a positive impact to the device operation is challenging, our preliminary results confirm that additive noise can substantially improve the stability of resistive switching performance when current read/write pulses are used rather than voltage. Current-driven ReRAM devices exhibited an improved hysteresis performance when noise was increased to a certain level, whereas for higher values the hysteresis was lost. Such behavior can be identified as SR.

#### REFERENCES

- [1] G T.-C. Chang, K.-C. Chang, T.-M. Tsai, T.-J. Chu, and S. M. Sze, "Resistance random access memory," *Mater. Today*, vol. 19, no. 5, pp. 254–264, Jun. 2016
- [2] M. A. Nugent, T. W. Molter, "Thermodynamic-RAM technology stack," *Int. Journal of Parallel, Emergent and Distributed Systems*, vol. 33, no. 4, pp. 430–444, 2018
- [3] M. A. Zidan, J. P. Strachan, and W. D. Lu, "The future of electronics based on memristive systems," *Nat Electron.*, vol. 1, pp. 22–29, 2018
- [4] D. B. Strukov, G. S. Snider, D. R. Stewart, and R. S. Williams, "The missing memristor found," *Nature*, vol. 453, pp. 80–83, 2008
- [5] A. G. Vescio, *et al.*, "Inkjet Printed HfO<sub>2</sub>-Based ReRAMs: First Demonstration and Performance Characterization" *IEEE Electron Device Letters*, vol. 38, no. 4, pp. 457–460, 2017
- [6] G. Sassine, *et al.*, "Interfacial versus filamentary resistive switching in TiO<sub>2</sub> and HfO<sub>2</sub> devices" *Jour. of Vacuum Science & Technology*, vol. B34, no. 012202, 2016
- [7] H. García, S. Dueñas, O.G. Ossorio, H. Castán, "Current Pulses to Control the Conductance in RRAM Devices", *J. Electron Dev. Soc.* vol 8, pp. 291-296, 2020
- [8] P. Pouyan, E. Amat, S. Hamdioui, and A. Rubio, "Resistive Random Access Memory Variability and Its Mitigation Schemes," *Journal of Low Power Electronics*, vol. 13, no. 1, pp. 124–134, 2017
- [9] L. Gammaitoni, P. Hanggi, P. Jung, and F. Marchesoni, "Stochastic Resonance," *Reviews of modern physics*, vol. 70, no. 1, p. 223, 1998
- [10] B. McNamara and K. Wiesenfeld, "Theory of stochastic resonance," *Physical Review A*, vol. 39, no. 9, p. 4854, 1989
- [11] A. Mizrahi, R. Laurent, J. Grollier, D. Querlioz, "Exploiting the stochasticity of memristive devices for computing," in "Memristive Devices for Brain-Inspired Computing", *Woodhead Publishing Series in Electronic and Optical Materials*, pp. 275–309, 2020
- [12] V. Slipko, Y. Pershin, and M. Di Ventra, "Changing the state of a memristive system with white noise," *Phys. Rev. E*, vol 87 (042103), 2013
- [13] V. Ntinias, *et al.*, "Power-efficient Noise-Induced Reduction of ReRAM Cell's Temporal Variability Effects", *IEEE Trans. on Circuits and Systems II: Express Briefs*, vol 68, pp. 1378–1382, 2021
- [14] A. N. Mikhaylov, *et al.*, "Stochastic resonance in a metal-oxide memristive device," *Chaos, Solitons & Fractals*, vol. 144 (110723), 2021
- [15] Knowm Inc., [Online]. Available: <https://knowm.org>
- [16] E. Pescio, Ridi A and Gliozzi A "A picoampere current generator for membrane electroporation" *Rev. Sci. Instrum.*, vol.71, pp. 1740, 2000
- [17] K. Campbell, "The Self-directed Channel Memristor: Operational Dependence on the Metal-Chalcogenide Layer," In: L. Chua, G. Sirakoulis, A. Adamatzky (Eds) *Handbook of Memristor Networks*. Springer, Cham, pp. 815–842, 2019
- [18] J D Prades, *et al.*, "The effects of electron-hole separation on the photoconductivity of individual metal oxide nanowires" *Nanotechnology*, vol 19, pp. 465501, 2008

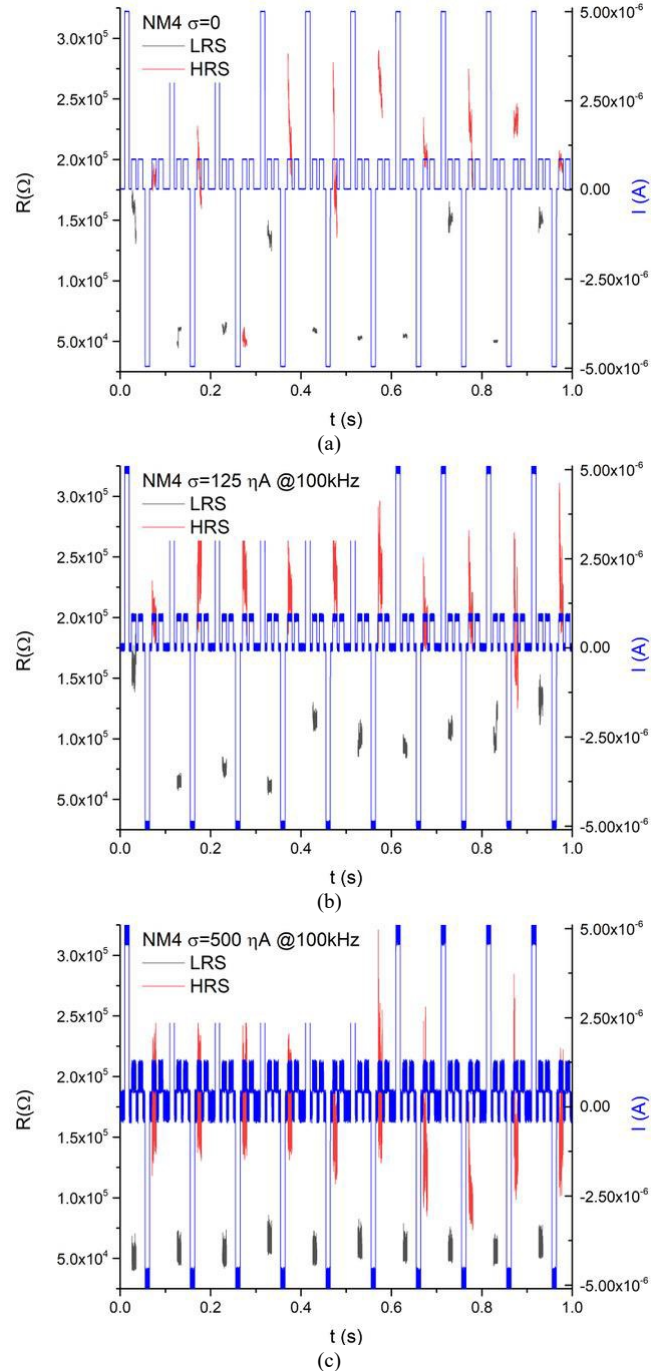

Fig. 5 Time-evolution of HRS and LRS values of a device (NM4) subjected to 10 sequences of SET and RESET write operations with 10-ms wide,  $\pm 5\mu\text{A}$  current pulses and read operations at  $0.85\mu\text{A}$ . (a) Results without noise. (b, c) Results using 100-kHz additive noise of different amplitudes.

- [19] J. Gomez, I. Vourkas, and A. Abusleme, "Exploring Memristor Multi-Level Tuning Dependencies on the Applied Pulse Properties via a Low-Cost Instrumentation Setup", *IEEE Access*, vol. 7, no. 1, pp. 59413 – 59421, 2019
- [20] V. Ostrovskii, *et al.*, "Structural and Parametric Identification of Knowm Memristors" *Nanomaterials*, vol 12, pp 63, 2022