



Aalborg Universitet

AALBORG UNIVERSITY
DENMARK

Application-Oriented Reliability Testing of Power Electronic Components and Converters

Wang, Huai; Iannuzzo, Francesco; Bahman, Amir Sajjad; Zhang, Kaichen; Xue, Peng; Zhang, Yi; Yao, Bo; Shen, Zhan; Sangwongwanich, Ariya; Vernica, Ionut; Song, Yubo; Sahoo, Subham; Blaabjerg, Frede

Published in:
IEEE Power Electronics Magazine

DOI (link to publication from Publisher):
[10.1109/mpel.2022.3218244](https://doi.org/10.1109/mpel.2022.3218244)

Publication date:
2022

Document Version
Accepted author manuscript, peer reviewed version

[Link to publication from Aalborg University](#)

Citation for published version (APA):
Wang, H., Iannuzzo, F., Bahman, A. S., Zhang, K., Xue, P., Zhang, Y., Yao, B., Shen, Z., Sangwongwanich, A., Vernica, I., Song, Y., Sahoo, S., & Blaabjerg, F. (2022). Application-Oriented Reliability Testing of Power Electronic Components and Converters. *IEEE Power Electronics Magazine* .
<https://doi.org/10.1109/mpel.2022.3218244>

General rights

Copyright and moral rights for the publications made accessible in the public portal are retained by the authors and/or other copyright owners and it is a condition of accessing publications that users recognise and abide by the legal requirements associated with these rights.

- Users may download and print one copy of any publication from the public portal for the purpose of private study or research.
- You may not further distribute the material or use it for any profit-making activity or commercial gain
- You may freely distribute the URL identifying the publication in the public portal -

Application-oriented Reliability Testing of Power Electronic Components and Converters

Huai Wang, Francesco Iannuzzo, Amir Sajjad Bahman, Kaichen Zhang, Peng Xue, Yi Zhang, Bo Yao, Zhan Shen, Ariya Sangwongwanich, Ionut Vernica, Yubo Song, Subham Sahoo, Frede Blaabjerg

Power electronics have been and will continue to be an enabling technology for energy production, storage, transmission, distribution, and consumption. Power electronic converters are usually the critical links in electrical energy systems, affecting system security, safety, energy efficiency, and cost-of-ownership. As a result, the reliability requirements for power electronic components and converter systems generally become more stringent, for example, in e-mobility, renewable energy generation, and power system applications. Testing is one of the vital reliability engineering tools to investigate failure mechanisms, identify weakest points, and demonstrate robustness margins. It contributes to reliability growth along the product development process and the likelihood of failure reduction in field operation. The required resources (i.e., testing time, sample size, testing facility) and the relevance of the testing results to field operation are two crucial considerations in implementing a reliability test. This article introduces the emerging application-oriented testing concepts and facilities through several component-level and converter-level examples.

Introduction to Reliability Testing

Reliability testing can be classified from different perspectives. According to testing results, there are quantitative testing methods, such as Accelerated Life Testing (ALT) [1] - [2], and qualitative testing methods, such as Highly Accelerated Life Test (HALT) [3]. For example, ALT aims to obtain quantitative results, such as time-to-failure data, degradation curves, and demonstrated reliability. On the other hand, HALT aims to find destructive limits and identify the weakest points in design or process by testing the samples close to their stress limits. According to testing purposes, test-to-failure, success-run, and Reliability Stress Screening (RSS) [4] are the three main types. Test-to-failure is to test until at least part of the samples fail to identify failure modes or obtain time-to-failure data. Success-run demonstrates the one-life of products, usually by an ALT for a given time with zero failure found. Finally, RSS aims to screen for early failure due to manufacturing processes or outliers of products before they are shipped out.

Three generations of testing concepts have evolved regarding how to implement a reliability test (e.g., testing purpose, testing samples, stress conditions, and sample size). These concepts have been illustrated in [5] by the examples of microelectronics qualification in automotive applications: stress-test-driven, knowledge-driven, and application-driven. Stress-test-driven methods have predefined test conditions and sample sizes, usually according to specific standards. Since the 2000s, knowledge-driven concepts have emerged, considering the physics of failure, and relevance to the component operation profiles. Finally, in the last decade, application-driven testing concepts have been of interest to test components and systems considering the application-level operation profiles and physics-of-degradation. The latest testing concepts increase the relevance between reliability testing and field operation, tailoring for specific applications; nevertheless, the demand for testing facilities is usually increased.

Since 2019, Aalborg University in Denmark has developed an additional series of power electronics reliability test facilities through a national infrastructure project called X-Power [6], together with other Danish universities and industry partners. Fig. 1 gives an overview of the

testing facilities covering from special testing sample preparation, component-level and system-level reliability test implementation, to post-test characterization and failure analysis. Part of the testing facilities are standard commercial equipment purchased from the market, which can perform standard tests, characterizations, and failure analyses. More information about these testing facilities can refer to [6]. The rest are customized ones developed by the team of authors of this article, which aim for application-oriented testing of power electronic components and converters. Therefore, this article focuses on application-oriented testing concepts through three component-level and three converter-level customized testing facilities.

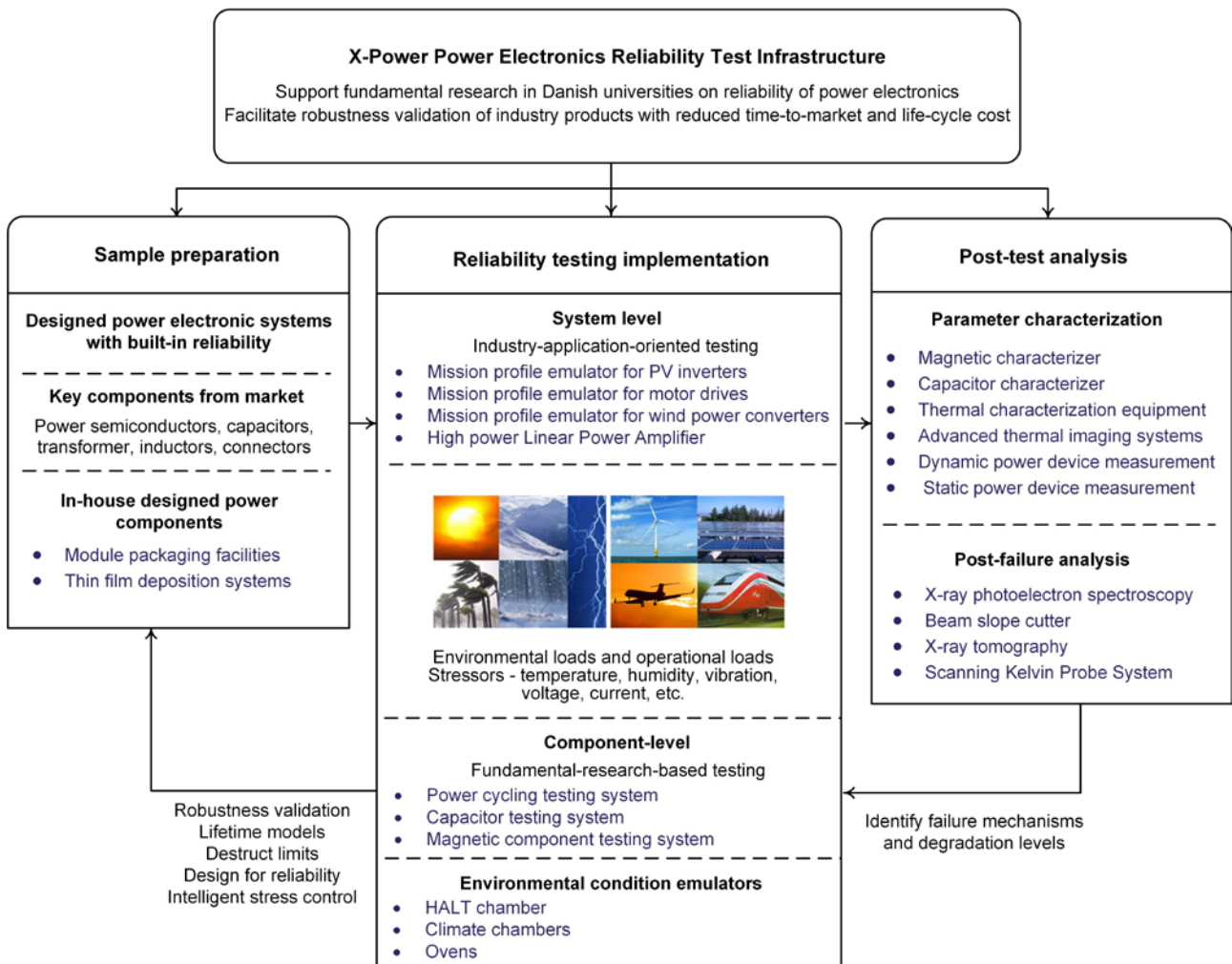

Fig. 1. Overview of the X-Power power electronics reliability test facilities at Aalborg University [1].

Component-level Application-oriented Reliability Testing

Application-oriented testing of power semiconductors

Estimating the expected life of power semiconductor switches has become an essential part of the design process, generally done by extensive accelerated power-cycling tests. So far, many different power-cycling methods have been proposed [7]. On the one hand, DC power cycling is the industry practice in standard power cycling. On the other hand, AC power cycling has become very popular in recent years because of its more realistic testing conditions for field operations. However, AC power cycling is challenging as the wear process depends on many more

parameters than DC power cycling, making AC testing platforms very complicated. Moreover, there is a significant lack of standards regarding AC power cycling, which does not help designers to identify the best implementation.

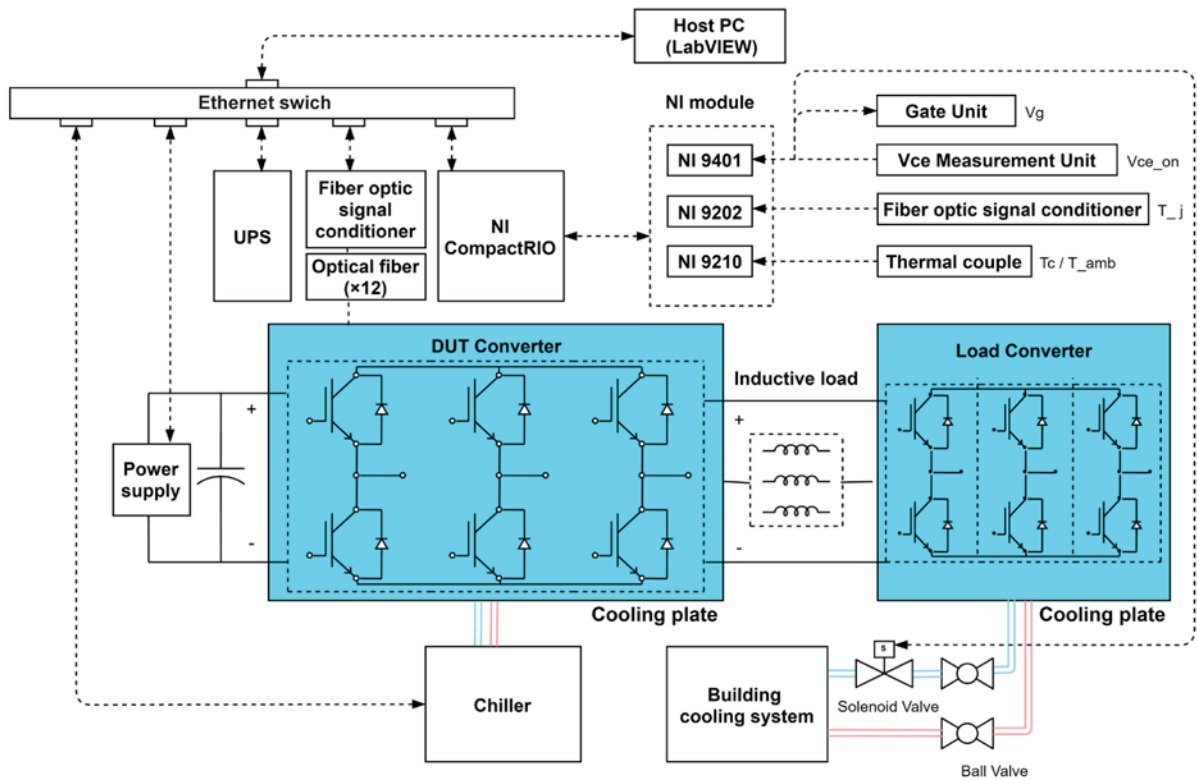

(a) Configuration of the testing system.



(b) Left: 6-unit, 19" industrial rack array; right: detailed configuration of one rack.
Fig. 2. DC- and AC Power cycling test setup.

A state-of-the-art, intelligent power cycling platform has been designed and built to meet the testing requirements. Fig. 2 shows the testing system diagrams and the photos. The system can perform the DC- and AC- power-cycling tests of power electronic discrete components and modules up to 70 Arms / 700 Vdc. Vital parameters of the Device Under Test (DUT), such as junction temperature and on-state voltage, are measured online. All the parameters and the testing strategy can be fully customized via a National Instruments CompactRIO with a LabVIEW program, which is also in charge of data logging and real-time communication with users. A 19" - standard industrial rack is used, which enables a flexible and compact test platform design. In addition, various safety precautions have been implemented to ensure a safe and stable operation.

kV/kA capacitor testing system

As discussed in [8], there are two emerging demands for capacitor testing in power electronics applications. The first is parameter characterizations under realistic operating points beyond what is provided in supplier datasheets. The testing results could help build better capacitor parametric models to optimize design margins in power converters. The second is application-oriented accelerated degradation testing under realistic voltage and current stresses. For high-power or high ripple-current applications, such as wind turbine converters, medium-voltage drives, traction inverters, and Modular Multi-level Converters, the commercial ripple current tester specifications [9] are far lower than the demands. Methods have been proposed to test electrolytic capacitors in more realistic conditions [10]-[11]. Nevertheless, extending their testing specifications is challenging due to the required power supply voltage and current ratings and the incapability of dealing with capacitor mismatch among different samples. Therefore, a new testing circuit is proposed and implemented with the details discussed in [8].

Fig. 3(a) illustrates the circuit architecture of the proposed capacitor testing system. Fig. 3(b) shows a photo of an implemented testing system. It mainly consists of a 10 kV power supply U_H , a 1 kV power supply U_L , a three-phase inverter power stack with 1.7 kV IGBT modules, and three-phase inductors. The power stack controls the currents or voltages of the three phases individually or as that of a normal inverter. The low-voltage power supply only needs to provide the entire testing system's power losses. The inductors are used to further boost the AC voltage capability without increasing the required voltage levels of U_L and the power stack components. The 10 kV power supply provides the DC bias voltage for DC capacitor testing with negligible current requirement. The testing system can test capacitors with up to 10 kV DC voltage, 1.2 kA AC ripple current, and 1.8 kV AC voltage ripple. Meanwhile, the capacitor samples can be put in climate chambers to experience temperature and humidity. The system is equipped with thermal and electrical signal monitoring systems. Key capacitor parameters can be measured online, such as voltage, ripple current, capacitance, case temperature, and hotspot temperature (for special samples with integrated thermal sensors).

By configuring the internal structure and the power stack control, the capacitor testing system can emulate different electrical stresses with the following advantages:

- Different ripple current/voltage and DC voltage can be emulated by configuring the test bench, and the DC and AC capacitors can be concurrently tested.
- Critical electrical stresses can be continuously applied precisely by using the proposed control during the entire life-cycle test, regardless of the Capacitor Under Tests (CUTs) degradation, making it robust to CUT degradation.
- It has the minimum requirements on the power supplies compared to [10]-[11]. As the example shown in Fig. 3(b), the currents supplied by U_H and U_L are only 34mA and 1.33 A, respectively.
- It has the highest testing capacity in terms of voltage and current ranges compared to publicly reported literature so far, to the authors' best knowledge.

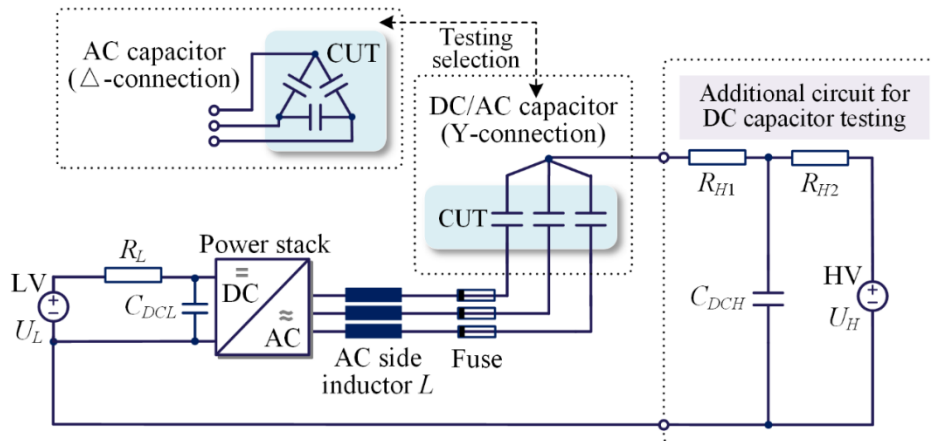

(a) Circuit architecture of the proposed capacitor testing method (for AC capacitor testing, HV source U_H , filter capacitor C_{DCH} , resistors R_{H1} , and R_{H2} can be excluded).



(b) Photo of the developed capacitor testing system.

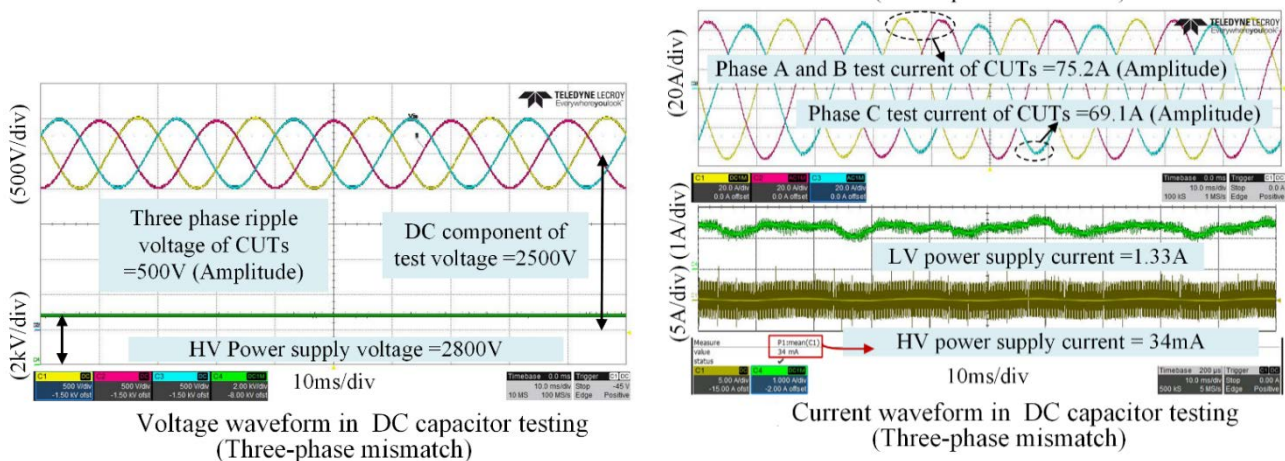

(c) An example of voltage and current waveforms in a DC capacitor test.

Fig. 3 The developed DC and AC capacitor testing system with up to 10 kV (DC), 1.8 kV (AC), and 1.2 kA (AC) [8].

20 kV/200 kHz magnetic component testing system

With the increasing application of medium-voltage, medium-frequency power electronics, realistic performance characterization and insulation degradation testing of the magnetic components have become challenging. Existing commercialized testing systems with high voltage capability mainly focus on the 50/ 60 Hz line frequency conditions. The voltage source and the characterization instruments are designed to test the magnetics for line frequency applications. To overcome the testing capacity limitation of commercial equipment, the X-Power project developed a magnetic component testing system with up to 20 kV and 200 kHz voltage pulse. The total power capacity is 20 kVA which could be further extended by upgrading the cooling system.

Fig. 4 shows the circuit configuration of the testing system. It uses the DC source to control the transformer's peak voltage and a high-voltage power electronic converter to regulate the power flowing through the transformer. By adjusting the control strategy, the voltage and current level, shape, and ringing can be precisely controlled, which emulates the electrical stresses with realistic features. Moreover, with additional environmental chamber, it can emulate different climate conditions. Further, the measurement system can obtain the key parameters during the test, including the voltage, current, and thermal signals. In the control panel, they are further calculated as the BH curve, power loss, temperature response, etc. Overall, the system can offer the testing of medium and high-frequency transformers at the rated voltage and power level.

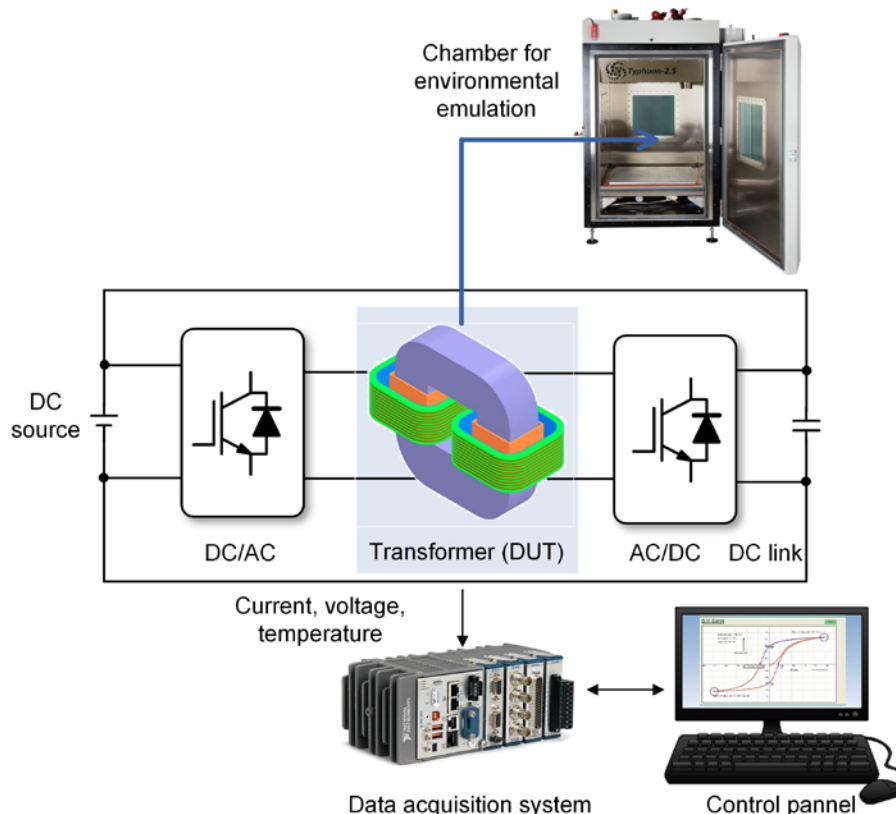

Fig. 4. Circuit architecture of the proposed 20 kV/200 kHz magnetic component testing system.

Converter-level Application-oriented Reliability Testing

Mission profile-based Photovoltaics (PV) emulator

A mission profile is a simplified representation of relevant conditions to which the items of interest

will be exposed in their intended application throughout the full life cycle of the components [12]. Various industry reliability testing standards and quality assurance protocols are reviewed in [13]. The overall goal of the PV mission profile emulator is to emulate the long-term or representative operating conditions (e.g., electrical and thermal parameters) of PV inverters at normal or accelerated conditions. In field operation, the solar irradiance and ambient temperature will determine the electrical characteristic of the PV arrays. Moreover, the ambient temperature also affects the PV inverter's power loss and thermal stress. Thus, on the input side, the mission profile emulator needs to be able to replicate the electrical characteristic of the PV arrays (e.g., power-voltage curve) under a given solar irradiance and ambient temperature conditions. Moreover, for the PV inverters with outdoor installation, the ambient temperature should also be emulated during the test. The PV inverters usually connect to the grid through the output filters on the AC side. Thus, the mission profile emulator also emulates AC grids with various normal and abnormal conditions. A measurement system is also needed to obtain parameters such as electrical and thermal characteristics during the test. For example, the input and output voltage and current are typically monitored to measure efficiency and power quality. Meanwhile, the thermal stress parameters, such as local temperatures, are usually required for reliability consideration.

Five PV mission profile emulators have been developed based on the above considerations. Fig. 5(a) illustrates the circuit architecture, and Fig. 5(b) shows the photos of the testing systems. On the DC side, the DC power supply emulates the electrical characteristic (e.g., power-voltage curve) of the PV arrays under dynamic solar irradiance and ambient temperature conditions. The PV inverter is the DUT which can be placed between the PV simulator and the AC grid. The DUT achieves maximum power point tracking during operation by controlling the power extraction from the PV simulator. The DUT is connected to AC grid through a grid simulator. A galvanic isolation is included between the PV simulator and the AC grid. The AC grid simulator can emulate different grid characteristics such as background harmonics distortion, voltage unbalance, frequency variation, and fault operation. The electrical measurement unit consists of current and voltage sensors connected at the input and output sides of the DUT for data logging and the power analyzer for efficiency and quality measurements. The thermal measurement unit consists of temperature sensors based on optic fibers and thermal couples.

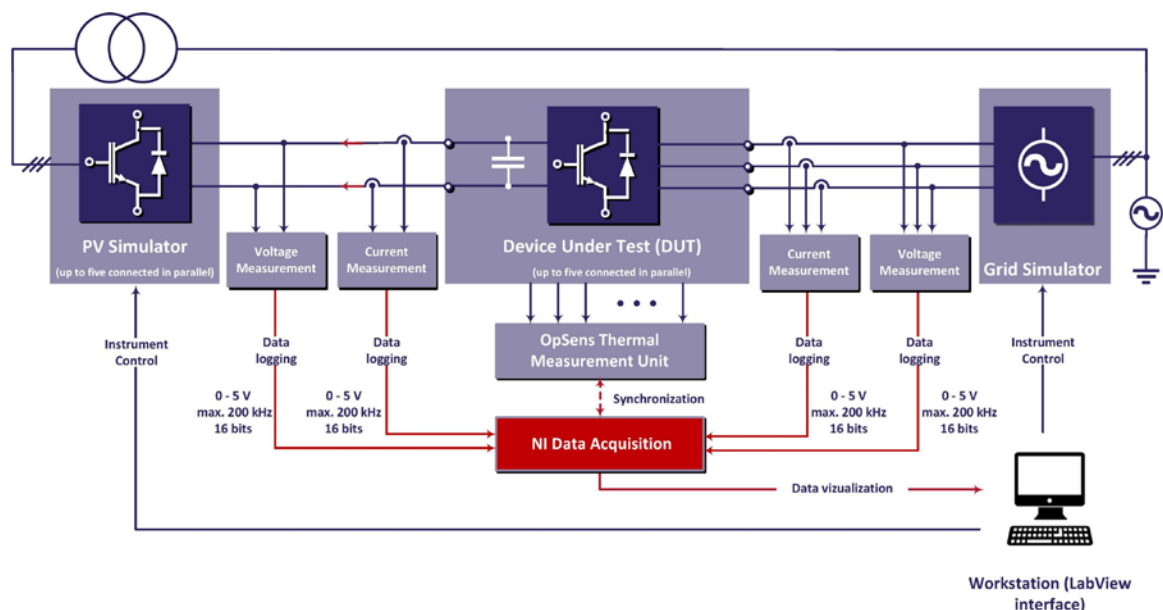

(a) Circuit architecture of the developed PV mission profile emulator.

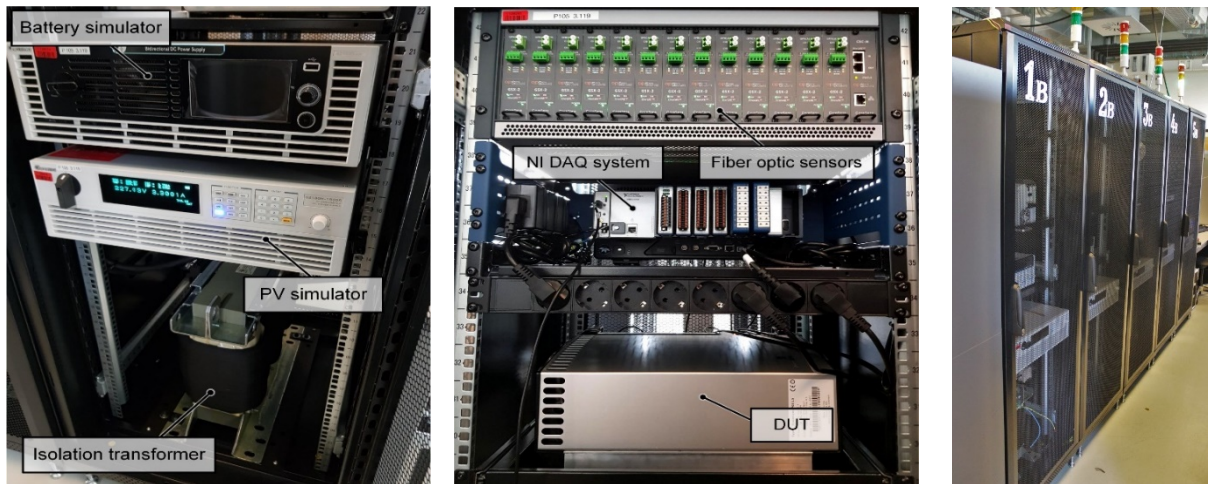

(b) Photos of the PV mission profile emulators (left and middle: different sub-systems; right: five units of the testing systems)

Fig. 5. System architecture and photos of the PV mission profile emulators.

Mission profile-based motor drive emulator

For motor drives, a mission profile typically consists of the load profiles (e.g., speed and torque) that occur on the machine side, the grid-side conditions (e.g., voltage, frequency), and environmental profiles (e.g., ambient temperature, relative humidity). These factors will influence the electrical-thermal stresses to which the drives are subject and, therefore, the reliability. Thus, a realistic emulation of the inverter mission profiles is needed to identify possible issues during the early stage of the product development cycle. A mission profile-based motor drive emulator has been developed based on the improvement of previously proposed concepts in [14]-[15]. Fig. 6 shows the system configuration and photos of the testing system. Each unit shown in Fig. 6(b) is designed for up to 50 kW under long-term testing and up to 100 kW under short-term testing. It can help investigate the impact of different critical parameters (e.g., mission profile, control algorithm, grid disturbance, etc.) on the motor drive efficiency, thermal stress, dynamic behavior, and degradation.

The DUT can be connected directly to the grid or a grid simulator at its AC side. The grid simulator can emulate various grid characteristics, such as voltage amplitude and phase imbalances, frequency variation, and fault operation. On the load side of the DUT, a four-quadrant power converter is used to emulate the machine's dynamic behavior. Using a converter-based machine emulator removes the need for installing an actual electrical machine and can conveniently perform tests with different types of motors. It is achieved through advanced emulator control strategies and detailed mathematical models that can replicate the machine's dynamic electrical behavior based on input speed/torque profiles and machine parameters.

The control of the testing system is implemented by DSP, implying a reduced cost compared to commercially available Power-Hardware-in-the-Loop testing systems. In addition, optical fiber temperature sensors and thermocouples are used for the thermal characterization of the motor drives. Finally, the data-logging of the electrical and thermal behavior of the testing platform is performed through a NI data acquisition system, which is used to record the data and aid the visualization and interaction through a user-friendly LabView interface.

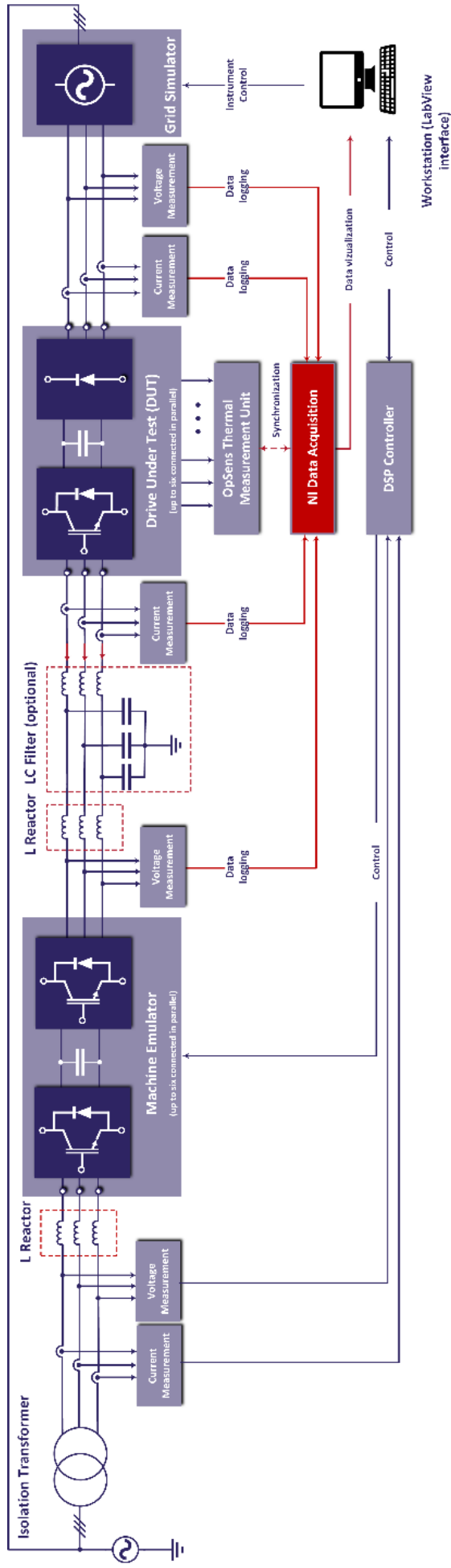

(a) Circuit architecture of the developed motor drive mission profile emulator.

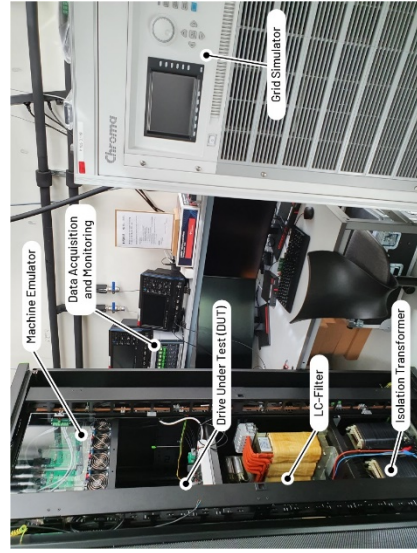

(b) Photos of the motor drive mission profile emulators (left: different sub-systems; right: six units of the testing systems)

Fig. 6 System architecture and photos of the motor drive mission profile emulators.

Power loss measurements of high-power converters through calorimetric testing

Improving the accuracy in power loss measurements can reduce uncertainty in the electro-thermal and reliability modeling, which benefits refining the design margins with a higher confidence level. Nevertheless, a confident measurement of power converter efficiency is intrinsically a critical task, as it involves the comparison of losses with delivered power, which typically differ by two orders of magnitude. The measurement methods can be classified into three main categories: direct measurement, measurement by difference, and calorimetric measurement [16] – [17].

The direct-measurement category includes all the approaches in which the losses of each component of the converter are measured directly or inferred by other measurements and added together to work out total losses. The measured-by-difference category includes only the classic approach, where losses are obtained as the input power minus the output power. This approach is simple, but it is uncertain by nature. The final uncertainty has to be divided by the difference between the two measured power values, typically around two orders of magnitude smaller than the powers themselves. This intrinsic problem can only be solved with more accurate measurements, which are very difficult to achieve beyond the second digit of precision. Finally, the calorimetric measurement category comprises all the approaches that, directly or indirectly, measure the heat produced by the converter [16]. Approaches belonging to this category do not suffer from uncertainty issues, as there is no measure by difference. However, significant difficulties arise in ensuring that all the heat is collected and correctly measured.

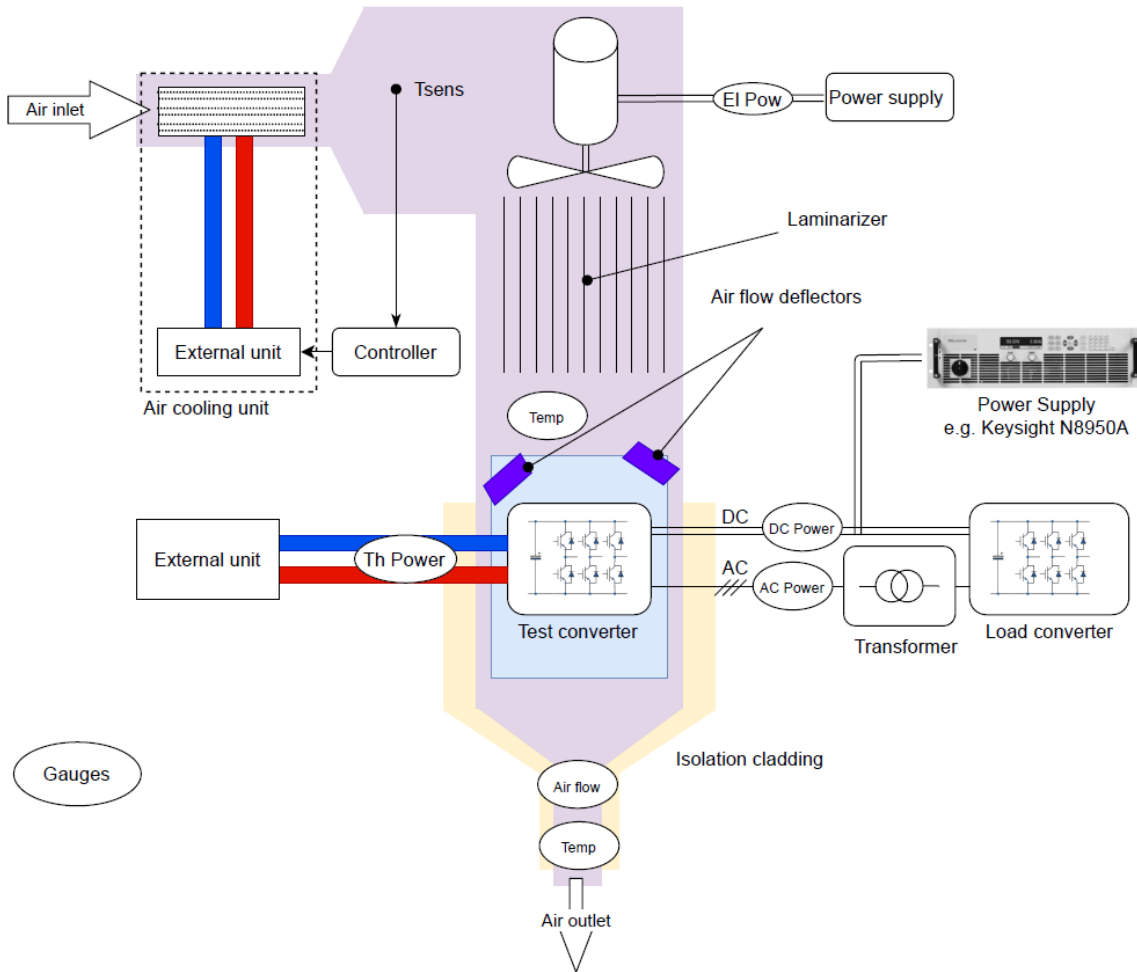

Fig. 7. System configuration of the high-power calorimetric testing system.

Fig. 7 shows the configuration of a calorimetric testing system specially developed for MW wind power converter applications. As shown in the figure, a DC power supply sets the DC-link voltage and provides the power loss of the load converter stack and testing converter stack. The system can test up to 2 MW power converters with up to 35 kW power loss in the calorimetric chamber. The measurement resolution is 55 W at 1500 m³/hr airflow.

Conclusions

Reliability testing is challenging, considering the required testing time, sample size, testing facilities, and uncertainties in failure mechanisms. This article focuses on the testing facilities which can support application-oriented characterizations and reliability tests in power electronic applications. Three component-level testing facilities are introduced for power semiconductor switches, capacitors, and magnetic components. In addition, three converter-level testing systems are presented to enable the dynamic mission profile emulation of PV inverters and motor drives and more accurate power loss measurement of MW power converters by calorimetric measurement. All six customized testing facilities are a part of the X-Power project hosted by Aalborg University. Please refer to [6] for future updates on them and other testing facilities not discussed here.

References

- [1] Wayne B. Nelson, *Accelerated Testing: Statistical Models, Test Plans, and Data Analysis*, Wiley, 2004.
- [2] IEC 62506: *Methods for product accelerated testing*, 2013.
- [3] Gregg K. Hobbs, *Accelerated Reliability Engineering: HALT and HASS*, Wiley, 2000.
- [4] IEC 611631 – 2: *Reliability stress screening – part 2: electronic components*, 2020.
- [5] René Rongen (NXP), *On the Evolution of Qualification Methods and Standards for Microelectronics in Automotive Applications beyond AEC Qxx*, presentation at PLOT conference, Nov. 2018.
- [6] X-Power project website: www.xpower.aau.dk
- [7] H. Wang and F. Blaabjerg, "Power electronics reliability: state of the art and outlook," *IEEE Journal of Emerging and Selected Topics in Power Electronics*, vol. 9, no. 6, pp. 6476 – 6493, Dec. 2021.
- [8] B. Yao, Q. Wang, H. Wang, K. Hasegawa, and H. Wang, "A robust testing method for DC and AC capacitors with minimum required power supply," *IEEE Transactions on Power Electronics*, vol. 37, no. 5, pp. 4942 – 4946, May 2022.
- [9] Chroma ATE Inc, "Ripple current tester model 11800/11801/11810.," <https://www.meatest.com/files/download/dat/2012-GC-11800-11801-11810.pdf>
- [10] K. Hasegawa, I. Omura, and S.-i. Nishizawa, "Design and analysis of a new evaluation circuit for capacitors used in a high-power three-phase inverter," *IEEE Trans. Ind. Electron.*, vol. 63, no. 5, pp. 2679–2687, May. 2016.
- [11] X. Wang, M. Karami, and R. M. Tallam, "Test fixtures to apply variable dc bias and ac ripple current for reliability testing of electrolytic capacitors," *IEEE Trans. Ind. Appl.*, vol. 55, no. 4, pp. 4073–4079, Jul./Aug. 2019.
- [12] ZVEI, *Robustness Validation Handbook of Automotive Electrical/Electronic Modules*, 2013.
- [13] P. Hacke, S. Lokanath, P. Williams, A. Vasan, P. Sochor, G. Tamizh- Mani, H. Shinohara, and S. Kurtz, "A status review of photovoltaic power conversion equipment reliability, safety, and quality assurance protocols," *Renewable Sustainable Energy Rev.*, vol. 82, pp. 1097–1112, Feb. 2018.

- [14] I. Vernica, F. Blaabjerg, and K. Ma, "Mission profile emulator for the power electronics systems of motor drive applications," in *Proc. ECCE Europe*, pp. P.1-P.10, 2017.
- [15] K. Ma and Y. Song, "Power-electronic-based electric machine emulator using direct impedance regulation," *IEEE Trans. Power Electron.*, vol. 35, no. 10, pp. 10673 – 10680, Oct. 2020.
- [16] D. Christen, U. Badstuebner, J. Biela, and J.W. Kolar, "Calorimetric power loss measurement for highly efficient converters," in *Proc. International Power Electronics Conference*, pp. 1438-1445, 2010.
- [17] M. Pagitsch, G. Jacobs, R. Schelenz, D. Bosse, C. Liewen, S. Reisch, and M. Deicke, "Feasibility of large-scale calorimetric efficiency measurement for wind turbine generator drivetrains," *Journal of Physics: Conference Series 753*, 2016.

About the authors

Huai Wang (hwa@energy.aau.dk), Professor at the Department of Energy, Aalborg University, Denmark.

Francesco Iannuzzo (fia@energy.aau.dk), Professor at the Department of Energy, Aalborg University, Denmark.

Amir Sajjad Bahman (amir@energy.aau.dk), Associate Professor at the Department of Energy, Aalborg University, Denmark.

Kaichen Zhang (kzh@energy.aau.dk), Research Assistant at the Department of Energy, Aalborg University, Denmark.

Peng Xue (pexu@energy.aau.dk), Postdoc at the Department of Energy, Aalborg University, Denmark.

Yi Zhang (yiz@energy.aau.dk), Postdoc at the Department of Energy, Aalborg University, Denmark.

Bo Yao (ybo@energy.aau.dk), PhD student at the Department of Energy, Aalborg University, Denmark.

Zhan Shen (zhs@seu.edu.cn), Associate Professor at Southeast University, China, previous PhD student and postdoc at Aalborg University, Denmark.

Ariya Sangwongwanich (ars@energy.aau.dk), Assistant Professor at the Department of Energy, Aalborg University, Denmark.

Ionut Vernica (iov@energy.aau.dk), Postdoc at the Department of Energy, Aalborg University, Denmark.

Yubo Song (yuboso@energy.aau.dk), PhD student at the Department of Energy, Aalborg University, Denmark.

Subham Sahoo (sssa@energy.aau.dk), Assistant Professor at the Department of Energy, Aalborg University, Denmark.

Frede Blaabjerg (fbl@energy.aau.dk), Professor at the Department of Energy, Aalborg University, Denmark.