

University of Groningen

A gantry for particle therapy as an arm rotating in the longitudinal plane

Schippers, Jacobus Maarten; Gerbershagen, Alexander

IMPORTANT NOTE: You are advised to consult the publisher's version (publisher's PDF) if you wish to cite from it. Please check the document version below.

Document Version

Publisher's PDF, also known as Version of record

Publication date:

2018

[Link to publication in University of Groningen/UMCG research database](#)

Citation for published version (APA):

Schippers, J. M., & Gerbershagen, A. (2018). A gantry for particle therapy as an arm rotating in the longitudinal plane. (Patent No. *WO2018028863*).

Copyright

Other than for strictly personal use, it is not permitted to download or to forward/distribute the text or part of it without the consent of the author(s) and/or copyright holder(s), unless the work is under an open content license (like Creative Commons).

The publication may also be distributed here under the terms of Article 25fa of the Dutch Copyright Act, indicated by the "Taverne" license. More information can be found on the University of Groningen website: <https://www.rug.nl/library/open-access/self-archiving-pure/taverne-amendment>.

Take-down policy

If you believe that this document breaches copyright please contact us providing details, and we will remove access to the work immediately and investigate your claim.

Downloaded from the University of Groningen/UMCG research database (Pure): <http://www.rug.nl/research/portal>. For technical reasons the number of authors shown on this cover page is limited to 10 maximum.



- (51) International Patent Classification:
A61N 5/10 (2006.01) G21K 5/10 (2006.01)
- (21) International Application Number:
PCT/EP2017/065100
- (22) International Filing Date:
20 June 2017 (20.06.2017)
- (25) Filing Language: English
- (26) Publication Language: English
- (30) Priority Data:
16183296.9 09 August 2016 (09.08.2016) EP
- (71) Applicant: PAUL SCHERRER INSTITUT [CH/CH];
5232 Villigen PSI (CH).
- (72) Inventors: SCHIPPERS, Jacobus Maarten; Sonnenbergstrasse 15, 5236 Remigen (CH). GERBERSHAGEN, Alexander; Dahlienstrasse 7b, 5200 Brugg (CH).
- (74) Agent: FISCHER, Michael; Siemens AG, Postfach 22 16 34, 80506 München (DE).
- (81) Designated States (unless otherwise indicated, for every kind of national protection available): AE, AG, AL, AM, AO, AT, AU, AZ, BA, BB, BG, BH, BN, BR, BW, BY, BZ, CA, CH, CL, CN, CO, CR, CU, CZ, DE, DJ, DK, DM, DO, DZ, EC, EE, EG, ES, FI, GB, GD, GE, GH, GM, GT, HN, HR, HU, ID, IL, IN, IR, IS, JO, JP, KE, KG, KH, KN, KP, KR, KW, KZ, LA, LC, LK, LR, LS, LU, LY, MA, MD, ME, MG, MK, MN, MW, MX, MY, MZ, NA, NG, NI, NO, NZ, OM, PA, PE, PG, PH, PL, PT, QA, RO, RS, RU, RW, SA, SC, SD, SE, SG, SK, SL, SM, ST, SV, SY, TH, TJ, TM, TN, TR, TT, TZ, UA, UG, US, UZ, VC, VN, ZA, ZM, ZW.

(54) Title: A GANTRY FOR PARTICLE THERAPY AS AN ARM ROTATING IN THE LONGITUDINAL PLANE

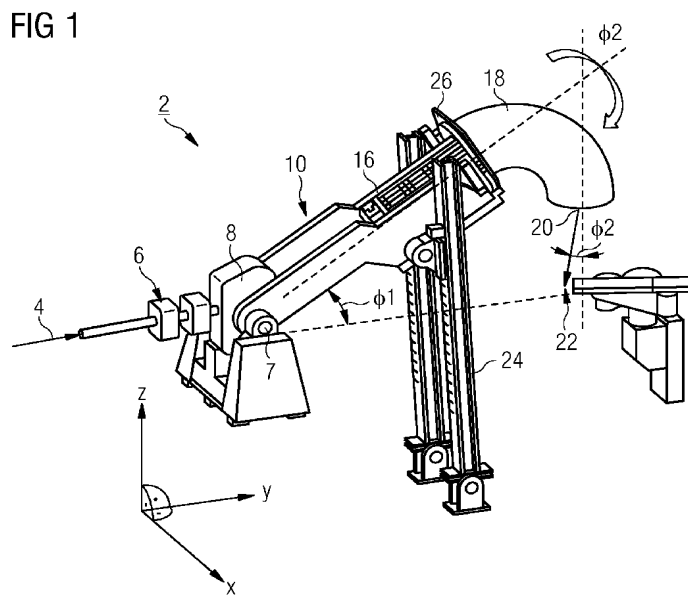

(57) Abstract: The present invention discloses a system (2, 2') for particle beam therapy, comprising as seen in the flow direction of the particle beam (4): a) an adjustable gantry (10, 10') for the beam delivery to a target volume, said gantry comprising: a1) a beam coupling section (6) for the incoming particle beam (4); said incoming particle beam (4) being oriented substantially horizontally thereby defining a horizontal plane; a2) a first beam bending section (8, 8') comprising a number of beam deflection and/or focusing magnets (12, 14) wherein the first bending section (8, 8') either bends the particle beam (4) with an adjustable angle into the vertical plane, or with 90 degrees in the horizontal plane, but with the mechanical possibility to rotate with an adjustable angle along the axis of the incoming particle beam (4); a3) a beam transport section (16) receiving the



(84) Designated States (unless otherwise indicated, for every kind of regional protection available): ARIPO (BW, GH, GM, KE, LR, LS, MW, MZ, NA, RW, SD, SL, ST, SZ, TZ, UG, ZM, ZW), Eurasian (AM, AZ, BY, KG, KZ, RU, TJ, TM), European (AL, AT, BE, BG, CH, CY, CZ, DE, DK, EE, ES, FI, FR, GB, GR, HR, HU, IE, IS, IT, LT, LU, LV, MC, MK, MT, NL, NO, PL, PT, RO, RS, SE, SI, SK, SM, TR), OAPI (BF, BJ, CF, CG, CI, CM, GA, GN, GQ, GW, KM, ML, MR, NE, SN, TD, TG).

Published:

— with international search report (Art. 21(3))

particle beam (4) leaving the first beam bending section (8, 8') and guiding the particle beam (4) to a second beam bending section (18); a4) the second beam bending section (18) comprising a number of beam deflection magnets and/or beam focusing magnets; a5) a beam nozzle (20) comprising a window for the exit of the particle beam (4); and b) a patient table/chair (22) being rotatable in the horizontal plane or in a plane being parallel to the horizontal plane and optionally being adjustable vertically, wherein: c) the gantry (10, 10') is supported by a tilting mechanism(24) allowing the gantry (10, 10') to be tilted vertically by an angle Φ_1 , $\Phi_1 \in [-90^\circ; +90^\circ]$, wherein the gantry (10, 10') comprises a pivot (7, 7') being disposed in the region of the first bending section (8, 8'); and d) a rotation mechanism (26) being disposed in a way that the second beam bending section (18) and the beam nozzle (20) being rotatable by an angle Φ_2 , $\Phi_2 \in [-180^\circ; +180^\circ]$ around a direction given by the angle Φ_1 .

A gantry for particle therapy as an arm rotating in the longitudinal plane

The present invention relates to a gantry for particle.

5

In proton therapy and ion therapy often use is made of a gantry to direct the incident beam from the most optimal angle towards the target (usually a tumor) in the patient. A gantry is a beam transport system (usually comprising magnets) mounted on a mechanical structure that can rotate around the patient who is positioned - often lying but in some cases also sitting on a dedicated treatment table/chair located - at the treatment position. Usually, the rotation range of the gantry is a bit more than 360 degrees, but in some gantries also a bit more than only 180 degrees is used to save space and allow accessing the treatment table/chair at any time during the treatment. Examples for typical rotatable gantries used for proton therapy are disclosed in the European Patent Application 15 194 795.9 and in the International Patent Application WO 2013/149945 A1.

20

The rotatable gantries deliver the dose to be deposited into a cancerous tumor volume at pencil beam resolution for various gantry-orientations which enable a precise dose accumulation in this tumor volume coincidentally preventing healthy tissue in the surrounding of the tumor volume from damage due to the beam stopping effect which materializes in the so-called Bragg Peak. Nevertheless, these gantries of the form of a C-arm require a considerable space to allow its rotation of a system that involves the weight of ten of tons. At each gantry angle a very accurate positioning of the beam delivery components (in particular the sweeper magnets and the last beam bending magnet(s)) is needed in order to obtain the desired beam characteristics, like the beam energy and beam position and beam direction.

35

It is therefore the objective of the present invention to provide a system that replaces the current rotatable gantries for particle beam therapy and that provides a significantly simpler set-up and allowing at least the flexibility in beam delivery known from the prior art gantries. Compared to the currently used rotatable gantries the advantages of the present invention shall also provide a lower weight of the system and a smaller space needed.

- 10 This objective is achieved according to the present invention by a system for particle beam therapy, comprising as seen in the flow direction of the particle beam:
- a) an adjustable gantry for the beam delivery to a target volume, said gantry comprising:
 - 15 a1) a beam coupling section for the incoming particle beam; said incoming particle beam being oriented substantially horizontally thereby defining a horizontal plane;
 - a2) a first beam bending section comprising a number of beam deflection and/or focusing magnets; said first bending section 20 either bending the beam with an adjustable angle into the vertical plane, or with 90 degrees in the horizontal plane, but with the mechanical possibility to rotate with an adjustable angle along the axis of the incoming particle beam;
 - a3) a beam transport section receiving the particle beam leaving 25 the first beam bending section and guiding the particle beam to a second beam bending section;
 - a4) the second beam bending section comprising a number of beam deflection magnets and/or beam focusing magnets;
 - a5) a beam nozzle comprising a window for the exit of the 30 particle beam; and
 - b) a patient table/chair being rotatable and/or shiftable in the horizontal plane or in a plane being parallel to the horizontal plane and optionally being adjustable vertically, wherein:

- c) the gantry is supported by a tilting mechanism allowing the gantry to be tilted vertically by an angle Φ_1 with respect to the horizontal plane, $\Phi_1 \in [-90^\circ; +90^\circ]$, wherein the gantry comprises a pivot being disposed in the region of the beam coupling section; and
- 5 d) a rotation mechanism being disposed in a way that the second beam bending section and the beam nozzle being rotatable by an angle Φ_2 , $\Phi_2 \in [-180^\circ; +180^\circ]$ around a direction given by the angle Φ_1 .
- 10 The advantages of this system layout are a reduction of the treatment room footprint with respect to that of a conventional gantry according to the prior art and a very simple mechanical construction to move second beam bending section up and down. Further, it is possible to mount a degrader and/or a beam
- 15 scanning system in the beam transport section between the first beam bending section and the second beam bending section whereas the scanning system may be mounted in the nozzle downstream of the second beam bending section. Furthermore, compared with conventional gantries two rotational axes allow additional
- 20 freedom in the choice of how a treatment angle is constructed and how the eventual misalignments can be corrected.

- With respect to a geometrical set-up of the system that can be easily implemented and/or maintained, i.e. for quality control,
- 25 the following basic settings can be chosen:
- a) maximum of Φ_1 and $\Phi_2 = 0^\circ$ lead to a particle beam pointing from the vertical direction downwards to the patient table/chair;
- b) minimum of Φ_1 and $\Phi_2 = 180^\circ$ lead to a particle beam pointing from the vertical direction upwards to the patient table/chair;
- 30 c) $\Phi_1 = 0^\circ$ and $\Phi_2 = 90^\circ$ lead to a particle beam pointing in the horizontal direction from one side to the patient table/chair; and
- d) $\Phi_1 = 0^\circ$ and $\Phi_2 = 90^\circ$ and a rotation of the patient table/chair of 180° in the horizontal plane lead to a particle beam pointing

in the horizontal direction from the other side to the patient table/chair.

These settings allow to "play" with the beam orientation according to the needs and demands of the therapy plan and to get
5 back easily to one of the position according to the basic settings a) to d). The settings therefore allow an extension of the range of Φ_2 into $[180^\circ; +180^\circ]$

10 The tilting angle of Φ_2 can preferably range from 0° to $+180^\circ$, so that the isocenter and the patient table/chair are always at the same side of the gantry. In this way, the footprint of the gantry is minimized.

15 In order to realize a mechanical set-up that can be controlled in a non-complicated way, the tilting mechanism may comprise a telescope arm or a lifting mechanism based on one or two chains along the lifting arm.

20 Further, the beam transport section may comprise a telescope section, too. This enables the operator during the tilting to maintain the position in terms of the point (isocenter of the system) of the beam passing through the horizontal plane. Herein, it is suitable when the beam transport section can be adjustable in length in order to compensate the change in the horizontal
25 component of the gantry due to the tilting. In this way, the isocenter will be located on a straight line, perpendicular to the direction of the beam after the first bending section.

30 At some installations it might not be possible to deliver the particle beam right in the direction required for the first and/or second bending section. It is therefore helpful when the first beam bending section may comprise a set of magnets that also deflect in the horizontal plane. The first bending section itself can also rotate mechanically over an axis that coincides
35 with the incoming beam direction. The combination of the 90

degrees deflection due to the magnetic fields in the first bending section and the mechanical rotation of the first beam bending section defines the gantry's first angle Φ_1 . Therefore, the first beam bending section is capable to bend the beam not only in the direction given by the first angle Φ_1 but also into a further direction, i.e. within the horizontal plane in which the beam is delivered after its generation, i.e. in a cyclotron.

In a preferred embodiment the system may additionally comprise a beam spreading system to spread the beam in the lateral direction, which is perpendicular to the direction of the beam leaving the second bending section. The beam spreading system can comprise a scattering system that increases the beam diameter and/or a system of fast deflection magnets that scan the beam in the transversal direction. The beam spreading system can be collated before (upstream of) or behind (downstream of) the second bending section.

Preferred embodiments of the present invention are hereinafter described in more detail with reference to the attached drawings which depict in:

Figure 1 schematically a perspective view on a first system for particle therapy;

Figure 2 schematically a perspective view on a second system for the particle therapy that is only slightly amended as compared to Figure 1;

Figure 3 schematically the position of the system according to Figure 1 when the particle beam is led vertically downwards (a) and vertically upwards (b); and

Figure 4 schematically the position of the system according to Figure 1 when the particle beam is led horizontally

from one side; (a) is a view from the side and (b) is the view from above.

Fig. 1 schematically shows a first system 2 for particle beam therapy delivery. The system 2 comprises for an incoming particle beam 4 a beam coupling section 6 being followed by a first bending section 8. In the present example, a gantry 10 is supported by a tilting mechanism 24 allowing the gantry 10 to be tilted vertically (along the z-axis) by an first angle Φ_1 , $\Phi_1 \in [-90^\circ; +90^\circ]$, wherein the gantry 10 comprises the bearing (pivot) 7 being disposed at the entrance of the beam coupling section 6 in order to enable a declination of the complete gantry 10 in the z-direction. The first bending section 8 bends the particle beam 4, such as a proton beam or an ion beam, in the vertical yz plane with an angle Φ_1 .

Further, a second bending section 18 and a beam nozzle 20 can be rotated by a rotation mechanism 26 being disposed in a way that the second beam bending section 18 and the beam nozzle 20 being rotatable by an angle Φ_2 , $\Phi_2 \in [-180^\circ; +180^\circ]$ around a direction given by the angle Φ_1 , but preferably $\Phi_2 \in [0^\circ; +180^\circ]$, to limit the footprint of the gantry.

In addition, a beam transport section 16 connecting the first beam bending section 8 to the second bending section 18 can be telescopically adjustable with respect to the length of this beam transport section 16 and allows a variation in length of approximately 0.5 m.

In the shown example, the second beam bending section 18 bends the beam by a fixed angle in the range of 90-135 degrees. This second bending section 18 is rotatable along an axis that approximately equals the direction given by Φ_1 of the unscanned (or central) beam entering the second beam bending section 18. This rotation angle Φ_2 covers at least 180 degrees, between 0

degr. (aiming the beam downwards) and +180 degr (aiming upwards). The appropriate value for Φ_2 is a function of Φ_1 . The combination of Φ_1 and Φ_2 determines the incident angle of the beam direction at the patient.

5

The following three main incident direction can be established:

- When Φ_1 is maximal (+) and $\Phi_2 = 0^\circ$, the particle beam 4 points from the vertical direction down to the patient (see Figure 3(a)).
- 10 • When Φ_1 is minimal (-) and $\Phi_2 = 180^\circ$, the particle beam 4 points in the vertical direction upwards to the patient (see Figure 3(b)).
- When $\Phi_1 = 0^\circ$ and $\Phi_2 = 90^\circ$, the particle beam 4 points in the horizontal direction to the patient (see Figure 4
- 15 (a) and (b)).

In all orientations small deviations can be added to Φ_1 and Φ_2 by small bending magnets (steering magnets) for fine tuning the incident angle at the patient. A nozzle 20 at the exit of the second bending section 18 can comprise equipment to verify the applied dose and the beam characteristics. A patient table 22 is part of a positioning system that can shift and rotate the patient position in the horizontal plane. The range of this adjustment must be large enough to compensate the motion of the isocenter as a function of Φ_1 and Φ_2 .

In order to have a common understanding on the direction, the following definitions are applied:

- The *horizontal plane* is the plane at the height of the particle beam 4 exiting the second beam bending section 18, when Φ_1 is at 0° . This is usually equal to the level of the incoming particle beam 4 at the coupling section 6.
- The *treatment angle* is the angle of the particle beam at the isocenter with respect to the patient orientation and it is

determined by a combination of the Φ_1 and Φ_2 and the orientation of the patient table/chair 22.

- The *isocenter* is the location where the beam coming out of the nozzle 20 is crossing the *horizontal plane*. Typically, Φ_2 is determined by the value of Φ_1 but can be chosen differently in case of exceptional treatment angles or treatment target locations.

10 The components from the beam transport section 16 until and including the second beam bending section 18 are mounted such that these are always aligned in a mechanical stable or corrected position. The isocenter position is not fixed in space and moves along a curve in the horizontal plane as a function of Φ_1 . The
15 shape of this curve depends on whether use is made of the option to have an adjustable (telescopic) length of the beam transfer section 16 which is located between the first beam bending section 10 and the second beam bending section 18. In that case, the length of this beam transport section 16 is a function of Φ_1 .
20 This option enables that the isocenter position moves along a straight line in the horizontal plane. This is advantageous for daily checks and in connection to imaging devices that verify the patients positioning with respect to the gantry. However, with appropriate tools for these checks, a curved trajectory of the
25 isocenter position as a function of Φ_1 and Φ_2 is also possible.

The second beam bending section 18 can be designed such that it rotates over a Φ_2 range of >360 degrees or >180 degrees. The 180 degrees version has major advantages, such as a smaller treatment
30 room, less moving range of the patient table 22 and easier rotation construction. This is the version shown in the figures.

Possible advantages of here proposed mechanical layout are:

- a reduction of the treatment room footprint with respect to
35 that of a conventional gantry;

- very simple mechanical construction to move the second beam bending section 18 up and down;
- it is possible to mount a degrader and/or scanning system (sweeper magnets) in the beam transfer section 16 between the first bending section 8 and the second beam bending section 18 or the beam scanning system can be mounted in the nozzle 20 of the second beam bending section 18;
- Compared with conventional gantries the two rotational axes allow one additional degree of freedom in the choice of how a treatment angle is constructed.

Figure 2 schematically shows a system 2' for a therapy using the particle beam 4 that is slightly amended as compared to the system 2. Presently, the particle beam 4 which is generated in a linear accelerator and/or a cyclotron and/or a synchrotron is delivered horizontally along the x-direction to a particle beam gantry - in the following referred to as gantry 10'. Said gantry 10' comprises a coupling section 6. At this coupling section 6, the gantry 10 can be rotated over an angle Φ_1 along the x-axis by a rotation bearing 7'. Beside this rotation bearing 7', the coupling section 6 provides beam focusing (collimators) and beam control/diagnosis equipment (not shown in detail) before the particle beam 4 enters into a first bending section 8'. Usually, this first bending section 8' comprises a number of dipole and/or quadrupole magnets 12, 14 which are controlled to bend the particle beam 4 by its magnetic fields into a desired direction. In the present example, the first beam bending section 8' bends the particle beam 4 from the x-direction into the y-direction, so over an angle of 90 degrees in the horizontal plane, if the first bending section 8' is not rotated.

The first beam bending section 8' is followed by the beam transport section 16 receiving the particle beam 4 leaving the first beam bending section 8' and guiding the particle beam 4 to a second beam bending section 18. The beam transport section 16

may comprise further equipment for the beam diagnosis and sweeper magnets as for example known from the WO 2013/149945 A1.

5 The second beam bending section 18 comprises a number of beam deflection magnets and/or beam focusing magnets in order to deliver the particle beam 4 via the beam nozzle 20 comprising a window for the exit of the particle beam 4 out of the gantry 10' to the patient table 22. The patient table 22 could also comprise a patient chair allowing a patient to be treated in upright
10 position. The patient table/chair 22 is rotatable and/or shiftable in the horizontal plane (given here by the x- and y-axis). Optionally, the patient table/chair may be adjustable vertically, too.

15 In the present example, the gantry 10' is supported by the tilting mechanism 24 allowing the gantry 10' to be tilted vertically (along the z-axis, in the yz-plane) by a first angle Φ_1 , $\Phi_1 \in [-90^\circ; +90^\circ]$, wherein the gantry 10' comprises the rotation bearing (pivot) 7' being disposed at the entrance of the
20 beam coupling section 6 in order to enable a rotation of the complete gantry 10' along the x-axis. Further, the second bending section 18 and the beam nozzle 20 can be rotated by the rotation mechanism 26 being disposed in a way that the second beam bending section 18 and the beam nozzle 20 being rotatable by an angle Φ_2 ,
25 $\Phi_2 \in [-180^\circ; +180^\circ]$, but preferably $\Phi_2 \in [0^\circ; +180^\circ]$ in order to limit the footprint of the gantry 10') around a direction given by the angle Φ_1 .

Typically, the range of the first angle Φ_1 depends on the design
30 of the system 2'. For the system 2', the range of the first angle Φ_1 can typically be between approximately -40° and $+40^\circ$. After the first bending section 8' the out-coming beam 4 is aimed into the Φ_1 -direction with respect to the horizontal plane: downwards when $\Phi_1 < 0$ and upwards when $\Phi_1 > 0$. Due to the bending in the

horizontal plane, the first bending section 8' can be designed such that it can also serve as an energy selection system.

5

Patent Claims

1. A system (2, 2') for particle beam therapy, comprising as seen in the flow direction of the particle beam (4):
- 5 a) an adjustable gantry (10, 10') for the beam delivery to a target volume, i.e. malign tissue of a patient, said gantry (10, 10') comprising:
- a1) a beam coupling section (6) for the incoming particle beam (4); said incoming particle beam (4) being oriented substantially
- 10 horizontally thereby defining a horizontal plane;
- a2) a first beam bending section (8, 8') comprising a number of beam deflection and/or focusing magnets (12, 14); said first bending section (8, 8') either bending the particle beam (4) with an adjustable angle into the vertical plane, or with 90 degrees
- 15 in the horizontal plane, but with the mechanical possibility to rotate with an adjustable angle along the axis of the incoming particle beam (4);
- a3) a beam transport section (16) receiving the particle beam (4) leaving the first beam bending section (8, 8') and guiding the
- 20 particle beam (4) to a second beam bending section (18);
- a4) the second beam bending section (18) comprising a number of beam deflection magnets and/or beam focusing magnets;
- a5) a beam nozzle (20) comprising a window for the exit of the particle beam (4); and
- 25 b) a patient table/chair (22) being rotatable and/or shiftable in the horizontal plane or in a plane being parallel to the horizontal plane and optionally being adjustable vertically, wherein:
- c) the gantry (10, 10') is supported by a tilting mechanism (24)
- 30 allowing the gantry (10, 10') to be tilted vertically by an angle Φ_1 , $\Phi_1 \in [-90^\circ; +90^\circ]$, wherein the gantry (10, 10') comprises a pivot (7, 7') being disposed in the region of the first beam bending section (8, 8'); and
- d) a rotation mechanism (26) being disposed in a way that the
- 35 second beam bending section (18) and the beam nozzle (20) being

rotatable by an angle Φ_2 , $\Phi_2 \in [-180^\circ; +180^\circ]$ around a direction given by the angle Φ_1 .

2. The system according to claim 1, wherein the following basic settings are chosen:
 - a) maximum of Φ_1 and $\Phi_2 = 0^\circ$ lead to a particle beam (4) pointing from the vertical direction downwards to the patient table/chair (22);
 - b) minimum of Φ_1 and $\Phi_2 = 180^\circ$ lead to a particle beam (4) pointing from the vertical direction upwards to the patient table/chair (22);
 - c) $\Phi_1 = 0^\circ$ and $\Phi_2 = -90^\circ$ lead to a particle beam (4) pointing in the horizontal direction from one side to the patient table/chair (22); and
 - d) $\Phi_1 = 0^\circ$ and $\Phi_2 = +90^\circ$ lead to a particle beam (4) pointing in the horizontal direction from the other side to the patient table/chair (22).
3. The system according to claim 1 or 2, wherein the tilting mechanism (24) comprises a telescope arm.
4. The system according to any of the preceding claims wherein the beam transport section (16) comprises a telescope section.
5. The system according to claim 4, wherein the beam transport section (16) is adjustable in length in order to compensate the change in the horizontal component of the gantry (10, 10') due to the tilting angle Φ_1 .
6. The system according to any of the preceding claims wherein the first beam bending section (8, 8') comprises a set of magnets in order to deflect the incoming beam into the direction given by the first angle Φ_1 .

7. The system according to any of the preceding claims wherein a beam spreading system is provided to spread the beam in the lateral direction, which is perpendicular to the direction of the beam leaving the second bending section (18); said beam spreading system preferably comprising a scattering system that increases the beam diameter and/or a system of fast deflection magnets that scan the beam in the transversal direction wherein the beam spreading system can be collated before (upstream of) or behind (downstream of) the second bending section (18).

10

FIG 1

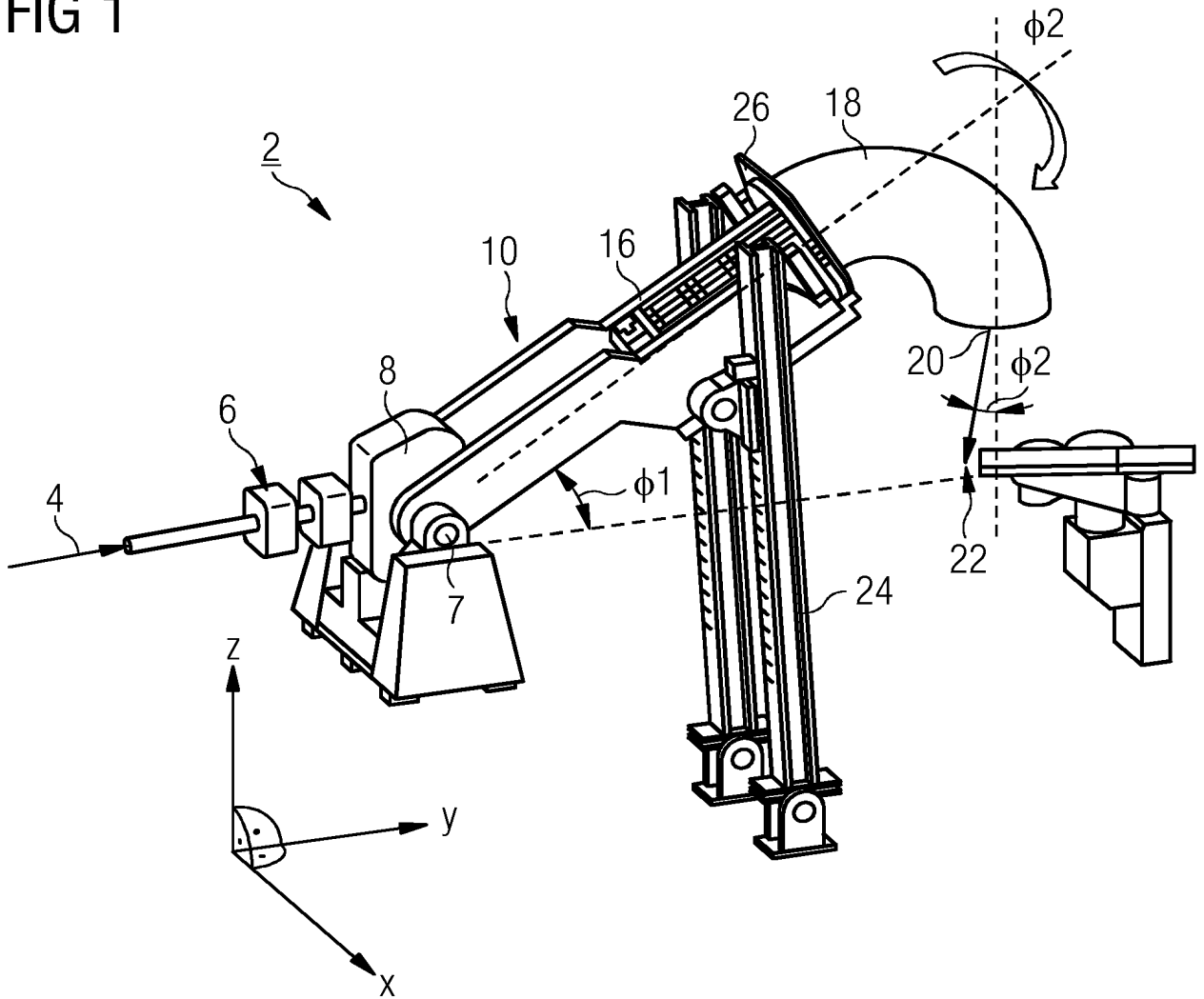

FIG 2

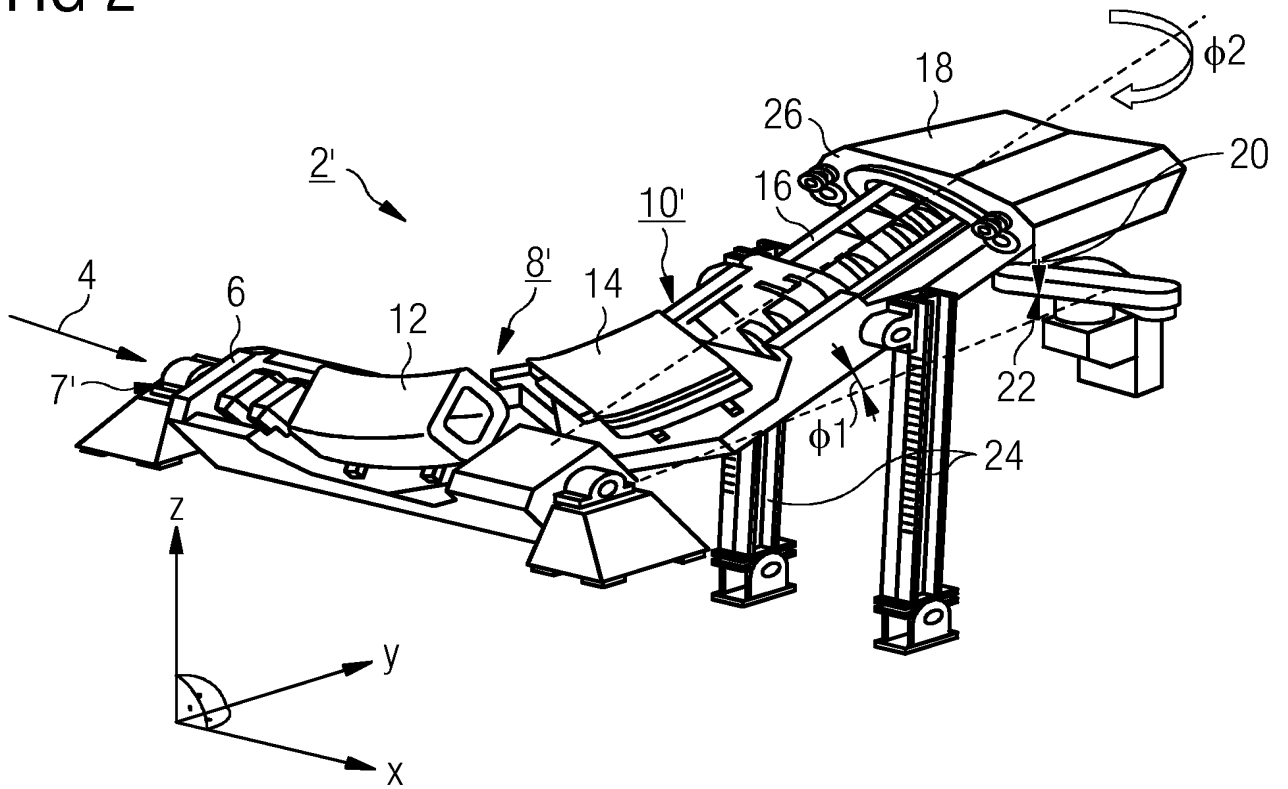
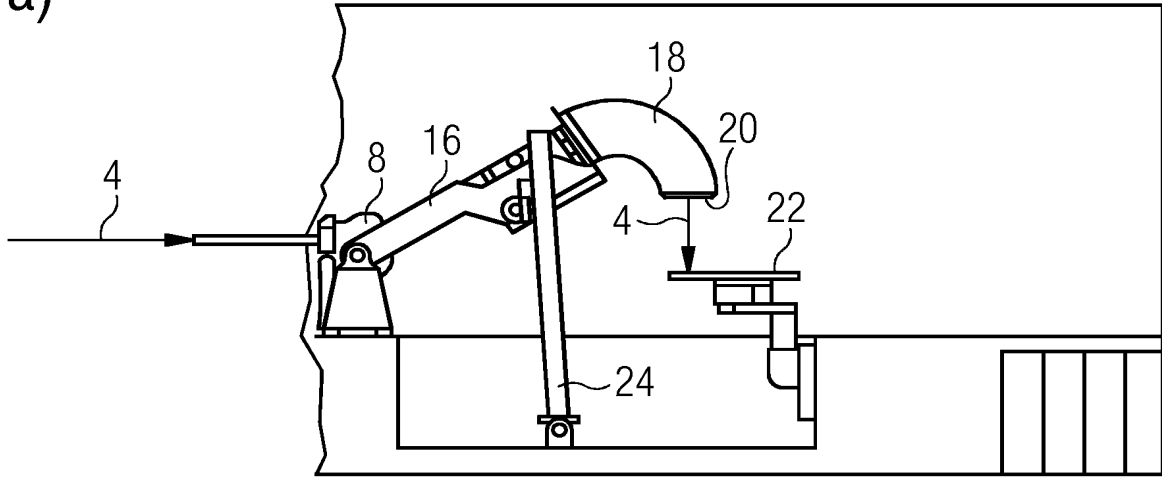

FIG 3

a)



b)

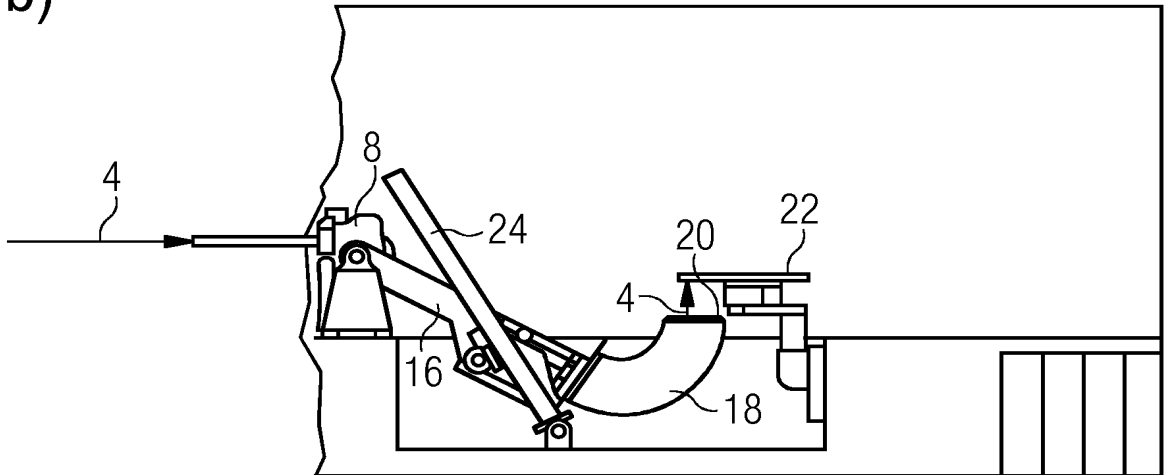
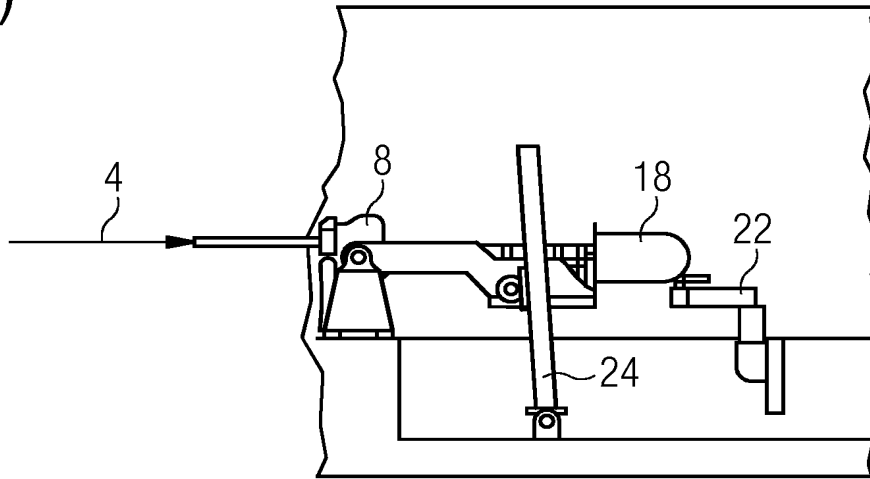
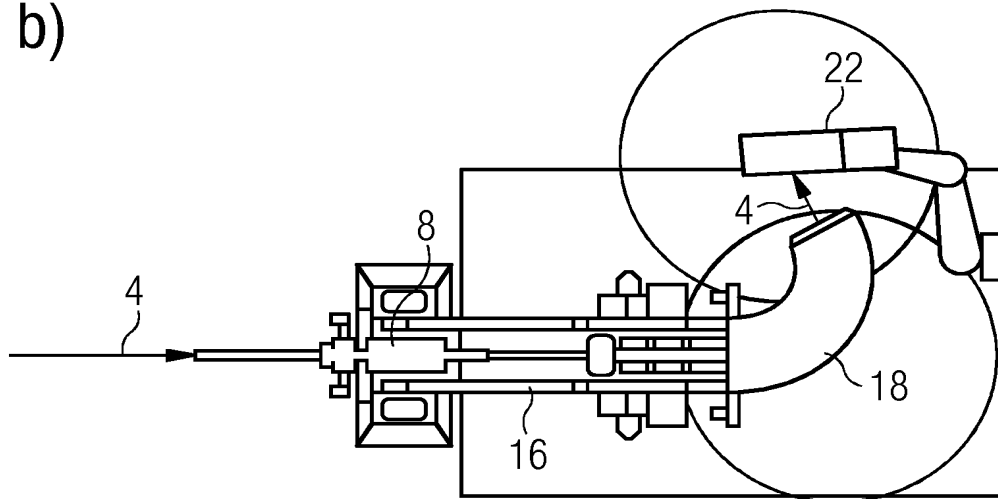

FIG 4
a)



b)



INTERNATIONAL SEARCH REPORT

International application No
PCT/EP2017/065100

A. CLASSIFICATION OF SUBJECT MATTER
 INV. A61N5/10 G21K5/10
 ADD.
 According to International Patent Classification (IPC) or to both national classification and IPC

B. FIELDS SEARCHED
 Minimum documentation searched (classification system followed by classification symbols)
 A61N G21K
 Documentation searched other than minimum documentation to the extent that such documents are included in the fields searched

Electronic data base consulted during the international search (name of data base and, where practicable, search terms used)
 EPO-Internal, WPI Data

C. DOCUMENTS CONSIDERED TO BE RELEVANT

Category*	Citation of document, with indication, where appropriate, of the relevant passages	Relevant to claim No.
A	EP 2 886 158 A1 (VARIAN MEDICAL SYSTEMS PARTICLE THERAPY GMBH [DE]) 24 June 2015 (2015-06-24) paragraphs [0001], [0006], [0009], [0030]; claims 1,8; figures 1-10 -----	1-7
A	US 2011/150186 A1 (ZIEGLER CHRISTIAN [DE] ET AL) 23 June 2011 (2011-06-23) paragraph [0025]; figure 1 -----	1-7
A	WO 00/74779 A1 (SCANDITRONIX MEDICAL AB [SE]; NAEFSTADIUS PEDER [SE]) 14 December 2000 (2000-12-14) claims 1-4; figures 1,11 -----	1-7

Further documents are listed in the continuation of Box C.

See patent family annex.

* Special categories of cited documents :

<p>"A" document defining the general state of the art which is not considered to be of particular relevance</p> <p>"E" earlier application or patent but published on or after the international filing date</p> <p>"L" document which may throw doubts on priority claim(s) or which is cited to establish the publication date of another citation or other special reason (as specified)</p> <p>"O" document referring to an oral disclosure, use, exhibition or other means</p> <p>"P" document published prior to the international filing date but later than the priority date claimed</p>	<p>"T" later document published after the international filing date or priority date and not in conflict with the application but cited to understand the principle or theory underlying the invention</p> <p>"X" document of particular relevance; the claimed invention cannot be considered novel or cannot be considered to involve an inventive step when the document is taken alone</p> <p>"Y" document of particular relevance; the claimed invention cannot be considered to involve an inventive step when the document is combined with one or more other such documents, such combination being obvious to a person skilled in the art</p> <p>"&" document member of the same patent family</p>
---	---

Date of the actual completion of the international search 21 August 2017	Date of mailing of the international search report 18/09/2017
--	---

Name and mailing address of the ISA/ European Patent Office, P.B. 5818 Patentlaan 2 NL - 2280 HV Rijswijk Tel. (+31-70) 340-2040, Fax: (+31-70) 340-3016	Authorized officer Kajzar, Anna
--	---

INTERNATIONAL SEARCH REPORT

Information on patent family members

International application No PCT/EP2017/065100

Patent document cited in search report	Publication date	Patent family member(s)	Publication date	
EP 2886158	A1	24-06-2015	CN 105517630 A	20-04-2016
			EP 2886158 A1	24-06-2015
			EP 3153211 A1	12-04-2017
			JP 2017503625 A	02-02-2017
			US 2016279447 A1	29-09-2016
			WO 2015090555 A1	25-06-2015

US 2011150186	A1	23-06-2011	CN 102548612 A	04-07-2012
			DE 102010032131 A1	27-01-2011
			US 2011150186 A1	23-06-2011
			WO 2011009616 A1	27-01-2011

WO 0074779	A1	14-12-2000	AU 5434400 A	28-12-2000
			CN 1433333 A	30-07-2003
			EP 1218062 A1	03-07-2002
			US 6969194 B1	29-11-2005
			WO 0074779 A1	14-12-2000
