



Absorption of coal combustion flue gases in ionic liquids using different membrane contactors

Jonathan Albo*, Patricia Luis, Angel Irabien

*Universidad de Cantabria, Ingeniería Química y Química Inorgánica, Avenida de los Castros s/n. ES-39005 Santander, Spain
Tel. +34 942 206777; email: jonathan.albo@unican.es*

Received 31 May 2010; Accepted 28 October 2010

ABSTRACT

Carbon dioxide (CO₂) and sulfur dioxide (SO₂) are typical gases produced during coal combustion and their emissions have to be controlled and minimized in order to reduce environmental risks. Organic solvents are commonly used as absorption liquids for the chemical absorption of CO₂ and SO₂, and their use in combination with a membrane device is being studied recently. The volatile character of common solvents produces solvent losses due to their evaporation into the gas stream. Thus, the use of solvents with lower vapor pressure such as ionic liquids as absorption liquids may contribute to the performance of a zero solvent emission process. In the present study, mass transfer of CO₂ is studied in a polypropylene hollow fiber membrane contactor when the ionic liquid 1-ethyl-3-methylimidazolium ethylsulfate is used as the absorption liquid. Mass transfer coefficients are compared with those obtained with a ceramic hollow fiber contactor for SO₂ absorption. The overall mass transfer coefficient takes a value of $K_{\text{overall}} = (3.69 \pm 0.18) \times 10^{-7} \text{ m s}^{-1}$ and $K_{\text{overall}} = (3.38 \pm 0.09) \times 10^{-6} \text{ m s}^{-1}$ in CO₂ and SO₂ systems, respectively. Main resistance to mass transfer has been found to be the membrane itself. In CO₂ absorption a theoretical effective diffusivity was estimated as $D_{\text{eff}} = 4.94 \times 10^{-7} \text{ m}^2 \text{ s}^{-1}$ which differs from diffusivity obtained from experimental results ($D_{\text{eff}} = (1.717 \pm 0.18) \times 10^{-11} \text{ m}^2 \text{ s}^{-1}$).

Keywords: Carbon dioxide; Sulfur dioxide; Non-dispersive absorption; Gas-liquid membrane contactors; Ionic liquids; Process intensification

1. Introduction

Process intensification offers significant improvements in chemical manufacturing and processing, leading to cheaper, safer and sustainable technologies [1]. CO₂ capture and storage (CCS), which involves the processes of capture, transport and long-term storage of CO₂, is a technology aimed at reducing greenhouse gas emissions. However, CO₂ capture is the bottleneck step where efforts have to be applied in order to develop technically and economically available processes. Other gases, such as, SO₂, have to be also removed but waste

production or solvent losses associated to the industrial processes currently used for their recovery makes necessary process intensification.

The use of scrubbers and other systems where a direct contact between the gas stream and the absorption liquid occurs produces economic and environmental drawbacks due to drops dragging and solvent evaporation. Previous works [2,3] showed that process intensification can be performed in two steps to develop a zero solvent emission process: first by the substitution of the equipment for a membrane device avoiding drops dragging [4] and secondly by the substitution of the absorption liquid for a solvent with lower vapor pressure (e.g., ionic liquids) [2].

*Corresponding author.

Ionic liquids (ILs) are salts with a melting point lower than 100°C and with a negligible vapor pressure, features that turn them into very interesting solvents in the industry. Some ionic liquids have been found to have high solubility capacity of CO₂ and SO₂ and are recently under study as potential absorption liquids [5,6].

Many studies have characterized mass transfer behavior for gas absorption into different absorbents liquids and different hollow fiber membrane materials [7–11] considering resistances in gas, liquid and membrane phase [12–14]; the membrane resistance depends on diffusivity of absorbing gas and geometrical membrane characteristics [15–17]. In this work, a commercial polypropylene hollow fiber membrane contactor (Liquicel®) for CO₂ recovery is used as the membrane device to evaluate the process efficiency and mass transfer when the ionic liquid 1-ethyl-3-methylimidazolium ethylsulfate is used as the absorption liquid. The mass transfer through the membrane contactor is compared with that obtained when a ceramic hollow fiber contactor (Hyflux®) is used for SO₂ recovery [2,3], and it is evaluated in terms of the applicability for reaching a specific target of CO₂ recovered.

2. Mass transfer

Assuming membrane with gas-filled pores, overall mass transfer coefficient, $K_{overall}$, can be split into a combination of resistances for membrane phase, k_m , liquid phase, k_l , and gas phase, k_g in a resistance-in-series model [12–14]. Considering chemical reaction in the liquid side (expressed by the enhancement factor, E) the equation is the following Ref. [18].

$$\frac{1}{K_{overall}} = \frac{1}{k_g} + \frac{d_o}{k_m \cdot d_{lm}} + \frac{H \cdot d_o}{k_l \cdot d_i \cdot E} \quad (1)$$

where d_o , d_i and d_{lm} are the outside, inside and log mean diameters in (m) of the hollow fibre and k_m is the membrane mass transfer coefficient (m · s⁻¹).

For gas flowing outside parallel to the hollow fiber, the mass transfer coefficient can be estimated from Ref. [18]:

$$\frac{k_g \cdot d_h}{D_{CO_2,b}} = 1.25 \cdot \left(\frac{d_h^2 \cdot v_g}{L \cdot v} \right)^{0.93} \cdot \left(\frac{v}{D_{CO_2,b}} \right)^{1/3} \quad (2)$$

where d_h is the hydraulic diameter (m); $D_{CO_2,b}$ is the diffusion coefficient of the gas phase (m² · s⁻¹); L is the fibre length (m); and v (m² · s⁻¹) is the kinematic viscosity. When the flow inside the hollow fiber is laminar, the

mass transfer coefficient of liquid phase is given by the Lévêque equation [18]:

$$\frac{k_l \cdot d_i}{D_{CO_2,l}} = 1.62 \cdot \left(\frac{d_i^2 \cdot v_l}{L \cdot D_{CO_2,l}} \right)^{1/3} \quad (3)$$

where d_i is the internal fibre diameter (m), and $D_{CO_2,l}$ is the diffusion coefficient in the liquid phase (m² · s⁻¹)

3. Experimental

3.1. Materials and methods

Basically, it consisted of a gas mixture containing sulfur dioxide (10 ± 0.02 vol.%), oxygen (21 ± 0.02 vol.%) and nitrogen (rest to balance). Air was used to dilute the gas stream. A ceramic hollow fibre membrane contactor was used with the features shown in Table 1. The ionic liquid 1-ethyl-3-methylimidazolium ethylsulfate ([EMIM][EtSO₄] or EMISE) was used as absorption liquid due to its low viscosity, low toxicity, and low cost [6]. Materials and methods for SO₂ absorption have been described previously [2].

For CO₂ absorption 1-ethyl-3-methylimidazolium ethylsulfate ([EMIM][EtSO₄] or EMISE) was also used as the absorption liquid. It was supplied by Green Solutions (Vigo, Spain). Carbon dioxide (99.7 ± 0.01 vol.%), was obtained from Air Liquide (Spain) and pure nitrogen (99.999 ± 0.001 vol.%) from Air Liquide (Spain) was used to dilute gas stream.

The hydrophobic hollow fiber contactor was supplied by Liquicel® Membrane Contactors (USA). According to the commercial specifications, the microporous hollow fiber membrane is a thin wall, opaque, symmetric, polypropylene membrane with a nominal internal diameter of 220 microns. Wall thickness is 40 microns. The pore size of the fiber is 0.04 microns,

Table 1
Hollow fiber membrane contactor comparison

	CO ₂ recovery	SO ₂ recovery
Membrane material	Polypropylene	α-Al ₂ O ₃
Fiber o.d. d_o (m)	3 × 10 ⁻⁴	4 × 10 ⁻³
Fiber i.d. d_i (m)	2.2 × 10 ⁻⁴	3 × 10 ⁻³
Fiber length, L (m)	0.115	0.44
Number of fibers, n	2300	280
Effective inner membrane area, A (m ²)	0.18	0.1
Membrane thickness, δ (m)	0.4 × 10 ⁻⁴	5 × 10 ⁻⁴
Membrane pore diameter, d_p (μm)	0.04	0.1

and the porosity is 40% ($\epsilon = 0.4$). Potting and housing materials were polyurethane and polycarbonate, respectively. In the hollow fiber membrane contactor, the gas stream flows through the shell side and the absorption liquid flows counter currently through the inside of the hollow fibers. In Table 1, this contactor is compared with the ceramic contactor used for SO_2 absorption [2].

The composition of the feed gas stream ranged from 8 to 41 vol.% CO_2 and N_2 (rest to balance). The range of experimental conditions is shown in Table 2 and the experimental setup for CO_2 absorption is shown in Fig. 1, while for SO_2 has been described in a previous work [2].

Table 2
Experimental conditions in the membrane gas absorption contactor

[EMIM][EtSO ₄]	CO_2 recovery	SO_2 recovery
Pressure at the inlet of gas line (bar gauge)	0	0
Pressure at the inlet of liquid line (bar gauge)	0.200	0.125
Pressure drop (gas line) (bar)	0	0.02
Pressure drop (liquid line) (bar)	0.195	0.095
Composition of feed gas stream (vol.%)		
CO_2/SO_2	8–41	3.3
N_2/Air	$\text{N}_2/\text{Rest to balance}$	$\text{Air}/\text{Rest to balance}$
Temperature (K)	288 ± 1	289 ± 1
Gas flow rate ($\text{l} \cdot \text{min}^{-1}$)	0.01	1
Liquid flow rate ($\text{l} \cdot \text{min}^{-1}$)	0.05	1

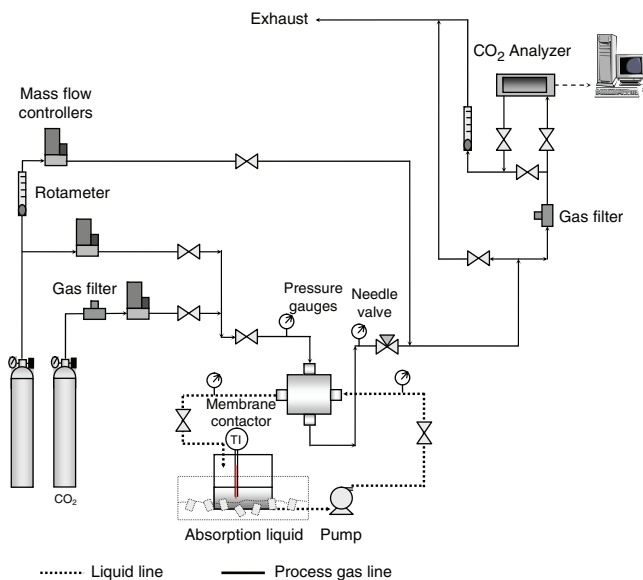

Fig. 1. Schematic drawing of experimental setup.

The feed gas stream was adjusted by means of mass flow controllers (Brook Instrument MFC 5850, Emerson Process Management, Spain), which allows the control and measurement of the gas flow. Pressure gauges at the inlet and outlet of the contactor show the gas pressure, while a needle valve was installed at the outlet in order to maintain the desired pressure, if necessary. The absorption liquid was pumped from the storage tank. The control and measurement in the liquid line was carried out by a digital gear pump (Cole Parmer Instrument Company, Hucoa-Erloss S.A, Spain), which permits the control of the liquid flow. A valve was used at the outlet to prevent accidental passing of gas bubbles into the liquid. The measurement of pressure in the liquid line was similar to that in the gas line.

Mass transfer flux of carbon dioxide in the gas phase has been calculated according to this equation:

$$N_{\text{CO}_2, g} = \frac{Q_g}{A} (C_{\text{CO}_2(g), \text{in}} - C_{\text{CO}_2(g), \text{out}}) \quad (4)$$

where Q_g is the gas flow rate ($\text{m}^3 \cdot \text{s}^{-1}$) and A is the membrane area (m^2).

The overall mass transfer coefficient, K_{overall} ($\text{m} \cdot \text{s}^{-1}$) can be experimentally evaluated from the flux through the membrane:

$$N_{\text{CO}_2, g} = K_{\text{overall}} \cdot \frac{\Delta y_{lm} \cdot P_T}{R \cdot T} \quad (5)$$

P_T is the total pressure in the gas phase (atm) and Δy_{lm} is the logarithmic mean of the driving force based on gas phase molar fractions and taking into account the carbon dioxide concentration in the inlet ($y_{\text{CO}_2(g), \text{in}}$) and the outlet ($y_{\text{CO}_2(g), \text{out}}$) of the contactor:

$$\Delta y_{lm} = \frac{(y_{\text{CO}_2(g), \text{in}} - y_{\text{in}}^*) - (y_{\text{CO}_2(g), \text{out}} - y_{\text{out}}^*)}{\ln((y_{\text{CO}_2(g), \text{in}} - y_{\text{in}}^*) / (y_{\text{CO}_2(g), \text{out}} - y_{\text{out}}^*))} \quad (6)$$

Assuming that carbon dioxide concentration in the solvent is very far from the saturation in the experiments, the influence of the gas–liquid equilibrium has been neglected: $y_{\text{in}}^* \approx y_{\text{out}}^* \approx 0$. In addition, the CO_2 removal efficiency (%) is defined as:

$$\text{Efficiency} = \left(1 - \frac{C_{\text{CO}_2(g), \text{out}}}{C_{\text{CO}_2(g), \text{in}}} \right) \times 100 \quad (7)$$

4. Results and discussion

Carbon dioxide absorption in EMISE was performed in a polypropylene hollow fiber membrane module in order to evaluate the process efficiency and

mass transfer behavior. The outlet concentration of carbon dioxide calculated as $C_{CO_2(g),out}/C_{CO_2(g),in}$ at pseudo-steady state, ranged between 0.65 and 0.7, which indicates a process efficiency of around 28–35% according to Eq. (7) for the studied experimental conditions.

Pseudo-steady state was obtained after about 1 h operating time for the studied range of carbon dioxide concentration (8 to 41% of $C_{CO_2(g),in}$). Fig. 2 shows an example of some experiments for different concentrations of CO_2 at the inlet of the contactor with a gas flow of $10 \text{ ml} \cdot \text{min}^{-1}$ and a liquid flow of $50 \text{ ml} \cdot \text{min}^{-1}$.

The absorption flux depends on the carbon concentration at the inlet of the contactor, as shown by Eq. (4). From Fig. 3 the overall mass transfer coefficient can be estimated from the Eq. (1) as the linear relationship between the absorption flux and the driving force in the hollow fiber module expressed as Δy_{lm} . This coefficient takes a value of $K_{overall} = (3.69 \pm 0.18) \times 10^7 \text{ m s}^{-1}$, in similarity to values reported in the literature where polypropylene hollow fiber module and Diethanolamine (DEA) solutions were studied [10].

According to Eq. (1), the overall mass transfer coefficient of the hollow fiber module is related to mass

transfer resistances in the gas, liquid and an additional resistance introduced by the membrane itself. To apply Eqs. (2) and (3), which allow the estimation of the individual mass transfer coefficients in the gas and liquid phases, parameters listed in Table 3 have been used.

The Henry's law constant is an estimated value taken from studies focused on CO_2 absorption using 1-ethyl-3-methylimidazolium-based ionic liquids [19,20]. Thus, the mass transfer coefficients in the gas phase, k_g and liquid phase, k_l , take a value of $6.22 \times 10^6 \text{ m} \cdot \text{s}^{-1}$ and $5.26 \times 10^{-6} \text{ m} \cdot \text{s}^{-1}$, respectively, according to Eqs. (2) and (3). By introducing k_g, k_l, H and experimental $K_{overall}$ in Eq. (1), assuming equilibrium conditions and $E = 1$ (no enhancement by chemical reaction) a mass transfer coefficient in the membrane is obtained ($k_m = 4.62 \times 10^{-7} \text{ m} \cdot \text{s}^{-1}$).

Hence the liquid phase and gas phases produce a resistance of 1.2% and 5.9% of the overall resistance. This involve that the polypropylene membrane produces the main resistance to mass transfer, taking a value of around 92.9% of the overall resistance.

If the membrane is the only resistance to mass transfer and considering that pores are filled with gas, the effective diffusion coefficient would be $D_{eff} = 4.94 \times 10^{-7} \text{ m}^2 \text{ s}^{-1}$, according to the expression:

$$D_{eff} = \frac{\epsilon \cdot D_{CO_2}}{\tau} \quad (8)$$

where D_{CO_2} is the diffusion coefficient of the gas, estimated according to Appendix A, and ϵ and τ are the porosity and tortuosity, respectively. Porosity of the membrane is 0.40 and tortuosity usually ranges between 2 and 6, averaging about 3. These values can be rationalized because solutes diffuse in three directions instead of one, so they diffuse about three times as far [18].

On the other hand, if the effective diffusion coefficient is calculated considering the experimental overall mass transfer coefficient, the next equation may be applied, since the membrane is the main resistance to mass transfer:

$$D_{eff} = k_m \cdot \delta = \left(K_{overall} \cdot \frac{d_0}{d_{lm}} \right) \cdot \delta \quad (9)$$

Table 3
Parameters used in Eqs. (1), (2) and (3)

$v_l, \text{m} \cdot \text{s}^{-1}$	9.53×10^{-3}
$v_g, \text{m} \cdot \text{s}^{-1}$	7.49×10^{-4}
$D_{l,CO_2}, \text{m}^2 \cdot \text{s}^{-1}$	3.02×10^{-10}
$D_{g,CO_2}, \text{m}^2 \cdot \text{s}^{-1}$	1.47×10^{-5}
$v, \text{m}^2 \cdot \text{s}^{-1}$	8.26×10^{-6}
$H, \text{dimensionless}$	0.122

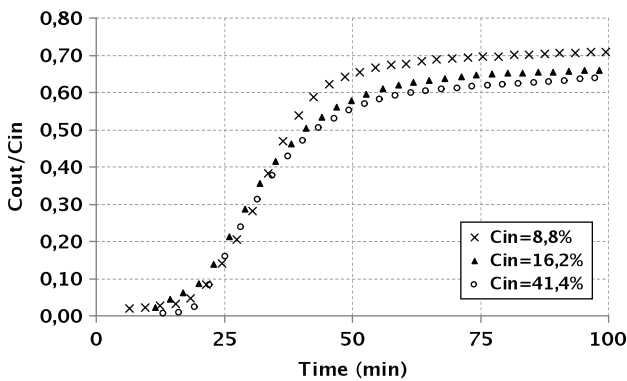

Fig. 2. CO_2 inlet concentrations versus experimental time.

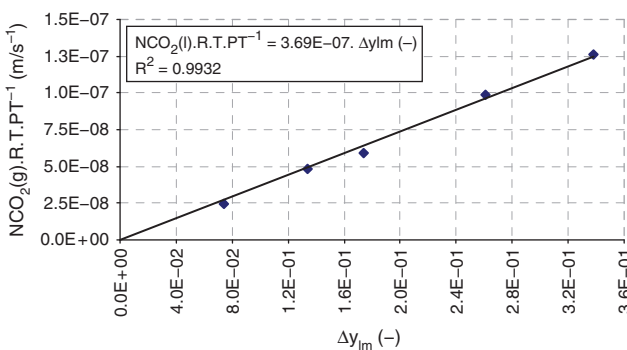

Fig. 3. Absorption flux versus carbon dioxide logarithmic mean molar fraction when EMISE is used as absorption liquid.

where d_o and d_{lm} are the outside and log mean diameters of the hollow fiber, and δ is the membrane thickness; a value of $D_{eff} = (1.72 \pm 0.18) \times 10^{-11} \text{ m}^2 \text{ s}^{-1}$ is obtained.

These differences between the theoretical D_{eff} and that obtained from experimental results could be associated with wetting of the membrane since the obtained value is in the typical range of diffusivity in a solid matrix with liquid occluded into pores (10^{-8} – $10^{-12} \text{ m}^2 \text{ s}^{-1}$) [21]. This effect of wetting would increase the resistance to mass transfer of the membrane significantly [22,25] but a deeper study is required to enforce this hypothesis.

Regarding SO_2 recovery, the mass transfer coefficient obtained in a previous work [2] took a value of $K_{overall} = (3.38 \pm 0.09) \times 10^{-6} \text{ m s}^{-1}$. The overall mass transfer coefficient result 9.16 times higher than that obtained in CO_2 system. The ceramic membrane was the main resistance to mass transfer, but results lower than the overall resistance obtained when polypropylene membrane is used, because in spite of the higher thickness only 4% wetting was obtained. This is an interesting difference to consider because ceramic membranes could become a strong competitor of polymeric membranes, also because of their chemical and thermal resistance. Further research will be focused on the use of ceramic contactor for CO_2 recovery.

5. Conclusion

The evaluation of carbon dioxide absorption using a polypropylene hollow fibre contactor and the ionic liquid 1-ethyl-3-methylimidazolium ethylsulfate as absorption liquid has been experimentally verified. About 1 h is needed to achieve a pseudo-steady-state. Results show that around 28–35% of carbon dioxide can be recovered under experimental conditions studied and an overall mass transfer coefficient of $K_{overall} = (3.69 \pm 0.18) \times 10^{-7} \text{ m} \cdot \text{s}^{-1}$ has been obtained. Mass transfer coefficient in the gas, k_g and liquid phase, k_l take a value of $6.76 \times 10^{-6} \text{ m} \cdot \text{s}^{-1}$ and $5.26 \times 10^{-6} \text{ m} \cdot \text{s}^{-1}$, respectively, and membrane mass transfer coefficient results $k_m = 4.58 \times 10^{-7} \text{ m} \cdot \text{s}^{-1}$. Thus, the polypropylene membrane produces the main resistance to mass transfer with 92.9% of influence on the overall resistance. An effective diffusivity of $D_{eff} = (1.72 \pm 0.18) \times 10^{-11} \text{ m}^2 \text{ s}^{-1}$ is obtained in CO_2 system, which is in the typical range of values obtained when a liquid is occluded in a solid matrix.

Mass transfer coefficients in a polymeric and ceramic membrane have been compared. Polymeric membranes are of great interest for this application because of hydrophobic character, commercial availability and price. However, in this work a lower overall mass transfer coefficient value has been reported compared to that obtained in a previous work for a ceramic membrane [2].

Furthermore chemical resistance of polymeric materials is limited, contrasting with the high chemical and thermal resistance of ceramic membranes.

Acknowledgement

This research has been funded by the Spanish Ministry of Science and Technology (Project CTM2006-00317 and Project EUI2008-03857).

Appendix A. Diffusivity

Since pore diameter, d_p , in the membrane is $4 \times 10^{-8} \text{ m}$; membrane diffusion coefficient is a combination of bulk and Knudsen diffusion coefficients [26].

$$\frac{1}{D_{\text{CO}_2}} = \frac{1}{D_{\text{CO}_2,b}} + \frac{1}{D_{Kn}} \quad (10)$$

The molecular diffusion coefficient in the gas phase can be calculated by the Fuller equation according to [21]:

$$D_{\text{CO}_2,b} = \frac{0.01013 \cdot T^{1.75} \cdot \left(\frac{1}{M_A} + \frac{1}{M_B} \right)^{0.5}}{P \cdot \left[(\Sigma v_A)^{1/3} + (\Sigma v_B)^{1/3} \right]^2} \quad (11)$$

Units of T and P are K and Pa, respectively. M_A and M_B are molecular weights in $\text{g} \cdot \text{mol}^{-1}$. Σv is the summation of atomic diffusion volumes, and for air and carbon dioxide take a value of 20.1 and 26.9, respectively. The Knudsen diffusion coefficient can be determined as [21,27]:

$$D_{Kn} = \frac{1}{3} d_p \sqrt{\frac{8RT}{\pi M}} \quad (12)$$

where d_p is the pore diameter (m), R is the gas constant ($\text{J} \cdot \text{kmol}^{-1} \cdot \text{K}^{-1}$), T is the temperature and M is the molecular weight ($\text{Kg} \cdot \text{kmol}^{-1}$).

References

- [1] A. Stankiewicz and T. Van Gerven, Structure, Energy, Synergy, Time The fundamentals of Process Intensification. Ind. Eng. Chem. Res., 48 (2009) 2465–2474.
- [2] P. Luis, A. Garea and J. Irabien, Zero solvent emission process for sulfur dioxide recovery using a membrane contactor and ionic liquids. J. Membrane Sci., 330 (2009) 80–89.
- [3] P. Luis, A. Garea and A. Irabien, Sulfur Dioxide Non-dispersive absorption in *N,N*-dimethylaniline using ceramic membrane contactor, J. Chem. Technol. Biot., 83 (2008) 1570–1577.
- [4] K. Simons, K. Nijmeijer and M. Wessling, Gas–liquid membrane contactors for CO_2 removal. J. Membrane Sci., 340(12) (2009) 214–220.

- [5] D. Wappel, G. Gronald, R. Kalb and J. Draxler, Ionic liquids for post-combustion CO₂ absorption 2009. *International J. Grenhouse gas control*, 4(3) (2010) 486–494.
- [6] P. Luis, C.A.M. Afonso, I.M. Coelho, J. Crespo and A. Irabien, Ionic liquids as efficient solvents for sulfur dioxide recovery. 23rd European Symposium on Applied Thermodynamics (ESAT), Cannes (France), 29 May–1 June 2008.
- [7] Z. Qi and E.L. Cussler, Microporous hollow fibers for gas absorption, part II; mass transfer across the membrane. *J. Membrane Sci.*, 23 (1985) 321–332.
- [8] Y. Lee, R.D. Noble, B.-Y. Yeom, Y.-I. Park and K.-H. Lee, Analysis of CO₂ removal by hollow fiber membrane contactors. *J. Membrane Sci.*, 194(1) (2001) 57–67.
- [9] D. Montigny, P. Tontiwachwuthikul and A. Chakma, Using polypropylene and polytetrafluoroethylene membranes in a membrane contactor for CO₂ absorption. *J. Membrane Sci.*, 277(1&2) (2006) 99–107.
- [10] W. Rongwong, R. Jiratananon and S. Atchariyawut, Experimental study on membrane wetting in gas-liquid membrane contacting process for CO₂ absorption by single and mixed absorbents. *Sep. Purif. Technol.*, 69 (2009), 118–125.
- [11] V.Y. Dindore, D.W.F. Brilman, P.H.M. Feron, Versteeg G.F. CO₂ absorption at elevated pressures using a hollow fiber membrane contactor. *J. Membrane Sci.*, 235(12) (2004) 99–109.
- [12] H.A. Rangwala, Absorption of carbon dioxide into aqueous solutions using hollow fiber membrane contactors, *J. Membrane Sci.*, 112(2) (1996) 229–240.
- [13] A. Gabelman, S.T. Hwang, Hollow fiber membrane contactors. *J. Membrane Sci.*, 159(1&2) (1999) 61–106.
- [14] S. Atchariyawut, C. Feng, R. Wang, R. Jiratananon and D.T. Liang, Effect of membrane structure on mass-transfer in the membrane gas-liquid contacting process using microporous PVDF hollow fibers. *J. Membrane Sci.*, 285(1–2), (2006) 272–281.
- [15] H. Kreulen, C.A. Smolders, G.F. Versteeg and W.P.M. Van Swaaij, Determination of mass transfer rates in wetted and non-wetted microporous membranes. *Chem. Eng. Sci.*, 48(11) (1993) 2093–2102.
- [16] M.H. El-Naas, M. Al-Marzougi, S.A. Marzouk and N. Abdullatif, Evaluation of the removal of CO₂ using membrane contactors: Membrane wettability. *J. Membrane Sci.*, 350(1&2) (2010) 410–416.
- [17] W. Zhang, G. Chen, W. Sun and J. Li, Effect of membrane structural characteristics on mass transfer in a membrane absorption process. *Separat. Sci. Technol.*, 45(9) (2010) 1216–1227.
- [18] E.L. Cussler, *Diffusion. Mass Transfer in Fluid Systems*, 2nd ed. Cambridge University Press, New York (1997).
- [19] A. Finotello, J.E. Bara, D. Camper and R.D. Noble, Room-Temperature Ionic Liquids: Temperature Dependence of Gas Solubility Selectivity. *Ind. Eng. Chem. Res.*, 47 (2008) 3453–3459.
- [20] A. Yokozeki, M.B. Shiflett, C.P. Junk, L.M. Grieco and T. Foo, Physical and Chemical Absorptions of Carbon Dioxide in Room-Temperature Ionic Liquids. *J. Physic Chemistry*, 112B (2008) 16654–16663.
- [21] R.H. Perry and D.W. Green, *Perry's Chemical Engineers' Handbook*, 7th ed., McGraw-Hill, New York (1997).
- [22] M. Mavroudi, S.P. Kaldis and G.P. Sakellariopoulos, A study of mass transfer resistance in membrane gas-liquid contacting processes. *J. Membrane Sci.*, 272 (2006) 103–115.
- [23] A. Malek, K. Li and W.K. Teo, Modeling of microporous hollow fiber membrane modules operated under partially wetted conditions. *Ind. Eng. Chem. Res.*, 36 (1997) 784–793.
- [24] R. Wang, H.Y. Zhang, P.H.M. Feron, and D.T. Liang, Influence of membrane wetting on CO₂ capture in microporous hollow fibre membrane contactors. *Sep. Purif. Technol.*, 46 (2005) 33–40.
- [25] J. Lu, Y.F. Zheng and M.D. Cheng, Wetting mechanism in mass transfer process of hydrophobic membrane gas absorption. *J. Membrane Sci.*, 308 (2008) 180–190.
- [26] J.L. Li and B.H. Chen, Review of CO₂ absorption using chemical solvents in hollow fiber membrane contactors. *Sep. Purif. Technol.*, 41 (2005) 109–122.
- [27] M. Mavroudi, S.P. Kaldis and G.P. Sakellariopoulos, Reduction of CO₂ emissions by a membrane contacting process. *Fuel*, 82 (15–17) (2003) 2153–2159.