

A Resilience-based Architecture for Joint Distributed Energy Resources Allocation and Hourly Network Reconfiguration

Ehsan Kianmehr, Saman Nikkhah, Vahid Vahidinasab, *Senior Member, IEEE*, Damian Giaouris, and Phil Taylor, *Senior Member, IEEE*

Abstract— As a result of the recent innovations in deployment of plug-in electric vehicles (PEVs), this technology can play an important role as a distributed energy resource (DER) in supplying the system demand of the power systems of the future. This paper, introduces a methodology for optimal coordinated allocation of wind farms (WFs), energy storage systems (ESSs) and PEV's parking lots (PEV-PLs) considering demand response programs (DRPs) and hourly distribution network reconfiguration (DNR) in normal and severe contingency conditions. In the proposed methodology, participation of different types of loads is also examined. The objective function is to minimize the total costs of purchased power from upstream network and WFs, along with the costs of commercial/industrial loads flexibility and residential loads curtailment. To validate the performance of proposed methodology, it is implemented on the well-known IEEE 33-bus distribution test system. The simulation results, validate the feasibility and effectiveness of the proposed approach.

Index Terms— Allocation of DERs, storage systems, network reconfiguration, resilience, wind farms, plug-in electrical vehicle, parking lots, demand response programs.

I. NOMENCLATURE

Indices:

ij	Branch between the buses i^{th} and j^{th}
i, j	Index of buses
t	Time interval [hour]

Sets:

$\Gamma_{b/l}$	All system buses/ lines
$\Gamma_{r/c/d}$	Residential/commercial/industrial load buses
Γ_{sub}	Substation connecting the network to main grid
Γ_t	Time intervals
$\Gamma_{WF/ESS/PEV}$	Wind farms/ Energy storage systems/ PEV-PLs

Parameters:

$C_p^{sub/WF}$	Cost of active power procurement from main grid/WFs (\$/MWh)
----------------	--

$C_p^{cur/flex}$	Cost of load curtailment/flexibility (\$/MWh)
$CF_{i,t}^{WF}$	Coefficient for expected power output from WF installed at bus i on hour t .
G_{ij} / B_{ij}	Conductance and Susceptance of element ij^{th} of the YBUS matrix
$N_{max}^{WF/ESS/PEV}$	Maximum number of WFs/ESS/PEV-PLs
NM_{max}^{PEV}	Maximum number of PEVs
$PD_{i,t}^{r/c/d}$	Active power demand of residential/commercial/industrial loads (MW)
$P_{i,t}^{c,max} / P_{i,t}^{d,max}$	Maximum charging/discharging power of ESS
$P_i^{WF,max/min}$	Maximum/minimum wind power generation (MW)
$(P/Q)_{sub}^{max/min}$	Maximum/minimum active/reactive power of substation (MW/MVar)
$P_i^{c,max} / P_i^{d,max}$	Maximum charging/discharging power of PEV
$QD_{i,t}^{r/c/d}$	Reactive power demand of residential/commercial/industrial loads (MVar)
$\eta_{i,t}^{(c/d)_{ESS/PEV}}$	Charging/discharging efficiencies of ESS/PEV's battery at bus i on time t
$ \Gamma_{(l,t)} $	Number of lines/ time intervals
$\gamma_{max}^{c/i}$	Maximum flexibility of commercial/industrial loads
Variables:	
$Cap_{i,t}^{PEV,max}$	Maximum capacity of i^{th} PL at time t
$E_{i,t}^{PEV}$	Energy stores at PEV (MWh)
$I_{R/M_{ij}}$	Real/imaginary part of current flow
$L_i^{WF/ESS/PEV}$	Binary variable of the location of WFs/ESSs/PEV-PLs (1 = installed, 0 = otherwise)
$N_{i,t}^{PEV}$	Integer variable for modelling the number of PEVs of i^{th} PL at time t
$P_{i,t}^{Sub} / Q_{i,t}^{Sub}$	Active/reactive power of substation (MW/MVar)
$PD_{i,t} / QD_{i,t}$	Active/reactive power demand (MW/MVar)
$P_{i,t}^{cur} / Q_{i,t}^{cur}$	Curtailed active/reactive demand (MW/MVar)
$P_{i,t}^{c,ESS} / P_{i,t}^{d,ESS}$	ESS charging/discharging power (MW)
$PD_{i,t}^{cf} / QD_{i,t}^{df}$	Flexible active power of commercial/industrial loads (MW)
$P_{i,t}^{WF} / Q_{i,t}^{WF}$	Injected active/reactive power of WFs (MW/MVar)
$P_{i,t}^{c,PEV} / P_{i,t}^{d,PEV}$	PEV charging/discharging power (MW)
$QD_{i,t}^{cf} / QD_{i,t}^{df}$	Flexible reactive power of commercial/industrial loads (MVar)

Manuscript received June 5, 2018; accepted February 10, 2019. This work is carried out as part of the InteGRIDy project. InteGRIDy project is being financed by the European Commission under Grant agreement 731268. Paper no. TII-18-1455. (Corresponding author: Vahid Vahidinasab.)

Ehsan Kianmehr is with the Department of Electrical Engineering, Doroud Branch, Islamic Azad University, Doroud, Iran (email: Ehsan.Kianmehr@iau-doroud.ac.ir).

Saman Nikkhah is with the Department of Electrical Engineering, University of Zanjan, Zanjan, Iran (email: s.nikkhah@znu.ac.ir).

Vahid Vahidinasab is with the department of Electrical Engineering, Abbaspour School of Engineering, Shahid Beheshti University, Tehran, Iran and the School of Engineering, Newcastle University, Newcastle upon Tyne, UK (email: v_vahidinasab@sbu.ac.ir, vahid.vahidinasab@newcastle.ac.uk).

Damian Giaouris and Phil Taylor are with the School of Engineering, Newcastle University, Newcastle upon Tyne, UK (email: damian.giaouris@newcastle.ac.uk, phil.taylor@newcastle.ac.uk).

$SOC_{i,t}^{ESS}$	State of charge of ESS (MWh)
$V_{i,t}$	Voltage magnitude of bus i at time t
$\gamma_{i,t}^{flex}$	Load flexibility variable
$\theta_{ij,t}$	Voltage angle difference between nodes i and j at time t
$\mathcal{G}_{ij,t}$	Binary variable for the line between buses i and j ($1 =$ connected, $0 =$ disconnected)

Functions:

$\pi_{sub/WF}$	Cost of purchasing power from main grid/ WFs
$\pi_{Lsh/flex}$	Cost of load curtailment/flexibility

Abbreviations:

DER	Distributed energy resource
DG	Distributed generation
DRP	Demand response program
DFIG	Doubly fed induction generator
DNR	Distribution network reconfiguration
DV	Dependent variables
ESS	Energy storage system
GAMS	General Algebraic Modeling System
HNR	Hourly network reconfiguration
HDNR	Hourly distribution network reconfiguration
IDV	Independent decision variables
MINLP	Mixed-integer non-linear programming
PV	Photovoltaic
PEV	Plug-in electric vehicle
PEV-PL	Plug-in electric vehicle parking lot
SOC	State of charge
SOH	State of health
V2G	Vehicle to grid
V4G	Vehicle for grid
WF	Wind farm
WT	Wind turbine

II. INTRODUCTION

THANKS to the recent innovations in modernization of power system, distributed energy resources (DERs) are now crucial in supplying the system demand in different conditions. In this regard, in addition to conventional DERs such as wind turbines (WTs), photovoltaic (PV) systems, diesel generators, and energy storage systems (ESSs), an alternative option is introduced as the DER for improved operation of smart grid technologies. This alternative option is transportation electrification with the concept of plug-in electric vehicles (PEVs).

Due to the potential of PEV's parking lots (PEV-PLs) to exchange energy with electric power system, they can be considered as the DER. Therefore, in the near future, PEVs can play a significant role in supplying system loads. Although, the PEVs consume electric power and act as a consumer, deployment of vehicle to grid (V2G) technologies allows the PEVs to exchange energy with power grid. In such circumstances, PEV's owners can play their own role in power system and gain from participation in the V2G services and in parallel through involvement in the provision of grid services, play an important role as a grid facility which can be called vehicle for grid (V4G). All of the abovementioned technologies, are important cross-functional solutions that

accelerate the integration of DERs and help the network operator in optimizing grid operation.

In addition to the DERs, there are more attractive and affordable alternatives which make today's power systems smarter than traditional networks. One of these alternatives is the distribution network reconfiguration (DNR). Although the concept of DNR was introduced several years ago, this methodology is now taken into consideration as a flexibility solution in modernization of the power systems [1]. The DNR is defined as the process of changing the status of normally open/closed switches of distribution network to reach a configuration that optimizes desired objectives while satisfying all operational planning constraints of network without isolating any network node(s) [2].

In addition to the role of these technologies in normal network operation, they provide more flexibility for power utility in the severe contingency conditions in which power lines are damaged, or connection with the upstream network is disrupted. This problem has forced network operators to make a pervasive plan for the resilient operation of the system in severe contingency conditions such as technical problems, natural disasters, and man-made problems which cause irrecoverable losses. Therefore, occurrence of severe contingency condition is really a prominent problem and consequently, development of an appropriate strategy to decrease the negative impacts of this issue on the network have become necessary.

Up to now, various research works have been published in the context of the smart grid operation in both normal and contingency conditions. In this study, the literature has been classified according to the types of the components as: a) PEV-PLs, b) distributed generation (DG) and ESS, c) DNR, and d) demand response program (DRP).

a) PEV-PLs: In spite of their challenges, PEVs have remarkable economic, social, and operational advantages for the networks. Consequently, many research works have been published to investigate the different aspects of PEVs in power grid. A multi-objective optimization model is proposed by El-Zonkoly *et al.* in [3] for optimal allocation of PLs within the distribution network using artificial bee colony optimization algorithm. In [4], the renewable energy sources and PEV-PLs are simultaneously allocated in the network using a two-level optimization approach in which the mutual behavior of PEV-PLs and renewable-based DGs is investigated. A robust management model has been proposed by [5] for optimal scheduling of the electric vehicles active and reactive power, considering different uncertainties. Since the robust optimization is a bi-level technique, authors have used the Benders decomposition to reduce the processing time. A remarkable techno-economic planning model was proposed in [6] for long-term planning of PEV-PLs from parking lot owners' perspective. The work presented considers a coordinated charging scheme which shifts the energy consumption from on-peak to off-peak periods. Effect of different DRPs (e.g. real-time pricing, time-of-use) on the real-time operation of PEVs has been investigated in [7]. The PEVs have been considered as the end-user and their participation in the incentive/price-based DRPs have been

investigated. Bidirectional PEVs, which have numerous advantages compared to unidirectional, have been used in [8] for management of a smart distribution network and compensation of the harmonics raised by nonlinear loads. In [9], a methodology is proposed which uses the fuel of PEVs as a source of power for the residential loads when the link of such loads with upstream grid is disrupted.

b) DG and ESS: Due to the key role of DGs and ESSs in supplying system loads in nowadays' power system, several studies have been published for allocating such DERs in network, in different conditions. The reference [10] proposes a seasonal planning procedure for optimal siting and sizing of the storage units and optimal network reconfiguration. Also, in [11], a planning schedule is proposed for ESSs with incorporation of DGs and DNR. In this study, authors focused on coordination of power electronic devices such as smart inverters with ESSs to decrease the investment costs of ESSs. In [12], a voltage stability constrained model is proposed for optimal wind farm (WF) allocation in a long-term planning horizon. Awad *et al.* [13] proposed a long-term model for planning of ESSs with the aim of profit maximization of distributed ESSs. The authors considered the load curtailment to prevent complete blackout during planning horizon in a contingency condition. A probabilistic approach for optimal allocation of DGs is introduced in [14] considering the uncertainty of system demand. An economical model is proposed in [15] for allocation of ESS in the presence of volatile wind power generation. The authors used the five point estimate method to model the uncertainty of wind energy which has considerable drawbacks in modeling uncertainty in comparison with information gap decision theory [16].

c) DNR: Recently, numerous research works have been published for the problem of DNR. Generally, authors of these papers have employed different methodologies and techniques to solve the problem of DNR. Arasteh *et al.* [17] proposed a planning model which coordinates the DNR and active distribution network expansion planning which considers DRPs as the virtual distributed resources. In [18], a fast, non-dominated sorting genetic algorithm has been proposed to the problem of DNR. The results obtained by [19] demonstrate the robustness of proposed adaptive particle swarm optimization in comparison with other techniques like genetic algorithm which is employed by Asraei *et al.* [20] for the reconfiguration of the network in the presence of DGs. The concept of DNR is coordinated with microgrid formation in [21], to restore the system loads after natural disaster. Lin *et al.* [22] combined hardening and operational measures as a main aspect of power system resilience using a tri-level defender-attacker-defender model. The authors performed the reconfiguration and microgrid islanding schemes as a third level, which is defender plan, to measure the operation of grid from system operator perspective.

d) DRP: In smart grids, customers can play their own role to improve the characteristics of networks [23]. A planning model is proposed in [24] for expansion of distribution systems in the presence of DRPs and DERs. In [25], participation of customers in increasing the resilience of microgrid is investigated. To do so, four security indices have been introduced by authors to measure the resilience of power system after weather events. An emergency DRP is proposed

by [26] so as to investigated the role of end-users in contingency condition in case of generation failure. Taxonomy of aforementioned research works is given in Table 1. According to this table, some important points have been ignored in previous research works. For instance, although DGs are considered in [3], they have not been optimally allocated within the network. Besides, while DNR is employed in [5], the hourly changes of the network switches have not been taken into consideration.

Although a careful planning model is necessary for optimal operation of network in severe contingency conditions, to the best of the authors' knowledge, there are no research works which have simultaneously considered the important components of smart grid such as DGs, ESSs, PEV-PLs, demand response (DR) and optimal switching of network to increase the resilience of grid in such a situation. Moreover, in the papers which have focused on optimal allocation of DERs, there is not an appropriate model for selecting all system buses as candidate nodes for DERs installation. Likewise, there are no publications which have focused on coordination of the role of PEVs and hourly network reconfiguration in decreasing load curtailment. In this regard, this paper proposes a methodology to decrease the load shedding in normal and contingency conditions. The introduced model is a comprehensive methodology which considers the PEV-PLs, WFs, and ESSs as a DERs, and obtains optimal hourly configuration for the network, and additionally, DRP is taken into consideration using the concept of load shedding for the residential and load flexibility for the commercial and industrial loads. The objective function of the problem is minimizing the costs of load curtailment and flexibility, and costs of purchasing power from substation and WFs.

The literature review, has highlighted several important deficiencies which are as follows:

- (i) A wide majority of papers which have focused on network reconfiguration, have not solved the problem on an hourly basis.
- (ii) The proposed allocation methodologies in the previous literature have considered a small fraction of system buses for finding optimal location and the size of DERs and have not examined the important factors in planning and operation sectors.
- (iii) The role of customers and PEVs have not been investigated in resilient operation of the power systems.
- (iv) The interconnection between DNR and co-operation of different DERs in normal/contingent condition has not been effectively demonstrated.

In brief, to the best of the authors' knowledge, this paper contributes to the state of the art with the following key contributions:

- A new model has been proposed for DNR in which the on/off status of the network switches is optimized on an hourly basis.
- A resilience-oriented allocation scheme is proposed for PEV-PLs, ensuring resilient operation of the network after/before occurrence of any faults in the system.
- A comprehensive co-operation model is proposed which simultaneously defines the optimal location and size of

WFs, PEV-PLs, ESSs, and optimal hourly configuration of the network.

- The key role of different load types is demonstrated in the model to show the importance of customers' participation in contingency conditions.
- All system buses are considered as the candidate buses for installing different DERs with regard to both the physical and operational constraints of the system.

The rest of this paper is organized as follows. In Section 2, the problem under study is described. The mathematical formulation is presented and discussed in Section 3. The case study is provided in Section 4. Section 5 presents the numerical result. Finally, Section 6 concludes the paper.

III. FRAMEWORK DESCRIPTION

Due to the techno economic problems of the expansion of existing distribution systems, DERs could be an effective solution for delivery of power to customers with minimum active power losses and load curtailment. Even though the distributed systems have a mesh structure, they operate in radial operation (e.g. easy protection and short circuit current limiting). Regarding this, DSOs try to find an optimal radial configuration for the network that the loads of the system are supplied through existing energy resources, and various operational, economic, and security constraints are satisfied. However, conventional DNR models fail to adapt to the constraints and opportunities presented by new network technologies. Consequently, an hourly DNR (HDNR) is an absolutely necessary consideration for today's systems.

In view of the above, adaptation of a comprehensive co-operation model in which, an optimal operation model for DERs along with HDNR, which is more likely to result in resilient operation of the network, is vital. The aim of this study is to simultaneously define the optimal location and size of PEV-PLs, ESSs, and WFs considering the optimal HDNR

for radial distribution systems to achieve several benefits, especially resilient operation of the network in different conditions. It is to be noted that the co-operation of ESSs and PEV-PLs allows the DSO to benefit from penetration of WFs, and prevent possible operational problems due to the high penetration of wind energy. Besides, it investigates the role of customers in providing the resilient operation in such modernized radial grid, using the concepts of load curtailment and flexibility. The main goal is to decrease the load shedding of residential loads, especially in severe contingency conditions with consideration of different operational costs. In this methodology, operation of distribution system for normal and contingency conditions is examined. To do so, at first, some of distribution lines including the power line which connects the distribution system to the upstream network are selected as the candidate lines which are disrupted in a specific time because of weather events or man-made attacks. It is worth mentioning that the selected lines experience the connected and disconnected status which cause normal and contingency conditions in the system, during the operation horizon. Then, optimal location and size of PEV-PLs, ESSs, and WFs, simultaneously obtained with optimal hourly on/off status of distribution system switches, amount of the load that should be curtailed or degree of flexibility of commercial and industrial loads of the network, to decrease the different cost components of the system which include cost of load curtailment. The proposed framework, and the explained stages are depicted in Fig. 1.

IV. PROBLEM FORMULATION

This section presents the general formulation addressed in this paper. At the following subsections, the different components of the model are expressed.

A. Objective function

As it was mentioned, this work aims to minimize an objective

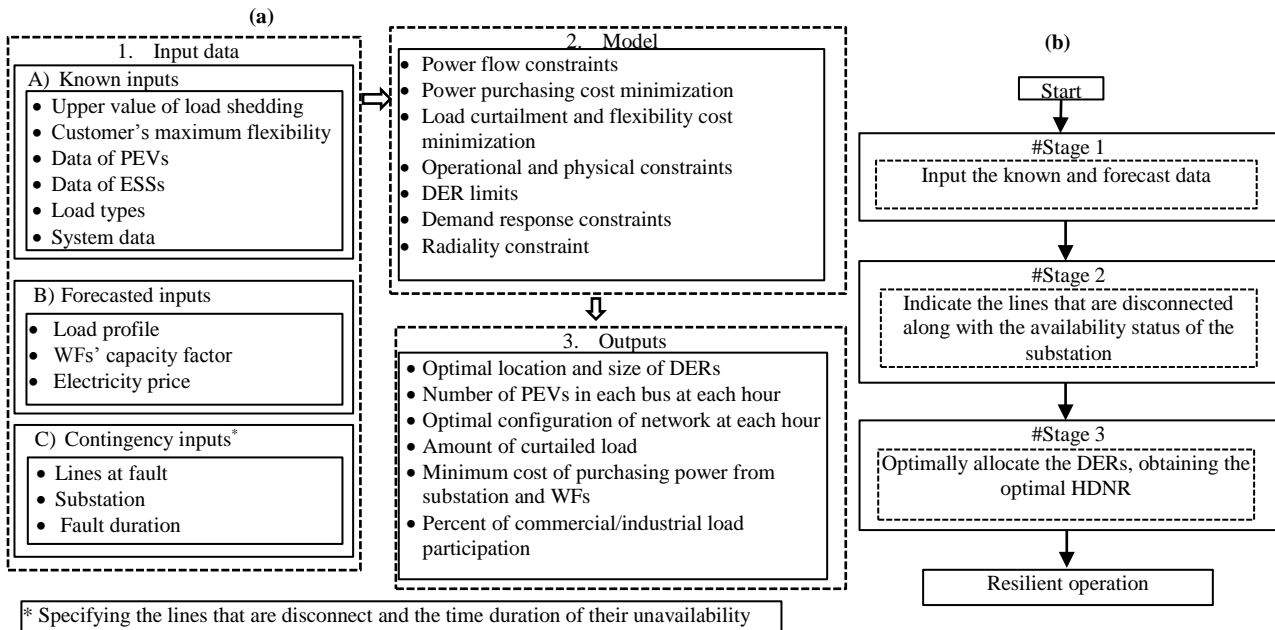

Fig. 1. (a) Proposed framework of the proposed co-operation problem, (b) The stages of optimal DERs allocation and HDNR in both normal and contingency condition.

TABLE I
TAXONOMY OF RESEARCH WORKS ON OPTIMAL ALLOCATION OF DERS AND DNR.

Reference Number	HDNR	DERs CONSIDERATION			DERs Allocation			DR	Contingency
		DG	ESS	PEV	DG	ESS	PEV		
[2]	No	No	No	No	No	No	No	No	
[3]	No	Yes	No	Yes	No	No	Yes	No	
[4]	No	Yes	No	Yes	No	No	Yes	No	
[5]	No	No	No	Yes	No	No	Yes	Yes	
[6]	No	Yes	No	Yes	No	No	Yes	No	
[7]	No	Yes	No	Yes	Yes	No	Yes	No	
[8]	No	No	No	Yes	No	No	Yes	No	
[9]	No	Yes	Yes	Yes	No	No	No	Yes	
[10]	Yes	Yes	Yes	No	No	Yes	No	No	
[11]	Yes	Yes	Yes	No	No	Yes	No	No	
[12]	No	Yes	No	No	Yes	No	No	No	
[13]	No	No	Yes	No	No	Yes	No	No	
[14]	No	Yes	No	No	Yes	No	No	No	
[15]	No	Yes	Yes	No	No	Yes	No	No	
[16]	No	No	No	No	No	No	No	No	
[17]	No	No	No	No	No	No	No	No	
[18]	No	No	No	No	No	No	No	No	
[19]	No	No	No	No	No	No	No	Yes	
[20]	No	No	No	No	No	No	No	No	
[21]	No	No	No	No	No	No	No	No	
[22]	No	No	No	No	No	No	No	Yes	
[23]	No	Yes	No	No	No	No	No	Yes	
[24]	No	Yes	Yes	No	No	No	No	Yes	
[25]	No	Yes	Yes	No	No	No	No	Yes	
[26]	No	No	No	No	No	No	No	Yes	
This Paper	Yes	Yes	Yes	Yes	Yes	Yes	Yes	Yes	Yes

function which consists of the costs of purchased power from upstream substation and WFs, load curtailment, as well as the cost that should be paid to the commercial and industrial customers for decreasing their consumption, as follows:

$$\text{Minimize } \pi_{sub} + \pi_{WF} + \pi_{Lsh} + \pi_{Lflex} \quad (1)$$

$$\pi_{sub} = \sum_{i \in \Gamma_{sub}} \sum_{t \in \Gamma_t} P_{i,t}^{sub} \times C_p^{sub} \quad (2)$$

$$\pi_{WF} = \sum_{i \in \Gamma_{WF}} \sum_{t \in \Gamma_t} P_{i,t}^{WF} \times C_p^{WF} \quad (3)$$

$$\pi_{Lsh} = \sum_{i \in \Gamma_n} \sum_{t \in \Gamma_t} P_{i,t}^{cur} \times C_p^{cur} \quad (4)$$

$$\pi_{Lflex} = \sum_{i \in \Gamma_{ci}} \sum_{t \in \Gamma_t} (PD_{i,t}^c + PD_{i,t}^d) \times C_p^{flex} \times \gamma_{i,t}^{flex} \quad (5)$$

This objective function is subjected to the different equality and inequality constraints expressed in the next subsections.

B. Active and reactive power balance

To find an optimal schedule of DERs, operation and switching states of network, amount of curtailed load, and load participation in flexibility provision, the load flow equations must be considered. The following load flow constraints including the injected power from substation and WFs, ESSs and PEVs charging and discharging, net power of the loads from residential, commercial and industrial customers, and the network's flows considered at each of the distributed system buses ($\forall i, j \in \Gamma_b, t \in \Gamma_t, \vartheta_{ij} \in \{0,1\}$):

$$P_{i,t}^{sub} + P_{i,t}^{WF} + (P_{i,t}^{C_{ESS}} - P_{i,t}^{D_{ESS}}) + N_{i,t}^{PEV} (P_{i,t}^{C_{PEV}} - P_{i,t}^{D_{PEV}}) - PD_{i,t} + P_{i,t}^{cur} = \sum_j (\vartheta_{ij,t} \times P_{ij,t}) \quad (6)$$

$$Q_{i,t}^{sub} + Q_{i,t}^{WF} - QD_{i,t} + Q_{i,t}^{cur} = \sum_j (\vartheta_{ij,t} \times Q_{ij,t}) \quad (7)$$

$$P_{ij,t} = V_{i,t}^2 G_{ij} - V_{i,t} V_{j,t} (G_{ij} \cos \theta_{ij,t} + B_{ij} \sin \theta_{ij,t}) \quad (8)$$

$$Q_{ij,t} = -V_{i,t}^2 G_{ij} - V_{i,t} V_{j,t} (G_{ij} \sin \theta_{ij,t} - B_{ij} \cos \theta_{ij,t}) \quad (9)$$

$$PD_{i,t} = PD_{i,t}^r + PD_{i,t}^{ef} + PD_{i,t}^{df} \quad (10)$$

$$QD_{i,t} = QD_{i,t}^r + QD_{i,t}^{ef} + QD_{i,t}^{df} \quad (11)$$

Moreover, $P_{i,t}^{sub}$ and $P_{i,t}^{sub}$ are nonzero variables stands for the substation bus:

$$\begin{cases} P_{sub}^{\min} \leq P_{i,t}^{sub} \leq P_{sub}^{\max} & ; \forall i \in \Gamma_{sub} \\ 0 & ; \text{otherwise} \end{cases} \quad (12)$$

$$\begin{cases} Q_{sub}^{\min} \leq Q_{i,t}^{sub} \leq Q_{sub}^{\max} & ; \forall i \in \Gamma_{sub} \\ 0 & ; \text{otherwise} \end{cases} \quad (13)$$

C. Radiality constraints

In distribution networks, in order to have a radial configuration, the network should have a tree-like topology in where each load is linked through a unique path to the substation/DERs [1]. The next circumstance is satisfied via the load flow equations in which all of the system loads are fed by the substation/ DERs and there is no mesh (loop) in the network. For the first condition satisfaction, in each hour, the configuration of network will be radial when the total number of the closed switches be equal to the number of the nodes minus one. Also, the status of $\vartheta_{ij,t}$ and $\vartheta_{ji,t}$ should be the same. It is worth mentioning that in this study, the aforementioned radiality conditions should be satisfied each hour. The mentioned radiality constraints are modeled as:

$$\sum_{i,j \in \Gamma_b} \vartheta_{ij,t} = 2(|\Gamma_t| - 1) \quad (14)$$

$$\vartheta_{ij,t} = \vartheta_{ji,t}, \quad \forall i, j \in \Gamma_b, t \in \Gamma_t \quad (15)$$

where $\vartheta_{ij,t}$ identifies the status of branch between i^{th} and j^{th} buses. For the mentioned decision variable, $\vartheta_{ij,t} = 1$ shows

the closed status of the switch and $\vartheta_{ij,t} = 0$ illustrates the opened status of the switch.

D. Operational limits

The following represent the operational constraints of network including the voltage profile, capacity of distribution lines, and injected power from upstream network, which should be limited within permissible values as follows ($\forall i, j \in \Gamma_b, t \in \Gamma_t, \vartheta_{ij} \in \{0,1\}$).

$$V_i^{\min} \leq V_{i,t} \leq V_i^{\max} \quad (16)$$

$$\vartheta_{ij,t} (I_{R_{ij,t}}^2 + I_{M_{ij,t}}^2) \leq I_{MAX_{ij}}^2 \quad (17)$$

$$I_{R_{ij,t}} = G_{ij} (V_{i,t} \cos \theta_{i,t} - V_{j,t} \cos \theta_{j,t}) - B_{ij} (V_{j,t} \sin \theta_{i,t} - V_{j,t} \sin \theta_{j,t}) \quad (18)$$

$$I_{M_{ij,t}} = G_{ij} (V_{i,t} \sin \theta_{i,t} - V_{j,t} \sin \theta_{j,t}) + B_{ij} (V_{j,t} \cos \theta_{i,t} - V_{j,t} \cos \theta_{j,t}) \quad (19)$$

E. DRPs

In the contingency condition, participation of costumers in management of system is a decisive factor which can prevent the system from complete blackout. This participation which is known as DR is divided into different categories. The DR which is called here as DRPs, including direct load control, or interruptible services can be used as additional reserves during contingency conditions. In this study, two different DRPs are considered taking into account the load curtailment with an associated cost for the residential customers, as well as allocating special payments for the flexibility of commercial and industrial customers. In this method, the residential customers curtail their loads with significant high cost; commercial and industrial customers decrease their consumption to a specific level which have an incentive payment for them, as follows ($\forall t \in \Gamma_t$):

$$P_{i,t}^{cur} \leq PD_{i,t}^r \quad ; \forall i \in \Gamma_r \quad (20)$$

$$Q_{i,t}^{cur} \leq QD_{i,t}^r \quad ; \forall i \in \Gamma_r \quad (21)$$

$$PD_{i,t}^{cf} = (1 - \gamma_{i,t}^{flex}) PD_{i,t}^c \quad ; \forall i \in \Gamma_c \quad (22)$$

$$QD_{i,t}^{cf} = (1 - \gamma_{i,t}^{flex}) QD_{i,t}^c \quad ; \forall i \in \Gamma_c \quad (23)$$

$$PD_{i,t}^{df} = (1 - \gamma_{i,t}^{flex}) PD_{i,t}^d \quad ; \forall i \in \Gamma_d \quad (24)$$

$$QD_{i,t}^{df} = (1 - \gamma_{i,t}^{flex}) QD_{i,t}^d \quad ; \forall i \in \Gamma_d \quad (25)$$

$$0 \leq \gamma_{i,t}^{flex} \leq \gamma_{max}^{c/i} \quad (26)$$

where (20) and (21) are the amount of load curtailment in each bus at each hour which should be lower than that of residential load. Also, (22)-(25) state the demand decrement of commercial and industrial loads. Equation (26) states the maximum amount of flexibility provision by the flexible loads.

F. The limits on the capacity and number of WFs

The following is proposed to limit capacity and number of WFs ($\forall i \in \Gamma_{WF}$).

$$0 \leq P_{i,t}^{WF} \leq L_i^{WF} \times P_i^{WF,max} \times CF_{i,t}^{WF} \quad (27)$$

$$-tg(\varphi_{lead}) \times P_{i,t}^{WF} \times L_i^{WF} \leq Q_{i,t}^{WF} \leq L_i^{WF} \times tg(\varphi_{lag}) \times P_{i,t}^{WF} \quad (28)$$

$$\sum_{i \in \Gamma_b} L_i^{WF} \leq N_{max}^{WF} \quad (29)$$

where (27) and (28) show the active and reactive power limit of WFs, respectively. In order to optimally allocate the WFs within a network, a binary variable L_i^{WF} is defined which indicates either WF is installed at bus i (i.e. $L_i^{WF} = 1$), or not (i.e. $L_i^{WF} = 0$). Also, number of WFs that could be installed in the network should be limited. Consequently, equation (29) is proposed which specifies number of WFs.

G. The limits on the capacity and number of ESSs

The ESS constraints include the state of charge (SOC) at each hour, limits on SOC and charging/discharging power, constraint to prevent simultaneous charging/discharging, plus limits on the number of ESSs that could be installed, as follows

($\forall i \in \Gamma_{ESS}, \forall t \in \Gamma_t$):

$$SOC_{i,t}^{ESS} = SOC_{i,t}^{ESS} + \Delta t \cdot (P_{i,t}^{C_{ESS}} \eta_{i,t}^{C_{ESS}} - P_{i,t}^{D_{ESS}} / \eta_{i,t}^{D_{ESS}}) \quad (30)$$

$$SOC_i^{\min} \times L_i^{ESS} \leq SOC_{i,t}^{ESS} \leq SOC_i^{\max} \times L_i^{ESS} \quad (31)$$

$$0 \leq P_{i,t}^{C_{ESS}} \leq P_{i,t}^{C_{ESS,max}} \times L_i^{ESS} \quad ; \forall i \in \Gamma_{ESS} \quad (32)$$

$$0 \leq P_{i,t}^{D_{ESS}} \leq P_{i,t}^{D_{ESS,max}} \times L_i^{ESS} \quad ; \forall i \in \Gamma_{ESS} \quad (33)$$

$$P_{i,t}^{C_{ESS}} \times P_{i,t}^{D_{ESS}} = 0 \quad (34)$$

$$\sum_{t \in \Gamma_t} \sum_{i \in \Gamma_{ESS}} P_{i,t}^{C_{ESS}} \geq \sum_{t \in \Gamma_t} \sum_{i \in \Gamma_{ESS}} P_{i,t}^{D_{ESS}} \quad (35)$$

$$\sum_{i \in \Gamma_b} L_i^{ESS} \leq N_{max}^{ESS} \quad (36)$$

where SOC of ESSs is represented by (30) and limited by (31). Constraints (32) and (33) correspond to the upper and lower limit of charge/discharge power of ESSs, whereas (34) limits the simultaneous charge and discharge of ESSs. A binary variable L_i^{ESS} states the location of ESSs installed at system, i.e. $L_i^{ESS} = 1$ for the ESS located at bus i and i.e. $L_i^{ESS} = 0$, otherwise. Also, constraint (35) insures that charging level of the ESSs should not be smaller than discharging level. To limit the number of ESSs that could be installed at system, equation (36) is introduced.

H. The PEV-PLs' constraints

In this study, a model is proposed to limit the number of PEV-PLs, capacity of electric vehicles and number of electric vehicles of each PL. Also, to fully include the participation of PEVs in the contingency condition, a formulation is proposed to capture the participation of all available PEVs in the resilient operation of the grid. These constraints are expressed as follows: ($\forall i \in \Gamma_{PEV}, \forall t \in \Gamma_t$)

$$E_{i,t}^{PEV} = E_{i,t}^{PEV} + \Delta t \cdot (P_{i,t}^{C_{PEV}} \eta_{i,t}^{C_{PEV}} - P_{i,t}^{D_{PEV}} / \eta_{i,t}^{D_{PEV}}) \quad (37)$$

$$E_i^{\min} \times L_i^{PEV} \leq E_{i,t}^{PEV} \leq E_i^{\max} \times L_i^{PEV} \quad (38)$$

$$0 \leq P_{i,t}^{C_{PEV}} \leq P_i^{C_{PEV,max}} \times L_i^{PEV} \quad ; \forall i \in \Gamma_{PEV} \quad (39)$$

$$0 \leq P_{i,t}^{D_{PEV}} \leq P_i^{D_{PEV,max}} \times L_i^{PEV} \quad ; \forall i \in \Gamma_{PEV} \quad (40)$$

$$P_{i,t}^{C_{PEV}} \times P_{i,t}^{D_{PEV}} = 0 \quad (41)$$

$$\sum_{t \in \Gamma_t} \sum_{i \in \Gamma_{PEV}} P_{i,t}^{C_{PEV}} \geq \sum_{t \in \Gamma_t} \sum_{i \in \Gamma_{PEV}} P_{i,t}^{D_{PEV}} \quad (42)$$

$$\sum_{i \in \Gamma_b} L_i^{PEV} = N_{\max}^{PEV} \quad (43)$$

$$\sum_{t \in \Gamma_t} N_{i,t}^{PEV} = NM_{\max}^{PEV} \times L_i^{PEV} \quad (44)$$

$$N_{i,t}^{PEV} = Cap_{i,t}^{PEV} \times L_i^{PEV} \quad (45)$$

where constraints (37)-(41) are the limits in the capacity of PEVs' battery which include the energy stored at PEV (37), limit of energy that could be stored at PEV (38), maximum charging/discharging capacity of each PEV (39) and (40), and constraint on simultaneous charge/discharge of PEV (41). Based on the operation schedule of PEVs' battery, their charging capacity should be greater than their discharging capacity, as mathematically expressed by (42). Due to the noticeable advantages of PEVs and increasing trends in increasing the penetration of PEVs into the grid, deployment of PLs is vital. In this regard, equation (43) is introduced to insure the charging support for all available electric vehicles in the network. In this study, an integer variable $N_{i,t}^{PEV}$ is defined which indicates the number of electric vehicles in i^{th} PL at hour t . In the contingency condition, load supply has become an important issue and all of energy sources should participate in the demand supply. To capture the participation of all PEVs, all available electric vehicles should enter the PL during operation horizon. To do so, equation (44) is proposed. Also, equation (45) limits the number of electric vehicles in each hour due to the capacity of PLs. Please note that although the PEVs' behavior needs a practical model which considers different mechanical and electrical factors, this paper is associated with role of PEVs in normal and contingency condition, therefore, the proposed model deals with the PEVs battery along with optimal location and capacity of PEV-parking lots.

I. Decision variables and solution strategy

The optimal values obtained from the solutions of proposed optimization problem contain a number of decision variables which demonstrate the interconnection between the model variables. The independent decision variables (IDVs) of the proposed resilience-oriented co-operation model include: injected power from upstream network, active/reactive power of WFs, SOC of ESSs, status of PEV's battery, the participation of different load types, number of PEVs, and the hourly status of network switches. Besides, flow of the current through the transmission lines, voltage magnitude and angle of load buses, injected reactive of substation, active charge/discharge of ESS/PV battery for instance, are called dependent variables (DVs) as such their values are determined by solving the optimization problem. Sets of decision and independent variables are given by (46) and (47) respectively.

$$IDV = \left\{ \begin{array}{ll} P_{i,t}^{sub} & \forall i \in \Gamma_{sub}, \forall t \in \Gamma_t \\ (P/Q)_{i,t}^{WF} & \forall i \in \Gamma_{WF}, \forall t \in \Gamma_t \\ SOC_{i,t}^{ESS} & \forall i \in \Gamma_{ESS}, \forall t \in \Gamma_t \\ E_{i,t}^{PEV} & \forall i \in \Gamma_{PV}, \forall t \in \Gamma_t \\ \gamma_{i,t}^{flex} & \forall i \in \Gamma_b, \forall t \in \Gamma_t \\ N_{i,t}^{PEV} & \forall i \in \Gamma_{PV}, \forall t \in \Gamma_t \\ g_{ij,t} & \forall i, j \in \Gamma_b, \forall t \in \Gamma_t \end{array} \right\} \quad (46)$$

$$DV = \left\{ \begin{array}{ll} Q_{i,t}^{sub} & \forall i \in \Gamma_{sub}, \forall t \in \Gamma_t \\ P_{i,t}^{(C/D)_{ESS}} & \forall i \in \Gamma_{ESS}, \forall t \in \Gamma_t \\ P_{i,t}^{(C/D)_{PEV}} & \forall i \in \Gamma_{PV}, \forall t \in \Gamma_t \\ V_{i,t} & \forall i \in \Gamma_b, \forall t \in \Gamma_t \\ I_{(R/M)_{ij,t}} & \forall i, j \in \Gamma_b, \forall t \in \Gamma_t \end{array} \right\} \quad (47)$$

The introduced model is implemented in General Algebraic Modeling System (GAMS) software [27]. The proposed framework, is a mixed-integer non-linear programming (MINLP) model which is solved by the SBB solver. The SBB is a GAMS solver for solving the MINLP models. It is based on a combination of the well-known standard branch and bound technique from Mixed Integer Linear Programming (MILP) domain and some of the supported standard Nonlinear Programming (NLP) solvers by GAMS [27].

V. CASE STUDY

The IEEE 33-bus distribution test system [1], as shown in Fig. 2, is used to implement the proposed model. The system consists of 37 lines, 5 tie lines as well as 32 sectionalizing switches. Although, the used IEEE 33-bus test system is a moderately large case study for distribution level studies, but however, the proposed comprehensive framework of this study can be adapted to other large-scale networks with additional computation cost. It is to be noted that the selected optimization solver is a powerful one for solving the relatively large systems and there is no limitation in this part. Nonetheless, for extremely large scale networks, it may be necessary to either apply the mathematical decomposition techniques to break down the problem into some small sub-problems or linearize the nonlinear parts of the problem.

The proposed model, is executed on an Intel Core i7-3.00 GHz personal computer with 8 GB of RAM.

The paper presents results for a maximum of three PEV-PLs and maximum capacity of 40 PEVs in each hour. The focus of this study is on the collaborative operation of PEV along with other components of smart grid so as to reduce the amount of load curtailment in different conditions. Hence, 1500 PEVs are assumed to be in the network which should participate in the supply of system loads to decrease the load curtailment in contingency condition. This number of PEVs in the grid is adequate for the dimension of the given distribution network under study. It is worth mentioning that the same travel pattern is assumed for the drivers and focus is on the role of PEVs in severe contingency condition. Nonetheless, this research will also be conducted to incorporate the behavior of PEV owners as an uncertain parameter. The maximum and minimum SOC values of the battery of PEVs are assumed to be 90% and 10% respectively, while the nominal capacity of batteries considered to be 16 KWh. Also, rated charge and discharge capacity of the PEVs considered to be 2.3 KW.

TABLE II
CHARACTERISTICS OF EACH ESSs.

$P_{i,t}^{d_{ESS}} (KW)$	$P_{i,t}^{c_{ESS}} (KW)$	$\eta_{i,t}^{c_{ESS}}$	$\eta_{i,t}^{d_{ESS}}$	$SOC_i^{max} (KWh)$	$SOC_i^{min} (KWh)$
100	100	0.95	0.95	500	50

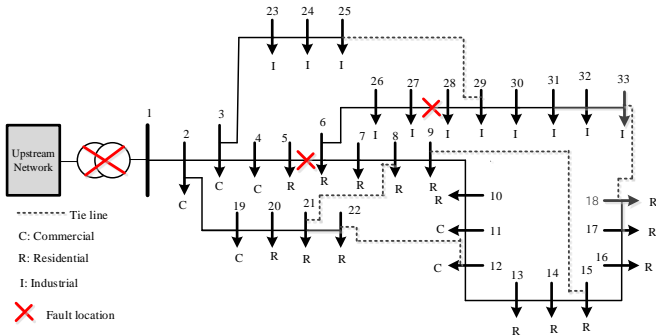

Fig. 2. The distribution system under study.

Type of each load (i.e. residential, commercial, and industrial) to the load buses are specified in Fig. 2, while variation of demand is shown in [28]. In addition, the maximum value of load flexibility index is set to 0.1. It is assumed that at the most three WFs with rated capacity of 800 KW, and two ESSs, are allowed to be dispatched in the system. Characteristics of ESSs are given in Table 2. The daily variation of WFs’ capacity factor is given in [28]. The contract price of purchasing power from WFs and main grid, loss of load value and price of load flexibility is assumed to be 0.04, 1, and 0.5 \$/KWh, respectively.

To capture the contingency condition in the operation horizon of the simulation, it is assumed that the substation and two power lines, connecting buses 5 to 6, and 27 to 28 are failed from hour 7 to 18, as a result of a natural disaster. The location of failures are given in Fig. 2. It is to be noted that the following assumptions are considered: (i) all the WTs have DFIG technologies and as a result they can contribute in the black start process; (ii) the DSO has been authorized for load curtailment in contingency conditions to maintain the frequency of the system.

VI. NUMERICAL RESULTS

This section summarizes the findings of the paper. To demonstrate the DNR importance, the results obtained for two cases including Case I: with DNR and PEV-PLs, and Case II: without DNR and PEV-PLs. The following sections describe the results obtained for each case.

A. Case I: Joint DNR and DER allocation model

In this case, the proposed model is solved while the on/off status of distribution line switches changed during a day. The value of the objective function in this case is \$3281.637. Fig. 3 shows the on/off status of line switches for the study horizon. This figure implies the importance of hourly network reconfiguration. As it can be seen from this figure, the status of some line switches does not change during the operation horizon. However, status of some of important power lines such as L₁₈₋₃₃ and L₆₋₂₆, which have key role in the system, is changed several times during a day. Also, the line switch L₁₋₂ is opened in hours 7 to 18, because the main grid is at fault in these hours; therefore, in these hours, the system experiences the islanded mode and the DERs supply the system, and as a result the complete blackout is not occurred.

The location of DERs in the initial configuration of system is shown in Fig. 4. It can be observed that the PEV-PLs installed at the commercial and industrial load buses to charge

in the off-peak periods and normal condition of system and inject it to the system in the on peak periods and contingency condition. The number of electric vehicles that should be in each PL during the operation horizon is summarized in Table 3. According to this table, total capacity of PLs located at buses 2, 11, and 33 is equal to 683, 616, and 201 electric vehicles, respectively. Comparison of this table and Fig. 3 imply the coordinated role of PEVs and DNR. For instance, the line which connects the PL installed at bus 2 closed during operation horizon.

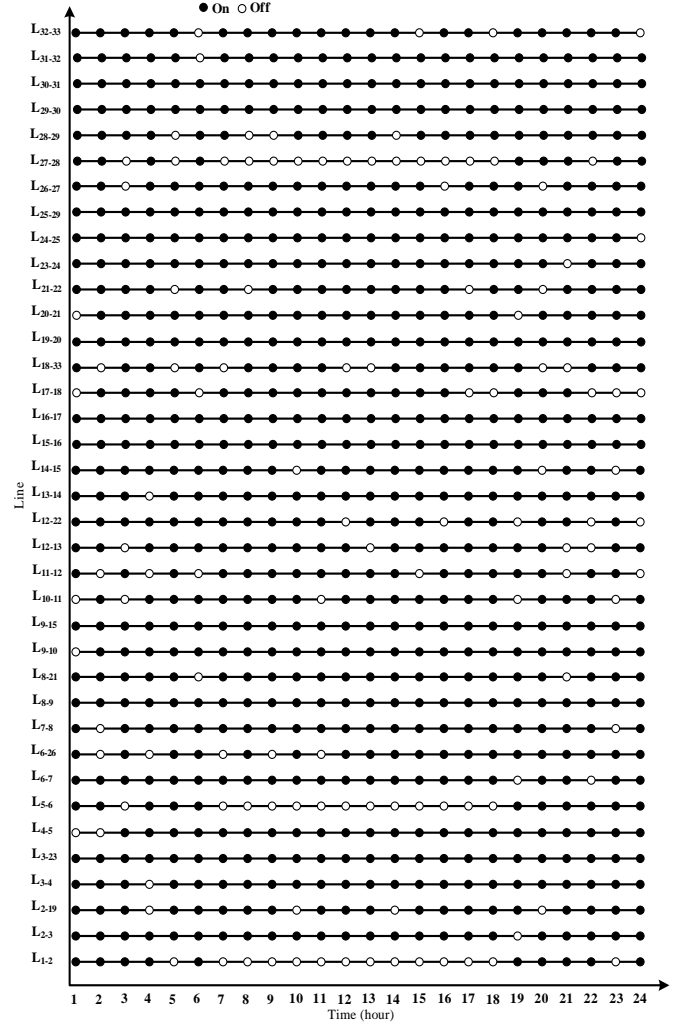

Fig. 3. The on/off status of line switches.

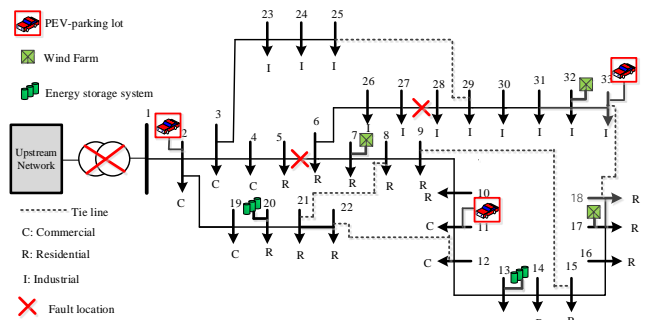

Fig. 4. Optimal location of DERs in the system in Case I.

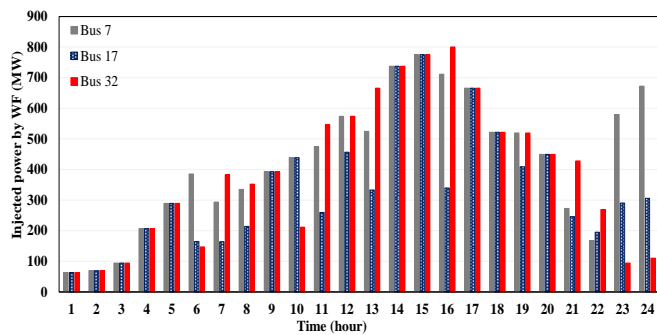

Fig. 5. Optimal active power of WFs in Case I.

The active power dispatch of WFs is depicted in Fig. 5. It can be observed that more active power is dispatched via WFs in hours that the network experiences the contingency condition. Also, state of charge of ESSs is shown in Fig. 6. As can be seen, in contingency time intervals, the charge of ESSs is dropped in such a way that in peak hours the SOC of ESSs is in their minimum level.

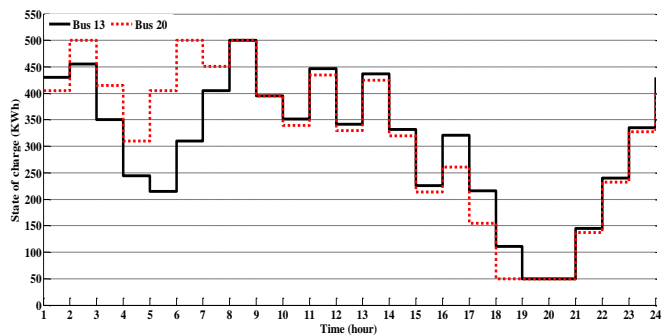

Fig. 6. SOC of the ESSs in Case I.

TABLE III
NUMBER OF PEVS IN EACH PEV-PL.

Time (hour)	Bus number			Time (hour)	Bus number		
	2	11	33		2	11	33
1	40	40	0	13	0	36	40
2	37	36	0	14	40	0	0
3	0	40	0	15	40	0	40
4	16	40	0	16	34	0	0
5	15	36	0	17	40	0	24
6	35	0	0	18	40	40	0
7	36	36	0	19	36	40	0
8	35	36	0	20	35	0	0
9	40	40	17	21	36	0	40
10	40	40	0	22	34	40	0
11	0	36	0	23	0	40	0
12	40	40	40	24	14	0	0

B. Case II: Without DNR and PEVs.

As previously mentioned, PEVs and DNR have a considerable effect on the smart grid economic and operational perspectives. In this regard, the proposed model is solved without the network reconfiguration and penetration of PEVs.

The figure for objective function in this case is \$3746.937. This is because there will be several loads which are disconnected from the distribution system and the capacity of DERs is not enough to support all system loads in contingency condition.

It is worth noting that for the sake of results comparison, the obtained results of this case are simultaneously illustrated with

that of Case I. Consequently, Fig. 7 depicts the optimal power dispatch of the proposed method for both cases. It can be seen that participation of customers is increased in Case II. Also, in Case I, some of active power injected from WFs and substation is consumed by PEVs. On the other hand, PEVs discharged in the on peak periods and act as storage systems. Furthermore, injected power from substation and WFs are decreased in Case I in result of PEVs discharge. Meanwhile, in Case I, islanded loads supplied through coordination of DERs and DNR which result in lower load curtailment.

Table 4 gives information on the computation size of the proposed model in both cases, and for two different computation systems.

TABLE IV
COMPUTATIONAL INFORMATION OF THE CASE STUDIES

Computation system	Intel Core i7-3.00 GHz, 8 GB RAM		Intel Core i7-3.40 GHz, 16 GB RAM	
	Case I	Case II	Case I	Case II
Number of model variables	19,685	12,841	19,685	12,841
Number of model iterations	26,153	129	20,043	129
Total execution time [s]	4,932	31	1045	18
Relative gap	0	0	0	0

VII. CONCLUSION AND FUTURE WORKS

This study proposed a methodology for simultaneous allocation of distributed energy resources and hourly network reconfiguration in normal and contingency condition. The introduced model provides a resilience-based architecture in which, some distribution line switches are opened for a specific time interval and optimal location and size of wind farms, plug-in electric vehicle-parking lots as well as energy storage systems are optimally defined along with on/off status of line switches for the operation horizon. Nonetheless, participation of customers in system management is investigated through the concept of load curtailment of residential consumers and flexibility of commercial and industrial consumers so as to preserve the system from complete blackout, during contingency condition. The obtained results substantiate the importance of simultaneous allocation of DERs and reconfiguration of distribution network, as well as demand response, in normal and contingency condition on the operation of the system.

In general, the numerical simulations allow that the following conclusions be drawn:

- Network reconfiguration problems should be solved on an hourly basis so as to improve the characteristics of network.
- Coordination of DERs planning and hourly network reconfiguration are important factors for increasing the resilience of distribution system.
- Optimal location and capacity of DERs can be affected by contingency conditions.
- End-users can play a crucial role in improving the system management in contingency condition.

Further research studies need to explore the effect of long-term planning of DERs on resilience of power systems. In this regard, the additional constraints including state of health (SOH) of energy storage and battery of the PEVs can be

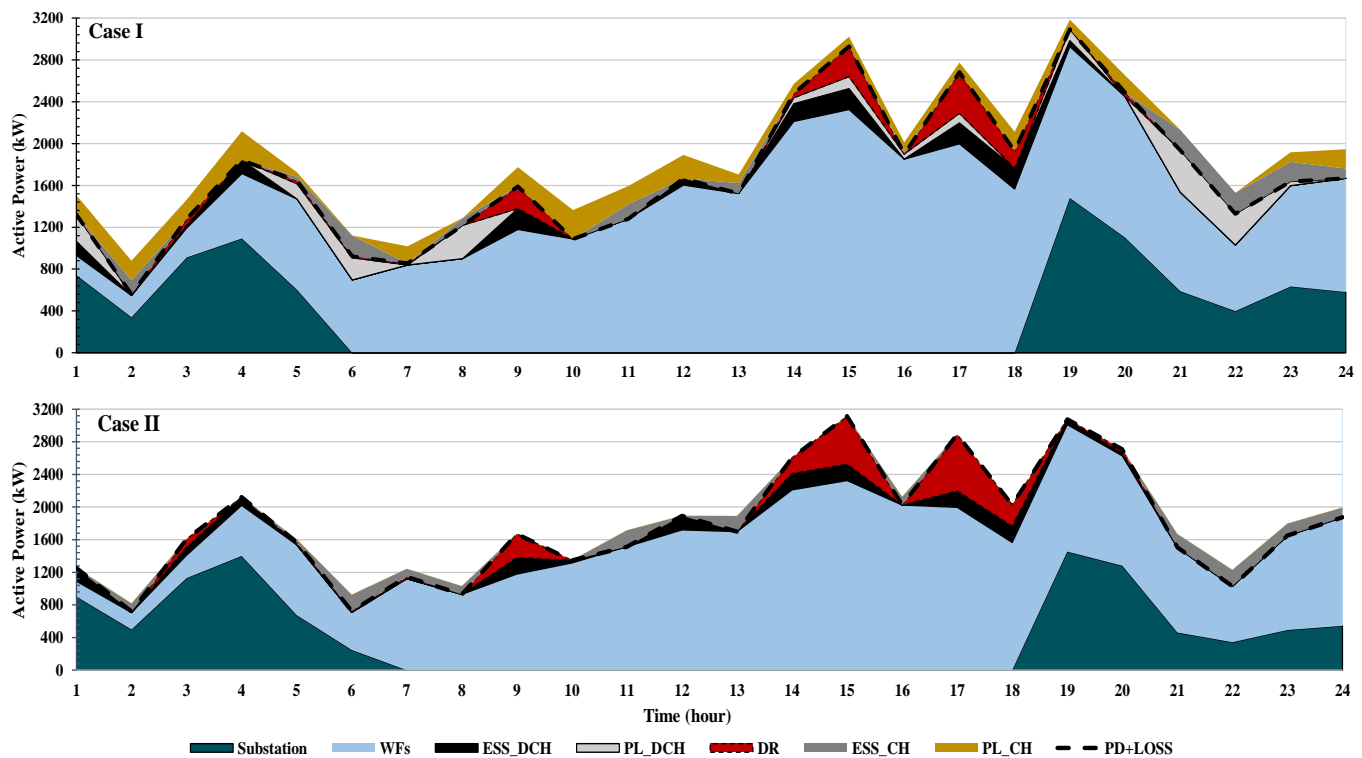

Fig. 7. Optimal power dispatch of different components of system for cases I and II

included in the model. Besides, although the paper focused on steady-state operation of the network, the consideration of dynamic behavior and transient stability of system in the contingency condition is of the utmost importance. Consequently, in future works, the interconnection between the hourly network reconfiguration and different aspects of the system, e.g. transient and steady-state stability, will also be analyzed.

ACKNOWLEDGEMENT

This work is carried out as part of the InteGRIDy project. InteGRIDy project is being financed by the European Commission under Grant agreement 731268.

REFERENCES

- [1] H. Arasteh, V. Vahidinasab, M. S. Sepasian, and J. G. Aghaei, "Stochastic System of Systems Architecture for Adaptive Expansion of Smart Distribution Grids," *IEEE Trans. Indust. Inform.*, Feb. 2018.
- [2] N. G. Paterakis, A. Mazza, S. F. Santos, O. Erdinç, G. Chicco, A. G. Bakirtzis, and J. P. Catalão, "Multi-objective reconfiguration of radial distribution systems using reliability indices," *IEEE Trans. Power Sys.*, vol. 31, no. 2, pp. 1048-1062, Mar. 2016.
- [3] A. El-Zonkoly, and L. dos Santos Coelho, "Optimal allocation, sizing of PHEV parking lots in distribution system," *Electr. Power Energy Syst.*, vol. 67, pp. 472-477, May. 2015.
- [4] M. Shafie-Khah, P. Siano, D. Z. Fitiwi, N. Mahmoudi, and J. P. Catalão, "An Innovative Two-Level Model for Electric Vehicle Parking Lots in Distribution Systems with Renewable Energy," *IEEE Trans. Smart Grid.*, vol. 9, no. 2, pp. 1506-1520, Jun. 2018.
- [5] S. Pirouzi, J. Aghaei, V. Vahidinasab, T. Niknam, and A. Khodaei, "Robust linear architecture for active/reactive power scheduling of EV integrated smart distribution networks," *Electr. Power Sys Res.*, vol. 155, pp. 8-20, Feb. 2018.
- [6] A. S. Awad, M. F. Shaaban, T. H. El-Fouly, E. F. El-Saadany, and M. M. Salama, "Optimal resource allocation and charging prices for benefit maximization in smart PEV-parking lots," *IEEE Trans. Sustain. Energy.*, vol. 8, no. 3, pp. 906-915, Jul. 2017.
- [7] M. Shafie-khah, E. Heydarian-Forushani, G. J. Osório, F. A. Gil, J. Aghaei, M. Barani, and J. P. Catalão, "Optimal behavior of electric vehicle parking lots as demand response aggregation agents," *IEEE Trans. Smart Grid.*, vol. 7, no. 6, pp. 2654-2665, Nov. 2016.
- [8] S. Pirouzi, J. Aghaei, T. Niknam, M. Shafie-khah, V. Vahidinasab, and J. P. Catalão, "Two alternative robust optimization models for flexible power management of electric vehicles in distribution networks," *Energy.*, vol. 141, pp. 635-651, Dec. 2017.
- [9] A. Gholami, T. Shekari, F. Aminifar, and M. Shahidehpour, "Microgrid scheduling with uncertainty: the quest for resilience," *IEEE Trans. Smart Grid.*, vol. 7, no. 6, pp. 2849-2858, Nov. 2016.
- [10] M. Nick, R. Cherkaoui, and M. Paolone, "Optimal planning of distributed energy storage systems in active distribution networks embedding grid reconfiguration," *IEEE Trans. Power Sys.*, vol. 33, pp. 1577-1590, Aug. 2017.
- [11] L. Bai, T. Jiang, F. Li, H. Chen, and X. Li, "Distributed energy storage planning in soft open point based active distribution networks incorporating network reconfiguration and DG reactive power capability," *Appl. Energy.*, vol. 210, pp. 1082-1091, Jan. 2018.
- [12] S. Nikkhah, and A. Rabiee, "Voltage stability constrained multi-objective optimisation model for long-term expansion planning of large-scale wind farms," *IET Gen. Transm. Distrib.*, vol. 12, pp. 548-555, Sep. 2017.
- [13] A. S. Awad, T. H. El-Fouly, and M. M. Salama, "Optimal ESS allocation for benefit maximization in distribution networks," *IEEE Trans. Smart Grid.*, vol. 8, no. 4, pp. 1668-1678, Jul. 2017.
- [14] V. Vahidinasab, "Optimal distributed energy resources planning in a competitive electricity market: multiobjective optimization and probabilistic design," *Renew. Energy.*, vol. 66, pp. 354-363, Jun. 2014.
- [15] S. Wen, H. Lan, Q. Fu, C. Y. David, and L. Zhang, "Economic allocation for energy storage system considering wind power distribution," *IEEE Trans. Power Sys.*, vol. 30, no. 2, pp. 644-652, Mar. 2015.
- [16] A. Rabiee, S. Nikkhah, and A. Soroudi, "Information gap decision theory to deal with long-term wind energy planning considering voltage stability," *Energy.*, vol. 147, pp. 451-463, Mar. 2018.
- [17] H. Arasteh, M. S. Sepasian, and V. Vahidinasab, "An aggregated model for coordinated planning and reconfiguration of electric distribution networks," *Energy.*, vol. 94, pp. 786-798, Jan. 2016.
- [18] A. M. Eldurssi, and R. M. O'Connell, "A fast nondominated sorting guided genetic algorithm for multi-objective power distribution system

reconfiguration problem,” *IEEE Trans. Power. Sys.*, vol. 30, no. 2, pp. 593-601, Mar. 2015.

- [19] A. R. Malekpour, T. Niknam, A. Pahwa, and A. K. Fard, “Multi-objective stochastic distribution feeder reconfiguration in systems with wind power generators and fuel cells using the point estimate method,” *IEEE Trans. Power Sys.*, vol. 28, no. 2, pp. 1483-1492, May. 2013.
- [20] Z. Ghofrani-Jahromi, M. Kazemi, and M. Ehsan, “Distribution switches upgrade for loss reduction and reliability improvement,” *IEEE Trans. Power. Del.*, vol. 30, no. 2, pp. 684-692, Apr. 2015.
- [21] T. Ding, Y. Lin, Z. Bie, and C. Chen, “A resilient microgrid formation strategy for load restoration considering master-slave distributed generators and topology reconfiguration,” *Appl. Energy.*, vol. 199, pp. 205-216, Aug. 2017.
- [22] Y. Lin, and Z. Bie, “Tri-level optimal hardening plan for a resilient distribution system considering reconfiguration and DG islanding,” *Appl. Energy.*, vol. 210, pp. 1266-1279, Jan. 2018.
- [23] R. Sharifi, S. Fathi, and V. Vahidinasab, “A review on demand-side tools in electricity market,” *Renew. Sus. Energy Rev.*, vol. 72, pp. 565-572, May. 2017.
- [24] H. Arasteh, M. Sepasian, and V. Vahidinasab, P. Siano, “SOS-based multiobjective distribution system expansion planning,” *Electr. Power Sys. Res.*, vol. 141, pp. 392-406, Dec. 2016.
- [25] X. Liu, M. Shahidehpour, Z. Li, X. Liu, Y. Cao, and Z. Bie, “Microgrids for enhancing the power grid resilience in extreme conditions,” *IEEE Trans. Smart Grid.*, vol. 8, no. 2, pp. 589-597, Mar. 2017.
- [26] J. Aghaei, M. I. Alizadeh, P. Siano, and A. Heidari, “Contribution of emergency demand response programs in power system reliability,” *Energy.*, vol. 103, pp. 688-696, May. 2016.
- [27] GAMS Development Corporation, “General Algebraic Modeling Systems (GAMS),” *Washington, DC, USA*, <http://www.gams.com>.
- [28] S. Nikkhhah and A. Rabiee, “A Joint Energy Storage Systems and Wind Farms Long-Term Planning Model Considering Voltage Stability,” *Operat. Plan. Anal. Energy Stor. Syst. Smart. Energy Hubs*: Springer, 2018, pp. 337-363.



Ehsan Kianmehr received his M.Sc. in Electrical Engineering from the Islamic Azad University, Iran, in 2014. He has been a Lecturer with the Department of Electrical and Computer Engineering, Islamic Azad University of Doroud Branch, Iran, since 2015. He has a solid background in power systems, optimization, and power system economics as well as power distribution and transmission networks. His research interests

mainly focus on power system operation and security, security constrained unit commitment analysis, energy storage, demand response and electricity markets.



Saman Nikkhhah received the B.Sc. degree in electrical engineering from Urmia University, Urmia, Iran, in 2013, and the M.Sc. degree in electrical power engineering from the University of Zanjan, Zanjan, in 2016. His research interests include power system economics, power system planning, power system operation, smart grids, power system resiliency, and security.



Vahid Vahidinasab (M’10–SM’17) received the B.Sc. degree from K. N. Toosi University of Technology, Tehran, Iran, in 2004, and the M.Sc. and Ph.D. degree from Iran University of Science and Technology, Tehran, Iran, in 2006 and 2010, respectively, all in electrical engineering. Since 2010, He has been with the Department of Electrical Engineering, Shahid Beheshti University (SBU). He has also initiated and managed SOHA Smart Energy Systems Laboratory at SBU. He has demonstrated a consistent track record of attracting external fund and he has managed several industrial projects and closely worked with several large complex national/international projects. Since 2018 he is a Research Associate at Newcastle University and collaborates on the inteGRIDy as an EU Horizon 2020 project.

His research interest is oriented to different research and technology aspects of energy systems integration, smart grids/microgrids/nanogrids design, operation and economics, and application of artificial intelligence and optimization methods in energy system studies (modeling, forecasting and optimization).

Dr. Vahidinasab is a senior member of the IEEE, member of the IEEE Power and Energy Society (PES) as well as IEEE Smart Grid Society.



Damian Giaouris received the B.Eng. degree in automation engineering from the Technological Educational Institute of Thessaloniki, Thessaloniki, Greece, in 2000, the B.Sc. degree and Postgraduate Certificate in mathematics from Open University, Milton Keynes, U.K., in 2009 and 2011, respectively, and the M.Sc. and Ph.D. degrees in the area of control of electrical systems from Newcastle

University, Newcastle upon Tyne, U.K., in 2001 and 2004, respectively. He was a Lecturer in Control Systems with Newcastle University, since 2004, before moving to the Centre for Research and Technology Hellas (Greece), in 2011. Since September 2015, he has been a Senior Lecturer in Control of Electrical Systems with Newcastle University. His research interests include control of power converters, power systems, smart grids, electric vehicles, and nonlinear dynamics of electrical systems. Dr. Giaouris has been an Associate Editor for IET Power Electronics and a Guest Associate Editor for the IEEE Journal on Emerging and Selected Topics in Circuits and Systems. Currently he is an Associated Editor for IEEE CAS II.



Philip C. Taylor (SM’12) received the Engineering Doctorate in the field of intelligent demand side management techniques from the University of Manchester Institute of Science and Technology (UMIST), Manchester, U.K., in 2001. He joined Newcastle University, Newcastle upon-Tyne, U.K., in April 2013 where he is the Head of the School of Engineering and holds the Siemens Chair of

Energy Systems. He is a visiting Professor at Nanyang Technological University in Singapore and he previously held the DONG Energy Chair in Renewable Energy and was a Director of the Durham Energy Institute.