

Communications of the IIMA

Volume 7 | Issue 4

Article 4

2007

The Research on System Framework and Application of Analytical CRM based on MAS

Pei Liu

Economics and Management School Beijing University of Technology

RanRan Li

Economics and Management School Beijing University of Technology

GuaRui Jiang

Economics and Management School Beijing University of Technology

Follow this and additional works at: <http://scholarworks.lib.csusb.edu/ciima>

Recommended Citation

Liu, Pei; Li, RanRan; and Jiang, GuaRui (2007) "The Research on System Framework and Application of Analytical CRM based on MAS," *Communications of the IIMA*: Vol. 7: Iss. 4, Article 4.

Available at: <http://scholarworks.lib.csusb.edu/ciima/vol7/iss4/4>

This Article is brought to you for free and open access by CSUSB ScholarWorks. It has been accepted for inclusion in Communications of the IIMA by an authorized administrator of CSUSB ScholarWorks. For more information, please contact scholarworks@csusb.edu.

The Research on System Framework and Application of Analytical CRM based on MAS

**Pei Liu
RanRan Li
GuoRui Jiang**

Economics and Management School
Beijing University of Technology, Beijing

ABSTRACT

This paper introduces MAS technology to construct the architecture of Analytical CRM System. Basis on the three-layer system architecture of Analytical CRM System, we design a system framework of Analytical CRM based on MAS, and provide the detailed working principle of the core agent: Business logic agent and data mining Agent. Finally, we develop a prototype system of customer value segmentation on the MAS platform Jade, and provide the key technology.

INTRODUCTION

Analytical CRM System is an intelligent system which can analyze the customer information and give a reasonable judgment of the value and the profit contribution of the customer. The judgment should be based on making the best use of customer information and utilizing both the quantitative and qualitative methods to reveal the rule of customer's activities, which help the enterprise to adopt reasonable customer strategy. So we should utilize the optimal data analysis method to analyze the customer datum.

Multi-Agent System (MAS) is a loose coupling agent network and these agents can solve problems exceeding each single agent's ability by cooperation. Multi-Agent System is autonomic, distributed and coordinative, and has the ability of self-organizing, learning and reasoning. So we can make full use of agent's characteristics such as intelligence, cooperation and adaptability to build a reliable, flexible, and extensible Analytical CRM with Multi-Agent technology. The system has strong reliability, flexibility and extensibility, which is considered as a feasible solution to complicated and open distributing question (Sycara, 1998).

There are several advantages to introduce MAS technology to the Analytical CRM System.

(1) Choosing data source automatically. By using agent technology, the system can ensure the consistency of the data source. The system can choose both structural and nonstructural data source automatically and intelligently, thereby reducing the complexity caused by heterogeneous data sources.

(2) Taking analyzing function and data mining algorithm apart. In the traditional Analytical CRM System the analyzing function and the data mining method are tightly coupling, which make the system difficult to make extension and the analyzing application result to be unilateral. In order to improve the accuracy the Analytical CRM System, we can take the analyzing function and data mining method apart and utilize several data mining methods to analyze a single target, and then choose the optimal data mining result, which would be more comprehensive and accuracy (Li, Liu & Liu, 2006).

(3) Realizing flexible management of the business process. From the sight of automation of the business process, the business process of the multi-module in present CRM products is set in advance, consequently leading the weakness of lacking of flexibility. The agent has the characteristic of independence, interactivity, reactivity which make it availing integrating every functional module and could reduce the interruption of information points across the modules, so that it can support the cooperation among functional module easily and the effective management of business process. By utilizing these characteristics of agent technology, the system can overcome the weakness of lacking of flexibility in order to realizing the flexible management of the business process across the

functional modules.

(4) Supporting effective collaboration among agents in CRM. From the sight of cooperation, each agent can communicate with other agents using the advanced agent language, such as KQML or ACL, making modules of the analytical CRM collaborating with each other much more effective.

THREE-LAYER SYSTEM FRAMEWORK OF ANALYTICAL CRM MODEL

Analytical CRM System has the features such as the large amount of data and the complicated analysis method, as well as the diversity of data request and analysis request. In response to the features above, the Analytical CRM model can be divided into three layers in accordance with the thinking of layered system: the user interface layer, application service layer, data service layer (Li, 2002).

There are two kinds of interfaces in the user interface layer: User-oriented interface and interface for supporting other parts of the enterprise CRM system. These two kinds of interfaces can accept external request, interact with external environment and the application service layer.

The Application service layer is in charge of the concrete process of business logic. For the sake of clarity, the application service layer can be divided into four parts as following. The transmission from top to bottom among those layers is control flow and in the opposite direction is data flow.

(1) Application organizing layer: It mainly deals with users' analysis request and the template of display the result users designated. It can decompose users' analysis request to several business problems which can be dealt with by the business logic layer, and organize the results of returning business process according to the template users required.

(2) Business logic layer: It can separate concrete assignments of business logic from data mining tasks, which will improve the extendibility of the system and reduce the coupling of the system.

(3) Analytical function processing layer: It encapsulates multivariate statistical analysis methods and data mining algorithms and other analytical methods in the system. It is the core of Analytical CRM, because any system used to deal with datum will ultimately rely on concrete algorithms.

(4) Data access layer: According to the metadata of data storage (data warehouse, ODS, etc.) of the bottom layer, it answers for translating data request into the request to every concrete data source, thereby providing the data accessing service which can shield the detailed storage of the bottom layer.

The Data service layer is in charge of establishing, maintenance and access of the data source from data warehouse, data marts and ODS etc. It also manages the metadata of each data storage section and provides the corresponding interface. Enterprises have huge complicated all kinds of internal data systems and CRM system needs a lot of external supporting datum in addition, so it's a very complicated process for data cleaning, data extraction, data transformation and data loading. As a result, data mining will make no sense without a successful subject oriented data warehouse and ODS.

Obviously, the application service layer is the main body of implementing the analysis logic function for the Analytical CRM.

THE FRAMEWORK DESIGN OF ANALYTICAL CRM SYSTEM BASED ON MAS

System functions and System framework

We divided the application service layer into several classes of agent: AMS(Agent Management System), DF(Directory Facilitator), ACC(Agent Communication Channel), CA(Customer Agent), AOA(Application

Organizing Agent), BLA(Business Logic Agent), DMA(Data Mining Agent), Data Service Agent(DSA). At the same time, these Agents are divided into several layers as following:

(1) Management layer: Management layer answers for the management of Multi-Agent platform. It implements the foundation framework based on FIPA(Foundation for Intelligent Physical Agents, www.fipa.org), which is used for the mutual communication between these agents.

This layer contains three MA (Management Agent): AMS, DF and ACC.

AMS manages the activity of Agent platform, including establishing agents and deleting them from it. It decides whether a certain agent can register in the platform, and monitor the agents' movement from this platform to another platform. Furthermore, AMS preserves all the indexes of the current agents on the platform. DF provides the Directory Facilitator service for the agents on the platform, and answers for the management of their catalog. Other agents can register their services into DF, and inquire the provider about a certain service. ACC takes charge of the bottom communication of the agents both inside and outside the platform. All the agents (containing DF and AMS) visit at least one ACC for the communication with other Agents.

(2) Customer layer: Customer Agent (CA): It works as a representative of users for interaction with the system. CA collects the analysis request from users and sends it to AOA. It takes over the return from AOA and lay out it to users.

(3) Business Logic layer: This layer has two kinds of agents: AOA and BLA.

AOA takes over the analysis request from CA, and divides it into several business issues and dispatches them to several related BLA; it takes over the results from a number of Business Logic Agents, reorganizes them in terms of users' requirement, and then sends them to CA.

BLA has encapsulated the concrete business logic model. The system structure that packages each business logics into agent is flexible, and it is quite convenient to add the new BLA in terms of requirement in such a system. The model base of BLA only stores the best business logic model. If there is no the best business logic model in model base, then the BLA compares a number of business logic models using the model evaluation knowledge from the knowledge base, and store the best one into knowledge base.

(4) Data mining layer: DMA (Data Mining Agent) encapsulates many concrete multivariate statistics and data mining algorithms. It takes over the data request and algorithm list from BLA and delivers the data request to DSA. Based on the dataset returned, it implements algorithm analysis by the algorithms from algorithm base in terms of the algorithm list, and finally returns the model result to BLA.

(5) Data Service layer: Data Service Agent: It takes over the data request from DMA, extracts the required data from data warehouse, implements data preparation according to the data request and returns the dataset which is prepared for latter analyzing to BLA.

The system framework is shown as Figure 1:

Figure 1: The system framework of Analytical CRM Based on multi-agent.

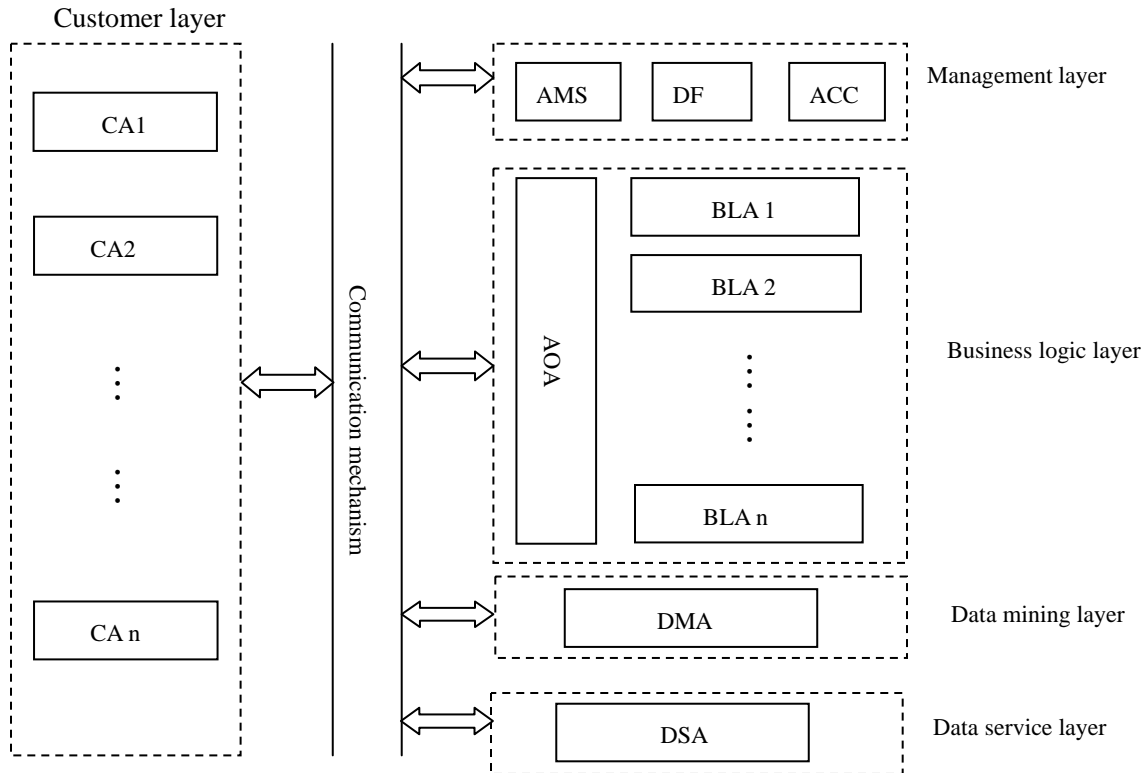

Where “CA_i” denotes the *i*th Customer Agent, “AMS” Agent Management System, “DF” Directory Facilitator, “ACC” Agent Communication Channel, “AOA” Application Organizing Agent, “BLA_i” the *i*th Business Logic Agent, “DMA” Data Mining Agent, “DSA” Data Service Agent.

Design of the BLA

Customer segmentation is one of the most important function of Analytical CRM, so we take CSA(Customer Segmentation Agent) for example to illustrate the working principle of BLA in Analytical CRM, the working principle of other BLA is the same.

The model structure is shown as Figure 2:

Figure 2: The model structure of Business Logic Agent.

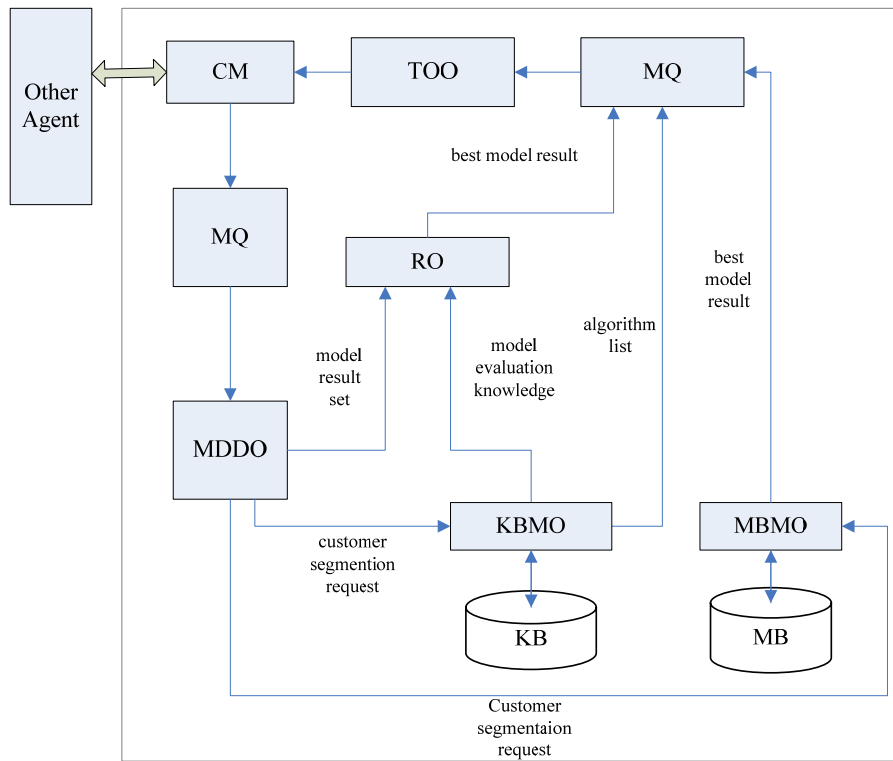

Where “CM” denotes Communication Model, “MQ” Message Queue, “MDDO” Message Distinguishing and Distributing Organ, “TOO” Task Output Organ, “RO” Reasoning Organ, “KBMO” Knowledge Base Management Organ, “MBMO” Model Base Management Organ, “KB” Knowledge Base, “MB” Model Base.

There are two kinds of messages that CSA take over: the request of customer segmentation and the set of model result. Customer segmentation request contains two important metalanguages: data mining parameters and data source. For example, a customer segmentation request could be described as “Segment the customers into 8 classes, according to the sales datum in 1998 and the customer value.” “Sales datum in 1998” is the description of data source, and “8 classes” is the description of data mining parameters. The two metalanguages: data mining parameters and data source also can be used as fields to query knowledge base and model base.

There are also two kinds of messages that sent by CSA: the best model result sent to AOA, and the data mining request sent to DMA.

The messages that CSA sent or take over are transmitted by Communication Model (CM). The messages sent by other agents are put into Message Queue (MQ), then the Message Distinguishing and Distributing Organ (MDDO) distinguishes the datum from these messages and distributes them; the datum put out by CSA are packaged by Task Output Organ (TOO) and sent to other agents. The Knowledge Base (KB) has two kinds of knowledge: model evaluation knowledge and the algorithm list that is used by customer segmentation frequently. The models stored in Model Base (MB) are the best model for diversified customer segmentation request respectively.

The working flow of CSA is as following:

- (1) If the message distinguished by MDDO is customer segmentation request, then the Model Management Organ (MMO) implements query in MB. If MB has the conformable model, then the CSA put out the model result through TOO; if no conformable model exists in MB, then Knowledge Base Management Organ (KBMO) queries

the algorithm list from KB and puts it into MQ. The algorithm list with the data mining parameters and data source from customer segmentation request together are packaged into data mining request, which is to be sent to DMA.

(2) If the message distinguished by MDDO is model result set, then the CSA sent it to Reasoning Organ (RO). Through reasoning by RO with the model evaluation knowledge from KB, the CSA puts out the best model result as well as storing it into MB.

Design of DMA

The model structure of DMA is shown as figure 3:

Figure 3: The model structure of Data Mining Agent.

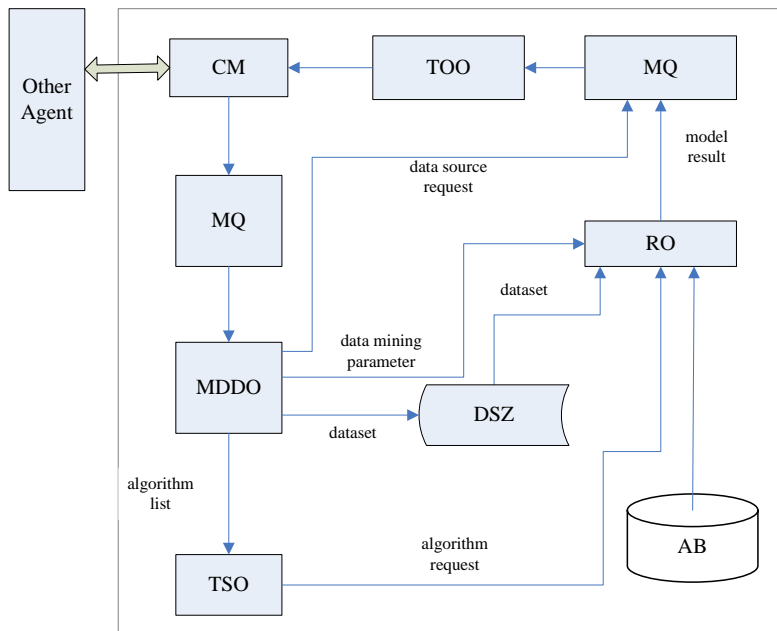

Where “CM” denotes Communication Model, “MQ” Message Queue, “MDDO” Message Distinguishing and Distributing Organ, “TSO” Task Scheduling Organ, “TOO” Task Output Organ, “RO” Reasoning Organ, “DSZ” Data Store Zone, “AB” Algorithm Base.

There are two kinds of messages that DMA take over: the data mining request sent by BLA and the dataset sent by DSA. Data mining request contains data source, data mining parameters and algorithm list.

There are also two kinds of messages that sent by DMA: the model result sent to BLA and data request sent to DSA.

MDDO takes charge of distinguishing and taking messages apart. If the message is data mining request, MDDO extracts data source request, data mining parameters and algorithm list from it. Then the data source request is sent to DSA for dataset through MQ; the data mining parameters are sent to RO; the algorithm list is sent to Task Scheduling Organ (TSO). If the message is dataset, MDDO puts it into Data Store Zone (DSZ).

TSO takes charge of scheduling the algorithms in algorithm list, and in turn sends the related algorithm request to DSA.

RO is in charge of concrete analyzing calculation by calling for the algorithm in Algorithm Base (AB) in terms of

algorithm request, and the dataset in DSZ. Through concrete data mining calculation, RO puts out model results to MQ.

TOO takes charge of packaging the model results in MQ into model result set message, and sends them to BLA through CM.

AN APPLICATION EXAMPLE

On the Basis of the Analytical CRM system framework based on MAS, we developed a prototype system on Jade, which is a popular MAS development platform. This prototype system realized a customer value segmentation method based on AHP (CVS-AHP) (Jiang, Liu & Huang, 2007).

A MAS development platform—Jade

Jade is a software development framework of interactive MAS system, which complies with FIPA standards. It makes the application development based on agent more easily (jade.tilab.com, 2005). Jade provides a suit of comprehensive system services and agents to simplify the application development. The interactive language used in Jade is ACL (Agent Communication Language)^[4], which is the standard agent communication language defined by FIPA. ACL language is based on the theory of Speech-Act, and its message expresses the communication action, which is to say, agent attempt to achieve or accomplish a specific intention and action by sending messages. It includes more than 20 so-called communicative act and corresponding grammars and semantic expressions. Each communicative act is composed of title (indicating the message type, meaning, and communication intention) and message parameters.

System function and its interactive structure

According to the requirement, we divided the agents in customer value segmentation system based on MAS into three kinds: CA (Customer Agent), CSA (Customer Segmentation Agent)¹ and DSA (Data Service Agent).

Customer Agent mainly implements the following functions: putting in the weight parameters of AHP to weigh the related data in dataset, and sending the data preparation service request to DSA; taking over the dataset prepared by DSA, using k-means algorithm to implement analysis process on it, and then returning the analysis results to CA.

DSA mainly deals with the raw dataset from data warehouse according to customer's concrete data request, consequently providing the dataset customer need. It has the following functions: taking over the data preparing request from customers, taking out the raw dataset from warehouse of datum and prepare the dataset of customer need; taking over the data request from CSA, and returning the dataset prepared to CSA for analyzing.

The interactive structure is shown as figure 4:

¹ Due to CVS-AHP need not to compare several model results, we integrated the function of DMA into CSA

Figure 4: The interactive structure of Agents in the system.

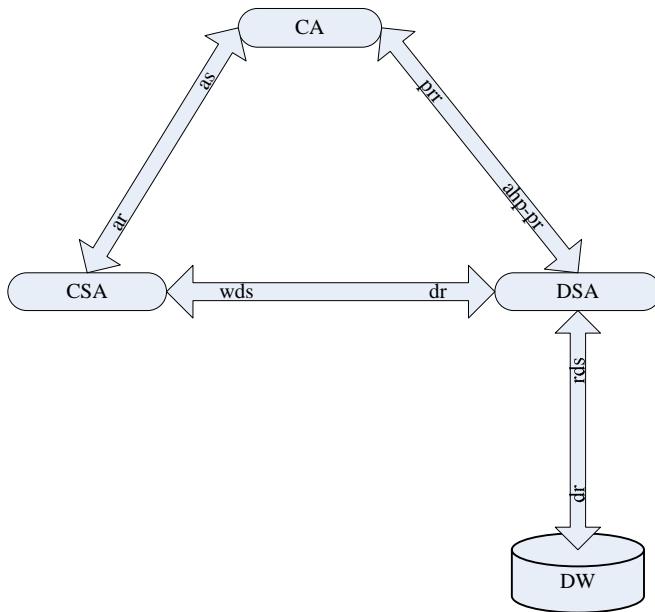

ar: analysis request
 as: analysis result
 prr: parameter request reply
 pr: parameter request
 wds: weighed dataset
 dr: data request
 rds: raw dataset

The message interactive mechanism design

According the segmentation of business process, the interaction of messages in the system is divided into two kinds: the interaction of message when customer requests the data service and the other when customer requests customer segmentation. Both the initiator and recipient is customer Agent.

The working flow of the first kind of message interaction is: CA sends the weight parameter of AHP to DSA. DSA reply the parameters request to CA on the basis of the data preparation by DSA.

The characteristic of the first kind of message is the few data transmitted. We can use the standard message mechanism to resolve it, which is using “content” field to transmit a string. For example, the message format that CA sends data preparing request to DSA is as following:

```
(inform
:sender CA
:receiver DSA
:content (weigh parameter of AHP )
:language ...
:conversationId ...
)
```

The working flow of the second kind of message interaction is: CA sends analysis request to CSA, and then CSA sends data request to DSA; DSA takes over the data request, prepares the dataset according to the data request and

sends it to CSA; On the basis of analysis processing on dataset returned, CSA returns the analysis result to CA. The characteristic of the second kind of message is the great amount of data transmitted. The dataset that DSA sends to CSA and the analysis result that CSA sends to CA belong to this kind. It is obviously that it is difficult to realize this kind of message transmission mechanism by standard message mechanism. The API in Jade provides the method transmitting object, so we encapsulate the dataset or the analysis result into object which need be transmitted.

We make the object transmitted and all the objects comprised in it serialized, and then utilize the methods: "setContentObject" and "getContentObject" provided in jade which could transmit serialized objects. In this way, we can implement transmitting objects as the content of ACL message.

For example, when DSA transmits the dataset to CSA, the segment of concrete code is as following:

```

DSA of sending end:
    SegReply.setLanguage("JavaSerialization"); //define the type of ACL language
    SegReply.setContentObject(pdataPoints); // set dataset object as message content
    myAgent.send(SegReply); //DSA send message

CSA of receiving end:
    if ("JavaSerialization".equals(msgfromD.getLanguage())) //check the type of ACL message
    {dataPoints = (Vector) msgfromD.getContentObject();} // accept dataset object
    "SegReply" denotes the ACL message from DSA to CSA.

```

CONCLUSION

Applying the MAS technology into Analytical CRM is an embodiment of the intelligence of Analytical CRM. MAS technology can not only reduce the coupling degree among the modules of Analytical CRM system, so that improve the flexibility and extendibility of business process of it, but also make the best use of the ability that MAS system solving complicated problem, and so it is in favor of the collaborative working among the modules of Analytical CRM effectively.

This paper brought forward the Analytical CRM system framework based on MAS technology. Through the detailed research of the working principle of several core agents, we developed a prototype system which can be used in customer value segmentation, and consequently demonstrates the effectiveness and feasibility of MAS introducing to Analytical CRM system.

REFERENCES

- 1 Sycara K. P. (1998). Multiagent systems. *AI magazine* [J], summer,79~92.
- 2 LI Bin, LIU Wen Huang, LI Xiu. (2006). Intelligent Information Architecture of Analytical Type CRM[J], *Aerial manufacture technology*, (11):94-97.
- 3 LI Hai Ming. (2002). The software Architecture of Analytical CRM[J]. *Computer engineering and application*. (5):110-112.
- 4 <http://www.fipa.org/specs/fipa00018/OC00018A.pdf>. FIPA 97 Specification, Part2, Agent Communication Language. Technical Committee of FIPA.
- 5 JIANG Guo Rui, LIU Pei, HUANG Ti Hun. (2007). Research of customer value segmentation based on AHP method[J]. *Computer engineering and application*. (8):238-241.
- 6 <http://jade.tilab.com/doc/programmersguide.pdf>. JADE Programmer's GUIDE. 2005.

