

2007

A Network Stability Monitoring Mechanism of Cluster-Oriented Wireless Sensor Network

Kuo-Qin Yan

Chaoyang University of Technology, Taiwan

Shu-Ching Wang

Chaoyang University of Technology, Taiwan

Yu-Ping Tung

Chaoyang University of Technology, Taiwan

Follow this and additional works at: <http://scholarworks.lib.csusb.edu/ciima>

Recommended Citation

Yan, Kuo-Qin; Wang, Shu-Ching; and Tung, Yu-Ping (2007) "A Network Stability Monitoring Mechanism of Cluster-Oriented Wireless Sensor Network," *Communications of the IIMA*: Vol. 7: Iss. 4, Article 3.

Available at: <http://scholarworks.lib.csusb.edu/ciima/vol7/iss4/3>

This Article is brought to you for free and open access by CSUSB ScholarWorks. It has been accepted for inclusion in Communications of the IIMA by an authorized administrator of CSUSB ScholarWorks. For more information, please contact scholarworks@csusb.edu.

A Network Stability Monitoring Mechanism of Cluster-Oriented Wireless Sensor Network

Kuo-Qin Yan
Shu-Ching Wang
Yu-Ping Tung

Chaoyang University of Technology, Taiwan

ABSTRACT

In wireless sensor network (WSN), every sensor node could active dynamically. Therefore, those sensor nodes will affect the stability of network topology because of clustering and de-clustering, and continuously make reconfiguration for the clusters of wireless sensor network, all that will influence the overall function of network. It is an important issue that how to elect a cluster manager (CM) to keep the stability of network topology. In addition, large amount of events maybe flood suddenly in a local area. Such the case might raise the overload of CM, even lead CM to fail or crash and the WSN topology maybe self-organized. However, a mechanism needs to be considered that allows coping with the additional loads and can balance the workload of CM. In this study, a preventable and supportable monitor mechanism to avoid CM overload cause network unstable and to reduce load imbalance problem is proposed. Hence, it can prolong lifetime of network and raise performance of network efficiently.

INTRODUCTION

With the explosion of wireless network, the activity of mankind has been impacted, in the infrastructure network structure; the medium for fixing center will be regarded as the relay station to bringing about the connection of two mobile equipments, so that the data is transmitted (Akyildiz, Weilian, Sankarasubramaniam, & Cayiric, 2002). The relay station, such as Access Point (AP), was given an excellent feature to control the position of mobile equipments, which is just the same as the router. But these equipments are usually damaged by the extrinsic factors such as the war, natural disasters, etc., which will cause the failure connection between the nodes, therefore, the traditional wireless network has failed to meet the needs of mankind (CM, 2003). In recent years, the advance of technology and rapid development of Micro-Electro-Mechanical Systems (MEMS) have facilitated the rapid growth of non-infrastructure network structure, in which, Wireless Sensor Networks (WSNs) is purposed to be free to gain information at anytime and anywhere under a non-infrastructure network structure for meeting the needs of mankind (Akkaya & Younis, 2005; Heinzelman, Chandrakasan & Balakrishnan, 2002; Laerhoven, Lo & Ng, 2004; Lindsey & Ragavenda, 2002; Mhatre, Rosenberg, Kofman, Mazumdar & Shroff, 2004; Shen, Zhang, & Zhong, 2006; Younis & Fahmy, 2004). Therefore, variety of applications in WSNs are paid attention and developed. There are typically four kinds of applications such as the environment observation, military, building and healthcare monitoring, etc. in WSNs.

Environmental observation includes: 1) to detect and examine the water quality near the chemical factory whether the water is polluted; 2) to detect and examine the forest fire and put forward a alarm when the forest fire is happened; 3) the pollution of the air is monitored; 4) to obtain humidity, pressure and temperature, etc. in specific ecological environment and track the whereabouts of the rare animals.

Due to characteristics of WSNs (the rapid deployment, self-organization, and fault tolerance etc.), more apply to track the positions of combat tank and intelligence of enemy in the battlefield quickly and contiguously. Military monitoring is the first idea at applications of WSNs.

By building monitoring (BA, 2006), old buildings may endanger householders' safety due to structure of the buildings that are happened some changes. These changes can be detected and examined; WSNs allow a

non-invasive means of monitoring and diagnosing moisture and slant levels, pollutants or gas detection to ensure safety, comfort and regulatory compliance in buildings.

In healthcare monitoring (Lindsey & Raghavenda, 2002), wireless physiological sensors which wearable and implantable two kinds of types are used to measure the status of the patient.

Viewed in this light, WSNs can offer many valuable applications. However, the limitations of hardware that make the control of energy consumption to become the primary considered factor in various kinds of relevant research of WSNs (Lin, Su, Hwang & Dow, 2005; Qing, Zhu, & Wang, 2006; Younis & Fahmy, 2004). Furthermore, the capability of memory, the computation of processor, and the communication capability are fairly limited. Therefore, even if the technology of the hardware improves continuously, but the energy problem remains a significance to challenge. In order to reduce the energy consumption, how to design a network topology of saving energy effectively, it is paid attention topic when we study WSNs (Heinzelman, Chandrakasan, & Balakrishnan, 2002).

Figure 1 presents the operation of WSN. These scattered sensor nodes (SNs) are usually deployed randomly in a sensing area that we are interested. Each SN is an independent individual, and can be self-organized (Krishnan & Starobinski, 2006), which means the process of autonomous formation of connectivity, addressing, and routing structures. By self-organization, SNs can start to collect and fusion these physical data and route data, which is aggregated back to the Sink or Base Station (BS) by multi-hops. In Figure 1, node A communicates with Sink to deliver messages, will route A to E or E to A by multi-hops. The Sink may communicate with the task manager node via internet or satellite to deliver data that is aggregated. In addition, the task manager node will use these aggregated data to make relevant analysis and applications.

Figure 1: The operation of WSN.

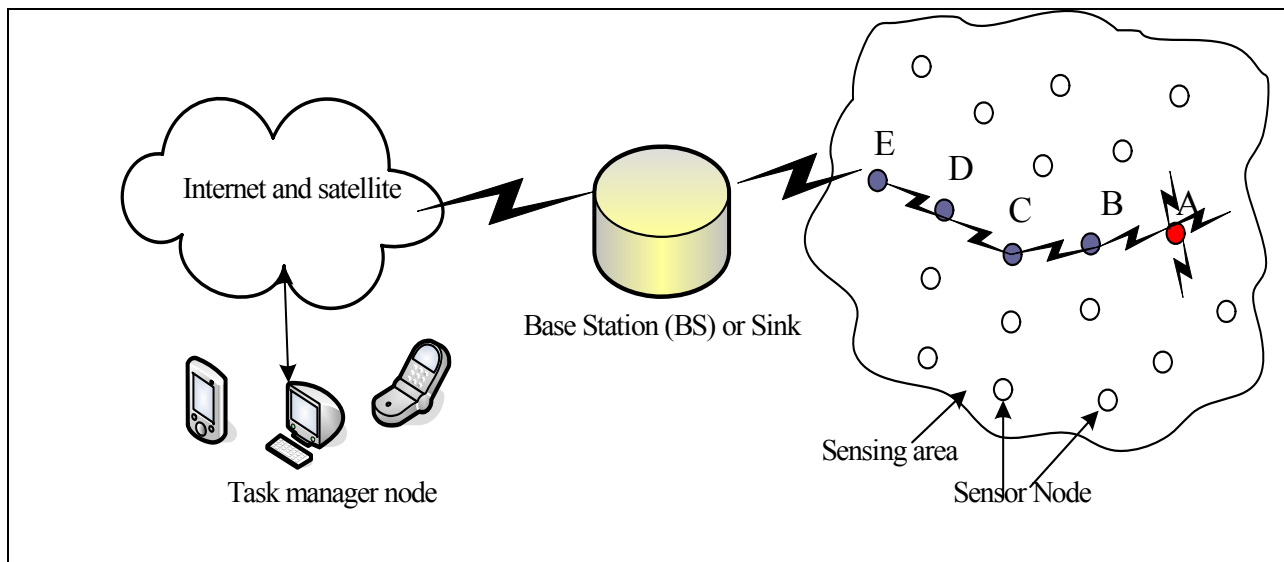

However, Figure 1 is a flat network topology, the broadcast storm and information collision problems will be happened when the large amount and repeated of messages flooding in the network is produced by using on-demand routing. These problems both waste energy of SNs quickly and cause instable of WSN (Indranil, Riordan & Srinivas, 2005).

Therefore, clustering is a key technology for reducing energy consumption in WSN. Through clustering, the scalable and lifetime of wireless sensor network can be raised. There is a cluster manager (CM) in each cluster, which transfers and receives data from members of cluster, aggregates data and transfer aggregated data to Sink or BS in a clustering topology. Figure 2 shows the role of CM. The objectives of CM can be divided into intra-cluster and

inter-cluster. In the intra-cluster, CM needs to do data aggregation, and transmission, and the communication with other SNs in the same cluster. In the inter-cluster, CM needs to do the communication with Sink and other CMs. Therefore, the workload of CM needs to be considered, and the part of workload in CM can be taken over or handoff actively. Then, the new CM re-electing or the network de-clustering will be avoided. To save overload problem is our discussed issue, this goal can achieve to prolong the lifetime of CM and to provide a stable topology of wireless sensor network. Hence, the lifetime of whole network can be prolonged and the performance of network can be raised efficiently.

Figure 2: The objectives of CM.

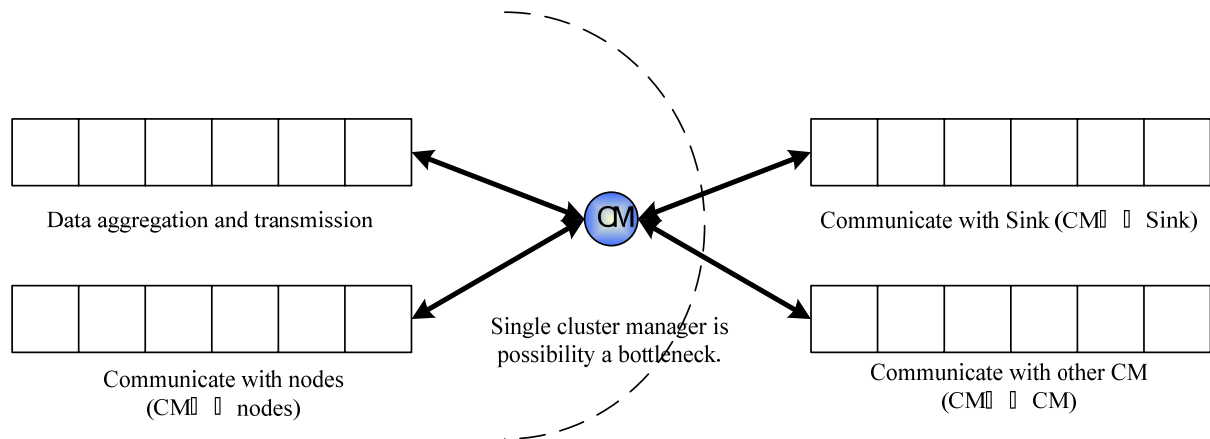

In this study, a high capability sensor node is elected to take a CM in a cluster-based WSN. Afterward, a Backup Manager (BM) is elected to take a part of workload in CM when CM is busy. The proposed method can avoid CM to become a bottleneck and reduce the lifetime of CM rapid. In other words, the concept of “slow-start” [3] is used in the operation of BM with taking a part of workload in CM except handoff when CM failed, crash or energy lower.

Such as practice can avoid large amount events suddenly flooding lead to overload of CM in a short period even CM crash, fail, or consume too much energy. Moreover, when SNs communicate with CM break down, or processor of CM is over busy are also can be solved. The mechanism is proposed to solve the two problems. Hence, the objectives of this paper are following as:

- (1) By using the concept of “slow-start”, the BM can take a part of works of CM when CM is busy. Moreover, CM retrieves the allotted works by “slow-start” when the performance of CM returns to normal.
- (2) The concept of “slow-start” is utilized in our study, which a TCP communication protocol is extend to solve the problem of CM busy or lack of communication.

Through the mechanism proposed in this study, the load balance of CM can be achieved, furthermore, the energy consumption of CM can be reduced, the lifetime of network can be prolonged and the performance of network can rose efficiently.

The remainder of the paper is organized as follows: Section 2 presents related works and classification of clustering protocols. In section 3, a monitor mechanism in cluster-based WSN is proposed. Section 4, an evacuated mechanism of CM’s workload in cluster-oriented WSN is proposed. Finally, section 5 concludes this paper.

RELATED WORK

Data aggregation is an important work for saving energy consumption whether static or dynamic WSNs. For data aggregation, certain amount of sensors in the vicinity form a team to aggregate data. Therefore, WSN is made up of several clusters of sensors, and several clusters may make up of more large clusters to form hierarchical structure in

whole network..

Hierarchical clustering management structure is one of effective reducing energy load structure, and it can reduce the number of transmission information in whole network and raise the number of effective transmission information. Stand on election methods of CM different, there are two kinds, distributed and centralized.

The difference of the distributed and centralized methods is the election of CM by decisive information. The distributed method uses the local information of each sensor node to elect CMs. The centralized method uses the whole network information that gathering by sink or BS to elect the most suitable node to take CM. Hence, the elected CM by centralized method is more stable and robust. However, SN must report the related information (ex. energy state, position etc.) of itself periodically then the overhead of network will be raised.

On the contrary, distributed methods only need local information to elect suitable CM in the local area. Therefore, it can avoid high overhead drawback. Nevertheless, to elect CM by using local information may cause the overload due to characteristic of random deployment. However, distributed WSN is close to the practical applications at present, our study will in such environment.

According to study in the past, how to process fails in the CM does not to be considered explicitly. Hence, in this paper, a backup manager mechanism is proposed in a distributed clustering environment to prevent that CMs are happened fails cause whole network instable even de-clustering. Besides, the local information is used to elect CM may cause overload in part of CMs. We aim at this problem and propose a load monitor mechanism in WSN.

CLUSTER-ORIENTED WIRELESS SENSOR NETWORK AND NETWORK MONITOR MECHANISM

Energy is a key hardware resource of SN to support all operations in the WSN. Other critical factors include bandwidth, memory and processor capability etc. will affect the performance of the CM. Therefore, there are multiple factors is considered to elect the CM. To simplify the complexity of this research, we assume that each SN can become aware of own position, that is to say, each SN is provided with position equipment.

The communication of WSN has divided into three phases such as the initial, active and inactive. At the initial phase, no CM has been elected. Therefore, each SN is the common node under this phase and the CM needs to be elected. When each SN starts to process tasks and CM starts to gather information is in active phase also called the stable state. When CM maybe fails and leads to network instable, we called inactive phase and handoff by BM. Due to the monitor mechanism of actively handoff, the lifetime of the whole network can be prolonged. Hence, the sensor node has divided into three roles such as the SN, CM and BM.

The formula (4) for calculating capability of SN considers four factors: percentage of energy (e), busy degree of processor (b), communication capability (c) and distance with center of gravity (D). According to the formula (4), which will be delivered to the SNs surrounded as the basis of CM election, while the weight values $w_1, w_2, w_3,$ and w_4 will be defined in accordance with the important of each item of factors for meeting the various needs in different specific applications to compute capability of each SN and elect appropriate CM. The formula (1), (2), and (3) explain formula (4) how to calculate center of gravity.

$$CX_j = \frac{\sum_i X_{ji}}{i} \tag{1}$$

$$CY_j = \frac{\sum_i Y_{ji}}{i} \tag{2}$$

$$D_{ji} = \sqrt{(X_{ji} - CX_{ji})^2 + (Y_{ji} - CY_{ji})^2} \tag{3}$$

$$p = (e) * w_1 + (1/b) * w_2 + (c) * w_3 + (1/D) * w_4 \quad \sum_{i=1}^4 w_i = 1 \quad (4)$$

When a new CM is elected, the ID and the capability of each SN in the same cluster will be recorded and the BM which the highest capability of SNs in the same cluster is elected. Afterward, the BM is elected, the CM broadcasts “who is BM” to all SNs in the same cluster. Moreover, when the CM has failed, SNs will notify the BM to become new CM and take over the cluster.

Although we use various factors and collocate respective weight to elect the suitable CM to manage the cluster. However, the workload of a CM is more than other SNs such as to send and receive data inter-cluster, to process data aggregation, and to transmit the aggregated data to sink. Moreover, the resource of a SN is limited, when a CM prunes overload, a new CM maybe needs to elected again and the cluster is instable. Therefore, two kinds of states must be considered: one is to process the BM taking the CM when CM is in fail; the other is to control the performance when CM is busy.

When the CM has failed, the SN in the same cluster enters to the inactive phase and the BM is started to become a new CM. If the BM is unable to start, the cluster will be de-clustering and re-clustering. Such case will influence the stability of the network and raise the maintenance cost.

Aim for avoiding the overload of a CM, three factors: percentage of energy (e), busy degree of processor (b), and communication capability (c) are used to estimate load capability of a CM. However, the load capability computing, the energy of CM, the quality of communication and the state of processor can be monitored. Hence, the formula (5) is extended from the formula (4) where L is the “load monitor function of CM”. Each CM computes the value of “load monitor function of CM” (L) by using formula (6) [14,15].

$$p=L + (1/D)*w_4 \quad (5)$$

$$L=(e)*w_1+(1/b)*w_2+(c)*w_3 \quad (6)$$

In addition, a threshold is set in accordance with the requirements of application. The threshold must aim at heterogeneous or homogeneous WSN. In a heterogeneous WSN, the capability of each SN is different such as energy, processor, and communication. However, in a homogeneous WSN, the capability of each SN is same. The threshold of SN in heterogeneous WSN can estimate by practical value such as energy has 20 Joules (assume the initial energy is 100 Joules) or the processor is used 80 percent. Hence, the threshold of SN in heterogeneous WSN can use the practical value directly. In this paper, a homogeneous WSN is adopted and “threshold of load capability function (L_t)” is given in formula (7) while the weight values t_1 , t_2 , and t_3 will be defined.

$$L_t=(e)*t_1+(1/b)*t_2+(c)*t_3 \quad (7)$$

L_t is the threshold of load capability function, and t_1 , t_2 , and t_3 represent the weight of threshold factor that include (e), (b), and (c).

If the L of CM is less than the threshold L_t , then CM needs to do load determination procedure. According to the concept of “slow-start”, a part of workloads of CM is assigned to the BM. Until the CM returns to normal work loading, the BM will give the work authority back to CM. In section 4, the detail description of an evacuated mechanism of CM’s workload is given.

EVACIATED MECHANISM OF CM’S WORKLOAD

In this section, the evacuated mechanism of CM’s workload is explained to show how to assign the part of works to the BM to execute when the CM has overloaded, and the CM retrieves work authority of BM when the CM returns

normal performance.

The objectives of CM can be divided into intra-cluster and inter-cluster, as shown in Figure 2. Therefore, the CM in workload of data aggregation is assisted to lighten by the BM. Figure 3 shows the original takes of CM charges of work content, and the workload of data aggregation in CM is assisted by BM.

Figure 3: The load of CM is assisted by BM.

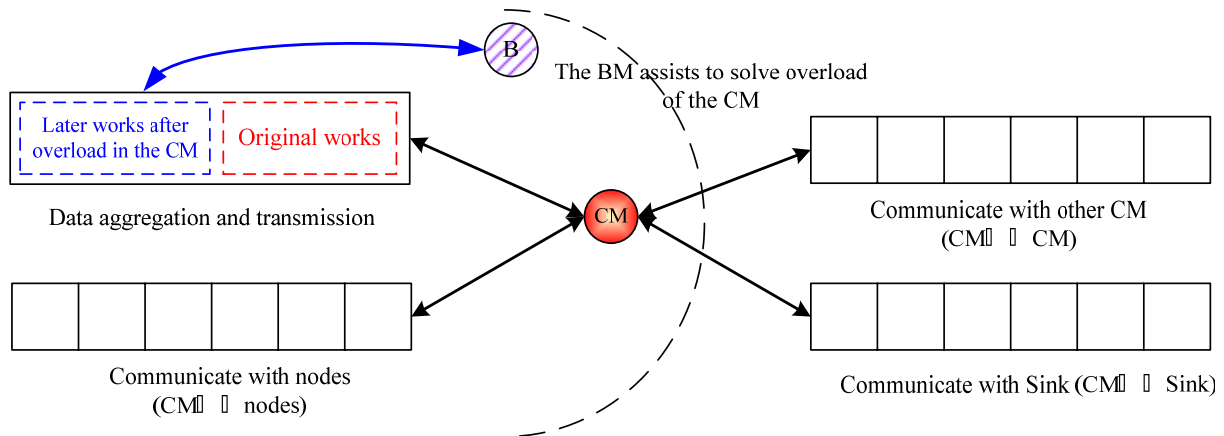

When the value of “load monitor function of CM” (L) is less than L_t , the CM will broadcast the “I am busy” message to all SNs in the cluster include the BM. Therefore, the sensed data of SN will be turned to require services by the BM that only take over works of data aggregation after the CM has broadcasted the message, but original workload of the CM needs to be finished by himself.

After a while, the CM returns to the normal performance by assistance of the BM, CM will broadcast “I am ready” message to each SN in the cluster. Hence, new works of data aggregation will be served by the original CM; the works of data aggregation in the BM need to be processed until finished, and the BM gives fusion of data back to the CM, the process is shown in Figure 4.

Figure 4: The CM retrieves work authority.

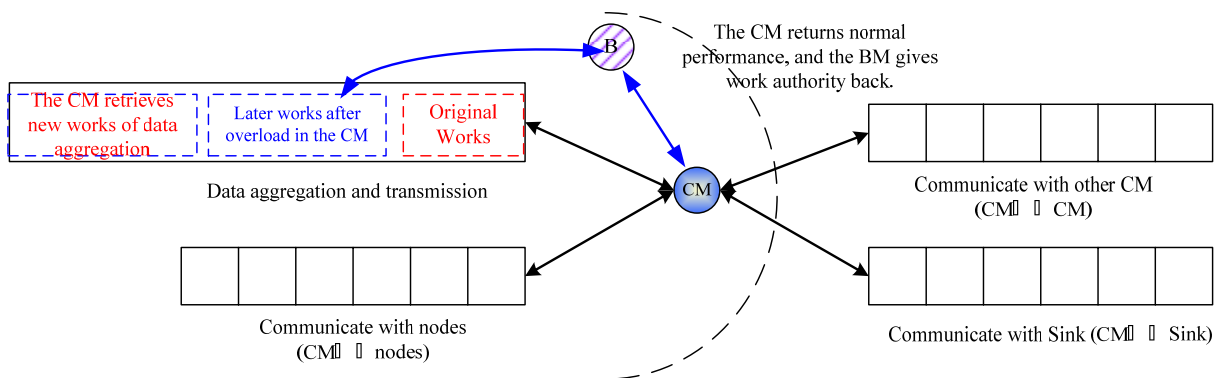

In our research, the threshold is a key point to decide when the BM is started. Therefore, according to three load factors to adjust the threshold timely is needed. However, the communication capability (c) and busy degree of processor (b) can both return when in normal performance. Nevertheless, the percentage of energy (e) will only be consumed constantly with time and practical applications. (Energy of SN is one-off that unable to recharge after SN is deployed.) Thus, the concept proposed in Allman, Paxson & Stevens (1999) is used to adjust the threshold (L_t)

elastically in terms of energy, it will reduce the weight of energy by 25% to adjust L_t . (The threshold is adjusted to 50% by traditional method, but we consider energy of SN is more limited. Therefore, every adjustment is only reduced 25 of percent.) For example, the weight of the original energy is 20%, after load judgment of CM, the weight of the energy becomes to 15%. The modified “New threshold of load capability function (L_t)” is given in formula (8).

$$\text{New } L_t = (e) * t_1 * 0.75 + (1/b) * t_2 + (c) * t_3 \tag{8}$$

In short, the “New threshold of load capability function (L_t)” is used to monitor the load capability of a CM and maintain the related works when the load capability of the CM reaches to low, and further, to keep stable of network topology.

The control flow of CM’s loading determination is shown in Figure 5. The procedure of CM’s loading determination is shown in Figure 6. By using the determination procedure, the BM can assist to process data aggregation of CM and the workload of the CM can be reduced. In addition, the loading of the CM returns to normal gradually. The time sequence of workload assigned between CM and BM is explained in Figure 7.

Figure 5: The control flow of CM’s loading determination.

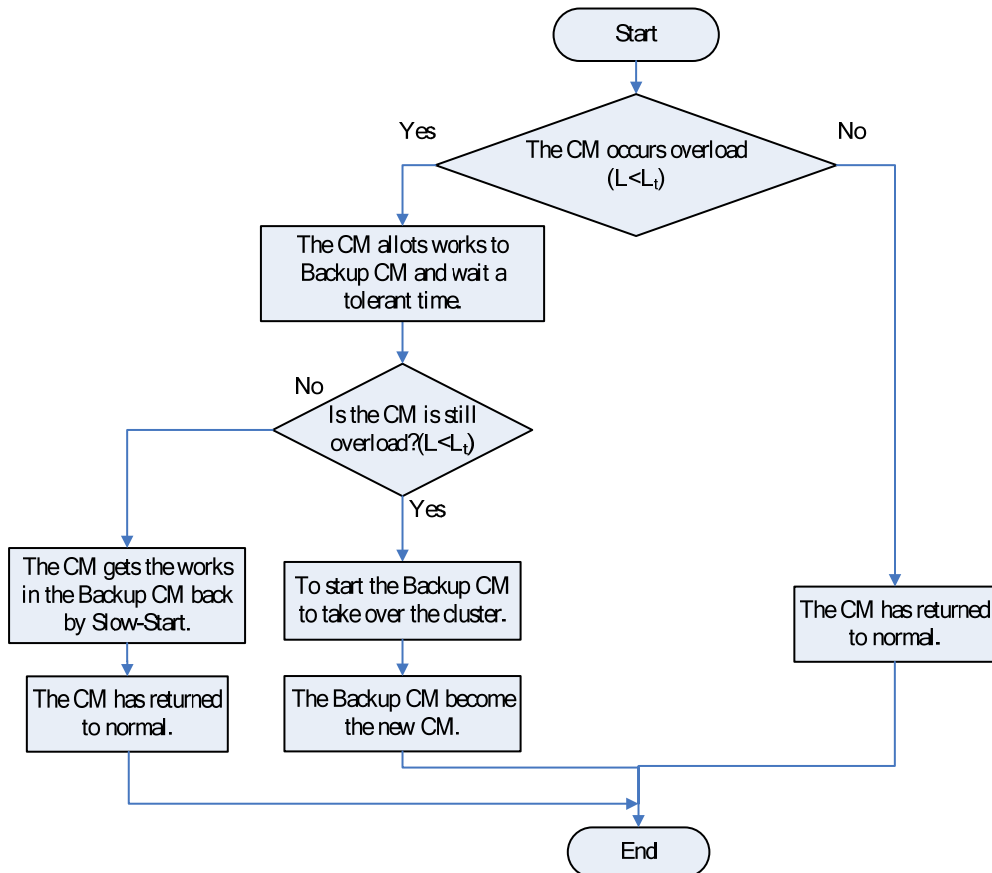

Figure 6: The procedure of CM’s loading determination.

```

FUNCTION CM_Load(Cj)

```



```

 $L_t = (e) * t_1 + (1/b) * t_2 + (c) * t_3$ ; //To compute the threshold of load capability
 $L = (e) * w_1 + (1/b) * w_2 + (c) * w_3$ ; //To compute load capability of the CM in the cluster j
IF L of the CM is less than  $L_t$ 
    Waiting for a tolerant time.
    IF L of the CM is less than  $L_t$ 
        The CM broadcasts "I am busy" message.
        The sensed data of SN is turned to the BM and SN requires services.
        The BM processes data aggregation of SN request.
        IF the CM returns to normal performance
             $L_t = (e) * t_1 * 0.75 + (1/b) * t_2 + (c) * t_3$  //To adjust the threshold of load capability.
            The CM broadcasts "I am ready" message.
            The BM finishes the present works and returns the aggregated data to original CM.
            The SNs communicate with the CM.
        END IF
    ELSE
        The CM is monitored continuously.
    END IF
ELSE
    The CM is monitored continuously.
END IF
END FUNCTION

```

Figure 7: The time sequence of workload assigned between CM and BM.

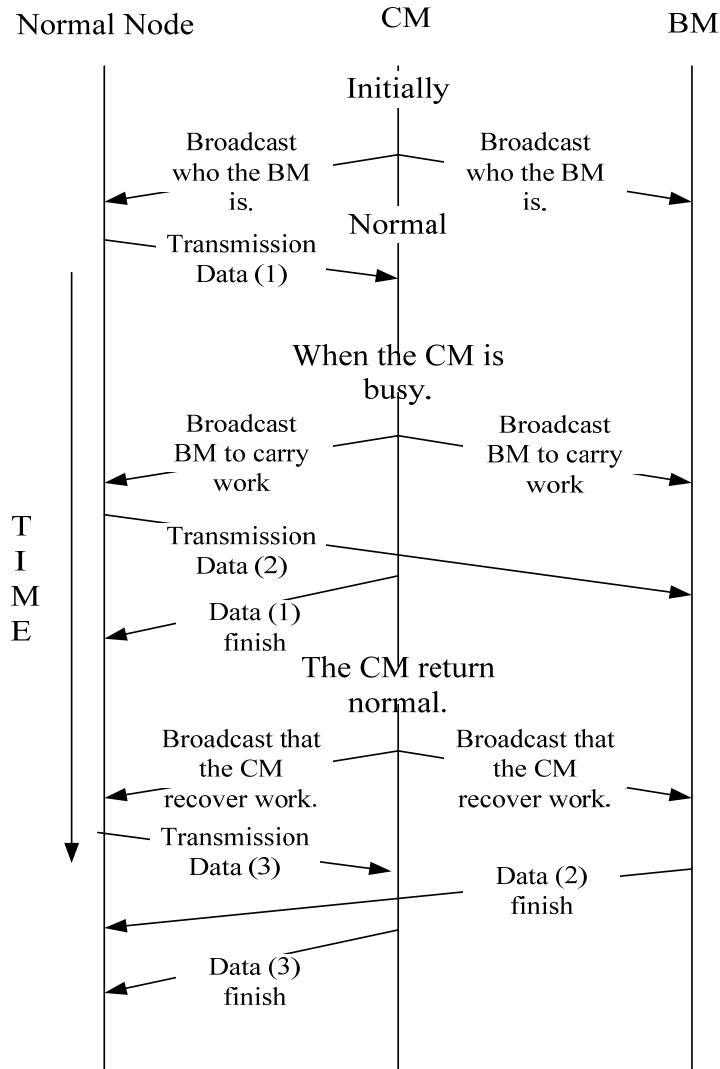

When the CM cannot still to provide service, the capability of BM will be estimated whether suit to take on the CM or not. If the capability of the BM is enough to take the CM, then the BM becomes a new CM, and the original CM needs to finish the present works in hand and becomes a normal SN. Nevertheless, if the capability of BM is also too low cannot to take on the new CM, then the cluster will dissolve and de-clustering. Due to de-clustering, a more stable WSN can be obtained.

CONCLUSION

There is an applicable treatment of relevant issue on WSN in this research. According to the researches in this field from the past scholars, their many methods on the election of manager and clustering in WSN did not consider the different stage of network, not develop the suitable method on the election of manager and clustering either, even failed to consider the reason why the manager is failed.

For these reasons, this research brings a treatment of the issue on the mechanism of election of manager and clustering. What is more, this research will also treat of the building of clustering and election of manager under multiple phase of network, of which covers the processing method of the initial, active and inactive phase in clustered-oriented WSN. Referring to the load capability, this research uses the percentage of energy (e), busy

degree of processor (b), and communication capability (c) as the basis of comparison.

In addition, the stability is very important especially in WSN, so the evacuated mechanism of CM's workload is proposed to assign the part of works to the BM to execute when the CM overload, and retrieve work authority of BM when the CM return normal performance for improving the stability and performance of WSN.

To summarize the main points that have been made in this paper, the proposed mechanism that the BM assists to process the workload of the CM by the concept of "slow-start" can balance the overload of a cluster. To achieve the goal that load balance, keeping a stable topology and prolong the lifetime of network.

REFERENCES

- Akkaya, K., & Younis, M., (2005, May). A Survey on Routing Protocols for Wireless Sensor Networks. *Elsevier Ad Hoc Network Journal*, 3, 325-349.
- Akyildiz, I. F., Weilian, S., Sankarasubramaniam, Y., & Cayirci, E., (2002). A Survey on Sensor Networks. *IEEE Communications Magazine*, 40 (8), 102-114.
- Allman, M., Paxson, V., & Stevens, W., (1999, Apr). RFC 2581: TCP congestion control.
- BA, (2006). <http://www.dustnetworks.com/applications/building.shtml>
- CM, (2003). <http://www.cqinc.com.tw/grandsoft/cm/116/atr-1.htm>
- Heinzelman, W.B., Chandrakasan, A.P., & Balakrishnan, H., (2002). An Application-Specific Protocol Architecture for Wireless Microsensor Networks. *IEEE Transactions on Wireless Communications*, 1 (4), 660-670.
- Indranil, G., Riordan, D., & Srinivas, S., (2005). Cluster-head Election using Fuzzy Logic for Wireless Sensor Networks. *Proceedings of the 3rd Annual Conference on Communication Networks and Services Research*, 255-260.
- Krishnan, R., & Starobinski, D., (2006, Jan). Efficient clustering algorithms for self-organizing wireless sensor networks. *Ad Hoc Networks*, 4 (1), 36-59.
- Laerhoven, K. V., Lo, B., & Ng, J., (2004). Medical Healthcare Monitoring with Wearable and Implantable Sensors. *The 3rd International Workshop on Ubiquitous Computing for Pervasive Healthcare Applications*.
- Lin, Y. Y., Su, Y. Y., Hwang, S. F., & Dow, C. R., (2005, Aug). A Cluster-Based Coverage-Preserving Scheduling Scheme for Wireless Sensor Networks. *Workshop on Wireless, Ad Hoc, and Sensor Networks (WASN 2005)*.
- Lindsey, S., & Raghavenda, C. S., (2002, Mar). PEGASIS: Power Efficient Gathering in Sensor Information Systems. *Proceedings of the IEEE Aerospace Conference*, Big Sky, Montana.
- Lo, B., Thiemjarus, S., King, R., & Yang, G., (2005). Body Sensor Network-A Wireless Sensor Platform for Pervasive Healthcare Monitoring. *The 3rd International Conference on Pervasive Computing*.
- Mhatre, V., Rosenberg, C., Kofman, D., Mazumdar, R., & Shroff, N. (2004). Design of Surveillance Sensor Grids with a Lifetime Constraint. *The First European Workshop on Wireless Sensor Networks (EWSN)*.
- Qing, L., Zhu, Q.X., & Wang, M. W., (2006, Aug). Design of a Distributed Energy-efficient Clustering Algorithm for Heterogeneous Wireless Sensor Networks. *Computer Communications*, 29 (12), 2230-2237.

- Shen, B., Zhang, S. Y., & Zhong, Y.P., (2006, Jul). Cluster-Based Routing Protocols for Wireless Sensor Networks. *Journal of Software*, 17 (7), 1588–1600.
- Wang, S. C., Yan, K. Q., & Tung, Y. P., (2007, Mar). The Framework for Cluster Manager Election and Clustering Mechanism in Mobile Sensor Networks. *Theme: From E-Commerce to Digital Life (EC DL2007)*, Shih Chien University, 1154-1167.
- Yan, K. Q., Wang, S. C., & Tung, Y. P., (2007). Efficient Load-Balance Clustering Mechanism for Wireless Sensor Network. *International Journal of Advanced Information Technologies (IJAIT)*.
- Younis, O. & Fahmy, S., (2004). HEED: A Hybrid, Energy-efficient, Distributed Clustering Approach for Ad Hoc Sensor Networks. *IEEE Transactions on Mobile Computing*, 3 (4), 660–669.

