

## CRACK INITIATION AND PROPAGATION RESISTANCE OF HSLA STEEL WELDED JOINT CONSTITUENTS

### OTPORNOST NA INICIJACIJU I RAST PRSLINE U KONSTITUENTIMA ZAVARENOG SPOJA NISKOLEGIRANOG ČELIKA POVIŠENE ČVRSTOĆE

Originalni naučni rad / Original scientific paper  
UDK /UDC:

Rad primljen / Paper received: 15.01.2020

Adresa autora / Author's address:

<sup>1</sup>) Faculty of Technical Sciences, Kosovska Mitrovica, Serbia

<sup>2</sup>) University of Belgrade, Innovation Centre of the Faculty of Mechanical Engineering, Belgrade, Serbia

<sup>3</sup>) University of Belgrade, Faculty of Mech. Engineering, Belgrade, Serbia, email: [asedmak@mas.bg.ac.rs](mailto:asedmak@mas.bg.ac.rs)

#### Keywords

- welded joint
- fracture toughness
- impact energy
- crack initiation energy
- crack propagation energy

#### Abstract

The welded joint is heterogeneous in its microstructure, mechanical and geometrical properties, thus the stress field is affected by different factors as well as by residual stress. Therefore, special procedures are needed for experimentally determining the fracture toughness in plane strain,  $K_{Ic}$ , and the impact toughness, usually associated with difficulties in interpreting the measured values. Notched specimens are tested by instrumented Charpy in order to determine impact energy and crack initiation and propagation energies. The pre-cracked specimens are tested by standard, using three-point bending specimens, as geometrically closest to Charpy specimens. In both cases, the notch and crack are located in all various regions of the welded joint of the high-strength low alloyed steel NIONIKRAL-70. Analysis of the results includes speculations on the ratio of energies for crack initiation and propagation vs. fracture toughness.

#### INTRODUCTION

Nionikral-70 is chosen as a typical representative of high strength low alloyed (HSLA) steels with complex microstructure and significant differences in mechanical properties and resistance to crack initiation and propagation. Nionikral-70 used in this research is produced by 'ACRONI-Slovenske Železarne' Jesenice (Slovenia) in an electric

#### Ključne reči

- zavareni spoj
- žilavost loma
- energija udara
- energija nastanka prsline
- energija rasta prsline

#### Izvod

Zavareni spojevi su heterogeni u smislu mikrostruktura i mehaničkih osobina, kao i u pogledu geometrije i raspodele napona na koje utiči razni faktori, poput zaostalnih napona. Stoga, neophodni su posebni postupci za eksperimentalno određivanje žilavosti loma pri ravnom stanju deformacije,  $K_{Ic}$ , kao i energije udara, koji su obično praćeni teškoćama pri tumačenju izmerenih rezultata. Epruvete sa zarezima su ispitane na instrumentiranom Šarpijevom klatnu kako bi se odredile energija udara, kao i energija nastanka i energija rasta prsline. Epruvete sa prslinom su ispitane na standardni način, savijanjem u tri tačke, što je geometrijski gledano najbliže Šarpijevim epruvetama. U oba slučaja, zarez i prsline su postavljeni u različitim oblastima zavarenog spoja niskolegiranog čelika povišene čvrstoće NIONIKRAL-70. Analiza rezultata obuhvatila je spekulacije o odnosu energije nastanka i energije rasta prsline i žilavosti loma.

furnace, casted into blooms, and flat rolled to 18 mm thick slabs. Strengthening is achieved by quenching and tempering, followed by grain refinement, as given in Table 1, /1/. The Tenacito-75, basic coated, low hydrogen electrode of 3.25 and 4 mm diameter, is used for manual metal arc butt welding in the 2/3 X-groove. The Chemical composition and mechanical properties are shown in Table 2, /1/.

Table 1. Mechanical properties and chemical composition of Nionikral-70 steel.

Batch	Testing direction	Min. yield strength $R_{p0.2}$ (MPa)		Min. tensile strength, $R_m$ (MPa)		Dilatation $\epsilon$ (%)			
180079	L - T	710		770		14			
Chemical composition (% mass)									
C	Si	Mn	P	S	Cr	Ni	Mo	V	Al
0.10	0.20	0.23	0.009	0.018	1.24	3.10	0.29	0.05	0.08

Table 2. Mechanical properties and chemical composition of Tenacito-75 electrode.

Electrode	Min. yield strength $R_{p0.2}$ (MPa)	Min. tensile strength $R_m$ (MPa)	Dilatation $\epsilon$ (%)	Impact energy (J)		
				-20°C	-40°C	-60°C
Tenacito-75	725	780	12	110-140	65-95	50-80
Chemical composition (% mass)						
C	Mn	Si	Cr	Ni	Mo	
0.06	1.45	0.25	0.55	2.0	0.35	

DETERMINATION OF FRACTURE TOUGHNESS,  $K_{Ic}$

The original standard for fracture toughness testing,  $K_{Ic}$ , assumes plane strain conditions, /2/, in order to ensure that the plastic deformation occurs only in a negligible small area around the crack tip prior to crack propagation and fracture. Since a majority of structural materials and welded joints behaves such that a large area of plastic deformation forms around the crack tip, a direct determination of  $K_{Ic}$  is practically impossible. Therefore, to overcome these limitations, elastic-plastic fracture mechanics needs to be involved, either by crack tip opening displacement CTOD ( $\delta$ ), or by J integral. Here, the critical value of the J integral,  $J_{Ic}$ , and its correlation with  $K_{Ic}$  are employed:

$$J_{Ic} = \frac{(1-\nu^2)K_{Ic}^2}{E}, \tag{1}$$

where:  $E$  is the elasticity modulus;  $\nu$  - Poisson's coefficient.

Fracture mechanics testing of specimens extracted from welded plates is done on three point bending specimens (SEB), Fig. 1, according to ASTM E399, /2/. Tests are performed with the SCHENCK TREBEL RM 100 electro-mechanical testing machine. The crack tip opening is measured by special extensometer CLIP-GAGE DD1, with a measuring accuracy of  $\pm 0.001$  mm.

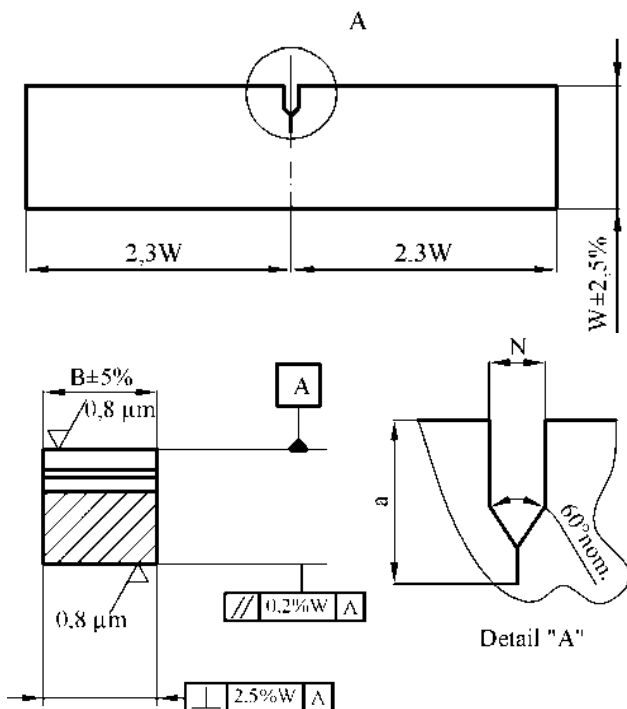

Figure 1. Fracture mechanics test specimen.

Fracture toughness,  $K_{Ic}$ , is determined using the critical value of J integral,  $J_{Ic}$ , by applying the procedure according to ASTM E813-89, /3/. All necessary details and results are given in /4-6/, including the location of the crack in different regions of welded joint, whereas the values of fracture toughness are given in Table 3.

Table 3. Fracture mechanics parameters  $J_{Ic}$  and  $K_{Ic}$ .

Specimen	Critical J integral $J_{Ic}$ (kJ/m <sup>2</sup> )	Fracture toughness $K_{Ic}$ (MPa m <sup>1/2</sup> )
BM-1, 20°C	90.4	142.7
BM-2, 20°C	94.3	145.8
BM mean		144
WM-1, 20°C	64.3	119.2
WM-2, 20°C	61.5	116.6
WM mean		118
HAZ-1, 20°C	80.4	131.9
HAZ-2, 20°C	74.9	127.3
HAZ mean		129.5

IMPACT TESTING

Impact tests of Charpy specimens with notches in base metal, weld metal and the heat affected zone are performed in order to determine the total impact energy and its components - crack initiation and propagation energy. The test procedure and specimen sizes and shape, as shown in Fig. 2, are defined according to SRPS EN 10045-1 EN, /7/, and SRPS EN 10045-2, /8/, or ASTM E23-02, /9/.

The notch is positioned according to EN 875, /10/. All relevant details and results are given in /11/, whereas the impact test results for specimens with the notch in BM are given in Table 4, and for specimens with notch in WM in Table 5, and in Table 6 for specimens with notch in HAZ.

Table 4. Impact test results for specimen with notch in BM.

Specimen	Impact total energy, $A_T$ (J)	Crack initiation energy, $A_I$ (J)	Crack propagation energy, $A_P$ (J)
BM-1a, 20°C	118	43	75
BM-2a, 20°C	126	49	77
BM-3a, 20°C	131	50	81
BM average	125	47	78

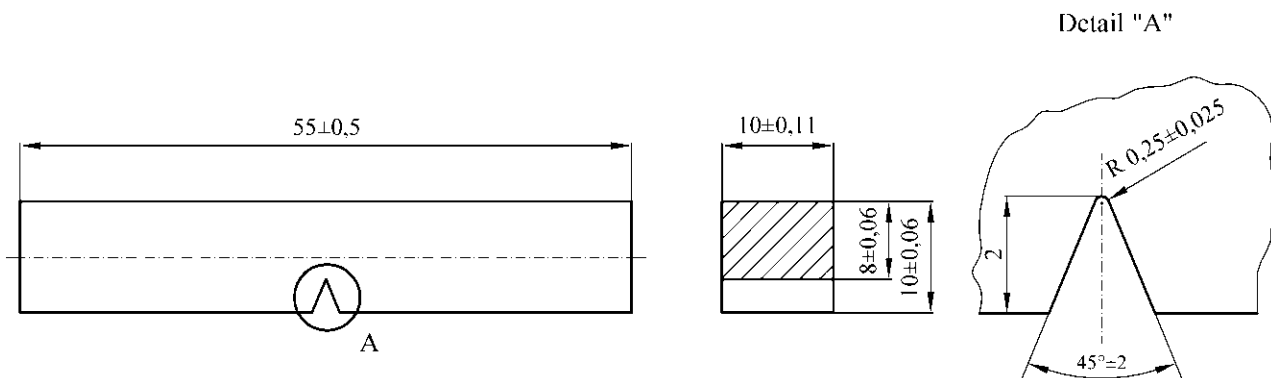

Figure 2. Impact energy test specimen.

Finally, the ratio between crack initiation and propagation energies and fracture toughness is analysed, as done previously for welded joints made of steel A-387 Gr. B, /6/. This analysis is only speculative since Charpy impact and fracture mechanics tests are essentially different (static vs. dynamic loading, notch vs. crack), but it helps in better understanding of the heterogeneous material resistance to crack initiation and propagation.

It has already been done in /6/, thus indicating a linear relation between crack initiation energy and fracture toughness (0.41-0.58, or even better, 0.43-0.5, if extreme values are not taken into account), as shown in Table 7, /6/. One can also see that no such relation exists for energy components  $A_P$  and  $A_T$ .

Analogous results for Nionikral-70 are given in Table 8 (based on average values), indicating practically the same, but only for the BM and HAZ, and not for the WM.

Table 5. Impact test results for specimen with notch in WM.

Specimen	Total impact energy, $A_T$ (J)	Crack initiation energy, $A_I$ (J)	Crack propagation energy, $A_P$ (J)
WM-1a, 20°C	47	17	30
WM-2a, 20°C	40	12	28
WM-3a, 20°C	43	19	24
WM average	43	16	27

Table 6. Results for specimens with notch in HAZ, tested at 20°C.

Specimen	Impact total energy, $A_T$ , J	Crack initiation energy, $A_I$ , J	Crack propagation energy, $A_P$ , J
HAZ-1a	129	45	84
HAZ-2,a	124	41	83
HAZ-3a	119	39	80
HAZ mean	124	42	82

Table 7. Impact energy test results, combined with fracture toughness, A-387 Gr. B.

	$A_T$ (J)	$A_I$ (J)	$A_P$ (J)	$K_{Ic}$ (MPa m <sup>1/2</sup> )	$A_T/K_{Ic}$	$A_I/K_{Ic}$	$A_P/K_{Ic}$
New BM, 20°C	210	48	162	118	1.78	0.41	1.37
New BM, 540°C	140	40	100	88	1.59	0.45	1.14
Old BM, 20°C	96	46	50	100	0.96	0.46	0.5
Old BM, 540°C	78	32	46	64	1.22	0.5	0.72
New WM, 20°C	190	60	130	131	1.45	0.46	0.99
New WM, 540°C	136	40	96	94	1.45	0.43	1.02
New HAZ, 20°C	185	45	140	101	1.83	0.45	1.39
New HAZ, 540°C	135	45	90	78	1.73	0.58	1.15
Old HAZ, 20°C	90	42	48	93	0.97	0.45	0.52
Old HAZ, 540°C	75	30	45	61	1.23	0.49	0.74

Table 8. Impact energy test results, combined with fracture toughness, Nionikral-70.

	$A_T$ (J)	$A_I$ (J)	$A_P$ (J)	$K_{Ic}$ (MPa m <sup>1/2</sup> )	$A_T/K_{Ic}$	$A_I/K_{Ic}$	$A_P/K_{Ic}$
BM, 20°C	125	47	78	144	0.87	0.33	0.54
WM, 20°C	43	16	27	118	0.37	0.14	0.23
HAZ, 20°C	124	42	82	129.5	0.96	0.32	0.63

## CONCLUSIONS

Heterogeneity of crack resistance properties in Nionikral -70 welded joint is mostly expressed for Charpy energy, both initiation,  $A_I$ , and propagation,  $A_P$ , being significantly lower for the WM (16 vs. 42-47 for  $A_I$ , 27 vs. 78-82 for  $A_P$ ) than for the fracture toughness,  $K_{Ic}$ , with differences in the range of 10 % (118-144, i.e.  $131 \pm 13 \text{ MPa}\sqrt{\text{m}}$  compared to the minimal and maximal value, /1/. Therefore, it is obvious that a different microstructure in different regions of the welded joint affects crack resistance more in dynamic than in static loading conditions.

From the point of view of material resistance to crack initiation and propagation, one concludes that both are significantly affected by welded joint heterogeneity, also affecting the linear relation between the crack initiation energy and fracture toughness, which otherwise holds for steel A-387 Gr. B.

Although purely speculative, this relation indicates the same level of crack resistance for two different types of loading, regardless of crack existence. As expected, the material behaviour is different for the crack propagation energy and fracture toughness since these two properties differ only in the loading type, but interestingly enough for most of the microstructures, it seems that crack existence nullifies the effect of the dynamic loading.

## ACKNOWLEDGEMENTS

Parts of this research are supported by the Ministry of Education, Science and Technological Development of the Republic of Serbia through Mathematical Institute SANU Belgrade project OI 174001 'Dynamics of hybrid systems with complex structures. Mechanics of materials' and the University of Priština, Faculty of Technical Sciences, allocated in Kosovska Mitrovica.

## REFERENCES

1. Čamagić, I. (2009), Analiza napona i deformacija zavarenih spojeva niskolegiranih čelika povišene čvrstoće u prisustvu prslina, Magister Thesis (*Stress and strain analysis of welded joints of HSLA steels having cracks*, in Serbian), University of Priština, Faculty of Technical Sciences at Kosovska Mitrovica, Serbia.
2. ASTM E399-89, Standard Test Method for Plane-Strain Fracture Toughness of Metallic Materials, Annual Book of ASTM Standards, Vol. 03.01., 1986, p. 522.
3. ASTM E813-89, Standard Test Method for  $J_{Ic}$ , A Measure of Fracture Toughness, Annual Book of ASTM Standards, Vol. 03.01., 1993, p. 651.
4. Čamagić, I., Burzić, Z., Sedmak, A., et al. (2014), *Influence of mechanical properties and microstructural heterogeneity of welded joint constituents on tensile properties and fracture toughness at plane strain,  $K_{Ic}$* . Struct. Integrity and Life, 14(1): 45-49.
5. Čamagić, I., Sedmak, S.A., Sedmak, A., et al. (2017), *Impact of temperature and exploitation time on plane strain fracture toughness,  $K_{Ic}$ , in a welded joint*, Struct. Integ. and Life, 17(3): 239-244.
6. Čamagić, I., Sedmak, A., Sedmak, S.A., Burzić, Z. (2019), *Relation between impact and fracture toughness of A-387 Gr. B welded joint*, Procedia Structural Integrity, 18: 903-907. doi: 10.1016/j.prostr.2019.08.241.
7. SRPS EN 10045-1, Mehanička ispitivanja metala - ispitivanje udarom po Šarpiju, Deo 1: Metoda ispitivanja, 1993.
8. SRPS EN 10045-2, Mehanička ispitivanja metala - ispitivanje udarom po Šarpiju, Deo 2: Verifikacija uređaja za ispitivanje, 1993.
9. ASTM E 23-02, Standard Test Methods for Notched Bar Impact Testing of Metallic Materials, Annual Book of ASTM Standards, Vol. 03.01, 2002.
10. EN 875, Destructive tests on welds in metallic materials - Impact tests - Test specimen location, notch orientation and examination, 1995.
11. Čamagić, I., Jović, S., Radojković, M., et al. (2016), *Influence of temperature and exploitation period on the behaviour of a welded joint subjected to impact loading*, Struct. Integ. and Life, 16(3): 179-185.

© 2019 The Author. Structural Integrity and Life, Published by DIVK (The Society for Structural Integrity and Life 'Prof. Dr Stojan Sedmak') (<http://divk.inovacionicentar.rs/ivk/home.html>). This is an open access article distributed under the terms and conditions of the [Creative Commons Attribution-NonCommercial-NoDerivatives 4.0 International License](https://creativecommons.org/licenses/by-nc-nd/4.0/)