

AN INCREASE OF HYDRO-AGGREGATE'S INSTALLED POWER AND EFFICIENCY FACTOR BEFORE THE REVITALIZATION PHASE

by

***Dragan PETROVIĆ, Veljko VIDA KOVIĆ, Zoran ĆIRIĆ,
Siniša STOJKOVIĆ, Miroslav BENIŠEK, Ivan BOŽIĆ,
Milorad DRAGIĆ, and Milorad ZELJIĆ***

Original scientific paper

UDC: 621.221

BIBLID: 0354-9836, 10 (2006), Suppl., 4, 17-32

The revitalization of hydro-aggregates should be performed before the life-time expiry of most their parts. But, as in our practice aggregates have been under exploitation much longer than theoretical life-time advices (40, even 50 years), there is a need to estimate the equipment's condition through more sophisticated monitoring, providing the maximum level of safety and availability with minimum investment expenses, before the revitalization finally takes place. That estimation is based on appropriating calculations and measurements needed to take the competent decision. Results of that analysis can be also useful for estimation of the aggregate's power and parameters after the revitalization.

In this paper the results of appropriate calculations and measurements for the Hydropower station HE Zvornik are given.

Key words: *hydro-aggregates, power increasing, calculations, measurements, efficiency increasing*

Introduction

Most of hydro-aggregates in hydro power plants belonging to the electro energetic system of Serbia have are operating on the edge or beyond the projected life-time. Those old hydro-aggregates are still relatively reliably functioning only because of harder maintenance and non-standard technical solution during regular repairs.

The experts from "Electric Power Industry of Serbia" (EPS), being aware of the fact that this *modus operandi* cannot last forever and that resources recycling is more economically efficient than exploitation on the edge of reliability, are planning the most urgent revitalizations already few years ago.

The term of the revitalization of the old hydro-aggregates, besides recycling their reliability of future operation for at least 30 years, also regards their modernization and performance increasing. That is the reason why, during revitalization planning, possibility of a power increase always becomes an issue.

Besides that, as during operation many parts of hydro-aggregates have been significantly changed (replaced windings, excitation system, measurement's equipment, *etc.*), being also over dimensioned by initial project, a logical urge for examining possibilities for exploiting hydro-aggregates beyond their projected boundaries raises, making possible their more rational use before the revitalization starts. Of course that kind of decision should not affect the reliability of appropriate parts of the aggregate.

During many years of exploitation, interventions affecting power increasing were already undertaken on certain hydro-aggregates even before the revitalization. For instance, replacing windings with B class isolation with windings with F class isolations enables greater level of permitted temperature increasing. Further, replacement of excitation system, cooling system, *etc.*, also contribute to more efficient exploitation of present aggregates. Some hydro-aggregates, for instance HE Djerdap 2, were over dimensioned by initial construction, so it is a waste not to use all their possibilities.

The Faculty of Electrical Engineering from Belgrade conducted many studies which EPS ordered with mostly same focus – analysis of hydro-aggregate's power increasing possibility through revitalization. Hydro-aggregates of various types and rated powers were analyzed, operating in power utilities in the system of Djerdap HE, one from the system of Limske HE and two from the system of Drinske HE (HE – hydroelectric power station).

The calculations and analysis proved that in the case of 5 from 6 analyzed generators, with no major investments, power increasing factor of 10-15% was possible. One of them, with newer production date, proved not to have such a reserve.

Besides possibilities for power increasing of the generators, condition and capacity of the turbine should also be checked. The turbine is, in some cases, limiting factor to explore all possibilities of the generator. In the phase before revitalization of the aggregates with Kaplan's turbine it is possible to inspect if connection is tuned enough through finding optimal parameters combination in order to use the connection more effectively. This kind of examination was not conducted on most of the hydro-aggregates in Serbia.

The power increase activities undertaken in the HE Zvornik

Data sheets about the aggregates in HE Zvornik

Hydro power plant in Mali Zvornik belongs to the oldest ones in Serbia. Four hydro-aggregates with 24 MW generators were put in the operation in the period between years 1955 and 1958. The production with average of 6400 working hours per year exceeded about 22 billions kWh of electrical energy. Manufacturer of the generator is "Rade Končar" Zagreb, Croatia, and of the turbines VOITH.

That amount of so many years of intensive exploitation was achieved mainly due to regular maintenance, but also thanks to certain interventions such as the investment in replacement of the stator winding with new one with higher level of isolation class (F instead of B) which was done between year 1970 and 1980, and also implementation of the new thyristor excitation system.

During the exploitation, the thermal condition of windings, magnetic circuit, cooling air, and bearings was under permitted limits, so it was obvious that, in that sense, the generators could operate with greater power. Regarding the turbines, no reliable facts were present about their exploitation possibilities, which should be also checked. Every year, inside the system of Drinske HE to which HE Zvornik belongs, the water overflowing occurs, which could be transformed into significant amount of produced electrical energy. That means a better efficiency factor of use of the hydro energetic potential of the Drina River, *i. e.* of HE Zvornik also.

Regarding this fact, the HE Zvornik's management and the experts have initiated the Study [1], which through calculations and measurements proved the possibility of an power increase of up to 10% regarding only the existing generator's condition. The results of the calculations were verified with appropriate measurements [2]. During the measurements with increased active power with nominal power factor the temperatures of the stator's magnetic circuit, stator' and rotor's windings, flow and temperature of cooling air and water were controlled. The certain generator's losses were calculated with calorimetric method, as no reliable data existed before. Calculated data were then compared with measured ones. Such detailed level of examination is needed in order to reliably estimate the possible thermal reserve and efficiency factor of the generator. To find out the optimal efficiency factor, the planned experimental tuning of the combined aggregate-turbine connection must be performed. In that way, possibilities of the turbine, besides the generator, will be also known, leading to completing the whole project.

Methodology of the generator's possibilities calculation

Each generator has been constructed based on his mechanical, electromagnetic, and thermal calculations, in order to achieve operation with nominal power and nominal power factor without mechanical, electric or thermal overload. During that nominal operation mode (regime) stator and rotor currents will exceed maximum of their nominal values, and temperature raises of active parts will be inside permitted limits for defined class of isolation. When a working point of the generators is not inside the nominal parameters area, of the stator current or the rotor current or both at the same time increases, which further results in increasing the temperature raises of active parts.

As a part of the mentioned Study [1] the three specific regimes of operation were analyzed: two with overload of 5% and 10% of nominal power with nominal power factor (0,8) and one regime with increased active power of 5% and decreased power factor. For each regime the stator and rotor currents, power losses and efficiency factor, temperature raises of active parts and cooling air and the electromagnetic torque were calculated. After that, according to the results, conclusion about possibility of power increasing and eventual limitations which should be eliminated during the revitalization was made.

Excitation current calculation [1]

Excitation current calculation in regimes other than nominal can be conducted with any of graphic-analytic methods; Potier's method being the most suitable. For that cal-

ulation characteristics of no load and short-circuit are needed, as well as the V-curve characteristic when active power equals zero under the rated voltage. Vector addition of the two components of magnetomotive force, the one which compensates direct induct's reaction and the other which represents the mutual inducted electromotive force, results in total magnetomotive force, proportional and to exciting current. The same algorithm is repeated for the every over load regime. Exciting current's values are then readable from the V-curve characteristic and the characteristic of short-circuit and are representing inputs for further graphical estimating and calculating: the construction of the Potier's triangle, computing of Potier's leakage reactance, computing the amplitude and argument of mutual electromotive force, reading out the components of the exciting current from the V-curve characteristic and the characteristics of short-circuit and finally their vector addition.

The method is precise as much as the three named characteristics are precisely constructed. The most complicated is the V-curve characteristic because of deviation of the voltage from its nominal value. The correction of V-curve characteristic because of named deviations is possible, and it was done once when the deviation was drastically present. Beside that, to estimate the excitation current more precisely, the extrapolation of the V-curve characteristic must be done also (which is not problematic because it is almost linear in that area).

From the precision aspect, it is far more convenient if characteristics are given tabular because then it is possible to apply numerical methods (such as the least square error) and so construct the representative graphical presentation.

To analyze precision of the calculation, beside the exciting currents in the regimes of overload the same method is applied on the calculation on the exciting current in the nominal regime. Comparing results with declared and/or measured value of the excitation current in nominal regime gives the total calculation of the error (in percentage). As the calculated excitation current in nominal regime was less then nominal excitation current for 0,9%, the same correction factor was applied on the excitation current in overload regime. That corrected value was input for further calculations and analyses (calculation of losses on excitation and in excitation system and analyze of possibility of the excitation system to provide excitation current in overload regime).

The excitation currents (I_f) computed for all of the analyzed regimes are given in tab. 1.

Table 1. Results of the excitation current calculation

No.	S/S_n	P/P_n	$\cos\varphi$	I [A]	$I_{f\text{calc}}$ [A]	$I_{f\text{corr}}$ [A]
1	1.00	1.00	0.8	1575	624.5	630.0
2	1.05	1.05	0.8	1654	642.1	647.7
3	1.10	1.10	0.8	1732	659.1	664.8
4	1.10	1.05	0.764	1732	670.5	676.3

Calculation of losses [1]

Knowing the values of the particular losses in the nominal regime of operation, it is easy to estimate their values in the overload regime also. Losses on ventilation, losses on bearings and hysteresis and eddy current core losses are considered to be constant and are not recalculated for the new regime. Basic and additional copper losses have been recalculated from the nominal regime to the regime with increased power by multiplying their values with the square of the relative value of the stator current, while the losses on the excitation are multiplied with the square of the relative value of the rotor current. The losses in the excitation system also depend from the rotor current with difference that losses in thyristors and on brushes are proportional to first degree, and in exciter and in excitation transformer with second degree of the current's relative value.

For the generators which belong to HE Zvornik there were no data of the particular losses known, except of the efficiency factor in the nominal regime which equals 96,7%. Based on that parameter, the total losses P_γ in the generator are evaluated as follows:

$$P_\gamma = \frac{100P_n}{\eta} - \frac{\eta P_n}{96.7} = \frac{100 \cdot 24000}{96.7} - \frac{96.7 \cdot 24000}{96.7} = 819 \text{ kW} \quad (1)$$

In order to estimate the thermal condition of the generator for each regime of operation, calculation of all of the particular losses is essential. The calculation was conducted according to Russian sources [3]. Inputs for the calculations are data about the windings, dimensions of all parts in details, values of iron losses of insulation laminations, values of the rotor, stator and exciter resistance, bearings and cooling system parameters, *etc.*. The particular losses consist of:

- Constant losses – ventilation losses, bearings losses, magnetic losses in stator core, magnetic losses in teethes, losses in end packages due to axial leakage flux, and losses in pole pieces as a consequence of the stator teething.
- Losses which depend of stator current – Joule's losses in stator copper, additional stator copper losses due to skin effect, losses in teethes due to third harmonic of stator's magnetomotive force (MMF), losses in pole pieces due to higher order harmonics of stator's magnetomotive force, losses in pole pieces due to stator's field with teeth's frequency, and losses in squeezing plates due to leakage flux from currents through the end parts of windings.
- Losses which depend of rotor current – losses in rotor copper, excitation system losses, and losses on brushes.

All of mentioned losses, evaluated for the nominal regime of operation, are to be recalculated for overload regime on the same way as measured losses.

Efficiency factor calculation for any overload regime is based on total losses.

In tab. 2. results of calculations of particular losses in generators of HE Zvornik are shown, for nominal and also for overload regimes.

All particular losses are evaluated according to [1] and [3], ventilation losses are evaluated as a difference between total losses P_γ and all other calculates particular losses.

Table 2. Particular losses and efficiency factor

No.	Description	Power			
		P_n $\cos\varphi = 0.8$	$1.05 P_n$ $\cos\varphi = 0.8$	$1.1 P_n$ $\cos\varphi = 0.8$	$1.05 P_n$ $\cos\varphi = 0.907$
1	Losses in stator core, P_a [kW]	60.2	60.2	60.2	60.2
2	Losses in stator teethes, P_z [kW]	68.3	68.3	68.3	68.3
3	Additional magnetic losses, P_{po} [kW]	22.4	22.4	22.4	22.4
4	Losses in end packages of stator teethes, P_{zkr} [kW]	12.2	12.2	12.2	12.2
5	Ventilation losses in rotor zone, P_{vr} [kW]	66	66	66	66
6	Ventilation losses in stator zone, P_{vs} [kW]	131.9	131.9	131.9	131.9
7	Bearing losses, [kW]	46.6	46.6	46.6	46.6
8	Stator current, I [A]	1575	1654	1732.5	1732.5
9	Losses in stator copper, P_{Cu} [kW]	162.2	178.8	196.3	196.3
10	Additional losses in stator copper, P_f [kW]	24.4	26.9	29.5	29.5
11	Losses due to 3 rd MMF harmonic, P_{3h} [kW]	67.9	74.8	82.1	82.1
12	Losses due to MMF higher harmonic, P_{ph} [kW]	7.6	8.4	9.2	9.2
13	Losses due to teethe field shape, P_{pz} [kW]	4.8	5.3	5.8	5.8
14	Losses in squeezing plates, P_{ed} [kW]	15.3	16.9	18.5	18.5
15	Rotor current, I_f [A]	630	647.7	664.8	676.3
16	Losses in rotor copper, P_f [kW]	116	122.6	129.2	133.6
17	Losses in exciter, P_B [kW]	10.7	11.3	11.9	12.3
18	Losses on brushes, P_c [kW]	2.5	2.6	2.6	2.7
19	Total losses, ΣP_γ [kW]	819	855.2	892.7	897.6
20	Generator real power, P [kW]	24000	25200	26400	25200
21	Efficiency factor $\eta = P/(P + P_\gamma)100$ [%]	96.70	96.72	96.73	96.56

Thermal calculation

Calculation of temperature raises of specific active parts of the generator is a key point of a power increase possibility analysis. Method of calculation is based on the concentration of before mentioned losses, regarding to their origin, in stator core, teethes of stator core, in winding copper of stator, in winding copper of rotor, and in pole pieces, following their flow from there to surface of a machine. The calculation is conducted separately for stator and rotor and the only mutual parameter is over temperature of cooling air.

Power flows P and the increase of the temperature $\Delta\theta$ in certain parts of stator are evaluated according to scheme shown on fig. 1. [1].

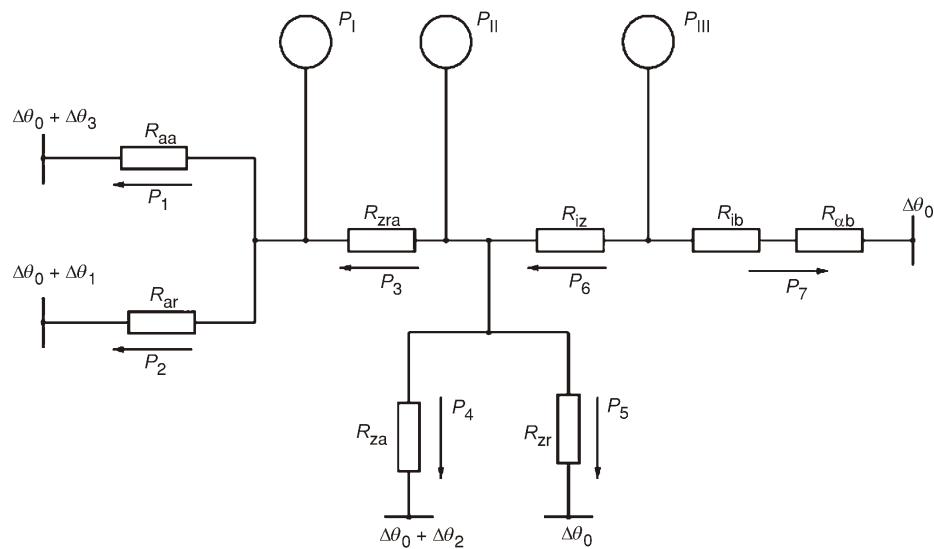

Figure 1. Thermal scheme of stator

Particular thermal resistances R are evaluated based on the length and the area of the material the heat flows through and based on the area which through the heat is being convected as well as on coefficients of conduction and/or convection. They are:

- R_{aa} – combined resistance to the heat transfer through the yoke packages in axial direction and its convection into the channels,
- R_{ar} – convection resistance from the core outer surface into the space ahead to the cooler,
- R_{zra} – resistance to the heat transfer from the teeth into the yoke in an axial direction,
- R_{za} – combined resistance to the heat transfer through teeth packages in axial direction and its convection into the channels,
- R_{zr} – resistance from the core inner surface into the air-gap,

- R_{iz} – resistance to the heat transfer through the isolation in the slot part of the bars,
 R_{ib} – resistance to the heat transfer through the isolation in the end part of windings,
 and
 R_{ab} – convection resistance from the bars in the end part of windings.
 Powers P_I , P_{II} , and P_{III} represent the losses in the yoke, the teethes and the stator copper.

The increases of cooling air temperature along the cooling part are:

- $\Delta\theta_0$ – the air-gap,
 $\Delta\theta_1$ – from the air-gap to the cooler inlet,
 $\Delta\theta_2$ – from the air-gap to the teeth's middle, and
 $\Delta\theta_3$ – from the air-gap to the yoke's middle.

An increase of temperature in the air-gap compared to the temperature of the input air $\Delta\theta_0$ is directly proportional to the sum of rotor zone losses and part of stator losses related to the air-gap, and inversely proportional to total losses which are heating the air. The total increase of air's temperature in a generator is proportional to total losses which are heating an air. Considering an increase of temperature along the ventilation channel to be linear, temperature raises $\Delta\theta_2$ and $\Delta\theta_3$ are evaluated.

Losses of power in particular branches in the thermal scheme (P_1 to P_7) are calculated on the same way as currents in analog electrical circuit. In order to transform the circuit, a temporary assumptions must be made that the ends of the circuit are closed with over temperature $\Delta\theta_0$, *i. e.* that there are no increase of air temperature along the ventilation channels. At first the partial power flows are calculated assuming that the source is only P_I , then only P_{II} , and at last only P_{III} , and after that the results are summarized. With so calculated powers air's temperature raises are evaluated in specific points along the ventilation channels. Due to assumptions made, losses of power in particular branch are only approximate, so appropriate corrections of the resistances in output branches in which the increase of air temperature along the ventilation channels was neglected. That correction is performed by putting temporary additional resistances in such branches, which values multiplied with power in the branch, equals neglected increase of air temperature. For instance $R_{aa\ add} = \Delta\theta_3/P_1$ *etc.* Power flow and air temperature raises are then calculated again with the new additional resistances, and the method is applied again until the results start to converge, usually after a few iterations giving precise values of powers in particular branches.

Temperature raises of specific active parts of the generator are evaluated by adding the temperature drops on thermal resistances onto air temperature raise in specific points of cooling system, until reaching the referred point. So, for instance, temperature raise of the yoke is calculated as $\Delta\theta_a = \Delta\theta_0 + \Delta\theta_3 + R_{aa}P_1$.

Results of calculation of the air temperature raises $\Delta\theta_0$, $\Delta\theta_1$, θ_2 , and $\Delta\theta_3$, the yoke $\Delta\theta_a$, the teethes $\Delta\theta_z$, the stator winding $\Delta\theta_{Cu\ s}$ and the rotor winding $\Delta\theta_{Cu\ r}$ are given in tab. 3 for all off the regimes.

Calculated temperature raises of a stator $\Delta\theta_{Cu}$, given in tab. 3, represent the difference between copper coils in the bar and cooling air on the generator's inlet. In order to compare those values with referring ones, the amount which equals temperature drops on the bar isolation, housing of the thermometer and joint between them must be subtracted.

Table 3. Results of calculation of temperature raises

No.	Regime	Temperature raise [°C]							
		Air				Iron		Copper	
		$\Delta\theta_0$	$\Delta\theta_1$	$\Delta\theta_2$	$\Delta\theta_3$	$\Delta\theta_a$	$\Delta\theta_z$	$\Delta\theta_{Cu s}$	$\Delta\theta_{Cu r}$
1	$P = P_n, \cos\varphi_n$	10.15	9.02	1.45	5.96	31.55	59.80	59.60	58.35
2	$P = 1.05 P_n, \cos\varphi_n$	10.69	9.32	1.50	6.16	33.18	64.42	64.50	61.55
3	$P = 1.1 P_n, \cos\varphi_n$	11.25	9.63	1.55	6.37	34.88	69.29	69.64	64.77
4	$P = 1.1 P_n, \cos\varphi = 0.764$	11.36	9.63	1.55	6.37	34.99	69.40	69.75	66.67

Empirical value of that temperature drop is 10-15 °C, lower values referring for thermo-reactive isolation of class F. Comparing so corrected temperature rises with maximal permitted (according to IEC 34-1 normative), a conclusion can be made that in all of three over load regimes the stator winding will be far below the limit value of an temperature rise for isolation class B. Of course, it should be kept in mind that calculated values are the average winding temperatures, so there are spots in the winding where, due to cooling circumstances, with slightly higher temperature then average, but the overload thermal reserve is big enough to cover such variations.

Temperature raises of the stator core, given in tab. 3, also do not exceed permitted values for isolation class B. The warmest part of the core are teethes with average temperature raise in the regime No. 4 only 10 °C below the limit for isolation class B. Due to uneven temperature distribution along the packages height, it can be concluded that the temperature raise on the end of packages in that regime is very close to maximal one. There is, still, the reserve of 20 °C between boundary temperatures for isolation classes B and F.

Calculated temperature raises of rotor copper in all analyzed regimes, given in tab. 3 are also significantly below the maximal value for isolation class B.

In order to verify calculation method and the accuracy of results, in tab. 4, simultaneously values of measured temperature raises on the generator No. 4 in steady-state re-

Table 4. Calculated and measured temperature raises

Temperature raises	Stator				Rotor	Air
	$\Delta\theta_{Cu}$	$\Delta\theta_{Cu out}$	$\Delta\theta_a$	$\Delta\theta_z$	$\Delta\theta_{Cu r}$	$\Delta\theta_{air}$
Calculated	59.8	49.8***	31.5	59.8	58.3	19.2
Measured	–	50.6*	36**		55	23.5

* 6 sensors average value

** 2 sensors (on the slot bottom) average value

*** Corrected value for isolation temperature drop of 10 °C

gime close to nominal and calculated values for nominal regime are given. Parameters during experimental measurement were: $P = 24.2$ MW, $Q = 18$ MV Ar $U = 11.1$ kV, $I = 1575$ A, $I_f = 633$ A, $U_f = 189.5$ V, $\theta_{\text{air in}} = 24$ °C.

Final conclusion is that, in aspect of stator and rotor heating, the generator may operate stable in all of three before mentioned regimes.

Sensitivity analysis

The previous calculation is based on certain parameters from original documentation, which are not verified by experiment. Beside that, for relative losses and for cooling air flow rate available data are very various. According to project's documentation data, relative iron losses are 2,3 W/kg by induction of 1 T, comparing to 1.56 W/kg measured by factory "Rade Končar" on the generator before delivery. The air flow rate according to documentation is 36 m³/s, unofficially its value is 70 m³/s and measurements done by Institute "Nikola Tesla" resulted in 78 m³/s. Such differences significantly reflect on accuracy of results. For comparison purposes, beside the projected parameters $p = 1.56$ W/kg and $Q_v = 36$ m³/s, calculations was also conducted with other input data:

- $p = 1.56$ W/kg, $Q_v = 78$ m³/s,
- $p = 2.3$ W/kg, $Q_v = 36$ m³/s, and
- $p = 2.3$ W/kg, $Q_v = 78$ m³/s.

Results of temperature raise calculation for nominal regime with different values of relative iron losses and air flow rate are given in tab. 5.

Table 5. Results in regime with different values of p and Q_v

Parameters		Temperature raises [°C]					
p [W/kg]	Q_v [m ³ /s]	$\Delta\theta_{\text{air}}$	$\Delta\theta_{\text{Fe a}}$	$\Delta\theta_{\text{Fe z}}$	$\Delta\theta_{\text{Cu s}}$	$\Delta\theta_{\text{Cu s}}^*$	$\Delta\theta_{\text{Cu r}}$
1.56	36	19.17	31.55	59.80	59.60	49.60	58.35
1.56	78	8.85	23.51	55.29	53.26	43.26	55.49
2.3	36	20.77	37.03	69.20	64.30	54.30	58.65
2.3	78	9.59	28.41	64.56	57.60	47.60	55.60
Measured		23.5	36		–	50.60	55.00

* Corrected value for temperature drop of 10 °C

Correlation between calculated and measured temperature raises is satisfying only for the parameter combination $p = 1.56$ W/kg and $Q_v = 36$ m³/s.

The generator particular losses measurements

As it was before mentioned, during the generator losses determining procedure the reliable data wasn't given, such as: specific stator magnetic losses on insulation losses, air flow rate, and ventilation losses.

With the aim of checking the obtainable data, the measurements of particular generator losses using the calorimetric method on generator No. 3 [4] were performed. At the same time, the generator power and temperature measurement for two operating regimes at increasing active power by 5 and 9% was performed.

Calorimetric method is the most applied method for particular generator losses measurements. The most important reasons for choosing this method are its convenience and cost-effective.

During the particular losses determination by the calorimetric method, the main assumption is that all the heat carried by air is delivered to the cooling water. The losses power is calculated by using the water flow rate and inlet and outlet water temperature measurement. For stability operating regime, for which the observed generator is researched, reaching the stationary thermal state, the losses power quantity is:

$$P_g = \rho Q c_p \Delta\theta \quad (2)$$

where P_g [kW], is the losses power, c_p [kJ/kg], the cooling water specific heat capacity depending on water inlet-outlet temperature and water pressure, Q [m³/s], the water flow rate, ρ [kg/m³], the water density, and $\Delta\theta$ [K], water temperature difference (outlet-inlet).

For relatively low cooling water temperature increase which practically can occur during the losses generator measurements (up to 15 K) the losses for stability operating regimes are determined by:

$$P_g = 4,1868 Q \Delta\theta \quad (3)$$

Particular losses were determined at three characteristic generator regimes:

- no load and no excitation generator at the nominal rotational speed,
- no load and excitation generator at the nominal voltage and at the nominal rotational speed, and
- three-pole short circuit at the nominal current and at the nominal rotational speed.

During the tests the following temperatures [°C] are measured, registered and calculated:

- θ_{win} – inlet cooling water temperature,
- θ_{wout} – outlet cooling water temperature,
- θ_{airin} – inlet cooling air temperature,
- θ_{airout} – outlet cooling air temperature,
- $\Delta\theta_w$ – cooling water temperature raise (outlet-inlet),
- $\Delta\theta_{air}$ – air temperature raise (outlet-inlet),
- θ_{amb} – ambient temperature,
- θ_{in1to6} – stator coils temperature,

- θ_{p1to3} – stator core temperature,
- θ_{rlbt} – turbine radial bearing temperature,
- θ_{drbt} – down radial bearing temperature of the generator,
- θ_{urbt} – upper radial bearing temperature of the generator,
- θ_{Tbds} – thrust bearing temperature – downstream,
- θ_{Tbup} – thrust bearing temperature – upstream, and
- θ_{btr} – block transformer oil temperature.

At the same time, the cooling water flow rate Q [m³/s] was measured. All temperatures were measured by mercuric and resistance thermometers.

On the base of these measurements for no load and no excitation generator, the generator and ventilation losses are:

$$P_{vent} \quad P_{cal} \quad P_{GW} \quad (4)$$

where P_{GW} is the heat power carried out or brought in through the generator bulk wall. The estimated value for this generator is 15 kW and P_{cal} is the total of generator losses.

Based of the measurements for the excitation and no load generator, the losses in stator active iron and additional losses are determined. For measured generator voltage they are:

$$P_{Fe} \quad P_{cal} \quad P_{GW} \quad P_f \quad P_{vent} \quad (5)$$

where P_f are rotor winding losses.

The active iron losses and additional losses are recalculated on the nominal voltage proportionate to squared voltage.

Based on the measurements for tree-pole short circuit, the copper losses are determined. They are:

$$P_{Cu} \quad P_{cal} \quad P_{GW} \quad P_f \quad P_{vent} \quad (6)$$

and they are recalculated for nominal current.

For generator efficiency determination, it is necessary to know the bearing losses. During the tests, it was adopted, for generator efficiency calculation, that the radial bearing losses and part of thrust bearing losses which are proportionate to the generator axial force in relation to the total axial force should be taken into account. That is:

$$P_{gGB} \quad P_{gRB} \quad P_{gTB} \quad (7)$$

where P_{gGB} are bearing losses belonging to the generator, P_{gRB} – the radial bearing losses and P_{gTB} – the thrust bearing losses belonging to the generator.

Results of measurement of particular losses and temperatures for over load operating regime

Using the calorimetric measurement results, the particular losses were calculated: for no load generator and no excitation – ventilating losses, for no load genera-

tor with excitation – total iron losses, at short circuit – total short circuit losses and finally bearing losses. For nominal operating points, some of the determined losses differ from the calculated ones. This comparison is given in tab. 6.

Table 6. Calculated and measured losses of generator No. 3

No.	Origin of losses	$P = P_n, \cos\varphi = 0,8$	
		Calculated value [kW]	Calorimetric method
1	Iron losses	121.7 / 163*	168
2	Copper losses	260	188
3	Ventilating losses	283.2	189
4	Bearings losses	46.6	55,5
5	Total losses	711.5 / 752.8*	600.5

* Specific losses 1.56/2.3 W/kg

The results in tab. 6 show that measurements of values by calorimetric method significantly differ from calculated values particularly for short circuit and ventilating losses. This fact imposes conclusion that ventilating losses determined by calculation are enormous, while the difference for short circuit losses cannot be explained. Iron losses determined by calorimetric method show that insulation lamination have specific losses nearer to 2.3 W/kg than specified 1.56 W/kg. Competent values for generator efficiency calculations are the measured values obtained by calorimetric method which is proposed as the most accurate method for big rotating machines according to IEC 34-2A.

Temperature condition of generator No. 3. was checked by measurement for overload power at two different operating regimes: $P = 1.048P_n$ and $P = 1.086P_n$

The other values for these regimes are given in tab. 7.

Power losses obtained by calorimetric method are recalculated to the measured voltages and current values. These results were used for generator efficiency calculation.

Stator coils and stator package temperatures were measured by built-in resistance thermometers. Temperature of the rotor coils is measured by V/I method. During this test, the oil block temperature of transformers, bearing and relevant turbine parts were measured. Temperatures [°C] measured during the heating test are:

- θ_{win} – inlet cooling water temperature,
- θ_{wout} – outlet cooling water temperature,
- θ_{airin} – inlet cooling air temperature,
- θ_{airout} – outlet cooling air temperature,
- θ_{amb} – ambient temperature,
- θ_{sc} – stator coil temperature,
- θ_{sp} – stator package temperature, and
- θ_f – rotor coil temperature, $[250(R_f/R_{15}) - 235]$.

The results for two operating regimes are given in tab. 8.

Table 7. Operating regimes 1 and 2 for increased power

	Regime 1		Regime 2	
	Calculated values	Relative values	Calculated values	Relative values
Apparent power, S [MVA]	30.738	1.0246 S_n	31.601	1.053 S_n
Real power, P [MW]	25.160	1.048 P_n	26.074	1.086 P_n
Reactive power, Q [MVA r]	17.658	0.981 Q_n	17.854	0.99 Q_n
Stator voltage, U_G [kV]	11.0	1.00 U_n	10.991	0.999 U_n
Stator current, I_G [A]	1615	1.025	1663	1.068 I_n
Excitation current, I_f [A]	615	0.976 I_{fn}	622	0.987 I_{fn}
Power factor, $\cos\phi$	0.82	1.025	0.825	1.03
Rotational speed, n [min^{-1}]	150	1.00 n_n	150	1.00 n_n
Iron P_{Fe} and additional losses, [kW]	167.79		167.79	
Losses on ventilation, P_{vent} [kW]	188.94		188.94	
Losses in bearings, P_{gGL} [kW]	55.51		55.51	
Copper losses, P_{Cu} [kW]	199		210.54	
Excitation losses, P_f [kW]	125		128	
Losses on brushes, P_c [kW]	1.23		1.244	
Total losses, P_{gG} [kW]	737.2		752	
Real power, P [kW]	25160		26074	
Input power, [kW]	25897		26826	
Efficiency factor, η [%]	97.20		97.15	

Using the results given in tab. 8, the following conclusions can be derived:

- stator coil temperature raise for operating regime 1 $S = 1.024 S_a$ is $\Delta\theta_{sc} = 49.8$ °C which shows that temperature reserve in stator coils exists,
- stator package temperature raise for operating regime 1 is $\Delta\theta_{sp} = 39.8$ °C which also shows that this result is far below the permitted value,
- rotor temperature raise is $\Delta\theta_f = 66.4$ °C for excitation current $I_f = 1.024 I_{fn}$ is below the permitted value too, and
- measured stator and rotor temperature raises for operating regime 2, the basic parameters of which are shown in tab. 8, show that temperature reserve and possibility of generator power increase for HE Zvornik exist.

Electricity production of HE Zvornik in 2005-2006 period

Relying on researches, studies and measurements carried out, as well as on experiences made so far, experts of HE Zvornik have increased the generator power up to 26 MW during the high waters periods in 2005-2006. Owing to this, $6 \cdot 10^6$ kWh of extra

electric energy was generated in 2005. This year generating increase in the first 6 months is $4.65 \cdot 10^6$ kWh which is a record for this time, and it has been reached owing to favorable hydrological situation as well as to work with increased power. Therefore, owing to the increase in unit power, energy production has been increased in the amount of $11 \cdot 10^6$ kWh, which brought the profit of 440000 € (at the price of 4 c€). There are no production costs for this increased profit, because suitable water would simply flow over the dam.

Conclusions

Based on the overall calculations and measurements carried out on HPS Zvornik generators, the following conclusions can be reached.

- Generators allow the increase in active power by which they can be burdened from 24 to 26 MW with $\cos\varphi = 0.8$.
- At this increase, coils and magnetic circuit of insulation lamination temperature doesn't go beyond allowed boundary values, but a certain reserve of about 10 °C is present.
- Generator efficiency calculated on the basis of measured particular losses is a bit higher than the projected one (almost 97.20% instead of projected 96.7%).
- Particular losses will be useful in determining the turbine efficiency level during the optimal combinatory link determination.
- During the generator revitalization with the same dimensions and increased quality of insulation lamination, coils insulation as well as cooling system, possibility of getting power at least 10% higher than the present one (*i. e.* around 26.5 to 27 MW with $\cos\varphi = 0.8$) can be expected. New turbine will also allow this generator power increase.

Remarks

The analyses and possibility of HE Zvornik power increase measurements carried out by the experts from the Faculty of Electrical Engineering and Faculty of Mechanical Engineering in Belgrade and Electrical Institute Nikola Tesla together with the experts from HPS Zvornik.

Table 8. Rotor and stator temperature conditions for operating regimes 1 and 2

Regime of operation		1	2
Electrical parameters	S [MVA]	30.738	31.601
	U [kV]	11.0	10.991
	I [kA]	1.616	1.663
	P [MW]	25.160	26.074
	Q [MVAr]	17.658	17.854
Temperature	θ_{win} [°C]	17.6	17.2
	θ_{wout} [°C]	22.2	22.2
	θ_{airin} [°C]	35.2	35.2
	θ_{airout} [°C]	51.6	52.1
	θ_{amb} [°C]	29.9	30
	θ_{sc} [°C]	85	87.7
	θ_{sp} [°C]	75	77
	θ_r [°C]	101.6	104.5
	$\Delta\theta_{sc}$ [°C]	49.8	51.8
	$\Delta\theta_{sp}$ [°C]	39.8	41.8
$\Delta\theta_r$ [°C]	66.4	69.3	

Acknowledgments

This research has been financed by Ministry of Science and Environmental Protection, in the frame of National Energy Efficiency Program, project No. 108-158B (Development program: Energy efficiency in electric power production). Research has also been supported by HPS Zvornik.

References

- [1] Petrović, D., The Calculation of the Possibility of Generator's Power Increase in HE Zvornik for Stable Operation without Constructive Changes (in Serbian), Internal report, Faculty of Electrical Engineering, University of Belgrade, January 2003, Belgrade
- [2] Petrović, D., *et al.*, The Possibility of Generator's Power Increase in the Process of Revitalization (in Serbian), Symposium Yugoslav Committee CIGRE, R11-07, 2003
- [3] Pinskiy, G. B., Dombrovskij, V. V., Hydro-Generator Calculation (in Russian), Lenjingrad, USSR, 1984
- [4] ***, The Report about a Generator's Particular Losses Determination in HE Zvornik (in Serbian), Faculty of Electrical Engineering, and Faculty of Mechanical Engineering, University of Belgrade, and Electrical Institute Nikola Tesla, Belgrade November 2005

Author's addresses:

D. Petrović, S. Stojković

Faculty of Electrical Engineering, University of Belgrade
73, Bulevar Kralja Aleksandra, 11000 Belgrade, Serbia

V. Vidaković

HE Đerdap, 19320 Kladovo, Serbia

Z. Ćirić

Electrical Institute Nikola Tesla,
8a, Koste Glavinića, 11000 Belgrade, Serbia

M. Benišek, I. Božić

Faculty of Mechanical Engineering, University of Belgrade
16, Kraljice Marije, 11000 Belgrade, Serbia

M. Dragić, M. Zeljić

HE Zvornik, 15318 M. Zvornik, Serbia

Corresponding author (S. Stojković):

E-mail: sinisa@etf.bg.ac.yu

Paper submitted: September 12, 2006

Paper revised: September 22, 2006

Paper accepted: December 1, 2006