



Wierzbicki, Damian (2022) *Freezing rooted cluster morphisms and pro-cluster algebras*. PhD thesis.

<http://theses.gla.ac.uk/83342/>

Copyright and moral rights for this work are retained by the author

A copy can be downloaded for personal non-commercial research or study, without prior permission or charge

This work cannot be reproduced or quoted extensively from without first obtaining permission in writing from the author

The content must not be changed in any way or sold commercially in any format or medium without the formal permission of the author

When referring to this work, full bibliographic details including the author, title, awarding institution and date of the thesis must be given

Enlighten: Theses

<https://theses.gla.ac.uk/>  
[research-enlighten@glasgow.ac.uk](mailto:research-enlighten@glasgow.ac.uk)

# Freezing rooted cluster morphisms and pro-cluster algebras

Damian Wierzbicki

Submitted in fulfilment of the requirements for the  
Degree of Doctor of Philosophy

School of Engineering  
College of Science and Engineering  
University of Glasgow



University  
of Glasgow

August, 2022

# Abstract

We provide a new tool for studying cluster algebras by introducing a new category **fClus** of rooted cluster algebras. We characterize isomorphisms in our new category and show that it is neither complete nor cocomplete. We give a recipe for constructing morphisms in **fClus** with an interesting geometric interpretation and study the corresponding inverse systems.

We define and study a new family of algebras, called *pro-cluster algebras*, with cluster-like combinatorics. The pro-cluster algebras are generated inside inverse limits of inverse systems in the category **fClus**. Initially, the generators of a pro-cluster algebra are grouped into certain subsets, called *pro-clusters*, of an inverse limit. In this new setting pro-clusters take the role of clusters and we construct pro-cluster algebras which are modelled by the combinatorics of infinitely marked surfaces and prove that all triangulations of those surfaces arise as pro-clusters.

# Contents

<b>Abstract</b>	<b>i</b>
<b>Acknowledgements</b>	<b>iv</b>
<b>Declaration</b>	<b>v</b>
<b>Dedication</b>	<b>vi</b>
<b>1 Introduction</b>	<b>1</b>
<b>2 Introduction to cluster algebras</b>	<b>8</b>
2.1 Definition of a cluster algebra . . . . .	8
2.1.1 Seeds . . . . .	8
2.1.2 Triangulations of marked surfaces as seeds . . . . .	10
2.1.3 Mutations . . . . .	13
2.1.4 Rooted cluster algebras . . . . .	16
2.1.5 Laurent Phenomenon and positivity . . . . .	19
<b>3 Classification of finite type cluster algebras</b>	<b>22</b>
3.1 Finite reflection groups . . . . .	22
3.1.1 Definition of a reflection group. . . . .	22
3.1.2 Root systems . . . . .	25
3.1.3 Simple systems and Cartan matrices . . . . .	27
3.1.4 Coxeter groups . . . . .	30
3.1.5 Dynkin diagram and classification of finite crystallographic reflection groups . . . . .	31
3.2 Classification of finite type cluster algebras . . . . .	34
3.2.1 Denominators and root clusters . . . . .	35
<b>4 Preliminaries on category theory</b>	<b>40</b>
4.1 Category theory . . . . .	40
4.1.1 Categories . . . . .	41

4.1.2	Functors . . . . .	45
4.1.3	Limits . . . . .	47
4.2	Inverse systems of cluster algebras of finite type $A$ . . . . .	52
<b>5</b>	<b>Freezing rooted cluster morphisms and the category of rooted cluster algebras.</b>	<b>57</b>
5.1	Freezing rooted cluster morphisms . . . . .	57
5.2	Examples of freezing rooted cluster morphisms . . . . .	60
5.3	The category of rooted cluster algebras . . . . .	63
5.4	Isomorphisms in the category <b>fClus</b> . . . . .	64
5.5	Limits and colimits in <b>fClus</b> . . . . .	68
5.6	Freezing morphisms . . . . .	70
5.6.1	Freezing morphisms between acyclic cluster algebras . . . . .	72
5.6.2	Freezing morphisms, almost positive roots and cluster variables. . . . .	88
5.6.3	Freezing morphisms from triangulations of a convex $n$ -gon . . . . .	91
<b>6</b>	<b>Pro-clusters and pro-cluster algebras</b>	<b>104</b>
6.1	Definition of a pro-cluster and a pro-cluster algebra . . . . .	104
6.2	Triangulations of linearly ordered sets . . . . .	106
6.3	Fountain pro-cluster algebras . . . . .	113
6.4	Leapfrog pro-cluster algebras . . . . .	123
6.4.1	Two one-sided limit points leapfrog pro-cluster algebra . . . . .	123
6.4.2	One two-sided limit point pro-cluster algebra . . . . .	134
6.5	Some pro-cluster algebras are cluster algebras . . . . .	145
<b>7</b>	<b>Discussion and outlook</b>	<b>148</b>
7.1	Relationship between pro-cluster algebras and cluster algebras. . . . .	148
7.2	Pro-cluster mutations versus completed mutations . . . . .	150
7.3	Outlook . . . . .	153
<b>8</b>	<b>References</b>	<b>155</b>

## Acknowledgements

Firstly, I would like to thank my supervisors: Sira Gratz and Christian Korff. I thank you for your patience, all of your hard work, ideas, support and encouragement. I feel so privileged to have had the opportunity to learn from the fantastic people and outstanding academics that you both are. All that I have learnt from you during the course of this project will benefit me forever.

I would also like to express my gratitude to all the committee members: Prof. Alex Bartel, Prof. Gwyn Bellamy and Dr. Joseph Grant. Thank you for making my viva experience so pleasant and for helping me improve my thesis by providing me with a list of valuable comments and suggestions. I greatly appreciate all your contributions.

Next, I would like to thank my partner Robyn for her infinite support, her strength and for always believing in me. Without you, none of this would ever be possible. Thank you!

I would also like to thank my beautiful children: Lucca, Matteo and Iona for being my motivation. Your smiles and laughter make everything easier and better.

I thank Joe for letting me turn one of his rooms into my office during the pandemic and for all life-related help. I am also extremely grateful to Joan for all of her help and support with the daily struggles.

I also want to thank my mum and dad for all of their support and for always believing in me.

I would also like to express my gratitude to all the staff in the mathematics Department for always being so helpful and to EPSRC for their financial support during the period of my studies.

## Declaration

With the exception of Chapters 2, 3 and 4, which contain introductory material, all work in this thesis was carried out by the author unless otherwise explicitly stated.

# Dedication

To Robyn and to our children: Lucca, Matteo and Iona.



# 1 Introduction

Cluster algebras are commutative rings living inside the field of rational functions. They are defined combinatorially, with their generators being obtained via an iterated process of *mutation*. Cluster algebras were introduced in [16] by S. Fomin and A. Zelevensky in an attempt to establish a combinatorial framework for studying total positivity and canonical bases in algebraic groups and remained a very active area of study ever since. As a consequence, since their discovery, many connections between cluster algebras and other areas of mathematics have been recognized and celebrated. There are links between cluster algebras and combinatorial geometry [13], frieze patterns [1, 3] and discrete integrable systems [20, 27], to only name a few. Throughout the rest of this introduction (and the rest of this thesis) we will expose many more relationships between cluster algebras and other areas, focusing on those that are directly related to our work presented here. For a more detailed account of other domains where cluster algebra play an important role as well as for more information regarding motivation for cluster algebras see Section 1.1 in [32] and references therein.

The generators of a cluster algebra are known as *cluster variables*. The cluster variables are grouped into overlapping subsets called *clusters*. Starting from an initial cluster, i.e. a set of algebraically independent rational functions, we obtain all the remaining cluster variables using mutations, *exchanging* one cluster variable with a new one at each mutation step. The mutation process depends on skew-symmetrisable matrices, called *exchange matrices*. At every mutation step we not only replace the cluster variable but also the exchange matrix, according to certain rules. The skew-symmetrisable matrices can be represented graphically using certain directed graphs, called *quivers*. The cluster variables within each cluster are split into two non-overlapping sets. One set contains those cluster variables that can be mutated and the other contains those cluster variables that cannot. The cluster variables that can be mutated are called *exchangeable variables* and the cluster variables that cannot be mutated are called *frozen variables* or *coefficients*. The triple

$$(cluster, exchangeable\ variables, exchange\ matrix)$$

is called a *seed*. A cluster algebra is of *finite type* if it has finitely many seeds. One of the

seminal results in the research of cluster algebras is the classification of finite type cluster algebras by Fomin and Zelevinsky [17]. Amazingly, the classification turned out to be the same as the Cartan-Killing classification of semisimple Lie algebras and finite root systems and a remarkable parametrization of cluster variables (in a finite type cluster algebra) by certain subsets of root systems, the so-called *almost positive roots*, was given in [17, Theorem 1.9].

Another striking result regarding cluster algebras is the fact that a large family of them can be encoded via the combinatorial model of marked surfaces (see, for example, [15]). In such a setting, cluster variables are identified with arcs, clusters with suitably defined triangulations and mutations with quadrilateral flips. For example, the cluster algebras of finite type  $A_n$  can be constructed using the triangulations of convex  $(n + 3)$ -gons and the cluster algebras of finite type  $D_n$  are built using the triangulations of once-punctured convex  $n$ -gons. If a cluster algebra can be realized in this way, then we say that it comes from, or that it is associated with, a given marked surface.

In the context of classifying cluster algebras it is natural to look at maps between cluster algebras preserving their structure. A natural requirement for a ring homomorphism between cluster algebras is that it should commute with mutations in an appropriate sense. For a bijective morphism from a coefficient-free skew symmetric cluster algebra to itself, this gives rise to the notion of cluster automorphisms, introduced in [4]. Another example in this direction is [12], where Fraser defined maps between cluster algebras of the same type but with different coefficients. In [2] Assem, Dupont and Schiffler introduced the notions of *rooted cluster algebra*, that is cluster algebras that come as a pair together with a fixed seed called *the root*, and of *rooted cluster morphism*. Informally, a rooted cluster morphism is a ring homomorphism between cluster algebras that in addition satisfies the following three conditions:

- (i) it must send cluster variables in the fixed initial cluster (of the root) to cluster variables of the root or to integers,
- (ii) it must send exchangeable variables in the fixed initial cluster (of the root) to exchangeable variables of the root or to integers,

(iii) it must commute with mutations in an appropriate sense.

Identifying rooted cluster algebras as objects and rooted cluster morphisms as morphisms, respectively, defines the category **Clus** (see [2, Definition 2.6]). In **Clus**, maps between cluster algebras of different types are now allowed.

Originally, the clusters in a cluster algebra are defined to be finite sets [16]. In [21] Gratz and Grabowski remove that restriction and define *infinite rank cluster algebras* by allowing countably infinite clusters while keeping the other axioms of a cluster algebra unchanged. In particular, for a given initial seed, only finite sequences of mutations that start at that initial seed are allowed. As a consequence, not every orientation of the initial quiver shows up during the mutation process and the cluster algebras that one obtains depend on the choice of the initial quiver in the initial seed.

In similar spirit, Çanakçı and Felikson [10] generalize cluster algebras coming from marked surfaces to the case of infinitely marked surfaces. The surfaces are now allowed to have countably infinitely many marked points, with finitely many *accumulation* marked points. These authors show in [10] that in order to connect any two triangulations infinite sequences of mutations, or equivalently, of diagonal flips, are necessary (see also [7]). Therefore, as in the case of infinite rank cluster algebras of Gratz and Grabowski, one does not see all of the triangulations of a (infinitely) marked surface at hand if one sticks to the classical setup and only allows for finite sequences of mutations.

Instead, we consider certain limit construction in an *appropriate category*. This category, the definition of which is one of the main outcomes of this thesis, has the same objects as **Clus** but a different notion of morphisms, the so-called *freezing rooted cluster morphisms* (Definition 5.2). Our definition (of morphisms) remains centered on the idea that morphisms between cluster algebras should commute with mutations. However, in contrast to rooted cluster morphisms, we allow exchangeable variables to be sent to frozen ones, while forbidding frozen variables to be sent to exchangeable ones. Slightly more formally, the condition (ii) is replaced by the condition (ii'):

(ii'): frozen variables can only be sent to frozen variables or to integers.

We call the collection of all rooted cluster algebras and all freezing rooted cluster morphisms

between them **fClus** and by viewing rooted cluster algebras as objects and freezing rooted cluster morphisms as morphisms between those objects we arrive at the following result.

**Theorem 1.** (Section 5.3). **fClus** ensembles into a category.

We consider inverse systems in **fClus** and define *pro-clusters* (Definition 6.2). These are the subsets of the inverse limits (in the category of rings) lifted from clusters of the rooted cluster algebras in the corresponding inverse system. Informally, we can think of pro-clusters as a way of combining infinitely many clusters. With that notion, we then define a special family of algebras, called *pro-cluster algebras* (Definition 6.6): a pro-cluster algebra is the ring that is generated inside an inverse limit by all the distinct elements of all pro-clusters.

There is a remarkable connection between pro-cluster algebras and infinite rank cluster algebras. The pro-cluster algebras that we compute in Theorems 6.24, 6.39 and 6.51 of this thesis are equal as rings to the infinite cluster algebras of Gratz and Grabowski [21] and of Çanakçi and Felikson [10] for a suitable choice of the initial quiver and the initial triangulation, respectively. However, in comparison to previous constructions, our pro-cluster algebras are defined in a more general, surface-independent, purely algebraic way. Moreover, they have the advantage of seeing all orientations of the initial quiver, or equivalently, all triangulations of a surface. To show this, we propose an algebraic interpretation of a two-dimensional disk with a discrete set of marked points and certain accumulation marked point(s) as linearly ordered sets. Suitably defined triangulations of those sets coincide with the triangulations of the infinitely marked disks. We prove that under that interpretation:

**Theorem 2.** (Theorems 6.21, 6.36 and 6.48). All triangulations of the infinitely marked disks show up as pro-clusters of pro-cluster algebras coming from a suitably defined inverse systems of rooted cluster algebras and freezing rooted cluster morphisms between them.

The above mentioned combinatorics of triangulations of disks with finitely and infinitely many marked points has been shown to provide a model for certain categories. For example, Buan, Marsh, Reineke, Reiten and Todorov show in [9] that indecomposable objects in a category  $\mathcal{C}$ , the so-called *cluster category*, which is obtained as a quotient of the bounded derived category of the module category of a finite-dimensional hereditary algebra over a field, correspond to diagonals of a convex polygon with its triangulations corresponding to

certain subcategories of  $\mathcal{C}$ . Furthermore, in [23], [5] or [6], the respective authors extend this idea further and consider categories that are modeled by the combinatorics of unit circles with countably infinitely many marked points. In other words, certain categories can be encoded using the underlying combinatorial models of pro-cluster algebras coming from inverse systems in **fClus** and, thus, this thesis provides an algebraic counterpart, with cluster-like combinatorics, for the description of such categories.

We also discuss different examples of freezing rooted cluster morphisms between cluster algebras of different types and investigate certain properties of the category **fClus**. More concretely, we show in Corollary 5.19 that the isomorphisms in the category **fClus** coincide with the bijective freezing rooted cluster morphisms and in Theorem 5.20 that the category **fClus** is neither complete nor cocomplete.

In [22] Gratz gave a necessary and sufficient condition for a ring homomorphism between cluster algebras to give rise to a rooted cluster morphism that sends no cluster variable to an integer. Here we take an initial step towards characterizing *freezing morphisms*, that is the freezing rooted cluster morphisms that send exchangeable variables to frozen variables. In Proposition 5.22, we provide a necessary condition for freezing of a single exchangeable variable. We prove that if there is a unique exchangeable variable (in the cluster of the root) that is sent to a frozen variable by a freezing morphism, then it is necessarily *connected* to at least one frozen variable in the quiver of the root.

In [2, Section 4] the authors constructed rooted cluster morphisms from a rooted cluster algebra associated with a convex  $n$ -gon to a rooted cluster algebra associated with a convex  $(n+1)$ -gon. Geometrically, those rooted cluster morphisms correspond to *injecting* a smaller  $n$ -gon into the bigger  $(n+1)$ -gon, in the most natural way. We invert this setup and construct (Definition 4.22) parameter-dependent ring homomorphisms (Proposition 4.24) from a cluster algebra associated with a convex  $(n+1)$ -gon to a cluster algebra associated with a convex  $n$ -gon and prove in Section 5 that for a certain choice of parameters and a suitable choice of the initial triangulation they yield freezing morphisms in the category **fClus**. Geometrically, these maps are based on the idea of *collapsing* triangles. To show that our construction might be generalized to type  $D$  (rooted) cluster algebras we provide a concrete example of a *collapsing* triangle based freezing morphism from a suitably rooted

cluster algebra coming from a 9-gon with a single puncture to a suitably rooted cluster algebra coming from a once-punctured 8-gon (Example 5.36).

The freezing morphisms corresponding to *collapsing* triangles are a special case of a more general construction. An exchangeable variable in a cluster of a seed is said to be *freezeable* if it is connected (in the quiver of the seed) to two frozen variables that are not connected to any other exchangeable variable and are such that one of them *sends an arrow to* and the other one *receives an arrow from* the exchangeable variable which they are connected to. Below are examples of two quivers with a freezeable variable marked with a blue dot and the frozen variables marked with squares.

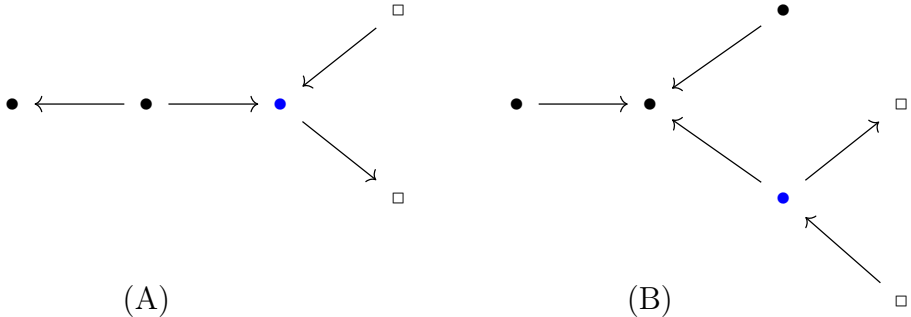

A seed which has freezeable variables is called a *freezeable seed*. We define a parameter-dependent map (Definition 5.32) from a cluster of a freezeable seed to a cluster of a seed which is constructed as follows: turn one of the freezeable variables  $x$  to a frozen variable, and remove all pairs of frozen variables that are connected to  $x$  in the way described in the previous paragraph, while keeping the remaining part of the quiver untouched. See below for an example of this operation performed on the two quivers above.

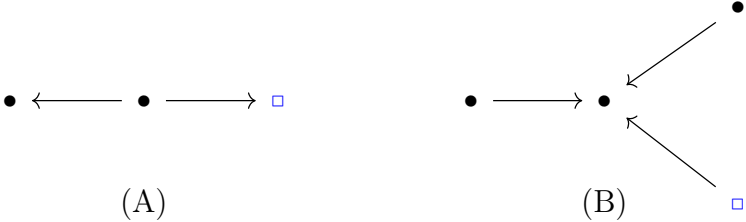

Another key result is that we prove in Theorem 5.33 that such maps yield freezing morphisms between acyclic cluster algebras. This particular example of a freezing cluster morphism is especially important since we provide a simple recipe for constructing maps between acyclic cluster algebras, in particular those of different finite types and different ranks.

We also propose a reformulation of the maps described in the previous paragraph that makes use of the correspondence between cluster variables and almost positive roots and show in Theorem 5.39 that the reformulated maps yield freezing rooted cluster morphisms between cluster algebras of finite type.

The thesis is organized as follows. Chapters 2, 3 and 4 are dedicated to providing the necessary background material while Chapters 5, 6 and 7 contain the new results. In Chapter 2 we introduce rooted cluster algebras. Chapter 3 offers a condensed review of classification of cluster algebras of finite type. Chapter 4 gives the reader a preliminary exposition to category theory and we define a family of parameter dependent ring homomorphisms between cluster algebras, of different ranks, from convex polygons.

In Chapter 5 we define the category **fClus**, study some of its properties and morphisms within it. Chapter 6 is concerned with pro-cluster algebras and important examples. In Chapter 7 we briefly discuss possible extensions of our work.

## 2 Introduction to cluster algebras

The main objects that this thesis will focus on are certain commutative rings, called *cluster algebras*. In a typical setup one is given all of the generators needed to construct an algebra. This is not the case for cluster algebras. Here we are given only a subset of generators and a combinatorial recipe to iteratively build the rest of them. The combinatorics encodes a special notion of *positivity* which leads to many beautiful results, some of which we will showcase in this thesis and expand and none of which, subjectively speaking, will appear obvious from looking at the basic definitions.

In this chapter we give the formal definition of cluster algebras of geometric type and discuss some of their preliminary properties. The initial exposition we provide will rely upon the exposition written by Fomin and Zelevinsky [17] and the exposition written by Assem, Dupont and Schiffler [2].

### 2.1 Definition of a cluster algebra

Cluster algebras are commutative rings embedded in an ambient field  $\mathcal{F}$ , the field of rational functions in countably many independent variables and with coefficients in  $\mathbb{Q}$ . Cluster algebras are generated by a subset of  $\mathcal{F}$ , which is obtained from certain initial data via the process of so-called mutation.

#### 2.1.1 Seeds

Assume  $I$  is a countable set. A matrix  $A = (a_{ij})_{i,j \in I}$  is *locally finite* if for every  $i \in I$ , the families  $(a_{ij})_{j \in I}$  and  $(a_{ji})_{j \in I}$  have finite support. We denote by  $M_I(\mathbb{Z})$  the ring of locally finite integer matrices with its entries indexed by  $I \times I$ . We say that a matrix  $B \in M_I(\mathbb{Z})$  is *skew-symmetrisable* if there exists a family of non-negative integers  $(d_i)_{i \in I}$  such that  $d_i b_{ij} = -d_j b_{ji}$  for any  $i, j \in I$ . We call a skew-symmetrisable matrix  $B \in M_I(\mathbb{Z})$  an *alternating matrix* if  $I = I_+ \cup I_-$ , where  $I_+ = \{i \in I : b_{ij} > 0 \text{ for all } i \neq j \in I\}$  and  $I_- = \{i \in I : b_{ij} < 0 \text{ for all } i \neq j \in I\}$ . If  $B \in M_I(\mathbb{Z})$  and if  $J$  is a subset of  $I$ , we denote by  $B[J] = (b_{ij})_{i,j \in J}$  the submatrix of  $B$  formed by the entries labelled by  $J \times J$ .

The so-called seeds are the source of the initial data we mentioned at the start of this



section.

**Definition 2.1.** ([17, Section 1.2]). A *seed* is a triple  $\Sigma = (X, ex, B)$  where:

- $X$  is a countable set of indeterminates over  $\mathbb{Z}$ , i.e. the field  $\mathcal{F} = \mathbb{Q}(x|x \in X)$  of rational functions in  $X$  is a purely transcendental field extension of  $\mathbb{Q}$ . The set  $X$  is called the *cluster* of  $\Sigma$ .
- $ex \subseteq X$  is a subset of the cluster whose elements are called the *exchangeable variables* of  $\Sigma$ . The elements  $X \setminus ex$  are called the *coefficients* (or the *frozen variables*) of  $\Sigma$ .
- $B = (b_{xy})_{x,y \in X} \in M_X(\mathbb{Z})$  is a skew-symmetrisable matrix, called the *exchange matrix* of  $\Sigma$ .

If a seed  $\Sigma = (X, ex, B)$  is such that  $X \setminus ex = \emptyset$  then we call  $\Sigma$  *coefficient-free* and simply write  $\Sigma = (X, B)$  in such case, for brevity. A seed is called *finite* if  $X$  is a finite set. In general, we will denote the ambient field  $\mathcal{F} = \mathbb{Q}(x|x \in X)$  simply by  $\mathcal{F}_\Sigma$ .

It is often convenient to interpret exchange matrices in terms of special class of directed graphs, called quivers. Here we describe this connection in detail only for exchange matrices that are skew-symmetric, since we will deal almost exclusively with cluster algebras arising from skew-symmetric matrices. For an extension of the discussion to skew-symmetrisable matrices, see [32, Section 2.4].

**Definition 2.2.** ([35, Definition 2.1]). A *quiver*  $Q$  is an oriented graph given by a set of vertices  $Q_0$ , a set of arrows  $Q_1$  between vertices  $Q_0$ , and two maps  $s : Q_1 \rightarrow Q_0$  and  $t : Q_1 \rightarrow Q_0$  taking an arrow to its source and target, respectively.

If a vertex  $i \in Q_0$  of a quiver  $Q$  is such that  $s^{-1}(i) \neq \emptyset$  and  $t^{-1}(i) = \emptyset$  then we call  $i$  a *source*. Similarly, if  $s^{-1}(i) = \emptyset$  and  $t^{-1}(i) \neq \emptyset$  then we call  $i$  a *sink*. If there are  $k \geq 1$  arrows between vertices  $i, j \in Q_0$ , then we write  $k \bullet i \rightarrow j$  to express that. A quiver  $Q$  is said to be *finite* if both  $Q_0$  and  $Q_1$  are finite sets. A loop of a quiver is an arrow  $i$  whose source and target coincide. A 2-cycle of a quiver is a pair of distinct arrows  $i$  and  $k$  such that  $s(i) = t(k)$  and  $t(k) = s(i)$ .

A skew-symmetric matrix  $B \in M_I(\mathbb{Z})$  encodes a quiver  $Q_B$ , with the set of vertices  $Q_0 = I$  and with the set of arrows  $Q_1 = \{b_{ij} \bullet i \rightarrow j | b_{ij} > 0\}$ .

**Example 2.3.** Below we can see a skew-symmetric  $B$  and its corresponding quiver  $Q_B$ .

$$B = \begin{pmatrix} 0 & -1 & 1 \\ 1 & 0 & -1 \\ -1 & 1 & 0 \end{pmatrix} \longleftrightarrow Q_B = \begin{array}{ccc} & 2 & \\ \swarrow & & \searrow \\ 1 & \longrightarrow & 3. \end{array}$$

Note that  $Q_B$  has no loops (1-cycle) or 2-cycles.

The local finiteness property of  $B$  translates into  $Q_B$  having only finitely many arrows incident with every vertex. Moreover, if  $B$  is alternating then every vertex of  $Q_B$  is either a sink or a source. By abuse of notation we will often write  $\Sigma = (X, ex, Q_B)$  for the seed  $\Sigma = (X, ex, B)$ , if  $B$  is skew-symmetric. Given a seed  $\Sigma = (X, ex, Q_B)$  we will sometimes refer to a vertex of  $Q_B$  as exchangeable (respectively, frozen) if it corresponds to an exchangeable (respectively, frozen) variable.

### 2.1.2 Triangulations of marked surfaces as seeds

Let us first recall what marked surfaces are.

**Definition 2.4.** ([15, Definition 2.1]). A *marked surface* is a pair  $(S, M)$  where

- $S$  is a connected oriented 2-dimensional Riemann surface with a boundary  $\partial S$
- $M$  is a finite set of marked points in the closure of  $S$  such that each connected component of  $\partial S$  contains at least one marked point in  $M$ .

If a marked point lies in the interior of  $S$  then we call it a *puncture*.

Defining marked surfaces in the way we did allows us to talk about their so-called triangulations. Informally, we can think of a triangulation drawing paths on the surface between marked points until cutting along the drawn paths results with a set of disconnected triangles. Triangulations of marked surfaces serve as an important source of seeds for cluster algebras. In order to eliminate the surfaces with no triangulations or only a single triangulation we must also assume that  $(S, M)$  is not one of the following:

- a sphere with one, two or three punctures,
- an unpunctured or a once-punctured monogon,

- an unpunctured digon or an unpunctured triangle.

Now the task at hand is to describe a way in which we can attach a (skew-symmetric) matrix, or equivalently a quiver, to a triangulation of a marked surface. Here we intend to provide the reader with a working understanding of this construction, rather than giving the full exposition. For the latter, we refer the reader to the source material by Fomin, Shapiro, and Thurston [15]. But before we do this, we have to first define triangulations of marked surfaces in a formal way.

In what follows, when we are talking about a curve in  $S$  that connects two marked points in  $(S, M)$ , we are effectively talking about a representative of its isotopy class in  $S$  with respect to the set  $M$ . If two curves  $\alpha, \alpha'$  do not belong to the same isotopy class then they are said to be *distinct*. On the other hand, if  $\alpha, \alpha'$  are such that there are curves in their respective isotopy classes that do not intersect in  $S \setminus M$  then we say that  $\alpha$  and  $\alpha'$  are *compatible*.

**Definition 2.5.** ([15], Definition 2.2). An *arc* in  $(S, M)$  is a curve in  $S$  with endpoints in  $M$  and which is compatible with itself, except that its endpoints may coincide.

If an arc of  $(S, M)$  is isotopic to a connected component of  $\partial S \setminus M$  then we call it a *boundary arc* and an *internal arc* otherwise. In Definition 2.1 of a seed we made a distinction between frozen and exchangeable variables and hence why the distinction between boundary arcs and internal arcs is needed. We will make this more precise shortly.

**Definition 2.6.** ([15, Definition 2.6]). A *triangulation* of  $(S, M)$  is a maximal collection of arcs which are pairwise distinct and compatible. The arcs of the triangulation cut the surface into triangles.

Before moving forward, we note that in [15] the authors allow for the triangles in a triangulation to have two distinct sides rather than three. Such triangles are referred to as *self-folded* triangles. However, since we will only be concerned with triangulations where no self-folded triangles will ever appear, every triangulation we will consider from this point onward is always assumed to have no self-folded triangles.

We will now explain how we can associate to each triangulation  $T$  of  $(S, M)$  a skew-symmetric matrix  $B^T$ , following closely Definition 4.1 in [15]. For any triangle  $\Delta$  in  $T$ , we define a matrix  $B^\Delta$ , indexed by the arcs (both boundary and internal) in  $T$  and given by

$$B_{\gamma, \gamma'}^\Delta = \begin{cases} 1 & \text{if } \gamma \text{ and } \gamma' \text{ are sides of } \Delta \text{ and } \gamma' \text{ follows } \gamma \text{ in the clockwise order;} \\ -1 & \text{if } \gamma \text{ and } \gamma' \text{ are sides of } \Delta \text{ and } \gamma' \text{ follows } \gamma \text{ in the anticlockwise order;} \\ 0 & \text{otherwise.} \end{cases}$$

The matrix  $B^T$  is then given by

$$B^T = \sum_{\Delta} B^\Delta, \tag{1}$$

where the above sum runs over all triangles in  $T$ . We then associate with  $T$  the *seed*  $\Sigma_T = (X_T, ex_T, B^T)$  where:

- $X_T = \{x_\gamma : \gamma \text{ is an arc in } T\}$ ;
- $ex_T = \{x_\gamma : \gamma \text{ is an internal arc in } T\}$ ;
- $B^T$  is the skew-symmetric matrix as in (1) above.

We can construct the quiver  $Q_T$  corresponding to  $B^T$  directly from  $T$  in the following way:

- the vertices in  $Q_T$  are the arcs of  $T$ ,
- the frozen vertices in  $Q_T$  are the boundary arcs of  $T$ ,
- there is an arrow  $\gamma \rightarrow \gamma'$  if and only if  $\gamma$  and  $\gamma'$  are distinct sides of the same triangle in  $T$  and  $\gamma'$  follows  $\gamma$  in the clockwise direction,
- a maximal collection of 2-cycles is removed.

**Example 2.7.** Figure 1 shows an example of quiver obtained from a triangulation of a disk with 6 marked points on its boundary, regarded here as triangulation of a hexagon. Squares correspond to frozen variables and points correspond to exchangeable variables.

We sometimes treat the matrix  $B$ , the quiver  $Q_B$ , the matrix  $B^T$  and the quiver  $Q_T$  as being the same object without further comment.

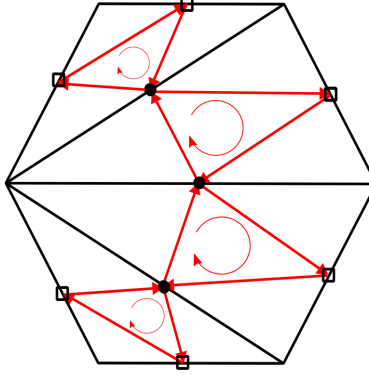

Figure 1: A triangulation of a hexagon and the corresponding quiver.

### 2.1.3 Mutations

A seed  $\Sigma = (X, ex, B)$  contains all the data needed to construct the associated cluster algebra. We will now define seed mutation. By applying mutation successively, we will obtain all the generators needed for constructing the cluster algebra. The information required to perform mutation is encoded in the exchange matrix  $B$ .

**Definition 2.8.** ([17, Definition 1.1]). Given a seed  $\Sigma = (X, ex, B)$  and an exchangeable variable  $x \in ex$ , the image of the *mutation* of  $\Sigma$  in the direction of  $x$  is the seed

$$\mu_x(\Sigma) = (X', ex', B') = \Sigma'$$

where the data of  $\Sigma'$  are obtained from  $\Sigma$  as follows:

1)  $X' = (X \setminus \{x\}) \sqcup \{x'\}$  where

$$xx' = \prod_{\substack{y \in X; \\ b_{xy} > 0}}^m y^{b_{xy}} + \prod_{\substack{y \in X; \\ b_{xy} < 0}}^m y^{-b_{xy}} \quad (2)$$

2)  $ex' = (ex \setminus \{x\}) \sqcup \{x'\}$ ;

3)  $B' = (b'_{yz}) \in M_X(\mathbb{Z})$  is given by

$$b'_{yz} = \begin{cases} -b_{yz}, & \text{if } x = y \text{ or } x = z \\ b_{yz} + \frac{1}{2}(|b_{yx}|b_{xz} + b_{yx}|b_{xz}|), & \text{otherwise.} \end{cases} \quad (3)$$

For any  $y \in X$  we will denote by  $\mu_{x,\Sigma}(y)$  the cluster variable in the cluster  $X'$  of the seed  $\mu_x(\Sigma)$  corresponding to  $y$ . This means that  $\mu_{x,\Sigma}(y) = y$  if  $y \neq x$  and  $\mu_{x,\Sigma}(y) = x'$  if  $y = x$ , where  $x'$  is defined as in (2) above. If clear from context, we will use the shortened notation  $\mu_x(y)$  instead of  $\mu_{x,\Sigma}(y)$ .

We highlight here two important well-known facts. Let  $\Sigma = (X, ex, B)$  be a seed and let  $x \in ex$ . Then

1.  $\mu_{\mu_x(x)} \circ \mu_x(\Sigma) = \Sigma$ , i.e. mutation is *involutive*,
2. the cluster of the seed  $\Sigma'$  is a transcendence basis of the ambient field  $\mathcal{F}_\Sigma$ .

**Example 2.9.** Let  $\Sigma = (\{x_1, x_2, x_3\}, B)$ , where

$$B = \begin{pmatrix} 0 & -1 & 1 \\ 1 & 0 & -1 \\ -1 & 1 & 0 \end{pmatrix}.$$

Mutating  $\Sigma$  in direction 1 gives  $(\{x'_1, x_2, x_3\}, B')$  where

$$x'_1 = \frac{x_2 + x_3}{x_1}$$

and where

$$B' = \begin{pmatrix} 0 & 1 & -1 \\ -1 & 0 & 0 \\ 1 & 0 & 0 \end{pmatrix}.$$

Of course a natural thing to do next is to define the equivalent of the rule (3) from Definition 2.8 for quivers, in a way that will make the following diagram commute.

$$\begin{array}{ccc} \Sigma = (X, ex, B) & \xrightarrow{\mu_x(\Sigma)} & \Sigma = (X', ex', B') \\ \downarrow & & \downarrow \\ \Sigma = (X, ex, Q_B) & \xrightarrow{\mu_x(\Sigma)} & \Sigma = (X', ex', Q_{B'}) \end{array}$$

This is done as follows.

**Definition 2.10.** ([35, Definition 2.2]). Let  $B \in M_I(\mathbb{Z})$  be skew-symmetric. The mutation of the quiver  $Q_B$  at vertex  $k \in I$  is defined as follows.

- (a) For all paths of the form  $i \rightarrow k \rightarrow j$  add an arrow from  $i$  to  $j$ . The multiplicity is taken into account, i.e. if there are  $a$  arrows from  $i$  to  $k$  and  $b$  arrows from  $k$  to  $j$ , we add  $ab$  arrows from  $i$  to  $j$ .
- (b) Cancel a maximal set of 2-cycles from those created in (a).
- (c) Reverse all arrows incident with  $k$ .

**Example 2.11.** Consider the matrix  $B$  and the corresponding quiver  $Q_B$ :

$$B = \begin{pmatrix} 0 & -1 & 1 \\ 1 & 0 & -1 \\ -1 & 1 & 0 \end{pmatrix} \longleftrightarrow Q_B = \begin{array}{ccc} & 2 & \\ \swarrow & & \searrow \\ 1 & \longrightarrow & 3. \end{array}$$

Applying quiver mutation to  $Q_B$  at 1 results in the quiver

$$3 \longrightarrow 1 \longrightarrow 2 ,$$

with the corresponding matrix

$$\begin{pmatrix} 0 & 1 & -1 \\ -1 & 0 & 0 \\ 1 & 0 & 0 \end{pmatrix},$$

which is the same as the matrix we obtained by applying matrix mutation to  $B$  at 1 in Example 2.9.

Now that we have established a way of constructing an exchange skew-symmetric matrix (and so, a quiver) from a triangulation of a marked surface, the natural question is what does mutation correspond to geometrically. To answer this question let  $(S, M)$  be a marked surface,  $T$  a triangulation of  $(S, M)$  and  $\Sigma_T = (X_T, ex_T, B^T)$  the corresponding seed. We will denote an arc of  $(S, M)$  by  $\{x, y\}$  where  $x, y \in M$  are the end points of that arc and denote the corresponding cluster variable by  $\{x, y\}$  too, instead of  $x_{\{x, y\}}$ , for simplicity. Moreover, we will call an exchangeable (respectively, frozen) variable  $\{x, y\}$  simply an internal arc or a diagonal (respectively, a boundary arc or an edge) if no ambiguity is caused by doing so. As it turns out, the mutation of  $\Sigma_T$  at an exchangeable variable can be represented by a so-called diagonal flip of  $T$ . In simple words, a diagonal flip replaces an arc with the only

non-isotopic arc which still produces a proper triangulation. Slightly more formally, every internal arc  $\{x, y\} \in ex_T$  is the diagonal of a unique quadrilateral with vertices  $x, w, y, z \in M$ , whose sides  $\{x, w\}, \{w, y\}, \{y, z\}$  and  $\{z, x\}$  are all contained in  $T$ . The *diagonal flip* of  $T$  at  $\{x, y\}$  replaces the arc  $\{x, y\}$  in  $T$  with the arc  $\{w, z\}$  and leaves all the other arcs untouched, resulting in a triangulation  $(T \setminus \{x, y\}) \cup \{w, z\}$ . See Figure 2 for an example of a diagonal flip in a triangulation of a hexagon.

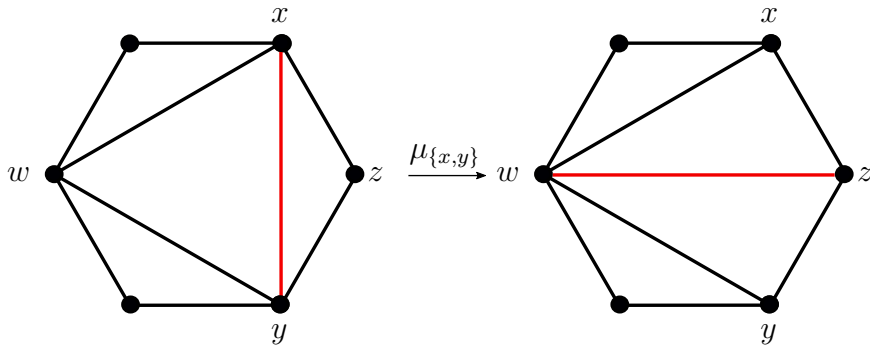

Figure 2: A diagonal flip of an arc  $\{x, y\}$  of a hexagon.

#### 2.1.4 Rooted cluster algebras

We have now gathered all the tools and materials needed to construct a cluster algebra. The construction goes as follows. We start with the initial seed. Mutating the initial seed in direction of an exchangeable variable from the corresponding cluster gives us another seed, enabling us to apply another mutation to the newly obtained seed. Collecting all distinct variables from the clusters of all seeds that are reachable from the initial seed by a sequence of so-called admissible mutations will provide a prescribed set of generators of the cluster algebra associated to the initial seed. We will now make this rather informal description formal.

**Definition 2.12.** ([2, Definition 1.3]). Let  $\Sigma = (X, ex, B)$  be a seed. For  $l \geq 1$  a sequence  $(x_1, \dots, x_l)$  is called  $\Sigma$ -admissible if  $x_1 \in ex$  and for every  $2 \leq k \leq l$ , we have  $x_k \in \mu_{x_{k-1}} \circ \dots \circ \mu_{x_1}(ex)$ . The empty sequence of length  $l = 0$  is  $\Sigma$ -admissible for every seed  $\Sigma$  and mutation



of  $\Sigma$  along the empty sequence leaves  $\Sigma$  unchanged.

Consider the set of all seeds. We say that two seeds  $\Sigma$  and  $\Sigma'$  are equivalent if and only if there is a  $\Sigma$ -admissible sequence  $(x_1, \dots, x_l)$  such that  $\Sigma' = \mu_{x_l} \circ \dots \circ \mu_{x_1}(\Sigma)$ . It is easy to see that this relation is an equivalence relation on the set of all seeds. We call the equivalence class of a seed  $\Sigma$ , under this equivalence relation, the *mutation class* of  $\Sigma$  and denote it by  $\text{Mut}(\Sigma)$ . That is,

$$\text{Mut}(\Sigma) = \{\mu_{x_l} \circ \dots \circ \mu_{x_1}(\Sigma) \mid l \geq 0, (x_1, \dots, x_l) \text{ is } \Sigma\text{-admissible}\}.$$

If two seeds are in the same mutation class then we say that they are *mutation equivalent*.

We will denote by  $\mathcal{X}_\Sigma$  the set

$$\mathcal{X}_\Sigma = \{x \in X' : (X', ex', B') \in \text{Mut}(\Sigma)\} \subseteq \mathcal{F}_\Sigma$$

of all exchangeable and of all frozen variables arising in the clusters of seeds which are mutation equivalent to a seed  $\Sigma$ .

We are now ready to define the cluster algebra associated with a given seed  $\Sigma$ . We start with a classical definition of Fomin and Zelevinsky [17].

**Definition 2.13.** ([2, Definition 1.4]). Let  $\Sigma = (X, ex, B)$  be a seed. The *cluster algebra associated* to  $\Sigma$  is the  $\mathbb{Z}$ -subalgebra of its ambient field  $\mathcal{F}_\Sigma$  given by:

$$\mathcal{A}(\Sigma) = \mathbb{Z}[x \mid x \in \mathcal{X}_\Sigma] \subseteq \mathcal{F}_\Sigma.$$

The elements of  $\mathcal{X}_\Sigma$  are called *cluster variables* (or the *exchangeable variables* and *frozen variables*, respectively) of the cluster algebra  $\mathcal{A}(\Sigma)$ . We call the cluster algebra  $\mathcal{A}(\Sigma)$  skew-symmetrisable, if the matrix  $B$  is skew-symmetrisable. The *rank* of the cluster algebra  $\mathcal{A}(\Sigma)$  is defined as the cardinality of the set of exchangeable variables of  $\Sigma$ .

Next we introduce the pointed version of a cluster algebra  $\mathcal{A}(\Sigma)$ , so-called rooted cluster algebra. They were first introduced by Assem, Dupont and Schiffler [2] in order to construct a category of cluster algebras where the morphisms are mutation preserving maps. Two seeds in the same mutation class will give rise to the same cluster algebra but to two different rooted cluster algebras.

**Definition 2.14.** The *rooted cluster algebra with initial seed*  $\Sigma$  is the pair  $(\mathcal{A}(\Sigma), \Sigma)$ , where  $\mathcal{A}(\Sigma)$  is the cluster algebra associated to  $\Sigma$ .

**Remark 2.15.** The notation introduced in Definition 2.13 extends naturally to Definition 2.14. That is, when we talk about cluster variables and the rank of a rooted cluster algebra  $(\mathcal{A}(\Sigma), \Sigma)$  we mean the cluster variables and the rank of  $\mathcal{A}(\Sigma)$ . Similarly, when we say that  $(\mathcal{A}(\Sigma), \Sigma)$  is skew-symmetrisable we mean that  $\mathcal{A}(\Sigma)$  is.

**Example 2.16.** If  $\Sigma = (\emptyset, \emptyset, \emptyset)$ , then  $\text{Mut}(\Sigma) = \emptyset$  and so  $\mathcal{A}(\Sigma) \cong \mathbb{Z}$ . If  $\Sigma = (X, \emptyset, B)$  has no exchangeable variables, then  $\text{Mut}(\Sigma) = \{\Sigma\}$  and so  $\mathcal{A}(\Sigma) \cong \mathbb{Z}[x | x \in X]$  is isomorphic to a polynomial ring in countably many variables. For a non-trivial example let us consider the following. Let  $\Sigma = (\{x_1, x_2\}, x_1 \rightarrow x_2)$  be a seed. We can think of  $\text{Mut}(\Sigma)$  as a graph whose vertices are seeds and whose edges are mutations of length 1. That is, we draw an edge between two seeds  $\Sigma', \Sigma'' \in \text{Mut}(\Sigma)$  if and only if  $\mu_{x'}(\Sigma') = \Sigma''$  for some  $x' \in ex'$ . The mutation class of  $\Sigma$  can be pictured as follows.

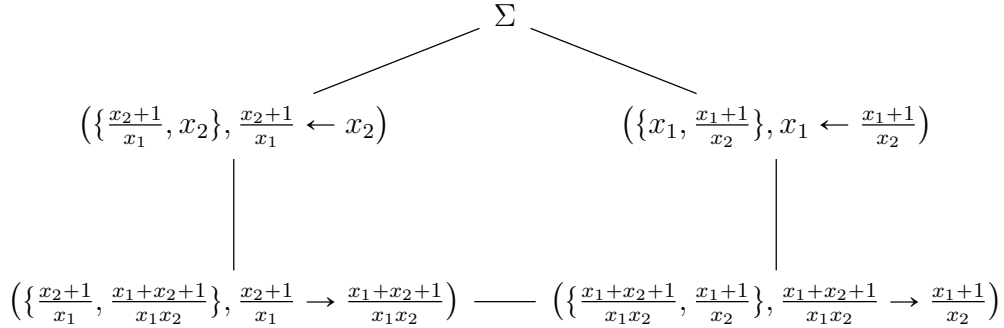

We then have that

$$\mathcal{K}_\Sigma = \left\{ x_1, x_2, \frac{x_2+1}{x_1}, \frac{x_1+1}{x_2}, \frac{x_1+x_2+1}{x_1x_2} \right\}$$

and that  $\mathcal{A}(\Sigma) = \mathbb{Z}[\mathcal{K}_\Sigma]$ .

The graph from the Example 2.16 is an example of a more general notion of the so-called *exchange graph*. See, for example, [16, §7] or [32, Definition 2.5.1].

**Remark 2.17.** (a) The definition of cluster algebra given here is not the most general one. In many situations, the inverses of the coefficients are also chosen as generators. For more information on definitions of cluster algebras, see, for example, [17, 19].

(b) Let  $T$  be a triangulation of  $(S, M)$ . It is proved in [15] that for every triangulation  $T'$  of  $(S, M)$  we have that  $\Sigma_{T'} \in \text{Mut}(\Sigma_T)$  and so, up to a ring isomorphism, the cluster algebra  $\mathcal{A}(\Sigma_T)$  associated with the triangulation  $T$  does not depend on the choice of the triangulation  $T$ . Therefore we will sometimes talk about *the cluster algebra  $\mathcal{A}(S, M)$  associated with  $(S, M)$* , without explicitly stating the choice of the initial triangulation of  $(S, M)$ .

### 2.1.5 Laurent Phenomenon and positivity

Given countably many indeterminates  $X_1, X_2, X_3, \dots$  a Laurent polynomial over a field (or a ring)  $\mathbb{F}$  is a polynomial in  $X_1, X_2, X_3, \dots, X_1^{-1}, X_2^{-1}, X_3^{-1}, \dots$ . Now, let us consider the following examples.

**Example 2.18.** Consider the seed

$$\Sigma = (\{x_1, x_2\}, x_1 \longrightarrow x_2).$$

By mutating  $\Sigma$  at  $x_1$  we get the seed

$$\Sigma' = (\{x'_1, x_2\}, x'_1 \longleftarrow x_2),$$

where  $x'_1 = \mu_{x_1, \Sigma}(x_1) = \frac{x_2+1}{x_1}$ . Then mutating the seed  $\Sigma'$  at  $x_2$  we obtain the seed

$$\Sigma'' = (\{x'_1, x'_2\}, x'_1 \longrightarrow x'_2),$$

where  $x'_2 = \mu_{x_2, \Sigma'}(x_2) = \frac{x'_1+1}{x_2} = \frac{x_1+x_2+1}{x_1x_2}$ . Finally, mutating the seed  $\Sigma''$  at  $x'_1$  we obtain the seed

$$\Sigma''' = (\{x''_1, x'_2\}, x''_1 \longleftarrow x'_2),$$

where

$$x''_1 = \mu_{x'_1, \Sigma''}(x'_1) = \frac{\frac{x_1+x_2+1}{x_1x_2} + 1}{\frac{x_2+1}{x_1}},$$

which, surprisingly, then reduces to a simple Laurent polynomial in  $x_1$  and  $x_2$  as follows:

$$\frac{\frac{x_1+x_2+1}{x_1x_2} + 1}{\frac{x_2+1}{x_1}} = \frac{x_1 + x_2 + 1 + x_1x_2}{x_1x_2} \frac{x_1}{x_2 + 1} = \frac{(x_2 + 1)(x_1 + 1)}{x_1x_2} \frac{x_1}{x_2 + 1} = \frac{x_1 + 1}{x_2}.$$

In fact, the cluster variables  $x'_1, x'_2$  and  $x''_1$  are the only cluster variables that we can obtain from  $\Sigma$  in finitely many mutation steps and so

$$\mathcal{A}(\Sigma) = \mathbb{Z}[x_1, x_2, x'_1, x'_2, x''_1].$$

**Example 2.19.** Consider the seed

$$\Sigma = (\{x_1, x_2, x_3\}, x_1 \longrightarrow x_2 \longleftarrow x_3).$$

Then

$$\mathcal{X}_\Sigma = \left\{ x_1, x_2, x_3, \frac{x_2 + 1}{x_1}, \frac{x_1 x_3 + 1}{x_2}, \frac{x_2 + 1}{x_3}, \frac{x_1 x_3 + x_2 + 1}{x_1 x_2}, \frac{x_1 x_3 + x_2 + 1}{x_2 x_3}, \frac{x_1 x_3 + (x_2 + 1)^2}{x_1 x_2 x_3} \right\}$$

and

$$\mathcal{A}(\Sigma) = \mathbb{Z}[\mathcal{X}_\Sigma].$$

Note that we can regard  $\mathcal{A}(\Sigma)$  as a cluster algebra associated to a hexagon. This is done in the following way. Let  $T$  be the following triangulation of a hexagon and let  $\Sigma_T$  be the

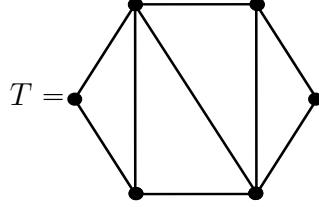

corresponding seed. We can then recover the cluster algebra  $\mathcal{A}(\Sigma)$  from  $\mathcal{A}(\Sigma_T)$  by adapting the convention that if  $x$  and  $y$  are consecutive marked points of a hexagon then  $x_{\{x,y\}} = 1$  in  $\mathcal{A}(\Sigma_T)$ .

We notice again that all cluster variables in Examples 2.18 and 2.19 above, a priori rational functions, are in fact Laurent polynomials in the elements from their respective initial clusters. This is a special case of the following remarkable result, known as *Laurent phenomenon*.

**Theorem 2.20.** ([16, Theorem 3.1]). *Let  $\Sigma = (X, ex, B)$  be a seed. Then any element of  $\mathcal{X}_\Sigma$  can be written as a Laurent polynomial in  $ex$  with coefficients which are integer polynomials in  $X \setminus ex$ .*

Now, if we again look at the cluster variables from the examples above we notice that they not only are Laurent polynomials in  $x_1, x_2$  and in  $x_1, x_2, x_3$ , respectively, but in fact they are also minus-free rational functions. The *positivity conjecture* claims that cluster variables, in any given cluster algebra, are always minus-free. That conjecture has been proven for many important cases: for all skew-symmetric cluster algebras of finite rank by Lee and Schiffler [29], for cluster algebras from surfaces by Musiker, Schiffler and Williams [33], for acyclic cluster algebras by Kimura and Qin [28] and for skew-symmetric cluster algebras of infinite rank by Gratz [22].

## 3 Classification of finite type cluster algebras

Let us start this section with the following definition.

**Definition 3.1.** Let  $\Sigma$  be a seed and  $\text{Mut}(\Sigma)$  its corresponding mutation class. We say that the cluster algebra  $\mathcal{A}(\Sigma)$  (respectively the rooted cluster algebra  $(\mathcal{A}(\Sigma), \Sigma)$ ) is of *finite type* if  $\text{Mut}(\Sigma)$  is finite.

In this section we will be working towards classifying the cluster algebras of finite type. Remarkably, this is done in terms of finite type Dynkin diagrams. Thus, before we dive into the classification of (finite type) cluster algebras, we first provide some preliminaries on the theory of finite (crystallographic) reflection groups and their classification. This background section as well as Section 3.2 follow very closely the exposition written by Marsh in [32, §4, 5].

### 3.1 Finite reflection groups

#### 3.1.1 Definition of a reflection group.

For the remainder of this chapter,  $n$  is a natural number and  $I = \{1, \dots, n\}$ . (In most cases,  $I$  is the set of nodes in the Dynkin diagram, unless stated otherwise).

Throughout this chapter a vector space  $V$  is always defined over the real numbers. We call  $V$  a *Euclidean space* if there is a bilinear map  $(-, -) : V \times V \rightarrow \mathbb{R}$  which in addition satisfies the following two conditions:

- *symmetry*:  $(\alpha, \beta) = (\beta, \alpha)$  for all  $\alpha, \beta \in V$ ;
- *positive definiteness*:  $(\alpha, \alpha) > 0$  for all nonzero  $\alpha \in V$ .

The vector space  $\mathbb{R}^n$  equipped with the usual dot product is an example of a Euclidean space.

Let us assume that from now on  $V$  is a Euclidean space. We fix vectors  $\alpha, \beta \in V$  and denote by  $\mathbb{R}\alpha$  the span of a vector  $\alpha$ , which is a subspace of  $V$ . Vectors in  $V$  have lengths and directions. The *length*  $|\alpha|$  of a vector  $\alpha$  is given by  $\sqrt{(\alpha, \alpha)}$  and the angle  $\theta$  between vectors  $\alpha$  and  $\beta$  is given by  $(\alpha, \beta) = |\alpha||\beta| \cos \theta$ . If an angle  $\theta$  between vectors  $\alpha$  and  $\beta$  equals  $\frac{\pi}{2}$ , then we say that  $\alpha$  and  $\beta$  are *orthogonal*. A linear map  $T : V \rightarrow V$  on  $V$  is called

an *orthogonal transformation* if it preserves  $(-, -)$ , that is, if  $(T(\alpha), T(\beta)) = (\alpha, \beta)$  for all  $\alpha, \beta$ . A set of all orthogonal linear transformations on  $V$  together with the operation of composition of linear transformations forms the group  $O(V)$ , called the *orthogonal group*. If  $V'$  is another Euclidean space with bilinear map  $(-, -)'$ , and if  $T : V \rightarrow V'$  is a linear transformation such that  $(T(\alpha), T(\beta))' = (\alpha, \beta)$  for all  $\alpha, \beta$ , then we call a constant multiple of such map a *similarity* (see [32, Section 4.1]).

In this section, we focus on a certain subgroup of  $O(V)$ , which is generated by so-called reflections.

**Definition 3.2.** ([32, Definition 4.1.1]). A *reflection* on  $V$  is a linear map  $s : V \rightarrow V$  such that

- (a)  $s$  fixes a hyperplane pointwise,
- (b)  $s$  reverses the direction of any normal vector to the hyperplane.

We will only consider hyperplanes of the form:

$$H_\alpha = \{v \in V : (\alpha, v) = 0\},$$

for some vector  $\alpha$ . One can deduce from the properties of  $(-, -)$  that the zero vector is always in  $H_\alpha$ , for every choice of  $\alpha$ . Moreover, for any  $c \in \mathbb{R} \setminus \{0\}$ , we have that  $H_\alpha = H_{c\alpha}$ .

As it turns out, there is a nice and simple formula for a reflection.

**Lemma 3.3.** *The formula for a reflection  $s_\alpha$  in the hyperplane  $H_\alpha$  is given by  $s_\alpha(\beta) = \beta - \frac{2(\alpha, \beta)\alpha}{(\alpha, \alpha)}$ .*

*Proof.* First, let  $\beta \in H_\alpha$ . Then

$$s_\alpha(\beta) = \beta - \frac{2(\alpha, \beta)\alpha}{(\alpha, \alpha)} = \beta - \mathbf{0} = \beta.$$

Next if  $\beta = \alpha$  then

$$s_\alpha(\alpha) = \alpha - \frac{2(\alpha, \alpha)\alpha}{(\alpha, \alpha)} = \alpha - 2\alpha = -\alpha.$$

Now the result follows from the fact that  $V = \mathbb{R}\alpha \oplus H_\alpha$  (see [32, Lemma 4.1.1]) and that both  $s_\alpha$  and the formula given in the statement of the lemma are linear.  $\square$

We notice that because  $H_\alpha = H_{c\alpha}$ , for any non-zero real number  $c$ , we have that  $s_\alpha = s_{c\alpha}$ .

One of the main aims of this chapter is to investigate subgroups of orthogonal groups which are generated by reflections. First, let us show that reflections are indeed orthogonal transformations.

**Lemma 3.4.** *The reflection  $s_\alpha$  in the hyperplane  $H_\alpha$  is an orthogonal transformation.*

*Proof.* To prove the orthogonality we make use of the formula from Lemma 3.3. Let  $\beta, \beta' \in V$ .

We have

$$\begin{aligned} (s_\alpha(\beta), s_\alpha(\beta')) &= \left( \beta - \frac{2(\alpha, \beta)\alpha}{(\alpha, \alpha)}, \beta' - \frac{2(\alpha, \beta')\alpha}{(\alpha, \alpha)} \right) \\ &= (\beta, \beta') - \frac{4(\alpha, \beta)}{(\alpha, \beta')}(\alpha, \alpha) + \frac{4(\alpha, \beta')}{(\alpha, \beta')}(\alpha, \alpha) \\ &= (\beta, \beta'), \end{aligned}$$

as required. □

We are now in the position to give a formal definition of a reflection group.

**Definition 3.5.** ([25, Section 1.1]). A *reflection group* is a subgroup of the orthogonal group  $O(V)$  generated by reflections.

**Example 3.6.** Let  $V = \mathbb{R}^n$  equipped with the usual dot product and with the natural basis  $e_1, \dots, e_n$ . The symmetric group  $S_n$  can be thought of as a subgroup of the orthogonal group  $O(V)$  in the following way. A permutation  $\sigma \in S_n$  induces a linear map  $f_\sigma : V \rightarrow V$  which sends  $\sum_{i=1}^n \lambda_i e_i$  to  $\sum_{i=1}^n \lambda_i e_{\sigma(i)}$  and clearly preserves the dot-product. In other words,  $f_\sigma \in O(V)$  for all  $\sigma \in S_n$ . Now, let  $\sigma = (i, j) \in S_n$  be a transposition. Then  $f_\sigma(e_i - e_j) = e_j - e_i = -(e_i - e_j)$  and so  $f_\sigma$  sends the vector  $e_i - e_j$  to its negative. Moreover, we have

$$\begin{aligned} H_{e_i - e_j} &= \left\{ \sum_{i=1}^n \lambda_i e_i \in V \mid (e_i - e_j, \sum_{i=1}^n \lambda_i e_i) = 0 \right\} \\ &= \left\{ \sum_{i=1}^n \lambda_i e_i \in V \mid \lambda_i = \lambda_j \right\} \end{aligned}$$

and so clearly for any  $v \in H_{e_i - e_j}$  we have that  $f_\sigma(v) = v$ . Thus we have shown that every orthogonal transformation induced by a transposition  $(i, j) \in S_n$  is in fact a reflection and



since  $S_n$  is generated by transpositions, it is a reflection group, when seen in this way. In fact, it is already generated by the transpositions  $(i, i + 1)$ ,  $1 \leq i < n$ .

Over the next few sections we will work towards classifying all finite reflection groups.

### 3.1.2 Root systems

To any given finite reflection group, which we will denote by  $W$  from now on, we will attach a set of vectors, a so-called *root system*, from the underlying Euclidean space  $V$ .

Fix  $W$ . Every reflection  $s_\alpha \in W$  has a hyperplane  $H_\alpha$  associated to it and a line spanned by  $\alpha$ , perpendicular to  $H_\alpha$ . We denote by  $L_W$  the set of all such lines. That is,

$$L_W = \{\mathbb{R}\alpha \mid s_\alpha \in W\}.$$

As it turns out, if  $\mathbb{R}\alpha \in L_W$  and  $w \in W$  then  $\mathbb{R}w\alpha \in L_W$  also.

**Lemma 3.7.** ([25, Section 1.2]). *The set  $L_W$  is closed under the action of  $W$ .*

Now let  $\Phi_W = \{\beta \in \mathbb{R}\alpha \mid s_\alpha \in W, |\beta| = 1\}$ . In words,  $\Phi_W$  is the set of unit vectors in the lines from  $L_W$  with every line contributing two unit vectors to  $\Phi_W$ . Immediately, because  $W$  is finite and so there are finitely many reflections in  $W$ , we have that  $\Phi_W$  is also finite. Moreover, if we let  $\alpha, \beta \in \Phi_W$ , then  $\mathbb{R}s_\alpha(\beta) \in L_W$ , by Lemma 3.7. Now  $s_\alpha \in W$  and so it preserves the lengths of the vectors. Therefore, since  $\beta$  is the unit vector then so is  $s_\alpha(\beta)$  and so  $s_\alpha(\beta) \in \Phi_W$ . Yet further, we have, as a direct consequence of the definition of  $\Phi_W$ , that  $\mathbb{R}\alpha \cap \Phi_W = \{\pm\alpha\}$ . These observations motivate the following definition.

**Definition 3.8.** ([25, Section 1.2]). A finite subset  $\Phi$  of nonzero vectors of  $V$  is called a *root system* if it satisfies the conditions:

1. For all  $\alpha \in \Phi$ ,  $\mathbb{R}\alpha \cap \Phi = \{\pm\alpha\}$ .
2. For all  $\alpha, \beta \in \Phi$ ,  $s_\alpha(\beta) \in \Phi$ .

Two root systems  $\Phi \subseteq V$  and  $\Phi' \subseteq V'$ , for some Euclidean spaces  $V$  and  $V'$ , are *isomorphic*, if there is a similarity from  $T : V \rightarrow V'$  such that  $T(\Phi) = \Phi'$  (see [32, Definition 4.2.5]).

**Example 3.9.** Let  $V = \mathbb{R}^n$  equipped with the usual dot product and with the natural basis  $e_1, \dots, e_n$ . Then the subset  $\Phi$  of  $V$  given by

$$\Phi = \{e_i - e_j : 1 \leq i, j \leq n, i \neq j\}$$

is a root system in  $V$ .

**Remark 3.10.** We notice a small discrepancy between the root system  $\Phi_W$  we constructed for an arbitrary reflection group  $W$  and the definition of a root system. Namely, the vectors in  $\Phi_W$  were the unit vectors, whereas the vectors in an arbitrary root system  $\Phi$  need not to be unit vectors, as we saw in the Example 3.9 above.

Therefore, to any finite reflection group  $W$  we can attach a root system  $\Phi_W$  constructed in the way explained above. Going in the opposite direction, we can associate to any root system  $\Phi \subseteq V$  a finite reflection group.

**Lemma 3.11.** ([25, Section 1.2]). *Let  $\Phi$  be a root system. Then*

$$W_\Phi = \langle s_\alpha \mid \alpha \in \Phi \rangle$$

*is a finite reflection group.*

We say that a root system is *irreducible* if it does not arise as the union of two root systems that are orthogonal subsets of  $V$ . We call  $W = W_\Phi$  an *irreducible* reflection group if it arises from an irreducible root system  $\Phi$ .

We also have that

$$W = \langle s_\alpha \mid \mathbb{R}\alpha \in L_W \rangle = \langle s_\alpha \mid \alpha \in \Phi_W \rangle = W_{\Phi_W}.$$

Therefore, not only does any root system  $\Phi \subseteq V$  gives rise to a finite reflection group, but also any finite reflection group  $W$  arises from a root system, namely the root system  $\Phi_W$ , in the way explained above.

We finish this section with the following definition.

**Definition 3.12.** ([25, Section 2.9]). We call a root system  $\Phi$  *crystallographic* if  $\frac{2(\alpha, \beta)}{(\alpha, \alpha)} \in \mathbb{Z}$  for all  $\alpha, \beta \in \Phi$ .

If a reflection group  $W$  arises from a crystallographic root system  $\Phi$ , that is if  $W = W_\Phi$  for  $\Phi$  a crystallographic root system, then we say that  $W$  is a crystallographic reflection group or, as it is often named in literature, a *Weyl group*.

### 3.1.3 Simple systems and Cartan matrices

Let us start this section with an example.

**Example 3.13.** Let  $V = \mathbb{R}^3$  equipped with the usual dot product and with the natural basis  $e_1, e_2, e_3$ . Then by Example 3.9 the subset

$$\Phi := \{(1, -1, 0), (0, 1, -1), (1, 0, -1), (-1, 1, 0), (-1, 0, 1), (0, -1, 1)\} \subset V$$

is a root system. Now let  $\alpha_1 = (1, -1, 0)$  and  $\alpha_2 = (0, 1, -1)$ . Then  $(-1, 1, 0) = -\alpha_1$  and  $(0, -1, 1) = -\alpha_2$ . Moreover,  $(1, 0, -1) = \alpha_1 + \alpha_2$  and  $(-1, 0, 1) = -\alpha_1 - \alpha_2$ . Thus, we can see that every vector from  $\Phi$  can be written as either a nonnegative or a nonpositive linear combination of  $\alpha_1$  and  $\alpha_2$ .

**Definition 3.14.** ([25, Section 1.3]). The subset  $\Delta \subseteq \Phi$  of a root system is called a *simple system* if it is a basis of  $\text{span}(\Phi)$  and satisfies the following property:

- Each  $\alpha \in \Phi$  is a linear combination of elements of  $\Delta$  with integer coefficients that are either all nonnegative or nonpositive.

A simple system for a given root system is not unique. In Example 3.13 above,  $\Delta = \{\alpha_1, \alpha_2\}$  is a simple system. But we can also take  $\Delta' = \{\beta_1 := (1, 0, -1), \beta_2 := (-1, 1, 0)\}$ . Then  $\Delta'$  is also a simple system:

$$(-1, 0, 1) = -\beta_1, (1, -1, 0) = -\beta_2, (0, 1, -1) = \beta_1 + \beta_2, (0, -1, 1) = -\beta_1 - \beta_2.$$

Given a simple system  $\Delta \subseteq \Phi$  of a root system we refer to its elements as *simple roots*, and to the corresponding reflections as *simple reflections*. The *rank* of a root system  $\Phi$  is defined to be the cardinality of a subset  $\Delta \subseteq \Phi$  of simple roots (this is well-defined as every root system has a simple system, see Theorem 3.15 for more details). A vector  $\alpha \in \Phi$  is called a *positive root* (respectively, a *negative root*) if it can be written as a linear combination of

elements of  $\Delta$  with nonnegative (respectively, nonpositive) integer coefficients. We denote by  $\Phi_+$  (respectively, by  $\Phi_-$ ) the subset of  $\Phi$  consisting of all positive roots (respectively, all negative roots) with respect to  $\Delta$ .

In Example 3.13 we considered a root system

$$\Phi = \{\alpha_1, \alpha_2, \alpha_1 + \alpha_2, -\alpha_1, -\alpha_2, -\alpha_1 - \alpha_2\} \subset \mathbb{R}^3.$$

The corresponding reflection group is

$$W_\Phi = \langle s_\alpha \mid \alpha \in \Phi \rangle.$$

We notice that by acting with certain elements of  $W_\Phi$  on a simple root  $\alpha_1$  we can reach every vector in  $\Phi$ . We have of course that  $s_{\alpha_1}(\alpha_1) = -\alpha_1$  and that  $s_{\alpha_1}s_{\alpha_1}(\alpha_1) = \alpha_1$ . Moreover,  $s_{\alpha_1+\alpha_2}(\alpha_1) = -\alpha_2$  and  $s_{\alpha_1}s_{\alpha_1+\alpha_2}(\alpha_1) = -\alpha_1 - \alpha_2$  and finally  $s_{\alpha_2}(\alpha_1) = \alpha_1 + \alpha_2$  and  $s_{-\alpha_1}s_{\alpha_2}(\alpha_1) = \alpha_2$ . This is a special case of statement in part (d) in the following theorem.

**Theorem 3.15.** ([32, Theorem 4.3.1], [25, Sections 1.3-1.8]). *Let  $\Phi$  be a root system. Then*

- (a)  $\Phi$  has a simple system,  $\Delta$ .
- (b) If  $\Phi_+$  and  $\Phi_-$  are the corresponding subsets of positive and negative roots, then  $\Phi_- = -\Phi_+$ .
- (c) The group  $W_\Phi$  acts simply transitively on the simple systems in  $\Phi$ .
- (d) Every root in  $\Phi$  lies in the  $W_\Phi$ -orbit of a simple root.

For  $s_\alpha, s_\beta \in W$  we denote by  $m(\alpha, \beta) \in \mathbb{N}$  the order of the product  $s_\alpha s_\beta$  in  $W$ . In particular, if  $W = W_\Phi$  for a root system  $\Phi$  with a simple system  $\Delta$ , we denote by  $m(i, j) \in \mathbb{N}$  the order of the product  $s_{\alpha_i} s_{\alpha_j}$  in  $W$ , where  $\alpha_i, \alpha_j \in \Delta$ . If  $W = W_\Phi$  is crystallographic, then  $m(i, j) \in \{1, 2, 3, 4, 6\}$  (see e.g. [25, Section 2.8]).

Recall that  $I = \{1, \dots, n\}$ ,  $n \in \mathbb{N}$ .

**Definition 3.16.** ([25, Section 2.9]). Let  $\Phi$  be a crystallographic root system with a simple system  $\{\alpha_i \mid i \in I\}$ . The *Cartan matrix* of  $\Phi$  is the integer matrix  $A = (a_{ij})$ , where  $a_{ij} = \frac{2(\alpha_i, \alpha_j)}{(\alpha_i, \alpha_i)}$  for all  $i, j \in I$ .

The integers  $a_{ij}$  in the above definition are often called *Cartan integers*.

Now let  $\Delta = \{\alpha_i \mid i \in I\}$ ,  $\Delta' = \{\alpha'_i \mid i \in I\}$  be simple systems of a (crystallographic) root system  $\Phi$ . Then by Theorem 3.15(c) there exists  $w \in W = W_\Phi$  such that  $w(\Delta) = \Delta'$  and we can assume that  $w(\alpha_i) = \alpha'_i$  for all  $i \in I$ . Since  $w \in O(V)$  we have that

$$\frac{2(\alpha_i, \alpha_j)}{(\alpha_i, \alpha_i)} = \frac{2(\alpha'_i, \alpha'_j)}{(\alpha'_i, \alpha'_i)}$$

and so the Cartan matrices corresponding to  $\Delta$  and  $\Delta'$  are the same, up to a simultaneous reordering of rows and columns. Now going in the other direction, we have that the Cartan matrix determines the root system up to isomorphism:

**Proposition 3.17.** (*[32, Proposition 4.5.2]*). *Let  $\Phi \subseteq V = \text{span}(\Phi)$  and  $\Phi' \subseteq V' = \text{span}(\Phi')$  be irreducible crystallographic root systems with the same Cartan matrix up to simultaneous permutation of rows and columns. Then  $\Phi \cong \Phi'$ .*

We can yet say more about Cartan matrices.

**Proposition 3.18.** *Let  $\Phi$  be a crystallographic root system with a simple system  $\Delta = \{\alpha_1, \dots, \alpha_n\}$  and  $A$  the Cartan matrix of  $\Phi$ . Then*

- (a) *For all  $i \in I$ ,  $a_{ii} = 2$ ;*
- (b) *For all  $i \neq j$  in  $I$ ,  $a_{ij} \in \{0, -1, -2, -3\}$ ;*
- (c) *For all  $i \neq j$  in  $I$ ,  $a_{ij} = 0$  if and only if  $a_{ji} = 0$ ;*
- (d) *For all  $i \neq j$  in  $I$ , if  $a_{ij} = -2$  or  $-3$  then  $a_{ji} = -1$ ;*
- (e) *All the principal minors of  $A$  have positive determinant;*
- (f)  *$A$  is symmetrizable.*

*Proof.* Properties (a) and (c) are clear. For (b) and (d) we argue as follows. Let  $\alpha_i, \alpha_j \in \Delta$  and let  $\theta$  be the angle between  $\alpha_i$  and  $\alpha_j$ . We have

$$(\alpha_i, \alpha_j) = |\alpha_i||\alpha_j| \cos \theta,$$

where  $\alpha_i = \sqrt{(\alpha_i, \alpha_i)}$  for all  $i \in I$ . Hence

$$4 \cos^2 \theta = \frac{2(\alpha_i, \alpha_j)}{(\alpha_i, \alpha_i)} \frac{2(\alpha_j, \alpha_i)}{(\alpha_j, \alpha_j)} = a_{ij} a_{ji}.$$

Now the possible values for  $\theta$  are  $\frac{\pi}{2}, \frac{2\pi}{3}, \frac{3\pi}{4}$  and  $\frac{5\pi}{6}$  and so the possible values for  $\cos(\theta)$  are  $0, -\frac{1}{2}, -\frac{\sqrt{2}}{2}$  and  $-\frac{\sqrt{3}}{2}$ , respectively (see ([11, Section 6.1])). Thus  $a_{ij} \leq 0$  for all  $i, j \in I$  such that  $i \neq j$ . If  $\theta = \frac{\pi}{2}$  then  $a_{ij} = a_{ji} = 0$ ; if  $\theta = \frac{2\pi}{3}$  then  $1 = a_{ij} a_{ji}$  and so  $a_{ij} = a_{ji} = -1$ ; if  $\theta = \frac{3\pi}{4}$  then  $2 = a_{ij} a_{ji}$  and either  $a_{ij} = -1$  and  $a_{ji} = -2$  or  $a_{ij} = -2$  and  $a_{ji} = -1$ ; finally, if  $\theta = \frac{5\pi}{6}$  then  $3 = a_{ij} a_{ji}$  and either  $a_{ij} = -1$  and  $a_{ji} = -3$  or  $a_{ij} = -3$  and  $a_{ji} = -1$  and we are done.

For (e) and (f) see Lemma 4.6 and Proposition 4.7 in [26], respectively.  $\square$

In fact, the conditions (a) – (f) from Proposition 3.18 characterize Cartan matrices of crystallographic root systems (see [26, Proposition 4.7]). Matrices that satisfy the conditions (a) – (f) are often referred to as Cartan matrices of *finite type*.

### 3.1.4 Coxeter groups

In Example 3.6 we explained how the symmetric group  $S_n$  can be seen as a reflection group. The symmetric group  $S_n$  is generated by the transpositions  $\sigma_i := (i, i + 1)$ ,  $1 \leq i < n$ , that satisfy the following relations:

- $\sigma_i^2 = e$  and  $(\sigma_i \sigma_{i+1})^3 = e$  for all  $i \in I$ ;
- $\sigma_i \sigma_j = \sigma_j \sigma_i$ , for all  $i, j \in I$  such that  $|i - j| > 1$ .

. In other words, the group  $S_n$  admits the presentation

$$\langle \sigma_i : i \in I \mid \sigma_i^2 = e, (\sigma_i \sigma_{i+1})^3 = e, (\sigma_i \sigma_j)^2 = e, \text{ for all } i, j \in I \text{ such that } |i - j| > 1 \rangle.$$

This implies that the symmetric group  $S_n$  is an example of a so-called *Coxeter group*.

**Definition 3.19.** ([32, Section 4.4]). Let  $\Phi$  be a root system and  $\Delta = \{\alpha_i \mid i \in I\} \subseteq \Phi$  its simple system. A group  $W$  is said to be a *Coxeter group* if it has a presentation of the form

$$W = \langle s_{\alpha_i} : i \in I \mid (s_{\alpha_i} s_{\alpha_j})^{m_{ij}} = e, \text{ for all } i, j \in I \rangle,$$

where  $m_{ii} = 1$  for all  $i \in I$  and for all  $i \neq j$  in  $I$ ,  $m_{ij} = m_{ji}$  is either an integer which is at least 2 or  $m_{ij} = \infty$ , meaning the absence of a relation.

**Theorem 3.20.** ([32, Sections 1.9, 6.4]). Let  $\Phi$  be a root system and  $\Delta = \{\alpha_1, \dots, \alpha_n\} \subseteq \Phi$  a simple system of  $\Phi$ . Then  $W_\Phi$  is a Coxeter group with presentation

$$W_\Phi = \langle s_{\alpha_1}, \dots, s_{\alpha_n} \mid (s_{\alpha_i} s_{\alpha_j})^{m(i,j)} = e, \text{ for all } i, j \in I \rangle.$$

Moreover, all finite Coxeter groups are precisely the finite reflection groups.

### 3.1.5 Dynkin diagram and classification of finite crystallographic reflection groups

We introduce a way of recording a Cartan matrix as a graph.

**Definition 3.21.** ([32, Section 4.6]). Let  $\Phi$  be a crystallographic root system,  $\Delta = \{\alpha_1, \dots, \alpha_n\} \subseteq \Phi$  a simple system and  $A = (a_{ij})_{1 \leq i, j \leq n}$  the corresponding Cartan matrix. The *Dynkin diagram*  $\Gamma$  of  $\Phi$  is a graph with vertices  $1, \dots, n$  with  $a_{ij}a_{ji}$  edges between them. Moreover, if  $(\alpha_i, \alpha_i) > (\alpha_j, \alpha_j)$  then we draw an arrow from vertex  $i$  to vertex  $j$ .

We note that  $a_{ij}a_{ji} \in \{0, 1, 2, 3\}$  for all  $i \neq j$ , which follows from Proposition 3.18. Moreover, if  $(\alpha_i, \alpha_i) > (\alpha_j, \alpha_j)$  then  $a_{ij} = \frac{2(\alpha_i, \alpha_j)}{(\alpha_i, \alpha_i)} > \frac{2(\alpha_j, \alpha_i)}{(\alpha_j, \alpha_j)} = a_{ji}$  and so  $a_{ij} = -1$  and  $a_{ji} = -2$  or  $-3$ , again, by Proposition 3.18. Thus informally, if  $\alpha_i$  is *larger* than  $\alpha_j$ , then there are multiple edges between  $i$  and  $j$  in  $\Gamma$ .

With Proposition 3.18 at hand, one can easily recover the Cartan matrix from the Dynkin diagram. Let us consider an example.

**Example 3.22.** Let us suppose that we are given the Cartan matrix  $A = (a_{ij})_{i, j \in \{1, 2, 3, 4\}}$  that gives rise to the following Dynkin diagram

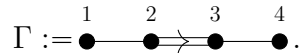

From  $\Gamma$  we want to recover the entire  $a_{ij}$  of  $A$  for all  $i, j \in \{1, 2, 3, 4\}$ . First, there is a single edge between the vertices 1 and 2 and so  $a_{12}a_{21} = 1$ . We have by Proposition 3.18 that  $a_{ij} \in \{0, -1, -2, -3\}$  for all  $i \neq j$  in  $\{1, 2, 3, 4\}$  and so  $a_{12} = a_{21} = -1$ . Via the same argument, we have that  $a_{34} = a_{43} = -1$ . Now there are two edges between the vertices 3 and 4 and so  $a_{23}a_{32} = 2$ . Again since  $a_{ij} \in \{0, -1, -2, -3\}$  for all  $i \neq j$  in  $\{1, 2, 3, 4\}$ , there are two possibilities. Either  $a_{23} = -2$  and  $a_{32} = -1$  or  $a_{23} = -1$  and  $a_{32} = -2$ . Now because an arrow goes from vertex 2 to vertex 3, we have that  $a_{23}$  is strictly greater than  $a_{32}$  and

so  $a_{23} = -1$  and  $a_{32} = -2$ . Next, because there are no edges between vertices 1 and 3, 1 and 4 and 2 and 4 and because  $a_{ij} = 0$  if and only if  $a_{ji} = 0$  for all  $i \neq j$  in  $\{1, 2, 3, 4\}$  (this is, again, Proposition 3.18), we have that  $a_{13} = a_{31} = a_{14} = a_{41} = a_{24} = a_{42} = 0$ . Finally,  $a_{ii} = 2$  for all  $i \in \{1, 2, 3, 4\}$ . Putting everything together, we get that the Cartan matrix  $A$  is

$$\begin{pmatrix} 2 & -1 & 0 & 0 \\ -1 & 2 & -1 & 0 \\ 0 & -2 & 2 & -1 \\ 0 & 0 & -1 & 2 \end{pmatrix}.$$

It is easy to see that the Dynkin diagram of a crystallographic root system with Cartan matrix  $A$  is indeed given by  $\Gamma$ . More generally, the same procedure can be extended and used for any given Dynkin diagram.

Before we state the main theorem of this section, let us tidy things up a little. So far, to every crystallographic root system we attached a Cartan matrix (unique up to a simultaneous reordering rows and columns) from which we then constructed the Dynkin diagram (unique up to relabelling vertices). Going in the opposite direction, we saw that the Dynkin diagram determines the Cartan matrix and that the Cartan matrix determines the crystallographic root system, up to isomorphism (Proposition 3.17). We have by [32, Lemma 4.2.6] that if root systems  $\Phi$  and  $\Phi'$  are isomorphic then so are their associated reflection groups. The following theorem then completes the picture.

**Theorem 3.23.** ([24, §11]). *The Dynkin diagram of the irreducible crystallographic root systems are those in the following list.*

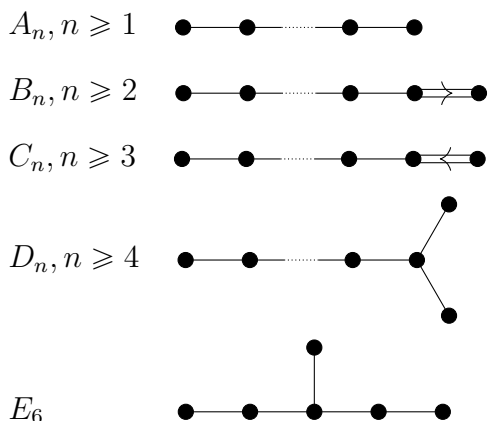



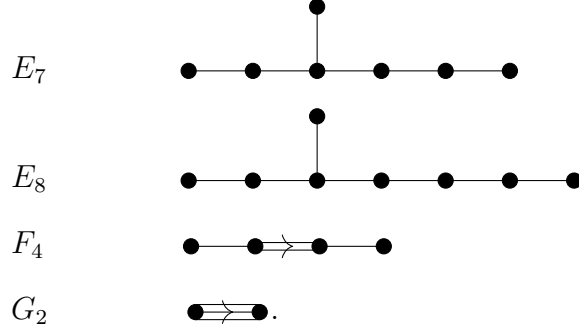

In Table 1 we give the explicit construction of the irreducible crystallographic root systems of types  $A_n, B_n, C_n$  and  $D_n$  and the structure of their corresponding Weyl groups. The vector space  $\mathbb{R}^n$  is given the structure of a Euclidean space via the usual dot product. Every subspace of  $\mathbb{R}^n$  together with the dot product is also a Euclidean space. To make Table 1. easier to read, we introduce the following notation. Let  $e_1, \dots, e_n$  be the natural basis of  $\mathbb{R}^n$ . Then let

$$\Delta_n = \{e_i - e_{i+1}, 1 \leq i \leq n\}$$

and

$$\mathbf{e}_{>}^n = \{\pm e_i \pm e_j : 1 \leq i < j \leq n\},$$

where whenever we write  $\pm e_i \pm e_j$ , it means that the sign may be chosen arbitrarily. For more details on the construction of the root systems of types  $A_n, B_n, C_n$  and  $D_n$  and their corresponding Weyl groups we refer the reader to [25, §2], [24, §11-12] and references therein. Details about the root systems of types  $E_{6,7,9}, F_4$  and  $G_2$  (and their reflection groups) can also be found there.

Type	Euclidean space	Crystallographic root system	Simple system	Weyl group
$A_n, n \geq 1$	$\{\sum_{i=1}^{n+1} \lambda_i e_i : \sum_{i=1}^{n+1} \lambda_i = 0\}$	$\{e_i - e_j : 1 \leq i \neq j \leq n+1\}$	$\Delta_n$	$S_{n+1}$
$B_n, n \geq 2$	$\mathbb{R}^n$	$\{\pm e_i, 1 \leq i \leq n\} \cup \mathbf{e}_{>}^n$	$\Delta_{n-1} \cup \{e_n\}$	$(\mathbb{Z}/2\mathbb{Z})^n \times S_n$
$C_n, n \geq 3$	$\mathbb{R}^n$	$\{\pm 2e_i, 1 \leq i \leq n\} \cup \mathbf{e}_{>}^n$	$\Delta_{n-1} \cup \{2e_n\}$	$(\mathbb{Z}/2\mathbb{Z})^n \times S_n$
$D_n, n \geq 4$	$\mathbb{R}^n$	$\mathbf{e}_{>}^n$	$\Delta_{n-1} \cup \{e_{n-1} + e_n\}$	$(\mathbb{Z}/2\mathbb{Z})^{n-1} \times S_n$

Table 1: Concrete examples of root systems of types  $A_n, B_n, C_n, D_n$  and their corresponding Weyl groups.

## 3.2 Classification of finite type cluster algebras

We are now almost ready for the classification theorem. The last two pieces of notation that we are going to need are the following. If  $B \in M_I(\mathbb{Z})$  is an integer matrix, its *Cartan counterpart*  $A$  is the integer matrix  $A = A(B) = (a_{ij})_{i,j \in I} \in M_I(\mathbb{Z})$  where

$$a_{ij} = \begin{cases} 2 & \text{if } i = j; \\ -|b_{ij}| & \text{if } i \neq j. \end{cases}$$

**Definition 3.24.** ([32, Definition 2.2.1]). Let  $\Sigma = (X, ex, B)$  be a seed. We call the matrix  $\tilde{B} = B[ex] \in M_{ex}(\mathbb{Z})$  the *principal part* of  $B$ .

Finally, we have:

**Theorem 3.25.** ([17, Theorem 1.4]). Let  $\Sigma = (X, ex, B)$  be a seed. A cluster algebra  $\mathcal{A}(\Sigma)$  (respectively a rooted cluster algebra  $(\mathcal{A}(\Sigma), \Sigma)$ ) is of finite type if and only if there exists a seed  $\Sigma' = (X', ex', B') \in \text{Mut}(\Sigma)$  such that  $A(\tilde{B}')$  is a Cartan matrix of finite type (cf. page 30).

For a skew-symmetric matrix  $B$  we may restate the above theorem in the language of quivers. Recall that the underlying graph of the quiver  $Q_B$  is a graph which is obtained from  $Q_B$  after forgetting the orientation of arrows.

**Theorem 3.26.** ([17, Theorem 1.4]). Let  $\Sigma = (X, ex, Q_B)$  be a seed. A cluster algebra  $\mathcal{A}(\Sigma)$  (respectively a rooted cluster algebra  $(\mathcal{A}(\Sigma), \Sigma)$ ) is of finite type if and only if there exists a seed  $\Sigma' = (X', ex', Q_{B'}) \in \text{Mut}(\Sigma)$  such that the underlying graph of  $Q_{B'}$  is a Dynkin diagram.

**Remark 3.27.** We note that in Theorem 3.25,  $B$  is assumed to be skew-symmetrisable, whereas in Theorem 3.26  $B$  is 'only' skew-symmetric. As mentioned earlier, it is possible to view skew-symmetrisable matrices as diagrams, so-called *valued quivers*. On the other hand, a Cartan matrix defines, in a natural way, a so-called *valued graph*, allowing us to identify a Dynkin diagram with the valued graph associated to the corresponding Cartan matrix. With these notions at hand, one can restate Theorem 3.26 in the language of valued quivers (and valued graphs), providing the complete diagram version of Theorem 3.25.

**Example 3.28.** Consider the seed  $\Sigma = (\{x_1, x_2, x_3\}, B)$  with the exchange matrix  $B$ , its Cartan counterpart  $A(B)$  and the quiver  $Q_B$  given below:

$$B = \begin{pmatrix} 0 & 1 & 0 \\ -1 & 0 & -1 \\ 0 & 1 & 0 \end{pmatrix}, \quad A(B) = \begin{pmatrix} 2 & -1 & 0 \\ -1 & 2 & -1 \\ 0 & -1 & 2 \end{pmatrix}, \quad Q_B = 1 \longrightarrow 2 \longleftarrow 3.$$

We observe that the matrix  $A(B)$  and the underlying graph of  $Q_B$  are the Cartan matrix and the Dynkin diagram of type  $A_3$ , respectively.

More generally, if  $\Sigma' = (X', ex', B') \in \text{Mut}(\Sigma)$  is such that  $A(\tilde{B}')$  is a Cartan matrix of finite type (e.g.  $A_n, B_n, \dots$ ) we say that a cluster algebra  $\mathcal{A}(\Sigma)$  (respectively a rooted cluster  $(\mathcal{A}(\Sigma), \Sigma)$ ) has that particular type. As an example, a cluster algebra  $\mathcal{A}(\Sigma)$ , with  $\Sigma$  as in the Example 3.28 above, has type  $A_3$ , whereas a cluster algebra with the initial seed from Example 2.16 has type  $A_2$ .

### 3.2.1 Denominators and root clusters

In this subsection we will discuss some of the basic properties of cluster algebras of finite type, mainly following [32, 17, 18]. We start with a description of the set of cluster variables in terms of the root system associated with a Cartan matrix.

Given a  $n \times n$  Cartan matrix of finite type we denote by  $\Phi$  the corresponding root system, with a simple system  $\Delta = \{\alpha_1, \dots, \alpha_n\}$  and with a set of positive roots  $\Phi_+ \subset \Phi$  with respect to  $\Delta$ . Moreover, we denote by  $\Phi_{\geq -1}$  the union of the simple negative roots  $-\Delta$  and the positive roots  $\Phi_+$  and call the elements of  $\Phi_{\geq -1}$  *almost positive roots*. We will also employ the notation  $x^\alpha = x_1^{d_1} \cdots x_n^{d_n}$  for any vector  $\alpha = d_1\alpha_1 + \cdots + d_n\alpha_n \in \Phi$  in the root lattice.

The following Theorem 3.29 describes the relationship between cluster variables and root systems in detail. For the remainder of this section we will denote by  $\Sigma_\bullet = (X_\bullet, ex_\bullet := \{x_1, \dots, x_n\}, B_\bullet)$  a seed where  $\tilde{B}_\bullet$  is an alternating matrix (cf. §2.1.1) and call it an *alternating seed*.

**Theorem 3.29.** ([17, Theorem 1.9]). *Let  $\Sigma_\bullet = (X_\bullet, ex_\bullet, B_\bullet)$  be an alternating seed such that  $A(\tilde{B}_\bullet)$  is a Cartan matrix of finite type and let  $\Phi$  be the root system associated with  $A(\tilde{B}_\bullet)$ . Then there is a unique bijection  $\alpha \mapsto x[\alpha]$  between  $\Phi_{\geq -1}$  and the cluster variables*

in  $\mathcal{A}(\Sigma_\bullet)$  (respectively, the cluster variables of the rooted cluster algebra  $(\mathcal{A}(\Sigma_\bullet), \Sigma_\bullet)$ ), such that for any  $\alpha \in \Phi_{\geq -1}$ , the cluster variable  $x[\alpha]$  is expressed in terms of the initial cluster  $X_\bullet$  as

$$x[\alpha] = \frac{P_\alpha(X_\bullet)}{x^\alpha}$$

where  $P_\alpha$  is a polynomial in the cluster variables from  $X_\bullet$  with integer coefficients, and non-zero constant term. In particular  $x[-\alpha_i] = x_i \in ex_\bullet$  for  $i = 1, \dots, n$ .

**Remark 3.30.** If we drop the assumption that the initial seed has to be alternating then Theorem 3.29 only holds for cluster algebras with no-coefficients (this was proved, for example, in [14]). However, in the light of the work carried out in Section 5.6.2 in particular but also the previous sections, we wanted to avoid this restriction and hence the additional assumption imposed on the initial seed. Moreover, if we also drop the assumption that the Cartan counterpart of the principal part of the matrix from the initial seed has to be a Cartan matrix, then it becomes easy to produce counterexamples to (the modified version of) Theorem 3.29 above. To see this, consider for example the following initial seed  $\Sigma$ .

$$\Sigma = \left( \{x_1, x_2, x_3\}, \begin{array}{ccc} & x_1 & \longrightarrow & x_2 \\ & \swarrow & & \downarrow \\ & & & x_3 \end{array} \right).$$

Then

$$\mathcal{A}_\Sigma = \left\{ x_1, x_2, x_3, \frac{x_2 + x_3}{x_1}, \frac{x_1 + x_3}{x_2}, \frac{x_1 + x_2}{x_3}, \frac{x_1 + x_2 + x_3}{x_1 x_2}, \frac{x_1 + x_2 + x_3}{x_2 x_3}, \frac{x_1 + x_2 + x_3}{x_1 x_3} \right\}.$$

Now, the root system  $A_3$  can be given as  $\Phi = \Phi_+ \cup \Phi_-$ , where  $\Phi_+ = \{\alpha_1, \alpha_2, \alpha_3, \alpha_1 + \alpha_2, \alpha_2 + \alpha_3, \alpha_1 + \alpha_2 + \alpha_3\}$  and  $\Delta = \{\alpha_1, \alpha_2, \alpha_3\}$  is a simple system. The bijection from Theorem 3.29 is supposed to send the root  $\alpha_1 + \alpha_2 + \alpha_3$  to the cluster variable which has the product  $x_1 x_2 x_3$  in the denominator (when seen as a Laurent polynomial in cluster variables  $x_1, x_2, x_3$  from the initial seed) but such cluster variable does not exist in  $\mathcal{A}(\Sigma)$ .

Let us consider an example.

**Example 3.31.** As mentioned above, the root system of type  $A_3$  can be given as  $\Phi = \Phi_+ \cup \Phi_-$ , where  $\Phi_+ = \{\alpha_1, \alpha_2, \alpha_3, \alpha_1 + \alpha_2, \alpha_2 + \alpha_3, \alpha_1 + \alpha_2 + \alpha_3\}$  and  $\Delta = \{\alpha_1, \alpha_2, \alpha_3\}$  is a

simple system. The Cartan matrix is

$$\begin{pmatrix} 2 & -1 & 0 \\ -1 & 2 & -1 \\ 0 & -1 & 2 \end{pmatrix},$$

so by Theorem 3.29, we can take the seed  $\Sigma$  from Example 3.28. That is,  $\Sigma = (\{x_1, x_2, x_3\}, B)$  with

$$B = \begin{pmatrix} 0 & 1 & 0 \\ -1 & 0 & -1 \\ 0 & 1 & 0 \end{pmatrix}.$$

The correspondence from Theorem 3.29 between  $\Phi_{\geq -1}$  and cluster variables of  $\mathcal{A}(\Sigma)$  is as follows. We have that  $x[-\alpha_i] = x_i$  for  $i = 1, 2, 3$  and that

$$\begin{aligned} x[\alpha_1] &= \frac{x_2 + 1}{x_1}; & x[\alpha_1 + \alpha_2] &= \frac{x_1 x_3 + x_2 + 1}{x_1 x_2}; \\ x[\alpha_2] &= \frac{x_1 x_3 + 1}{x_2}; & x[\alpha_2 + \alpha_3] &= \frac{x_1 x_3 + x_2 + 1}{x_2 x_3}; \\ x[\alpha_3] &= \frac{x_2 + 1}{x_3}; & x[\alpha_1 + \alpha_2 + \alpha_3] &= \frac{x_1 x_3 + (x_2 + 1)^2}{x_1 x_2 x_3}. \end{aligned}$$

Naturally, we would like to know which collections of almost positive roots give rise to clusters. Let us start with the following definition.

**Definition 3.32.** (see [32, Section 5.4]). Let  $\Sigma_{\bullet} = (X_{\bullet}, ex_{\bullet}, B_{\bullet})$  be an alternating seed such that  $A(\tilde{B}_{\bullet})$  is a Cartan matrix of finite type and let  $\Phi$  be the root system associated with  $A(\tilde{B}_{\bullet})$ . A  $B_{\bullet}$ -root cluster  $C$  is the set of roots corresponding to a cluster of  $\mathcal{A}(\Sigma_{\bullet})$  under the bijection from Theorem 3.29.

Let  $A$  be a Cartan matrix and let  $\Phi$  be the corresponding root system with a simple system  $\Delta = \{\alpha_1, \dots, \alpha_n\}$  and set  $[\alpha : \alpha_i]$  to be the coefficient of  $\alpha_i$  in the expansion of a root  $\alpha$  in terms of the simple roots. Now, if  $\beta \in \Phi$  and  $\alpha_i \in \Delta$  then  $s_{\alpha_i}(\beta) \in \Phi$  for all  $1 \leq i \leq n$ . However the set  $\Phi_{\geq -1}$  is not, in general, closed under reflections in hyperplanes orthogonal to simple roots. For example, if we consider the root system  $\Phi$  of type  $A_3$ , as given in Example 3.31, then  $\Phi_{\geq -1} = \{\pm\alpha_1, \pm\alpha_2, \pm\alpha_3, \alpha_1 + \alpha_2, \alpha_2 + \alpha_3, \alpha_1 + \alpha_2 + \alpha_3\}$  and,

for instance,  $s_{\alpha_1}(-\alpha_2) = -\alpha_1 - \alpha_2 \notin \Phi_{\geq -1}$ . We fix this as follows. For  $1 \leq i \leq n$ , we define a piecewise linear function  $\sigma_i : \Phi_{\geq -1} \rightarrow \Phi_{\geq -1}$  (see [18, §2] for more details) by setting

$$\sigma_i(\alpha) = \begin{cases} s_i(\alpha), & \text{if } s_i(\alpha) \in \Phi_{\geq -1}; \\ \alpha, & \text{else.} \end{cases}$$

Now, if  $B \in M_I(\mathbb{Z})$  is a skew-symmetrisable alternating matrix (cf. §2.1.1) and such that  $A(B)$  is a Cartan matrix of finite type then according to [18, §3.1] there exists a unique function  $(-||-)_B : \Phi_{\geq -1} \times \Phi_{\geq -1} \rightarrow \mathbb{N} \cup \{0\}$ , called *compatibility degree*, such that

$$(-\alpha_i || \alpha)_B = \max([\alpha : \alpha_i], 0)$$

for any  $i \in I$  and  $\alpha \in \Phi_{\geq -1}$  and

$$(\alpha || \beta)_B = (\sigma_+(\alpha) || \sigma_+(\beta))_B$$

and

$$(\alpha || \beta)_B = (\sigma_-(\alpha) || \sigma_-(\beta))_B$$

for all  $\alpha, \beta \in \Phi_{\geq -1}$ , where

$$\sigma_+ = \prod_{i \in I_+} \sigma_i \quad \text{and} \quad \sigma_- = \prod_{i \in I_-} \sigma_i. \quad (4)$$

A subset  $\mathcal{C}$  of  $\Phi_{\geq -1}$  satisfying  $(\alpha || \beta)_B = 0$  for all  $\alpha, \beta \in \mathcal{C}$  is said to be *B-compatible*. Finally, we have:

**Theorem 3.33.** ([17], §3). *Let  $\Sigma_\bullet = (X_\bullet, ex_\bullet, B_\bullet)$  be an alternating seed such that  $A(\tilde{B}_\bullet)$  is a Cartan matrix of finite type and let  $\Phi$  be the root system associated with  $A(\tilde{B}_\bullet)$ . Then the  $B_\bullet$ -root clusters are exactly the maximal  $\tilde{B}_\bullet$ -compatible subsets of  $\Phi_{\geq -1}$ .*

We end this introductory chapter with an example.

**Example 3.34.** Let

$$\Sigma = \left( \left\{ \{x_1, x_2\}, \{x_1, x_2\} \right\}, B = \begin{pmatrix} 0 & 1 \\ -1 & 0 \end{pmatrix} \right)$$

be a seed. The cluster algebra associated to  $\Sigma$  is

$$\mathcal{A}(\Sigma) = \mathbb{Z}[x_1, x_2, \frac{x_1 + 1}{x_2}, \frac{x_2 + 1}{x_1}, \frac{x_1 + x_2 + 1}{x_1 x_2}].$$

We have that  $\Sigma$  is an alternating seed and that  $B = \tilde{B}$ . The Cartan counterpart is

$$A(B) = \begin{pmatrix} 2 & -1 \\ -1 & 2 \end{pmatrix},$$

which is the Cartan matrix of type  $A_2$ . The root system of type  $A_2$  is  $\{\pm\alpha_1, \pm\alpha_2, \pm(\alpha_1 + \alpha_2)\}$  and so

$$\Phi_{\geq -1} = \{\pm\alpha_1, \pm\alpha_2, \alpha_1 + \alpha_2\}.$$

We have in this case that  $I = \{1, 2\}$  and that  $I_+ = \{1\}$  and  $I_- = \{2\}$  and so  $\sigma_+ = \sigma_1$  and  $\sigma_- = \sigma_2$ . Immediately, we have that  $(-\alpha_1 || -\alpha_2)_B = (-\alpha_2 || \alpha_1)_B = (-\alpha_1 || \alpha_2)_B = 0$ . Moreover,

$$(\alpha_1 || \alpha_1 + \alpha_2)_B = (\sigma_+(\alpha_1) || \sigma_+(\alpha_1 + \alpha_2))_B = (-\alpha_1 || \alpha_2)_B = 0$$

and similarly

$$(\alpha_2 || \alpha_1 + \alpha_2)_B = (\sigma_-(\alpha_2) || \sigma_-(\alpha_1 + \alpha_2))_B = (-\alpha_2 || \alpha_1)_B = 0.$$

For any other pair  $\alpha, \beta \in \Phi_{\geq -1}$  we have that  $(\alpha || \beta) = 1$  and so the set of all  $B$ -compatible subsets of  $\Phi_{\geq -1}$  is

$$\{\{-\alpha_1, -\alpha_2\}, \{-\alpha_1, \alpha_2\}, \{-\alpha_2, \alpha_1\}, \{\alpha_1, \alpha_1 + \alpha_2\}, \{\alpha_2, \alpha_1 + \alpha_2\}\}.$$

On the other hand, the set of all clusters in  $\mathcal{A}(\Sigma)$  is

$$\left\{ \left\{ \left\{ x_1, x_2 \right\}, \left\{ x_1, \frac{x_1 + 1}{x_2} \right\}, \left\{ x_2, \frac{x_2 + 1}{x_1} \right\}, \left\{ \frac{x_2 + 1}{x_1}, \frac{x_1 + x_2 + 1}{x_1 x_2} \right\}, \left\{ \frac{x_1 + 1}{x_2}, \frac{x_1 + x_2 + 1}{x_1 x_2} \right\} \right\} \right\}.$$

Now, the bijection from Theorem 3.29 sends  $x_i$  to  $-\alpha_i$  for  $i = 1, 2$ ,  $\frac{x_2+1}{x_1}$  to  $\alpha_1$ ,  $\frac{x_1+1}{x_2}$  to  $\alpha_2$  and  $\frac{x_1+x_2+1}{x_1 x_2}$  to  $\alpha_1 + \alpha_2$ . Thus, we can see that the set of all  $B$ -compatible subsets of  $\Phi_{\geq -1}$  coincides with the set of all  $B$ -root clusters, as predicted by Theorem 3.33.

## 4 Preliminaries on category theory

In order to make this thesis as self-contained as possible, we will include here a very brief introduction to categories, closely following books [30] and [34] by Tom Leinster and Emily Riehl, respectively. Two main chapters of this thesis, namely Chapter 5 and Chapter 6, rely heavily on categorical concepts. In Chapter 5 we construct a new category of rooted cluster algebras. Moreover, the notion of a categorical limit, inverse limit in particular, will be the key component in constructing a special family of algebras, called pro-cluster algebras, later in Chapter 6. We highlight the fact that the exposition of the categorical notions we provide here is minimal in the sense that we only include the definitions and examples that are most relevant to our work and best suit our needs. There is, of course, much more to say about the (categorical) concepts we present here, let alone category theory as a whole, and the reader should keep this in mind. A much more comprehensive presentation can be found in the referenced materials.

We also introduce in this chapter a parameter-dependent family of ring homomorphisms between cluster algebras coming from convex polygons (that is, from disks with finitely many marked points and no punctures) and the corresponding inverse systems in the category of rings. For a certain choice of parameters, as we will see later in Chapter 5, we get maps with an interesting geometric interpretation. Moreover, they turn out to be examples of morphisms in our new category of rooted cluster algebras (more on this in Chapter 5) and will be equally important for our discussions in Chapter 6.

### 4.1 Category theory

In Section 4.1.1 we define categories and in 4.1.2 we define functors, discussing, in both cases, some of their basic properties and examples. In Section 4.1.3 we define categorical limits, focusing mainly on inverse limits. Finally, in Section 4.2 we introduce a family of ring homomorphisms between cluster algebras associated with convex polygons and define the corresponding inverse systems in the category of rings.



### 4.1.1 Categories

Broadly speaking, a category consists of objects. We can also travel between objects from a given category: this is done via the notion of morphisms.

**Definition 4.1.** ([30, Definition 1.1.1]). A *category*  $\mathcal{C}$  consists of:

- a collection  $\text{ob}(\mathcal{C})$  of *objects*;
- for each  $A, B \in \text{ob}(\mathcal{C})$ , a collection  $\mathcal{C}(A, B)$  of *maps* or *arrows* or *morphisms* from  $A$  to  $B$ ;
- for each  $A, B, C \in \text{ob}(\mathcal{C})$ , a function

$$\begin{aligned} \mathcal{C}(B, C) \times \mathcal{C}(A, B) &\rightarrow \mathcal{C}(A, C) \\ (g, f) &\mapsto g \circ f, \end{aligned}$$

called *composition*;

- for each  $A \in \text{ob}(\mathcal{C})$ , an element  $1_A$  of  $\mathcal{C}(A, A)$ , called the *identity* on  $A$ ,

satisfying the following axioms:

- *associativity*: for each  $f \in \mathcal{C}(A, B)$ ,  $g \in \mathcal{C}(B, C)$  and  $h \in \mathcal{C}(C, D)$ , we have  $(h \circ g) \circ f = h \circ (g \circ f)$ ;
- *identity laws*: for each  $f \in \mathcal{C}(A, B)$ , we have  $f \circ 1_A = f = 1_B \circ f$ .

**Remark 4.2.** The choice of the most suitable set-theoretical framework for working with categories is not an obvious one. For example, due to the Russel's paradox, we know that the set of all sets does not exist. Based on this, the word "collection" is used in the definition of a category. For a further discussion on the set-theoretical foundations of category theory we refer the reader to [34, Remark 1.1.5] and references therein.

Therefore, to construct a category is to specify the collections of objects and arrows between them, together with the composition rule, which satisfy the axioms from the definition of a category. It is a common practice to name a category after its objects, albeit in some

cases the naming of a category can be more transparent than in others, depending, mostly, on the nature of the objects (or morphisms) at hand, as can be seen in the Table 2 below. We also note that the composition rule, in a given category, is often the most natural one. That is, given the objects of a category, there is often a very natural candidate for the composition. For instance, if the objects are groups and morphisms are group homomorphisms, then the composition rule is simply given by the composition of group homomorphisms. Thus, we will only state the composition rule explicitly if its choice is ambiguous.

Category	Objects	Morphisms
<b>Set</b>	Sets	Functions
<b>Group</b>	Groups	Group homomorphisms
<b>Ring</b>	Rings	Ring homomorphisms
<b>Htpy</b>	Spaces	Homotopy classes of continuous maps
<b>Clus</b> (see [2, Definition 2.6])	Rooted Cluster Algebras	Rooted cluster morphisms (see [2, Definition 2.2])
<b>fClus</b> (Chapter 5, Definition 5.9)	Rooted Cluster Algebras	Freezing rooted cluster morphisms (Chapter 5, Definition 5.2)

Table 2: Examples of categories.

A category  $\mathcal{C}$  is called *small* if it has a set's worth of objects and set's worth of arrows, and *large* otherwise. In each of the categories listed above, the collection of objects is not a set and so all of those categories are large categories.

If a category has no morphisms at all apart from the identities (which, due to the definition of a category, they are committed to have), then we are in the case of a *discrete category*. Thus informally, we can think of a discrete category as a collection of isolated directed loops, indexed by its objects. If the objects of a category  $\mathcal{C}$  are sets (which are often endowed with additional structure) and the morphisms are functions (often structure-preserving, if structure is present), then we call  $\mathcal{C}$  a *concrete category*. Every category, apart from the category **Htpy**, listed in the table above is concrete in this sense.

Let us consider yet another, potentially more enlightening, example of a category that is not a concrete category. Consider a group  $G$ . It defines a category  $\mathbf{BG}$  with a single object. The morphisms of  $\mathbf{BG}$  are represented by the group elements of  $G$ , with composition given by the group operation. The identity morphism for the unique object in  $\mathbf{BG}$  is represented by the identity element of  $G$ . Thus we can see that categories can, and often do, have a much more abstract flavour to them.

Before we move onto discussing functors, we first define when two objects from a category are considered to be the same and discuss a simple way of constructing a new category from an old one.

**Definition 4.3.** ([34, Definition 1.1.9]). A map  $f : A \rightarrow B$  in a category  $\mathcal{C}$  is an *isomorphism* if there exists a map  $g : B \rightarrow A$  in  $\mathcal{C}$  such that  $g \circ f = 1_A$  and  $f \circ g = 1_B$ . We call  $g$  the *inverse* of  $f$  and write  $g = f^{-1}$ . If there exists an isomorphism from  $A$  to  $B$ , we say that  $A$  and  $B$  are *isomorphic* and write  $A \cong B$ .

In Table 3 below we list the isomorphisms in the categories listed in Table 2.

Category	Isomorphisms
<b>Set</b>	bijections
<b>Group</b>	bijjective group homomorphisms
<b>Ring</b>	bijjective ring homomorphisms
<b>Htpy</b>	homotopy equivalences
<b>Clus</b>	bijjective rooted cluster morphisms (see [[2], Corollary 3.10])
<b>fClus</b>	bijjective freezing rooted cluster morphisms (see Corollary 5.19)

Table 3: Isomorphisms in the categories listed in Table 2.

We also note that every morphism in the category  $\mathbf{BG}$  is an isomorphism in the sense of Definition 4.3, since every group element has an inverse.

As we said earlier, to construct a category is to specify its objects, morphisms between

them and its composition law. With that in mind, we construct a new category  $\mathcal{C}^{\text{op}}$  from a category  $\mathcal{C}$ , called the *opposite category* ([30, Construction 1.1.9]), as follows:

- the objects of  $\mathcal{C}^{\text{op}}$  are the objects of  $\mathcal{C}$ ,
- if  $A, B \in \text{ob}(\mathcal{C})$ , then  $\mathcal{C}^{\text{op}}(A, B) = \mathcal{C}(B, A)$ ; if  $f \in \mathcal{C}(B, A)$  then we denote with  $f^{\text{op}} \in \mathcal{C}^{\text{op}}(A, B)$  the corresponding morphisms in  $\mathcal{C}^{\text{op}}$ ,
- $1_A^{\text{op}} := 1_A$  for all  $A \in \text{ob}(\mathcal{C})$ ,
- Let  $f^{\text{op}} \in \mathcal{C}^{\text{op}}(A, B)$  and  $g^{\text{op}} \in \mathcal{C}^{\text{op}}(B, C)$ . Then  $f \in \mathcal{C}(B, A)$  and  $g \in \mathcal{C}(C, B)$  and so we can compose  $g$  with  $f$  in  $\mathcal{C}$  using its composition law. We then define  $g^{\text{op}} \circ f^{\text{op}}$  to be  $(f \circ g)^{\text{op}}$ .

Indeed, with this notion of composition,  $\mathcal{C}^{\text{op}}$  is a category. Informally, we can think of  $\mathcal{C}^{\text{op}}$  as being the same as  $\mathcal{C}$ , since the objects and the morphisms of  $\mathcal{C}^{\text{op}}$  are the same as those of  $\mathcal{C}$ , with a subtlety that to say  $f$  is a morphism from  $B$  to  $A$  in  $\mathcal{C}$  is the same as saying  $f$  is a morphism from  $A$  to  $B$  in  $\mathcal{C}^{\text{op}}$ .

Suppose now  $S$  is a statement in a category  $\mathcal{C}$ . By reversing all the arrows, and the orders of composing them, in  $S$ , we obtain a *dual statement*  $S^{\text{op}}$  in the category  $\mathcal{C}^{\text{op}}$ . The *duality principle* (see [31, §II] for more details) then states that  $S$  is true if and only if  $S^{\text{op}}$  is true. Consider, for example, the following definition.

**Definition 4.4.** ([34, Definition 1.2.7]). Let  $\mathcal{C}$  be a category.

(i) a morphism  $B \xrightarrow{f} C$  in  $\mathcal{C}$  is a *monomorphism* if for all objects  $A$  and maps  $A \begin{array}{c} \xrightarrow{g} \\ \xrightarrow{h} \end{array} B$ ,

$$f \circ g = f \circ h \implies g = h.$$

(ii) a morphism  $A \xrightarrow{f} B$  in  $\mathcal{C}$  is an *epimorphism* if for all objects  $C$  and maps  $B \begin{array}{c} \xrightarrow{g} \\ \xrightarrow{h} \end{array} C$ ,

$$g \circ f = h \circ f \implies g = h.$$

Consider now the statement:  $f$  is a monomorphism in a category  $\mathcal{C}$ . That is,

$$f \circ g = f \circ h \implies g = h.$$

By reversing the arrows and order of the composition in the above statement we get the dual statement:

$$g^{\text{op}} \circ f^{\text{op}} = h^{\text{op}} \circ f^{\text{op}} \implies g^{\text{op}} = h^{\text{op}},$$

in the opposite category  $\mathcal{C}^{\text{op}}$ . But this is the same as saying that  $f^{\text{op}}$  is an epimorphism in  $\mathcal{C}^{\text{op}}$ . Therefore, a morphism  $f$  in  $\mathcal{C}$  is a monomorphism if and only if the morphism  $f^{\text{op}}$  in  $\mathcal{C}^{\text{op}}$  is an epimorphism, by the duality principle. Similarly, a morphism  $f$  in  $\mathcal{C}$  is an epimorphism if and only if the morphism  $f^{\text{op}}$  in  $\mathcal{C}^{\text{op}}$  is a monomorphism. For a more in-depth exposition of the concept of duality we refer the reader to [34, §1.2] and references therein.

### 4.1.2 Functors

Categories can themselves be treated as mathematical objects. Doing so raises a natural question of what morphisms between categories should look like. Intuitively, we would want such morphisms to carry objects to objects and morphisms to morphisms in a way that preserves the structure (determined by the definition of a category) of the corresponding categories. All of these requirements, expressed in a formal language, are met by so-called *functors*.

In this subsection we provide a minimal amount of background information on functors: their definition and some basic examples. For a more thorough exposition we refer the reader to [30, §1.2] or [34, §1.3]. In this thesis, we will not work explicitly with functors, but we will need them to define limits in the next subsection.

**Definition 4.5.** ([30, Definition 1.2.1]). Let  $\mathcal{C}$  and  $\mathcal{D}$  be categories. A *functor*  $F : \mathcal{C} \rightarrow \mathcal{D}$  consists of:

- a function

$$\text{ob}(\mathcal{C}) \rightarrow \text{ob}(\mathcal{D}),$$

written as  $A \mapsto F(A)$ ;

- for each  $A, B \in \text{ob}(\mathcal{C})$ , a function

$$\mathcal{C}(A, B) \rightarrow \mathcal{D}(F(A), F(B)),$$

written as  $f \mapsto F(f)$ ,

satisfying the following axioms:

- $F(g \circ f) = F(g) \circ F(f)$  whenever  $A \xrightarrow{f} B \xrightarrow{g} C$  in  $\mathcal{C}$ ;
- $F(1_A) = 1_{F(A)}$  whenever  $A \in \mathcal{C}$ .

With this notion of a functor we obtain a category **CAT** whose objects are categories and morphisms are functors and with the composition defined in a natural way.

**Example 4.6.** (i) There is a functor from **Group** to **Set** which sends a group to its underlying set and sends a group homomorphism to its underlying function. Thus, we can say that it forgets the group structure of groups and forgets that group homomorphisms are homomorphisms.

(ii) Similarly, there is a functor **Ring**  $\rightarrow$  **Set** forgetting the ring structure on rings and forgetting that ring homomorphisms are homomorphisms.

(iii) Let **Ab** be the category of abelian groups. There is a functor **Ring**  $\rightarrow$  **Ab** that forgets the multiplicative structure, remembering just the underlying additive group and forgets that the ring homomorphisms preserve multiplication.

(iv) There is a functor **Clus**  $\rightarrow$  **Ring** forgetting the fixed initial seed on the rooted cluster algebras and forgetting that rooted cluster morphisms must not only be ring homomorphisms but also satisfy certain additional conditions (see [2, Definition 2.6] for more information).

(v) Let  $G, H$  be groups and let **BG** and **BH** be the corresponding categories with their single objects denoted by  $\bullet$  and  $\diamond$ , respectively. Let  $F$  be a functor from **BG** to **BH**. By definition,  $F$  sends  $\bullet$  to  $\diamond$ . Moreover, it sends a morphism of **BG**, or equivalently, an element of a group  $G$ , to a morphism of **BH**, that is, to an element of a group  $H$ . In other words,  $F$  is a function from  $G$  to  $H$ . In addition, if  $g, g' \in G$ , then  $F(g * g') = F(g) \star F(g')$ , where  $*$ ,  $\star$  denote the composition in **BG** and **BH**, respectively, i.e. the group operations of  $G$  and  $H$ , respectively. Finally, if  $e_G, e_H$  denote the identity

morphisms of  $\mathbf{BG}$  and of  $\mathbf{BH}$ , respectively, then we have that  $F(e_G) = e_H$ . But this means that  $F$  sends the identity element of  $G$  to the identity element of  $H$ . To sum up, it turns out that  $F$  is precisely a group homomorphism from  $G$  to  $H$ .

- (vi) There is a functor from **Set** to **Group** which sends a set to the corresponding free group and sends a map between two sets to the group homomorphism between the corresponding free groups. Such functor is an example of a so-called *free functor*. Free functors can be thought of as dual to forgetful functors.

### 4.1.3 Limits

In this subsection we introduce the abstract notion of a limit and then discuss some particularly useful types of limits, focusing mainly on so-called inverse limits. We will need these limits in particular in Chapter 6.

Limits in a category  $\mathcal{C}$  are defined via so-called diagrams (in  $\mathcal{C}$ ). Given a category  $\mathcal{J}$ , a *diagram of shape  $\mathcal{J}$  in  $\mathcal{C}$*  is a functor  $F : \mathcal{J} \rightarrow \mathcal{C}$ . It helps to think of a diagram simply as a collection of objects and morphisms in a target category  $\mathcal{C}$ , indexed by a fixed category  $\mathcal{J}$ . To emphasize this we will often refer to  $\mathcal{J}$  as an *index category*.

Before we define limits, we first introduce cones.

**Definition 4.7.** ([30, Definition 5.1.18(a)]). Let  $F : \mathcal{J} \rightarrow \mathcal{C}$  be a diagram of shape  $\mathcal{J}$  in a category  $\mathcal{C}$ . A *cone* to  $F$  is an object  $N$  of  $\mathcal{C}$  together with a family  $\psi_A : N \rightarrow F(A)$  of morphisms indexed by the objects  $A$  of  $\mathcal{J}$ , such that for every morphism  $f : A \rightarrow B$  in  $\mathcal{J}$ , we have  $F(f) \circ \psi_A = \psi_B$ .

To simplify notation, we denote a cone to  $F$  by a pair  $(N, (\psi_A)_{A \in \text{ob}(\mathcal{J})})$ , or simply by  $(N, \psi_A)$ , if doing so does not spark confusion.

**Definition 4.8.** ([30, Definition 5.1.18(b)]). A *limit*  $\lim(F)$  of the diagram  $F : \mathcal{J} \rightarrow \mathcal{C}$  is a cone  $(L, \phi)$  to  $F$  such that for every other cone  $(N, \psi)$  to  $F$  there exists a unique morphism

$u : N \rightarrow L$  such that  $\phi_A \circ u = \psi_A$  for all  $A$  in  $\mathcal{J}$ :

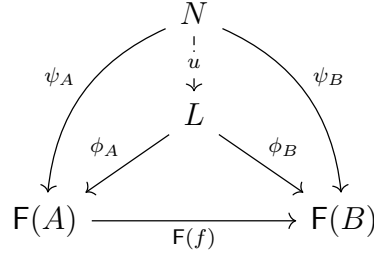

Roughly speaking, the limit has to be "big" enough so that every cone factors through it. On the other hand, it has to be "condensed" enough to only allow for one such factorization. Sometimes, a diagram does not have a limit. If it does, then it is unique up to (unique) isomorphism (see [30, Corollary 6.1.2]) and thus we can speak of *the* limit of a diagram  $F$ .

**Remark 4.9.** The dual notions of limits and cones are *colimits* and *cocones* [30, Definition 5.2.1]. It is straightforward to obtain the formal definitions of those by reversing all morphisms in the above definitions. By [22, Theorem 5.6] every rooted cluster algebra of infinite rank can be written as a colimit (in the category **Clus**) of rooted cluster algebras of finite rank.

A limit  $\lim(F)$  is called *finite* if the index category  $\mathcal{J}$  in the diagram  $F : \mathcal{J} \rightarrow \mathcal{C}$  of shape  $\mathcal{J}$  is finite (that is,  $\mathcal{J}$  is a small category with its sets of objects and morphisms being finite). It is called *small* if the index category  $\mathcal{J}$  in the diagram  $F : \mathcal{J} \rightarrow \mathcal{C}$  of shape  $\mathcal{J}$  is small. A category is called *complete*, respectively *cocomplete*, if it has all small limits, respectively colimits.

**Example 4.10.** A *pullback* (see [30, §5.1] or [34, §3.1] for more details and examples) is a limit of a diagram indexed by a category that consists of three objects and two non-identity morphisms with a common codomain. For example, let  $X, Y, Z$  be commutative rings with identities and  $f : X \rightarrow Z, g : Y \rightarrow Z$  be identity preserving ring homomorphisms. Consider now the subring, denoted by  $X \times_Z Y$ , of the product ring  $X \times Y$  given by

$$X \times_Z Y = \{(x, y) \in X \times Y \mid f(x) = g(y)\}.$$

Then  $X \times_Z Y$  equipped with the projections  $\gamma_X : X \times_Z Y \rightarrow X$  and  $\gamma_Y : X \times_Z Y \rightarrow Y$  is



the pullback of

$$\begin{array}{ccc} & & Y \\ & & \downarrow g \\ X & \xrightarrow{f} & Z \end{array}$$

There are other limits that are gifted with distinctive names. Two important examples are that of a product and of an equalizer as they serve as a kind of litmus test for checking if a category is complete. Now a product is a limit of a diagram indexed by a discrete category with only identity morphisms and an equalizer is a limit of a diagram indexed by (finite) category consisting of two objects and two non-identity morphisms with a common domain. A category is complete if and only if it has all products and small equalizers [30, Proposition 5.1.26]. Dually, a category is cocomplete if and only if it has coequalizers and small coproducts.

**Theorem 4.11.** ([34, §5.6]). *The category **Ring** is both complete and cocomplete.*

Similarly, **Set** and **Group** are examples of complete and cocomplete categories (see [34, §5.6]). On the other hand, by Theorem 5.20, our category **fClus** is neither complete or cocomplete. The same is true for the category **Clus** (see [22, Theorem 4.2]).

Another important example is that of an inverse limit. In order to define inverse limits, we will need the following piece of notation.

**Definition 4.12.** A *preorder* is a reflexive transitive binary relation. A *preordered set*  $(J, \leq)$  is a set  $J$  with a preorder  $\leq$  on it. An *order* on a set is a preorder  $\leq$  with the property that if  $i \leq j$  and  $j \geq i$  then  $i = j$ . We call a preordered set with an order on it a *partially ordered set*.

Broadly speaking, an inverse limit is a limit, in a sense of Definition 4.8, of a diagram coming from a category modelled on a partially ordered set. The diagram is often referred to as inverse system in this setting. More formally, any given partially ordered set  $(J, \leq)$  can be regarded as a category where the objects are elements of  $J$  and where the morphisms consist of arrows  $i \rightarrow j$ , denoted by  $\xrightarrow{ij}$ , if and only if  $i \leq j$ . We denote the category constructed in such way by  $\omega_J$  and let  $J$  be a functor from  $\omega_J^{\text{op}}$  to a category  $\mathcal{C}$ . Note that  $J$  is a functor

from the opposite category  $\omega_J^{\text{op}}$ ; the objects of  $\omega_J^{\text{op}}$  are the elements of  $J$  and the morphisms consist of arrows  $j \rightarrow i$ , denoted by  $\xrightarrow{j^i}$ , if and only if  $i \leq j$ .

**Definition 4.13.** ([34, Definition 3.1.21]). Let  $(J, \leq)$  be a partially ordered set and  $\mathcal{C}$  a category. An *inverse system over  $J$  in  $\mathcal{C}$*  is a diagram of shape  $J$  in  $\mathcal{C}$ . We call the limit of an inverse system over  $J$  an *inverse limit* and denote it by  $\varprojlim J(i)$ .

Let us look at some examples.

**Example 4.14.** Let  $J = (\mathbb{N}, \leq)$ . Then we have that

$$\omega_J^{\text{op}} = \dots \xrightarrow{43} 3 \xrightarrow{32} 2 \xrightarrow{21} 1,$$

together with composites and identities, which are not shown. Suppose now that we have a set  $X_1$  and a chain of subsets

$$\dots \subseteq X_3 \subseteq X_2 \subseteq X_1.$$

Then a functor

$$J : \begin{cases} \omega_J^{\text{op}} & \rightarrow \mathbf{Set} \\ i & \mapsto X_i \\ \xrightarrow{j^i} & \mapsto \iota_{ji}, \end{cases}$$

where  $\iota_{ji}$  denotes the inclusion map  $X_j$  in  $X_i$ , induces an inverse system over  $J$  in  $\mathbf{Set}$  and its limit is  $\bigcap_{i \in \mathbb{N}} X_i$ .

In order to simplify notation, given a partially ordered set  $(J, \leq)$ , we denote an inverse system over  $J$  in a category  $\mathcal{C}$  by a pair  $((C_i)_{i \in J}, (g_{ji})_{i \leq j \in J})$ , or simply by  $(C_i, g_{ji})$ , if clear from the context, where  $C_i = J(i)$  for all  $i \in J$  (or, to be more precise, for all  $i \in \text{ob}(\omega_J^{\text{op}})$ ), and where  $J(\xrightarrow{j^i}) = g_{ji}$  for all  $i \leq j \in J$ .

**Example 4.15.** For a prime number  $p$ , the  *$p$ -adic integers* are defined to be the inverse limit of the inverse system  $(\mathbb{Z}/p^i, q_{ji})$  over  $\mathbb{N}$  of rings and the canonical quotient maps.

**Remark 4.16.** Let  $(J, \leq)$  be a partially ordered set,  $\mathcal{C}$  a category and  $J : \omega_J \rightarrow \mathcal{C}$  a functor. A colimit of a diagram of shape  $J$  is called a *direct limit* [34, Definition 3.1.23].

Since every partially ordered set gives rise to a small category and since the category **Ring** of rings is complete (see Theorem 4.11), it follows that every inverse system in **Ring** has its unique inverse limit. In order to gain a better understanding of what it may look like, consider the following.

**Lemma 4.17.** ([30, p.120-121]). *Let  $(J, \leq)$  be a partially ordered set,  $R_i$  a ring and  $g_{ji} : R_j \rightarrow R_i$  a ring homomorphism, for  $i \leq j \in J$ . For any inverse system  $((R_i)_{i \in J}, (g_{ji})_{i \leq j \in J})$  the subring*

$$R = \left\{ r = (r_i)_{i \in J} \in \prod_{i \in J} R_i \mid r_i = g_{ji}(r_j) \ \forall i \leq j \in J \right\}, \quad (5)$$

*of the direct product of the  $R_i$ 's equipped with natural projections  $\pi_i : R \rightarrow R_i$  gives us the desired inverse limit.*

Assume that a given inverse system is indexed by  $\mathbb{N}$ , for simplicity. An element of  $R$  is a sequence of elements  $r_1, r_2, r_3, \dots, r_i, \dots$  (see Lemma 4.17 above and in particular equation (5) for details regarding the construction of  $R$ ) such that for all  $i \in \mathbb{N}$ ,  $r_i \in R$  and such that  $g_{i+1i}(r_{i+1}) = r_i$  for all  $i \geq 1$ . Things simplify if the maps  $g_{ji}$ , often called the *bonding maps*, are surjective. Then given an arbitrary element  $r_i \in R_i$ , for some  $i \in \mathbb{N}$ , we can always construct an element of  $R$  that has  $r_i$  as its  $i$ th coordinate. For  $1 \leq k < i$ , we have that  $r_k = g_{ik}(r_i)$  and for  $i+1, i+2, \dots$  we choose  $r_{i+1}, r_{i+2}, \dots$  recursively, using the surjectivity of the maps.

The inverse limit constructed in the way described above, that is as a subring of the direct product, is often referred to as *the canonical inverse limit*. The same construction may be used if the  $R_i$ 's are sets, groups or topological spaces (see [[30, p.120-121] for more information), etc. and the homomorphisms are morphisms in the corresponding category.

**Remark 4.18.** Note that if there exists an inverse system in **Ring** built of cluster algebras, which are themselves (commutative) rings, and so-called *freezing rooted cluster morphisms* (Definition 5.2), which are themselves ring homomorphisms, between them, then it is guaranteed to have an inverse limit in **Ring** (see Lemma 4.17 above). On the other hand, the inverse limit of an inverse system in the category **fClus** (Definition 5.9) does not necessarily exist. Now, let  $((\mathcal{A}(\Sigma_i), \Sigma_i), f_{ij})$  be an inverse system (define over  $\mathbb{N}$ , for notational simplicity) in **fClus** and assume that the inverse limit, denoted by  $((\mathcal{A}(\Sigma), \Sigma), f_i)$  of

$((\mathcal{A}(\Sigma_i), \Sigma_i), f_{ij})$  exists in **fClus**. Then  $(\mathcal{A}(\Sigma), f_i)$  is the inverse limit of  $(\mathcal{A}(\Sigma_i), f_{ij})$  in **Ring**. We have that  $(\mathcal{A}(\Sigma), f_i)$  is a cone of  $(\mathcal{A}(\Sigma_i), f_{ij})$  in **Ring** since  $((\mathcal{A}(\Sigma), \Sigma), f_i)$  is a cone of  $((\mathcal{A}(\Sigma_i), \Sigma_i), f_{ij})$  in **fClus**. Now, the unique ring isomorphism from  $\mathcal{A}(\Sigma)$  to the canonical inverse limit  $R$  of  $(\mathcal{A}(\Sigma_i), f_{ij})$  in **Ring** is defined by sending an element  $r \in \mathcal{A}(\Sigma)$  to the element  $(f_1(r), f_2(r), f_3(r), \dots) \in R$ .

## 4.2 Inverse systems of cluster algebras of finite type $A$

In this section we introduce a family of ring homomorphisms each parametrized by a pair of integers, between cluster algebras associated with convex polygons and the corresponding inverse systems in the category of rings.

Let us first set the scene for the remaining part of this chapter. Fix  $m \in \mathbb{Z}_{\geq 3} := \{k \in \mathbb{Z} \mid k \geq 3\}$ . We start with the following definition.

**Definition 4.19.** A *linear order* on a set  $J$  is a binary relation  $<$  with the following properties:

- trichotomy:  $x < y$  or  $y < x$  or  $x = y$ ;
- transitivity: if  $x < y < z$ , then  $x < z$ .

A *linearly ordered set*  $(J, <)$  is a set  $J$  with a linear order  $<$  on  $J$ .

**Definition 4.20.** Let  $(J, <)$  be a linearly ordered set. We call a pair  $(x, y)$  of elements of  $(J, <)$  such that  $x < y$  an *arc* of  $(J, <)$ . We say that two arcs  $(x, y)$  and  $(k, l)$  of  $(J, <)$  *cross*, if  $x < k < y < l$  or if  $k < x < l < y$ .

An arc  $(x, y)$  of  $(J, <)$  is an *edge* if  $\{z \in J \mid x < z < y\} = \emptyset$  or if  $\{z \in J \mid x < z < y\} = J \setminus \{x, y\}$ , otherwise it is a *diagonal*. Moreover, if  $(J, <)$  is such that  $|J| = m$  then we denote by  $m^-$  the smallest element of  $(J, <)$ . That is,  $m^- < x$  for every  $x \in J \setminus \{m^-\}$ . Analogously, we denote by  $m^+$  the largest element of  $(J, <)$ , i.e.  $x < m^+$  for every  $x \in J \setminus \{m^+\}$ .

Recall now that a triangulation of a Riemann surface  $(S, M)$  is a maximal collection of boundary and internal arcs which are pairwise distinct and compatible (cf. Definition 2.6). Similarly, for a linearly ordered set  $(J, <)$ , we have the following definition.

**Definition 4.21.** Let  $(J, <)$  be a linearly ordered set. A *triangulation* of  $(J, <)$  is a maximal set of pairwise non-crossing arcs.

The above definitions will be of particular relevance to the considerations in Chapter 6.

Now, let  $(J, <)$  be such that  $|J| = m$ . We denote by  $\mathcal{P}_m$  a closed disk  $\mathcal{D}$  with  $m$  marked points on its boundary (and no punctures) that are labelled cyclically from  $m^- \in (J, <)$  to  $m^+ \in (J, <)$ . We denote by  $\mathcal{T}_m$  a triangulation of  $\mathcal{P}_m$ , by  $\Sigma_{\mathcal{T}_m}$  the seed associated with  $\mathcal{T}_m$  and by  $\mathcal{A}(\Sigma_{\mathcal{T}_m})$  its corresponding cluster algebra (see Section 2.1.2 for details on constructing seeds from triangulations of marked surfaces and the last paragraph of Section 2.1.3 for geometric interpretation of mutations in a cluster algebra that comes from, in the sense of Section 2.1.2, a marked surface). We note here that there is a natural one-to-one correspondence between triangulations of  $(J, <)$  and  $\mathcal{P}_m$  with the above setting and we will sometimes refer to this correspondence for simplicity. Cluster variables in  $\mathcal{A}(\Sigma_{\mathcal{T}_m})$  are identified with the arcs joining two marked points in  $\mathcal{P}_m$  and for any arc  $(i, j)$  of  $(J, <)$ , we denote by  $x_{ij}$  the variables corresponding to the arc joining a marked point labelled with  $i$  to a marked point labelled with  $j$ . The exchangeable variables are thus the variables corresponding to internal arcs. Under this correspondence, the exchange relations given by mutations in  $\mathcal{A}(\Sigma_{\mathcal{T}_m})$  are the so-called *Plücker* (or *Ptolemy*) *relations* (see [32, §9] for a condensed introduction to Grassmannians and *Plücker relations*):

$$x_{ij}x_{kl} = x_{ik}x_{jl} + x_{il}x_{kj} \text{ for } m^- \leq i < k < j < l \leq m^+, \quad (6)$$

and due to [16, §1] the cluster algebra  $\mathcal{A}(\Sigma_{\mathcal{T}_m})$  is the polynomial ring in the variables  $x_{ij}$  factored by those. That is,

$$\mathcal{A}(\Sigma_{\mathcal{T}_m}) = \frac{\mathbb{Z}[x_{ij} | m^- \leq i < j \leq m^+]}{(x_{ik}x_{jl} = x_{ij}x_{kl} + x_{jk}x_{il} \text{ for } m^- \leq i < j < k < l \leq m^+)}.$$

In the remaining part of this chapter,  $J$  is the set  $[1, m]$  of consecutive integers from 1 to  $m$  and  $<$  is the usual *less than or equal to* binary relation imposed on  $J$ . In this setting,  $m^- = 1$  and  $m^+ = m$  and for  $m \geq 4$ , the cluster algebra  $\mathcal{A}(\Sigma_{\mathcal{T}_m})$  is the homogeneous coordinate ring of the Grassmannian  $G(2, m)$ . That is,

$$\mathcal{A}(\Sigma_{\mathcal{T}_m}) = \frac{\mathbb{Z}[x_{ij} | 1 \leq i < j \leq m]}{(x_{ik}x_{jl} = x_{ij}x_{kl} + x_{jk}x_{il} \text{ for } 1 \leq i < j < k < l \leq m)}.$$

For  $m = 3$ , the cluster algebra  $\mathcal{A}(\Sigma_{\mathcal{T}_3}) = \mathbb{Z}[x_{12}, x_{23}, x_{13}]$  is the polynomial ring in frozen variables corresponding to the boundary arcs of  $\mathcal{P}_3$ .

To establish a valid inverse system, we now pair up a family  $(\mathcal{A}(\Sigma_{\mathcal{T}_m}))_{m \geq 3}$  of cluster algebras with a family of morphisms between them.

Fix  $p, q \in \mathbb{Z}$ .

**Definition 4.22.** For any  $m > 3$  we define a map  $f_{m,m-1}^{p,q} : \mathcal{A}(\Sigma_{\mathcal{T}_m}) \rightarrow \mathcal{A}(\Sigma_{\mathcal{T}_{m-1}})$  by the algebraic extension of the map which sends

$$x_{ij} \mapsto \begin{cases} x_{ij}, & j < m \\ qx_{1m-1}, & i = 1, j = m \\ px_{1m-1}, & i = m-1, j = m \\ px_{1i} + qx_{im-1}, & 1 < i < m-1 < j = m. \end{cases}$$

**Remark 4.23.** Chronologically speaking, only the cases  $p = 0, q = 1$  and  $p = 1, q = 0$  were initially considered. The parameter-dependent version, for general  $p$  and  $q$ , came to life at later stage. The maps  $f_{m,m-1}^{0,1}$  and  $f_{m,m-1}^{1,0}$  were motivated by the geometry of triangulations and were constructed in an attempt of defining an algebraic counterpart of the geometric process called *collapsing a triangle*. In Remark 5.42 we give a detailed explanation of what it means to collapse a triangle in a triangulation of a convex polygon and why we say that the maps  $f_{m,m-1}^{0,1}$  and  $f_{m,m-1}^{1,0}$  correspond to *collapsing a triangle*.

**Proposition 4.24.** *The map  $f_{m,m-1}^{p,q} : \mathcal{A}(\Sigma_{\mathcal{T}_m}) \rightarrow \mathcal{A}(\Sigma_{\mathcal{T}_{m-1}})$  is a well-defined ring homomorphism.*

*Proof.* That  $f_{m,m-1}^{p,q}$  is a ring homomorphism follows directly from the definition. To see that it is well-defined, we consider the following. Let  $x = x_{ij}x_{kl} - x_{il}x_{kj} - x_{ik}x_{jl} \in \mathcal{A}(\Sigma_{\mathcal{T}_m})$  for

some  $1 \leq i < k < j < l \leq m$ . If  $l < m$ , then

$$\begin{aligned} f_{m,m-1}^{p,q}(x) &= x_{ij}x_{kl} - x_{il}x_{kj} - x_{ik}x_{jl} \\ &= 0. \end{aligned}$$

Else, if  $l = m, j < m - 1$  and  $i = 1$ , then

$$\begin{aligned} f_{m,m-1}^{p,q}(x) &= x_{1j}(px_{1k} + qx_{km-1}) - qx_{1m-1}x_{kj} - x_{1k}(px_{1j} + qx_{jm-1}) \\ &= p(x_{1j}x_{1k} - x_{1k}x_{1j}) + q(x_{1j}x_{km-1} - x_{1m-1}x_{kj} - x_{1k}x_{jm-1}) \\ &= p0 + q0 \\ &= 0. \end{aligned}$$

Now, if  $l = m, j < m - 1$  and  $i > 1$ , then

$$\begin{aligned} f_{m,m-1}^{p,q}(x) &= x_{ij}(px_{1k} + qx_{km-1}) - (px_{1i} + qx_{im-1})x_{kj} - x_{ik}(px_{1j} + qx_{jm-1}) \\ &= p(x_{ij}x_{1k} - x_{1i}x_{kj} - x_{ik}x_{1j}) + q(x_{ij}x_{km-1} - x_{im-1}x_{kj} - x_{ik}x_{jm-1}) \\ &= p0 + q0 \\ &= 0. \end{aligned}$$

If  $l = m, j = m - 1$  and  $i = 1$ , then

$$\begin{aligned} f_{m,m-1}^{p,q}(x) &= x_{1m-1}(px_{1k} + qx_{km-1}) - qx_{1m-1}x_{km-1} - x_{1k}px_{1m-1} \\ &= p(x_{1m-1}x_{1k} - x_{1k}x_{1m-1}) + q(x_{1m-1}x_{km-1} - x_{1m-1}x_{km-1}) \\ &= p0 + q0 \\ &= 0, \end{aligned}$$

and finally, if  $l = m, j = m - 1$  and  $i > 1$ , then

$$\begin{aligned} f_{m,m-1}^{p,q}(x) &= x_{im-1}(px_{1k} + qx_{km-1}) - (px_{1i} + qx_{im-1})x_{km-1} - x_{ik}px_{1m-1} \\ &= p(x_{im-1}x_{1k} - x_{1i}x_{km-1} - x_{ik}x_{1m-1}) + q(x_{im-1}x_{km-1} - x_{im-1}x_{km-1}) \\ &= p0 + q0 \\ &= 0. \end{aligned}$$

It follows that  $f_{m,m-1}^{p,q}$  is well-defined and so  $f_{m,m-1}^{p,q}$  is a ring homomorphism.  $\square$

Then immediately, we get the following.

**Corollary 4.25.** *Let  $p, q \in \mathbb{Z}$ . A pair  $((\mathcal{A}(\Sigma_{\mathcal{T}_m}))_{m \geq 3}, (f_{m,n}^{p,q})_{3 \leq n \leq m})$  is an inverse system over  $\mathbb{Z}_{\geq 3}$  in the category of rings.*

Because every cluster algebra in the family  $(\mathcal{A}(\Sigma_{\mathcal{T}_m}))_{m \geq 3}$  is of finite type  $A$ , we refer to a  $p, q$ -dependent family of inverse systems  $(\mathcal{A}(\Sigma_{\mathcal{T}_m}), f_{m,n}^{p,q})$  as a *family of finite type  $A$  inverse systems*. In Chapter 5 we fix some particular choices of triangulations  $\mathcal{T}_m$  and then show that both  $((\mathcal{A}(\Sigma_{\mathcal{T}_m}), \Sigma_{\mathcal{T}_m}), f_{m,n}^{0,1})$  and  $((\mathcal{A}(\Sigma_{\mathcal{T}_m}), \Sigma_{\mathcal{T}_m}), f_{m,n}^{1,0})$  are inverse systems in our new category of rooted cluster algebras.

In Chapter 6, we abstractly define a new family of algebras (with the cluster combinatorics), which are certain subrings of inverse limits of inverse systems of cluster algebras. In certain cases, we are then able to explicitly compute those subrings and show that in fact they are proper subrings of the inverse limits.



## 5 Freezing rooted cluster morphisms and the category of rooted cluster algebras.

It is a natural requirement for a structure preserving map between cluster algebras to not only preserve their algebraic structure but to also commute with mutations. Rooting our cluster algebras enables us to give a precise definition of what it means for ring homomorphisms between not necessarily isomorphic cluster algebras, to commute with mutations. In this chapter we will define a new category **fClus** of rooted cluster algebras. Our category consists of the same objects as the category **Clus** (see [2, Definition 2.6]) that was first introduced by Assem, Dupont and Schiffler in [2], but different morphisms, called *freezing rooted cluster morphisms*. After the formal introduction, we discuss some important properties of our new category and study its morphisms in greater detail.

### 5.1 Freezing rooted cluster morphisms

Given a ring homomorphism between rooted cluster algebras we will have to specify which (sequences of) mutations we require our map to commute with. For that we will need the following definition.

**Definition 5.1.** ([2, Definition 2.1]). Let  $\Sigma$  and  $\Sigma'$  be seeds and let  $f : \mathcal{A}(\Sigma) \rightarrow \mathcal{A}(\Sigma')$  be a map between their associated cluster algebras. A  $\Sigma$ -admissible sequence  $(x_1, \dots, x_l)$  whose image  $(f(x_1), \dots, f(x_l))$  is  $\Sigma'$ -admissible is called  $(f, \Sigma, \Sigma')$ -*biadmissible*.

We are now ready to define freezing rooted cluster morphisms. These will be the morphisms in our category. We fix seeds  $\Sigma = (X, ex, B)$  and  $\Sigma' = (X', ex', B')$ .

**Definition 5.2.** A *freezing rooted cluster morphism (frcm)* is a ring homomorphism  $f : \mathcal{A}(\Sigma) \rightarrow \mathcal{A}(\Sigma')$  such that:

$$(FCM1) \quad f(X) \subseteq X' \cup \mathbb{Z};$$

$$(FCM2) \quad f(X \setminus ex) \subseteq X' \setminus ex' \cup \mathbb{Z};$$

(FCM3) If  $y \in X$  such that  $f(y) \in X'$  and  $(x_1, \dots, x_l)$  is a  $(f, \Sigma, \Sigma')$ -biadmissible sequence, then

$$f(\mu_{x_l} \circ \dots \circ \mu_{x_1}(y)) = \mu_{f(x_l)} \circ \dots \circ \mu_{f(x_1)}(f(y)).$$

**Remark 5.3.** A freezing rooted cluster morphism may send an exchangeable variable to a frozen variable (hence the presence of participle adjective *freezing*) but not the opposite, due to (FCM2). For comparison, a *rooted cluster morphism* introduced by Assem, Dupont and Schiffler in [2], allows for frozen variables to be sent to exchangeable variables but not the other way around.

Next we want to show that rooted cluster algebras together with freezing rooted cluster morphisms assemble into a category. We start with showing that the conditions for a map  $f : \mathcal{A}(\Sigma) \rightarrow \mathcal{A}(\Sigma')$  to be a freezing rooted cluster morphism are preserved under mutation of the initial seeds along biadmissible sequences.

**Proposition 5.4.** *Let  $f : \mathcal{A}(\Sigma) \rightarrow \mathcal{A}(\Sigma')$  be a freezing rooted cluster morphism. Then for every  $(f, \Sigma, \Sigma')$ -biadmissible sequence  $(x_1, \dots, x_l)$ , the map  $f$  induces a freezing rooted cluster morphism  $f : \mathcal{A}(\tilde{\Sigma}) \rightarrow \mathcal{A}(\tilde{\Sigma}')$  between the rooted cluster algebras with initial seeds  $\tilde{\Sigma} = \mu_{x_l} \circ \dots \circ \mu_{x_1}(\Sigma)$  and  $\tilde{\Sigma}' = \mu_{f(x_l)} \circ \dots \circ \mu_{f(x_1)}(\Sigma')$ .*

*Proof.* Since  $\Sigma$  and  $\tilde{\Sigma}$ , respectively  $\Sigma'$  and  $\tilde{\Sigma}'$ , are mutation equivalent, it follows that  $\mathcal{A}(\Sigma) = \mathcal{A}(\tilde{\Sigma})$  and  $\mathcal{A}(\Sigma') = \mathcal{A}(\tilde{\Sigma}')$  as rings, so  $f : \mathcal{A}(\tilde{\Sigma}) \rightarrow \mathcal{A}(\tilde{\Sigma}')$  is a well-defined ring homomorphism. Let  $\Sigma = (X, ex, B)$  and  $\Sigma' = (X', ex', B')$  and let  $\tilde{\Sigma} = (\tilde{X}, \tilde{ex}, \tilde{B})$  and  $\tilde{\Sigma}' = (\tilde{X}', \tilde{ex}', \tilde{B}')$ . Let  $\tilde{x} \in \tilde{X}$ . Every such  $\tilde{x}$  is of the form  $\tilde{x} = \mu_{x_l} \circ \dots \circ \mu_{x_1}(x)$  for an  $x \in X$ . If  $f(x) \in \mathbb{Z}$ , then because  $(x_1, \dots, x_l)$  is  $(f, \Sigma, \Sigma')$ -biadmissible we have  $x \neq x_i$ , for all  $1 \leq i \leq l$ . Thus  $\mu_{x_l} \circ \dots \circ \mu_{x_1}(x) = x = \tilde{x}$  and  $f(\tilde{x}) = f(x) \in \mathbb{Z}$ . On the other hand, if  $f(x) \in X'$  then it follows from axiom (FCM3) that

$$f(\tilde{x}) = f(\mu_{x_l} \circ \dots \circ \mu_{x_1}(x)) = \mu_{f(x_l)} \circ \dots \circ \mu_{f(x_1)}(f(x)),$$

which lies in  $\tilde{X}'$  and we deduce that  $f : \mathcal{A}(\tilde{\Sigma}) \rightarrow \mathcal{A}(\tilde{\Sigma}')$  satisfies (FCM1). Next, consider  $\tilde{x} \in \tilde{X} \setminus \tilde{ex} = X \setminus ex$ . Since  $f$  satisfies axiom (FCM2) and since  $\tilde{x} \in X \setminus ex$ , we have that  $f(\tilde{x}) \in X' \setminus ex' \cup \mathbb{Z} = \tilde{X}' \setminus \tilde{ex}' \cup \mathbb{Z}$ . Therefore,  $f : \mathcal{A}(\tilde{\Sigma}) \rightarrow \mathcal{A}(\tilde{\Sigma}')$  satisfies (FCM2).

It is left to show that it also satisfies (FCM3). Now, because  $e\tilde{x} = \mu_{x_l} \circ \cdots \circ \mu_{x_1}(ex)$  and  $e\tilde{x}' = \mu_{f(x_l)} \circ \cdots \circ \mu_{f(x_1)}(ex')$ , every  $(f, \tilde{\Sigma}, \tilde{\Sigma}')$ -biadmissible sequence  $(y_1, \dots, y_m)$  gives rise to a  $(f, \Sigma, \Sigma')$ -biadmissible sequence  $(x_1, \dots, x_l, y_1, \dots, y_m)$ . Let now  $\tilde{y} \in \tilde{X}$  be such that  $f(\tilde{y}) \in \tilde{X}'$ . We have  $\tilde{y} = \mu_{x_l} \circ \cdots \circ \mu_{x_1}(y)$  for a  $y \in X$ . Since  $f : \mathcal{A}(\Sigma) \rightarrow \mathcal{A}(\Sigma')$  satisfies (FCM1), we have  $f(y) \in X' \cup \mathbb{Z}$ . If  $f(y) \in \mathbb{Z}$ , then also  $f(\tilde{y}) \in \mathbb{Z}$ , a contradiction. Thus  $f(y) \in X'$  and by axiom (FCM3) for  $f : \mathcal{A}(\Sigma) \rightarrow \mathcal{A}(\Sigma')$  we have

$$\begin{aligned} f(\mu_{y_m} \circ \cdots \circ \mu_{y_1}(\tilde{y})) &= f(\mu_{y_m} \circ \cdots \circ \mu_{y_1} \circ \mu_{x_l} \circ \cdots \circ \mu_{x_1}(y)) \\ &= \mu_{f(y_m)} \circ \cdots \circ \mu_{f(y_1)} \circ \mu_{f(x_l)} \circ \cdots \circ \mu_{f(x_1)}(f(y)) \\ &= \mu_{f(y_m)} \circ \cdots \circ \mu_{f(y_1)}(f(\tilde{y})). \end{aligned}$$

Thus axiom (FCM3) is satisfied for  $f : \mathcal{A}(\tilde{\Sigma}) \rightarrow \mathcal{A}(\tilde{\Sigma}')$  and we are done.  $\square$

We are now ready to show that freezing rooted cluster morphism are closed under composition.

**Proposition 5.5.** *The composition of freezing rooted cluster morphisms is a freezing rooted cluster morphism.*

*Proof.* We fix three rooted cluster algebras  $\mathcal{A}_1, \mathcal{A}_2$  and  $\mathcal{A}_3$  with respective initial seeds  $\Sigma_1, \Sigma_2$  and  $\Sigma_3$  where  $\Sigma_i = (X_i, ex_i, B_i)$  for  $i = 1, 2, 3$  and consider freezing rooted cluster morphisms  $f : \mathcal{A}_1 \rightarrow \mathcal{A}_2$  and  $g : \mathcal{A}_2 \rightarrow \mathcal{A}_3$ . The composition  $g \circ f$  is a ring homomorphism from  $\mathcal{A}_1$  to  $\mathcal{A}_3$ . We also have that it satisfies (FCM1) as

$$(g \circ f)(X_1) = g(f(X_1)) \subseteq g(X_2 \cup \mathbb{Z}) \subseteq X_3 \cup \mathbb{Z}$$

and that it satisfies (FCM2) as

$$(g \circ f)(X_1 \setminus ex_1) = g(f((X_1 \setminus ex_1))) \subseteq g(X_2 \setminus ex_2 \cup \mathbb{Z}) \subseteq X_3 \setminus ex_3 \cup \mathbb{Z}.$$

It is left to show that it also satisfies (FCM3). Let  $(x_1, \dots, x_l)$  be a  $((g \circ f), \Sigma_1, \Sigma_3)$ -biadmissible sequence. First, we claim that  $(x_1, \dots, x_l)$  is  $(f, \Sigma_1, \Sigma_2)$ -biadmissible. We prove this by induction on the length  $l$  of the sequence. It is trivially satisfied for sequences of length  $l = 0$ . Assume now that it is satisfied for all  $((g \circ f), \Sigma_1, \Sigma_3)$ -biadmissible sequences of length at most  $l \geq 0$  and let  $(x_1, \dots, x_{l+1})$  be  $((g \circ f), \Sigma_1, \Sigma_3)$ -biadmissible sequence of length

$l+1$ . Let  $\tilde{\Sigma}_1 = \mu_{x_l} \circ \cdots \circ \mu_{x_1}(\Sigma_1)$  and  $\tilde{\Sigma}_2 = \mu_{f(x_l)} \circ \cdots \circ \mu_{f(x_1)}(\Sigma_2)$  and let  $\tilde{\Sigma}_1 = (\tilde{X}_1, \tilde{e}x_1, \tilde{B}_1)$  and  $\tilde{\Sigma}_2 = (\tilde{X}_2, \tilde{e}x_2, \tilde{B}_2)$ . By induction hypothesis  $(x_1, \dots, x_l)$  is  $(f, \Sigma_1, \Sigma_2)$ -biadmissible and so  $f : \mathcal{A}(\tilde{\Sigma}_1) \rightarrow \mathcal{A}(\tilde{\Sigma}_2)$  is a freezing rooted cluster morphism, by Proposition 5.4. Now, since  $(x_1, \dots, x_{l+1})$  is  $\Sigma_1$ -admissible, it follows that  $x_{l+1} \in \tilde{e}x_1$  and so since  $f : \mathcal{A}(\tilde{\Sigma}_1) \rightarrow \mathcal{A}(\tilde{\Sigma}_2)$  satisfies (FCM1) we have  $f(x_{l+1}) \in \tilde{X}_2 \cup \mathbb{Z}$ . If  $f(x_{l+1}) \in \mathbb{Z}$ , then  $g(f(x_{l+1})) \in \mathbb{Z}$  and so  $(g \circ f)(x_{l+1})$  is not exchangeable, a contradiction. Next, if  $f(x_{l+1}) \in \tilde{X}_2 \setminus \tilde{e}x_2 = X_2 \setminus ex_2$ , then  $g(f(x_{l+1})) \in X_3 \setminus ex_3 \cup \mathbb{Z}$ , since  $g$  satisfies (FCM2), and so  $(g \circ f)(x_{l+1})$  is not exchangeable, another contradiction. Thus  $f(x_{l+1}) \in \tilde{e}x_2$  and so  $(x_1, \dots, x_{l+1})$  is  $(f, \Sigma_1, \Sigma_2)$ -biadmissible.

From the above, we have that  $(f(x_1), \dots, f(x_{l+1}))$  is  $\Sigma_2$ -admissible and therefore, as  $(g(f(x_1)), \dots, g(f(x_{l+1})))$  is  $\Sigma_3$ -admissible, the sequence  $(f(x_1), \dots, f(x_{l+1}))$  is  $(g, \Sigma_2, \Sigma_3)$ -biadmissible. Now, let  $x \in X_1$  be s.t.  $(g \circ f)(x) \in X_3$ . Since  $f$  satisfies axiom (FCM1),  $f(x) \in X_2 \cup \mathbb{Z}$ . If  $f(x) \in \mathbb{Z}$ , then  $g(f(x)) \in \mathbb{Z}$  and so  $(g \circ f)(x) \notin X_3$ , a contradiction. Thus  $f(x) \in X_2$ . Then we get

$$\begin{aligned}
(g \circ f)(\mu_{x_{l+1}} \circ \cdots \circ \mu_{x_1}(x)) &= g(f(\mu_{x_{l+1}} \circ \cdots \circ \mu_{x_1}(x))) \\
&= g(\mu_{f(x_{l+1})} \circ \cdots \circ \mu_{f(x_1)}(f(x))) \\
&= \mu_{g(f(x_{l+1}))} \circ \cdots \circ \mu_{g(f(x_1))}(g(f(x))) \\
&= \mu_{(g \circ f)(x_{l+1})} \circ \cdots \circ \mu_{(g \circ f)(x_1)}((g \circ f)(x)),
\end{aligned}$$

where the second equality follows from  $(x_1, \dots, x_{l+1})$  being  $(f, \Sigma_1, \Sigma_2)$ -biadmissible and the third equality follows from  $(f(x_1), \dots, f(x_{l+1}))$  being  $(g, \Sigma_2, \Sigma_3)$ -biadmissible. Thus,  $g \circ f : \mathcal{A}_1 \rightarrow \mathcal{A}_3$  is a freezing rooted cluster morphism.  $\square$

## 5.2 Examples of freezing rooted cluster morphisms

In this section we give several examples of freezing rooted cluster morphisms. We may “delete” cluster variables by specializing them to integers. More importantly, we may send exchangeable variables to frozen cluster variables - the process that we will refer to as “freezing”. To show some of those capabilities in action, we first give here a few examples of freezing rooted cluster morphisms between cluster algebras of finite type A. In Section 5.7, we will consider a concrete example of freezing rooted cluster morphism from a cluster algebra of finite type  $D_4$  to a cluster algebra of finite type  $A_3$ , as well as give a recipe for

constructing freezing rooted cluster morphisms between *acyclic* (rooted) cluster algebras, that is cluster algebras that arise from a quiver mutation equivalent to a quiver with no directed cycles between exchangeable vertices.

Throughout the rest of this thesis, we will mark vertices associated to frozen variables with squares, when working with quivers.

**Example 5.6.** Consider the seeds

$$\Sigma = \left( \{x_1, x_2, x_3, x_4\}, \{x_1, x_2\}, x_1 \longrightarrow x_2 \begin{array}{l} \nearrow \boxed{x_3} \\ \searrow \boxed{x_4} \end{array} \right)$$

and

$$\Sigma' = \left( \{z_1, z_2\}, \{z_1\}, z_1 \longrightarrow \boxed{z_2} \right)$$

with associated cluster algebras

$$\mathcal{A}(\Sigma) = \mathbb{Z} \left[ x_1, x_2, x_3, x_4, \frac{x_2 + 1}{x_1}, \frac{x_1 x_4 + x_3}{x_2}, \frac{x_1 x_4 + x_3 + x_2 x_3}{x_1 x_2} \right]$$

and

$$\mathcal{A}(\Sigma') = \mathbb{Z} \left[ z_1, z_2, \frac{z_2 + 1}{z_1} \right].$$

Consider the ring homomorphism  $f : \mathcal{A}(\Sigma) \rightarrow \mathcal{A}(\Sigma')$ , which is defined by sending  $x_i \mapsto z_i$  for  $i = 1, 2$ ,  $x_3 \mapsto z_2$  and  $x_4 \mapsto 0$  and extending those rules algebraically. Then  $f$  satisfies axioms (FCM1) and (FCM2) by construction. To show that  $f$  also satisfies axiom (FCM3) we notice first that the only exchangeable variable in  $\Sigma$  that is mapped to an exchangeable variable in  $\Sigma'$  by  $f$  is  $x_1$ . We have that

$$f(\mu_{x_1}(x_1)) = f\left(\frac{x_2 + 1}{x_1}\right) = \frac{z_2 + 1}{z_1} = \mu_{z_1}(z_1) = \mu_{f(x_1)}(f(x_1)).$$

Now the only exchangeable variable in  $\mu_{x_1}(\Sigma)$  that is sent to an exchangeable variable in  $\mu_{z_1}(\Sigma')$  by  $f$  is  $\frac{x_2+1}{x_1}$  and since the mutation is involutive we have

$$f\left(\mu_{\frac{x_2+1}{x_1}}\left(\frac{x_2 + 1}{x_1}\right)\right) = f(x_1) = z_1 = \mu_{\frac{z_2+1}{z_1}}\left(\frac{z_2 + 1}{z_1}\right).$$

and  $\mu_{\frac{x_2+1}{x_1}} \circ \mu_{x_1}(\Sigma) = \Sigma$  and  $\mu_{\frac{z_2+1}{z_1}} \circ \mu_{z_1}(\Sigma') = \Sigma'$ . It follows that all  $(f, \Sigma, \Sigma')$ -biadmissible sequences have alternating entries  $x_1$  and  $\frac{x_2+1}{x_1}$ . Lastly, we have

$$f(\mu_{x_1}(x_i)) = f(x_i) = \mu_{f(x_1)}(f(x_i))$$

and

$$f(\mu_{\frac{x_2+1}{x_1}}(x_i)) = f(x_i) = \mu_{f(\frac{x_2+1}{x_1})}(f(x_i))$$

for  $i = 2, 3$ . Thus  $f$  commutes with every  $(f, \Sigma, \Sigma')$ -biadmissible sequence and so it is a freezing rooted cluster morphism.

**Example 5.7.** Consider the seeds

$$\Sigma = (\{x_1, x_2\}, \{x_1\}, x_1 \longrightarrow \boxed{x_2}) \text{ and } \Sigma' = (\{z_1\}, \{z_1\}, z_1)$$

with associated cluster algebras

$$\mathcal{A}(\Sigma) = \mathbb{Z}\left[x_1, x_2, \frac{x_2+1}{x_1}\right] \text{ and } \mathcal{A}(\Sigma') = \mathbb{Z}\left[z_1, \frac{2}{z_1}\right].$$

Consider the ring homomorphism  $g : \mathcal{A}(\Sigma) \rightarrow \mathcal{A}(\Sigma')$ , which is defined by sending  $x_1 \mapsto z_1$  and sending  $x_2 \mapsto 1$  and extending algebraically. Then  $g$  satisfies axioms (FCM1) and (FCM2) by definition. Analogously to our argument in Example 5.6 one can show that every  $(g, \Sigma, \Sigma')$ -biadmissible sequence consists of alternating entries  $x_1$  and  $\mu_{x_1}(x_1) = \frac{x_2+1}{x_1}$  only and that  $g$  commutes with every such sequence. Thus axiom (FCM3) is satisfied and  $g$  is a freezing rooted cluster morphism.

**Example 5.8.** Consider the seeds

$$\Sigma = (\{x_1, x_2, x_3, x_4\}, \{x_1, x_2\}, x_1 \longrightarrow x_2 \begin{array}{l} \nearrow \boxed{x_3} \\ \searrow \boxed{x_4} \end{array} )$$

and

$$\Sigma' = (\{z_1\}, \{z_1\}, z_1)$$

with associated cluster algebras

$$\mathcal{A}(\Sigma) = \mathbb{Z} \left[ x_1, x_2, x_3, x_4, \frac{x_2 + 1}{x_1}, \frac{x_1 x_4 + x_3}{x_2}, \frac{x_1 x_4 + x_3 + x_2 x_3}{x_1 x_2} \right]$$

and

$$\mathcal{A}(\Sigma') = \mathbb{Z} \left[ z_1, \frac{2}{z_1} \right].$$

Consider the ring homomorphism  $h : \mathcal{A}(\Sigma) \rightarrow \mathcal{A}(\Sigma')$  that is defined by sending  $x_1 \mapsto z_1$ ,  $x_i \mapsto 1$  for  $i = 2, 3$  and  $x_4 \mapsto 0$ . We notice that  $h = g \circ f$  and so by Proposition 5.5,  $h$  is a freezing rooted cluster morphism.

### 5.3 The category of rooted cluster algebras

By Proposition 5.5, the composition of freezing rooted cluster morphisms is a freezing rooted cluster morphism. An identity ring homomorphism trivially satisfies the axioms (FCM1), (FCM2) and (FCM3) and so is a freezing rooted cluster morphism. The composition of freezing rooted cluster morphisms is associative since the composition of ring homomorphisms is. Therefore, the class of all rooted cluster algebras together with freezing rooted cluster morphisms forms a category.

**Definition 5.9.** (cf. [2, Definition 2.6]). The *category of rooted cluster algebras* is the category **fClus** defined by:

- The objects in **fClus** are rooted cluster algebras;
- The morphisms between two rooted cluster algebras are the freezing rooted cluster morphisms.

One should not undervalue the importance of axiom (FCM2) in the definition of freezing rooted cluster morphisms. In particular, axiom (FCM2) is necessary to ensure that the composition of freezing rooted cluster morphisms is again a freezing rooted cluster morphism, as shown in the example below.

**Example 5.10.** ([22, Example 3.15]). Consider the seeds

$$\Sigma_1 = \left( \{x_1, x_2, x_3\}, \{x_2\}, \begin{pmatrix} 0 & 1 & 0 \\ -1 & 0 & 1 \\ 0 & -1 & 0 \end{pmatrix} \right),$$

$$\Sigma_2 = (\{z\}, \emptyset, [0]),$$

$$\Sigma_3 = \left( \{y_1, y_2\}, \{y_1, y_2\}, \begin{pmatrix} 0 & 1 \\ -1 & 0 \end{pmatrix} \right).$$

The quivers  $Q_1, Q_2, Q_3$  corresponding to (the exchange matrices of) the seeds  $\Sigma_1, \Sigma_2$  and  $\Sigma_3$ , respectively, are given by

$$Q_1 = \boxed{x_1} \longrightarrow x_2 \longrightarrow \boxed{x_3}, \quad Q_2 = \boxed{z}, \quad Q_3 = y_1 \longrightarrow y_2.$$

The cluster algebras associated with the seeds  $\Sigma_1, \Sigma_2$  and  $\Sigma_3$  are

$$\mathcal{A}(\Sigma_1) = \mathbb{Z}[x_1, x_2, x_3, \frac{x_1 + x_3}{x_2}], \quad \mathcal{A}(\Sigma_2) = \mathbb{Z}[z]$$

and

$$\mathcal{A}(\Sigma_3) = \mathbb{Z}[y_1, y_2, \frac{1 + y_2}{y_1}, \frac{1 + y_1}{y_2}, \frac{1 + y_1 + y_2}{y_1 y_2}].$$

Consider the ring homomorphism  $f : \mathcal{A}(\Sigma_1) \rightarrow \mathcal{A}(\Sigma_2)$  which is defined by sending  $x_i \mapsto z$  for all  $i = 1, 2, 3$ , and  $g : \mathcal{A}(\Sigma_2) \rightarrow \mathcal{A}(\Sigma_3)$  defined by sending  $z \mapsto y_1$ . Both  $f : \mathcal{A}(\Sigma_1) \rightarrow \mathcal{A}(\Sigma_2)$  and  $g : \mathcal{A}(\Sigma_2) \rightarrow \mathcal{A}(\Sigma_3)$  satisfy axiom (FCM1), but  $g$  does not satisfy axiom (FCM2). Since there are no  $(f, \Sigma_1, \Sigma_2)$ -biadmissible sequences and no  $(g, \Sigma_2, \Sigma_3)$ -biadmissible sequences we have that  $f$  and  $g$  satisfy axiom (FCM3) trivially. Yet, the composition  $g \circ f$  does not satisfy axiom (FCM3). Let us consider the  $(g \circ f, \Sigma_1, \Sigma_3)$ -biadmissible sequence  $(x_2)$ . We have

$$g \circ f(\mu_{x_2}(x_2)) = g \circ f\left(\frac{x_1 + x_3}{x_2}\right) = g(2) = 2$$

but

$$\mu_{g \circ f(x_2)}(g \circ f(x_2)) = \mu_{y_1}(y_1) = \frac{1 + y_2}{y_1}.$$

## 5.4 Isomorphisms in the category **fClus**.

In this section we characterize isomorphisms in the category **fClus**. In [2] the authors prove that isomorphisms in the category **Clus** (see Definition 5.12 below) coincide with the



bijjective rooted cluster morphisms. We will implement a strategy similar to that used by the authors in [2, §3] to prove that isomorphisms in **fClus** coincide with bijjective freezing rooted cluster morphisms. Throughout this section we refer to the notion of rooted cluster morphisms and the category **Clus** frequently and so we include here their definitions and one particularly useful result (namely, Lemma 5.14), for the reader's convenience.

We fix two seeds  $\Sigma = (X, ex, B)$  and  $\Sigma' = (X', ex', B')$ .

**Definition 5.11.** ([2, Definition 2.2]). A *rooted cluster morphism* is a ring homomorphism  $f : \mathcal{A}(\Sigma) \rightarrow \mathcal{A}(\Sigma')$  such that:

(FCM1)  $f(X) \subseteq X' \cup \mathbb{Z}$ ;

(CM2)  $f(ex) \subseteq ex' \cup \mathbb{Z}$ ;

(FCM3) If  $y \in X$  s.t.  $f(y) \in X'$  and  $(x_1, \dots, x_l)$  is a  $(f, \Sigma, \Sigma')$ -biadmissible sequence, then

$$f(\mu_{x_l} \circ \dots \circ \mu_{x_1}(y)) = \mu_{f(x_l)} \circ \dots \circ \mu_{f(x_1)}(f(y)).$$

**Definition 5.12.** ([2, Definition 2.6]). The *category of rooted cluster algebras* is the category **Clus** defined by:

- The objects in **Clus** are the rooted cluster algebras ;
- The morphisms between two rooted cluster algebras are the rooted cluster morphisms.

**Remark 5.13.** Consider the situation where the objects are all rooted cluster algebras and where we allow the morphisms between them to be either rooted cluster morphisms or freezing rooted cluster morphisms. Such pair does not form a category. As we saw in Example 5.10, the composition of freezing rooted cluster morphism (map  $f$ ) with rooted cluster morphism (map  $g$ ) does not commute with biadmissible mutations, i.e. it does not satisfy the axiom (FCM3).

**Lemma 5.14.** ([2, Corollary 3.2]). *Let  $f : \mathcal{A}(\Sigma) \rightarrow \mathcal{A}(\Sigma')$  be a bijjective ring homomorphism satisfying (FCM1). Then  $f$  induces a bijection from  $X$  to  $X'$ . Moreover, if  $f$  satisfies (CM2), then  $f$  induces a bijection from  $ex$  to  $ex'$ .*

Now we start working towards the main result of this section. We begin with the following corollary.

**Corollary 5.15.** (cf. [2, Lemma 3.1]). *Let  $f : \mathcal{A}(\Sigma) \rightarrow \mathcal{A}(\Sigma')$  be a surjective ring homomorphism satisfying (FCM1). Then  $X' \subset f(X)$  and  $ex' \subset f(ex)$ .*

*Proof.* The statement is the same as the statement of Lemma 3.1 in [2] and so it follows from the proof of [2, Lemma 3.1].  $\square$

**Lemma 5.16.** *Let  $f : \mathcal{A}(\Sigma) \rightarrow \mathcal{A}(\Sigma')$  be a bijective ring homomorphism satisfying (FCM1). Then  $f$  induces a bijection from  $X$  to  $X'$ . Moreover, if  $f$  satisfies (FCM2), then  $f$  induces a bijection from  $ex$  to  $ex'$ .*

*Proof.* That  $f$  induces a bijection from  $X$  to  $X'$  follows directly from Lemma 5.14. Furthermore, if  $f$  satisfies (FCM2), then  $f$  induces an injection from  $X \setminus ex$  to  $X' \setminus ex'$ . We claim that  $X' \setminus ex' \subset f(X \setminus ex)$ . Suppose not, that is, let  $y \in X' \setminus ex'$  and suppose there exists  $x \in ex$  such that  $f(x) = y$ . We have that

$$f(\mu_x(x)) = f\left(\frac{1}{x} \left( \prod_{\substack{z \in X \\ b_{xz} > 0}} z^{b_{xz}} + \prod_{\substack{z \in X \\ b_{xz} < 0}} z^{-b_{xz}} \right)\right) \quad (7)$$

$$= \frac{1}{y} \left( M_1 + M_2 \right), \quad (8)$$

where

$$M_1 = \prod_{\substack{z \in X \\ b_{xz} > 0}} f(z)^{b_{xz}} \quad \text{and} \quad M_2 = \prod_{\substack{z \in X \\ b_{xz} < 0}} f(z)^{-b_{xz}}.$$

But then there must exist at least one  $z \in X$  (if both products in (8) are non-empty there are at least two such distinct variables) such that  $z \neq x$  and such that  $f(z) = y$ . If not, then the partial degree of either  $M_1$  or  $M_2$  with respect to  $y$  is  $-1$  and so  $f(\mu_x(x)) \notin \mathbb{Z}[X' \setminus ex][ex']$ . Due to the Laurent Phenomenon (cf. Section 2.1.5) we have  $f(\mathcal{A}(\Sigma)) \not\subseteq \mathcal{A}(\Sigma')$ , a contradiction. Therefore we must have that  $f(z) = y$ . But this means that  $f$  is not bijective, another contradiction. Therefore  $X' \setminus ex' \subset f(X \setminus ex)$  and so  $f$  induces a bijection from  $X \setminus ex$  to  $X' \setminus ex'$ . It then follows that  $f$  induces a bijection from  $ex$  to  $ex'$ , as required.  $\square$

Next we show that bijective rooted cluster morphisms coincide with bijective freezing rooted cluster morphisms and later that isomorphisms in **Clus** coincide with isomorphisms in **fClus**.

**Proposition 5.17.** *Let  $f : \mathcal{A}(\Sigma) \rightarrow \mathcal{A}(\Sigma')$  be a bijective ring homomorphism. Then  $f$  is a rooted cluster morphism if and only if  $f$  is a freezing rooted cluster morphism.*

*Proof.* Assume first that  $f$  is a rooted cluster morphism. Then by Lemma 5.14 it induces a bijection between  $X \setminus ex$  and  $X' \setminus ex'$  and between  $ex$  and  $ex'$ . Therefore, it satisfies (FCM1) and (FCM2). Similarly, if we assume that  $f$  is a freezing rooted cluster morphism then by Lemma 5.16 it induces a bijection between  $X \setminus ex$  and  $X' \setminus ex'$  and between  $ex$  and  $ex'$  and so it satisfies (FCM1) and (CM2). The result follows.  $\square$

**Lemma 5.18.** *Let  $f : \mathcal{A}(\Sigma) \rightarrow \mathcal{A}(\Sigma')$  be a ring homomorphism. Then  $f$  is an isomorphism in **Clus** if and only if  $f$  is an isomorphism in **fClus**.*

*Proof.* If  $f$  is an isomorphism in **Clus** (respectively, **fClus**), then  $f$  is an invertible rooted cluster morphism (respectively, freezing rooted cluster morphism) and we denote by  $g : \mathcal{A}(\Sigma') \rightarrow \mathcal{A}(\Sigma)$  its inverse in **Clus** (respectively, **fClus**). Then  $g$  is also an isomorphism in **Clus** (respectively, **fClus**) with  $f$  being its inverse. Now because **Clus** (respectively, **fClus**) is a concrete category, it follows that both  $f$  and  $g$  are bijective and so by Proposition 5.17 we have that both  $f$  and  $g$  are freezing rooted cluster morphisms (respectively, rooted cluster morphisms) and so  $f$  is an isomorphism in **fClus** (respectively, in **Clus**).  $\square$

Finally, we can deduce the following.

**Corollary 5.19.** *The isomorphisms in **fClus** coincide with the bijective freezing rooted cluster morphisms.*

*Proof.* If  $f : \mathcal{A}(\Sigma) \rightarrow \mathcal{A}(\Sigma')$  is an isomorphism in **fClus** then by Lemma 5.18 it is an isomorphism in **Clus**. Then by [2, Corollary 3.10] it is a bijective rooted cluster morphism. It then follows from Proposition 5.17 that it is a bijective freezing rooted cluster morphism.

Conversely, if  $f$  is a bijective freezing rooted cluster morphism, then it is a bijective rooted cluster morphism by Proposition 5.17 and so an isomorphism in **Clus**, by [2, Corollary 3.10]. Then from Lemma 5.18 we get that it is an isomorphism in **fClus** and we are done.  $\square$

## 5.5 Limits and colimits in $\mathbf{fClus}$

In Section 4.1.3 we defined limits and colimits in an arbitrary category and briefly discussed certain special kinds of such: products and equalizers and, dually, coproducts and coequalizers. An arbitrary category is complete, i.e. has all small limits, if and only if it has all small products and equalizers. Dually, a category is cocomplete, i.e. it has all small colimits, if and only if it has all small coproducts and coequalizers. In Theorem 5.20 we show that our category  $\mathbf{fClus}$  does not, in general, have products and does not, in general, have coequalizers and so it is neither complete nor cocomplete. We note here that the proof of Theorem 5.20 below uses forward reference to Theorem 5.33. This is allowed since the proof of Theorem 5.33 does not use Theorem 5.20.

**Theorem 5.20.** *The category  $\mathbf{fClus}$  is neither complete nor cocomplete.*

*Proof.* If the category  $\mathbf{fClus}$  was cocomplete then coequalizers would exist. However, let us consider the seeds

$$\Sigma_0 = \left( \{x_1, x_2, x_3\}, \{x_1\}, x_1 \begin{array}{c} \nearrow \boxed{x_2} \\ \searrow \boxed{x_3} \end{array} \right) \quad \text{and} \quad \Sigma_1 = (\{y\}, \emptyset, \boxed{y})$$

and the parallel freezing rooted cluster morphisms defined by the algebraic extension of:

$$f : \begin{cases} \mathcal{A}(\Sigma_0) \rightarrow \mathcal{A}(\Sigma_1) \\ x_i \mapsto y \text{ for } i = 1, 2, 3 \end{cases} \quad \text{and} \quad g : \begin{cases} \mathcal{A}(\Sigma_0) \rightarrow \mathcal{A}(\Sigma_1) \\ x_i \mapsto y \text{ for } i = 1, 2, \\ x_3 \mapsto 0. \end{cases}$$

The maps  $f$  and  $g$  are freezing rooted cluster morphisms by Theorem 5.33. Assume for contradiction that there exists a coequalizer for  $f$  and  $g$ . That is, there exists a rooted cluster algebra  $\mathcal{A}(\Sigma := (X, ex, B))$  with a freezing rooted cluster morphism  $\pi : \mathcal{A}(\Sigma_1) \rightarrow \mathcal{A}(\Sigma)$  such that  $\pi \circ f = \pi \circ g$  and it is universal with this property. First, we observe that  $\mathcal{A}(\Sigma_0) = \mathbb{Z}[x_1, x_2, x_3, \frac{x_2+x_3}{x_1}]$ . But then  $f(\frac{x_2+x_3}{x_1}) = 2$  and  $g(\frac{x_2+x_3}{x_1}) = 1$  and we have that

$\pi(f(\frac{x_2+x_3}{x_1})) = \pi(g(\frac{x_2+x_3}{x_1}))$ . But this means that  $\pi(2) = \pi(1)$ , a contradiction. Thus, there is no coequalizer for  $f$  and  $g$  in **fClus** and so **fClus** is not cocomplete.

Let us now show that, again by the means of a counter example, the category **fClus** is not complete. If it was, then products would exist in **fClus**. We show that the same pair of rooted cluster algebras has no product in **fClus** by using the strategy from the proof of [2, Proposition 5.4].

Let us consider the rooted cluster algebras associated with the seeds  $\Sigma_0 = (\{z_0\}, \emptyset, \boxed{z_0})$  and  $\Sigma_1 = (\{z_1\}, \emptyset, \boxed{z_1})$ , so that  $\mathcal{A}(\Sigma_i) = \mathbb{Z}[z_i]$  for  $i = 0, 1$ . We will assume for contradiction that there exists a product of  $\mathcal{A}(\Sigma_0)$  and  $\mathcal{A}(\Sigma_1)$  in **fClus**. That is, that there exists a rooted cluster algebra  $\mathcal{A}(\Sigma := (X, ex, B))$  equipped with a pair of freezing rooted cluster morphisms  $p_0 : \mathcal{A}(\Sigma) \rightarrow \mathcal{A}(\Sigma_0)$  and  $p_1 : \mathcal{A}(\Sigma) \rightarrow \mathcal{A}(\Sigma_1)$  and it is universal with this property. Let us consider a rooted cluster algebra associated with the seed  $\Sigma' = (\{x\}, \emptyset, \boxed{x})$ , that is,  $\mathcal{A}(\Sigma') = \mathbb{Z}[x]$ , and let  $f_i : \mathcal{A}(\Sigma') \rightarrow \mathcal{A}(\Sigma_i)$  be the ring homomorphism defined by sending  $x$  to  $z_i$  for  $i = 0, 1$ . Then  $f_i$  satisfies (FCM1) and (FCM2) and in the absence of biadmissible sequences it also satisfies (FCM3) trivially and so is a freezing rooted cluster morphism for  $i = 0, 1$ . Since  $\mathcal{A}(\Sigma)$  is the product of  $\mathcal{A}(\Sigma_0)$  and  $\mathcal{A}(\Sigma_1)$  in **fClus**, there exists a unique freezing rooted cluster morphism  $h : \mathcal{A}(\Sigma') \rightarrow \mathcal{A}(\Sigma)$  that makes the following diagram, which we will refer to as  $\mathcal{D}_0$  throughout the rest of this proof, commute.

$$\begin{array}{ccc}
 & \mathcal{A}(\Sigma') & \\
 & \downarrow h & \\
 \mathcal{A}(\Sigma_0) & \mathcal{A}(\Sigma) & \mathcal{A}(\Sigma_1) \\
 \swarrow f_0 & & \searrow f_1 \\
 \mathbb{Z}[z_0] & & \mathbb{Z}[z_1] \\
 \nwarrow p_0 & & \nearrow p_1
 \end{array}$$

In particular, for any  $i \in \{0, 1\}$ , there exists  $x_i \in X \setminus ex$  such that  $p_i(x_i) = z_i$ .

On the other hand, let us consider the seed  $\Sigma'' = (\{y_0, y_1\}, \emptyset, \boxed{y_0} \boxed{y_1})$ , so that  $\mathcal{A}(\Sigma'') = \mathbb{Z}[y_0, y_1]$ , and let  $g_i : \mathcal{A}(\Sigma'') \rightarrow \mathcal{A}(\Sigma_i)$  be a ring homomorphism defined by  $g_i(y_j) = \delta_{ij} z_j$ , where  $\delta_{ij}$  is the Kronecker symbol, for  $i = 0, 1$ . Then for any  $i \in \{0, 1\}$ ,  $g_i$  satisfies (FCM1), (FCM2) and (FCM3) and so it is a freezing rooted cluster morphism. Again, since  $\mathcal{A}(\Sigma)$  is the product of  $\mathcal{A}(\Sigma_0)$  and  $\mathcal{A}(\Sigma_1)$  in **fClus** there exists a unique freezing rooted cluster morphism  $h' : \mathcal{A}(\Sigma'') \rightarrow \mathcal{A}(\Sigma)$  that makes the following diagram, denoted by  $\mathcal{D}_1$ , commute.

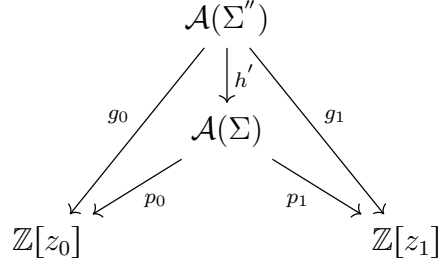

Now for any  $i \in \{0, 1\}$ , because  $h'$  satisfies (FCM2), we have that  $h'(y_i) = x_i$  for some  $x_i \in X \setminus ex$  such that  $p_i(x_i) = z_i$ . Suppose that there are two  $x_i, x'_i \in X \setminus ex$  such that  $p_i(x_i) = p_i(x'_i) = z_i$ . Then the ring homomorphism  $h'' : \mathcal{A}(\Sigma'') \rightarrow \mathcal{A}(\Sigma)$  that sends  $y_i$  to  $x'_i$  is a freezing rooted cluster morphism that makes  $\mathcal{D}_1$  commute and by uniqueness  $h' = h''$  and so  $x_i = x'_i$  for  $i = 0, 1$ . Moreover, since we have that  $(p_0 \circ h')(y_0) = z_0$  and  $(p_0 \circ h')(y_1) = 0$ , it follows that  $h'(y_0) \neq h'(y_1)$ . To sum up, there are exactly two distinct elements  $h'(y_0) = x_0$  and  $h'(y_1) = x_1$  in  $X \setminus ex$  such that  $p_0(x_0) = z_0$ ,  $p_1(x_0) = 0$ ,  $p_1(x_1) = 0$  and  $p_1(x_1) = z_1$ .

Now let us go back to the rooted cluster algebra  $\mathcal{A}(\Sigma')$  where  $\Sigma' = (\{x\}, \emptyset, \boxed{x})$  and let us again consider the freezing rooted cluster morphism  $f_i : \mathcal{A}(\Sigma') \rightarrow \mathcal{A}(\Sigma_i)$  that sends  $x$  to  $z_i$  for  $i = 0, 1$  and the unique freezing rooted cluster morphism  $h : \mathcal{A}(\Sigma') \rightarrow \mathcal{A}(\Sigma)$  that makes  $\mathcal{D}_0$  commute. Due to what we have established so far, we must have that  $h(x) = x_0$  by the commutativity of the left triangle in  $\mathcal{D}_0$  and also that  $h(x) = x_1$  by the commutativity of the right triangle in  $\mathcal{D}_0$ , which gives us a contradiction. Finally, we deduce that the rooted cluster algebras  $\mathcal{A}(\Sigma_0)$  and  $\mathcal{A}(\Sigma_1)$  have no product in the category **fClus**.  $\square$

## 5.6 Freezing morphisms

In this section we study freezing rooted cluster morphisms that send exchangeable variables to frozen variables. Defining such maps, which we will often refer to simply as *freezing morphisms*, in the most naive way leads to some obvious errors. Let us look at the following example.

**Example 5.21.** Consider the seeds

$$\Sigma = (\{x_1, x_2\}, \{x_1, x_2\}, x_1 \longrightarrow x_2)$$

and

$$\Sigma' = (\{y_1, y_2\}, \{y_1\}, y_1 \longrightarrow \boxed{y_2})$$

with associated cluster algebras

$$\mathcal{A}(\Sigma) = \mathbb{Z} \left[ x_1, x_2, \frac{x_1 + 1}{x_2}, \frac{x_2 + 1}{x_1}, \frac{x_1 + x_2 + 1}{x_1 x_2} \right]$$

and

$$\mathcal{A}(\Sigma') = \mathbb{Z} \left[ y_1, y_2, \frac{y_2 + 1}{y_1} \right].$$

A map sending  $x_1$  to  $y_1$  and  $x_2$  to  $y_2$  does not extend to a ring homomorphism from  $\mathcal{A}(\Sigma)$  to  $\mathcal{A}(\Sigma')$  since we would need to map  $\frac{x_1+1}{x_2}$  to  $\frac{y_1+1}{y_2}$ , which does not lie in  $\mathcal{A}(\Sigma')$ .

We can see that in order to "freeze" exchangeable variables some additional structure is needed. To deal with this issue we will, informally speaking, have to connect an exchangeable variable that we are willing to "freeze" with some frozen variables. Doing so will allow us to define a class of freezing rooted cluster morphisms between non-isomorphic cluster algebras of different finite types. Where desirable, we will also describe a geometric interpretation of freezing morphisms and discuss their possible root-theoretic reformulations.

A natural problem to consider is to characterize all freezing rooted cluster morphism that send exchangeable variables to frozen variables. Below we give an initial result in this direction.

**Proposition 5.22.** *Let  $\Sigma = (X, ex, B)$ ,  $\Sigma' = (X', ex', B')$  be seeds and let  $f : \mathcal{A}(\Sigma) \rightarrow \mathcal{A}(\Sigma')$  be a freezing rooted cluster morphism such that  $f(x) \in X' \setminus ex'$  and  $f(ex \setminus \{x\}) \subseteq ex'$  for some  $x \in ex$ . Then there exists  $y \in X \setminus ex$  such that  $b_{xy} \neq 0$ .*

*Proof.* We assume for contradiction that  $b_{xz} = 0$  for all  $z \in X \setminus ex$ . We then have that

$$\mu_x(x) = \frac{\prod_{\substack{z \in X; \\ b_{xz} > 0}} z^{b_{xz}} + \prod_{\substack{z \in X; \\ b_{xz} < 0}} z^{-b_{xz}}}{x} = \frac{\prod_{\substack{z \in ex; \\ b_{xz} > 0}} z^{b_{xz}} + \prod_{\substack{z \in ex; \\ b_{xz} < 0}} z^{-b_{xz}}}{x}.$$

Therefore,

$$f(\mu_x(x)) = \frac{\prod_{\substack{z \in ex; \\ b_{xz} > 0}} f(z)^{b_{xz}} + \prod_{\substack{z \in ex; \\ b_{xz} < 0}} f(z)^{-b_{xz}}}{f(x)}. \quad (9)$$

Now as  $f(x)$  is a frozen variable and  $f(z)$  is an exchangeable variable for every  $z \in ex \setminus \{x\}$  we have that  $f(z) \neq f(x)$  and so  $f(x)$  divides neither of the summands in the numerator on

the right hand side of the equation (9) above. Moreover, by the Laurent Phenomenon (see Section 2.1.5), every cluster variable of  $\mathcal{A}(\Sigma')$  and thus every element of the cluster algebra  $\mathcal{A}(\Sigma')$  is a Laurent polynomial in  $ex'$  with coefficients integer polynomials in the  $X' \setminus ex'$ . Thus  $f(\mu_x(x)) \notin \mathcal{A}(\Sigma')$ , a desired contradiction.  $\square$

### 5.6.1 Freezing morphisms between acyclic cluster algebras

Throughout the rest of this section we will restrict ourselves to working with so-called *acyclic* cluster algebras, which were first defined and studied by A. Berenstein, S. Fomin and A. Zelevinsky in [8]. In the skew-symmetric setting, these are the cluster algebras that arise from a quiver with no directed cycles between exchangeable vertices. They form a large class of cluster algebras that contains, for example, all cluster algebras of finite type. More importantly, the structure of acyclic cluster algebras is well-understood (see [8] for more details). Here we only provide sufficient, from the perspective of this thesis, amount of information on acyclic cluster algebras and refer the reader to [8], for a thorough exposition of this topic.

A quiver  $Q$  is called *acyclic* if it has no oriented cycles. For example, the quiver

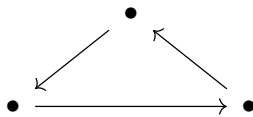

is not acyclic but the following one is.

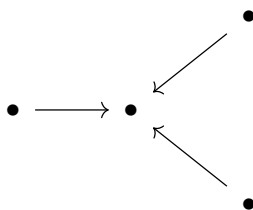

We recall that if  $\Sigma = (X, ex, B)$  is a seed then the principal part of  $B$  (cf. Definition 3.24) is denoted by  $\tilde{B}$ .

**Definition 5.23.** Let  $\Sigma = (X, ex, B)$  be a seed. We say that  $\Sigma$  is *acyclic* if the quiver  $Q_{\tilde{B}}$  is acyclic.



In other words, for a seed to be acyclic, it is only required that the full subquiver on the exchangeable vertices is acyclic. For instance, the seed

$$\Sigma = \left( \{x_1, x_2, x_3, x_4\}, \{x_1, x_2\}, x_1 \longrightarrow x_2 \begin{array}{c} \nearrow \boxed{x_3} \\ \searrow \boxed{x_4} \\ \downarrow \end{array} \right)$$

is acyclic, because the full subquiver  $x_1 \longrightarrow x_2$  on the exchangeable vertices  $x_1$  and  $x_2$  is acyclic.

A cluster algebra is acyclic if one of its seeds is. More formally:

**Definition 5.24.** ([8, §1]). Let  $\Sigma = (X, ex, B)$  be a seed. We call a cluster algebra  $\mathcal{A}(\Sigma)$  (respectively, rooted cluster algebra  $(\mathcal{A}(\Sigma), \Sigma)$ ) *acyclic* if there exists a seed  $\Sigma' \in \text{Mut}(\Sigma)$  that is acyclic.

Because every cluster algebra of finite type has a seed such that the quiver corresponding to the principle part of its exchange matrix is an orientation of a finite type Dynkin diagram, and since every such Dynkin diagram is a tree, it follows that every cluster algebra of finite type is acyclic.

We will need the following result for the proof of Theorem 5.33.

**Lemma 5.25.** ([8, Corollary 1.21]). Let  $\Sigma = (X, \{x_1, \dots, x_n\}, B)$  be a seed such that the cluster algebra  $\mathcal{A}(\Sigma)$  associated with  $\Sigma$  is acyclic. Then

$$\mathcal{A}(\Sigma) = \mathbb{Z}[X \cup \{x'_1, \dots, x'_n\}]$$

where  $x'_1, \dots, x'_n$  are given by (2) from Section 2.1.3.

Thus, an acyclic cluster algebra is generated by the cluster variables from the initial cluster together with the cluster variables obtained by a single mutation of the initial cluster in all possible directions.

We will now move onto constructing a family of freezing morphisms between acyclic rooted cluster algebras. As we saw at the beginning of this section, defining such maps in

the most trivial way causes problems and so we must make certain amendments. Let us start with the following definition.

**Definition 5.26.** Let  $\Sigma = (X, ex, B)$  be a seed and let  $x \in X$ . We call a cluster variable  $y \in X$  a *neighbour* of  $x$  (an *exchangeable neighbour* or a *frozen neighbour*, respectively) in  $\Sigma$ , if  $b_{xy} \neq 0$ . Moreover, if  $x \in ex$  and  $y \in X \setminus ex$  is such that  $b_{xy} \neq 0$  and  $b_{x'y} = 0$  for all  $x' \in ex \setminus \{x\}$ , we call  $y$  an *isolated frozen neighbour* of  $x$  in  $\Sigma$ .

**Example 5.27.** Let  $\Sigma = (\{x_i : 1 \leq i \leq 6\}, \{x_i : 1 \leq i \leq 4\}, B_Q = (b_{xy})_{x,y \in \{x_i : 1 \leq i \leq 6\}})$  be a seed where

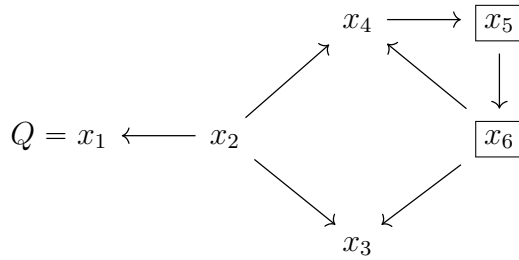

The exchangeable variables  $x_1$  and  $x_2$  have no frozen neighbours and so no isolated frozen neighbours. The exchangeable variable  $x_3$  has a frozen neighbour  $x_6$ , but  $x_6$  is not an isolated frozen neighbour of  $x_3$  since it is also connected to  $x_4$  in  $Q$  and  $x_4$  is another exchangeable variable of  $\Sigma$ . The exchangeable variable  $x_4$  is connected to two distinct frozen variables:  $x_5$  and  $x_6$ . Now,  $x_6$  is connected to  $x_3$  in  $Q$  and so  $x_6$  is not an isolated frozen neighbour of  $x_4$  in  $\Sigma$  since  $x_3$  is an exchangeable variable. Finally,  $x_5$  is an isolated frozen neighbour of  $x_4$  in  $Q$  since  $x_5$  is connected to  $x_4$  (and to a frozen variable  $x_6$ , which is allowed) but not to any other exchangeable variable of  $\Sigma$ .

For all  $x \in ex$  we set

$$\Delta_x^\Sigma := \{y \in X \setminus ex \mid y \text{ is an isolated frozen neighbour of } x \in ex \text{ in } \Sigma\}.$$

If the seed  $\Sigma$  is clear from context, we will write  $\Delta_x$  instead of  $\Delta_x^\Sigma$ .

**Definition 5.28.** Let  $\Sigma = (X, ex, B)$  and let  $x \in ex$ . If there exist  $y, z \in \Delta_x$ ,  $y \neq z$  with  $b_{xy} > 0$  and  $b_{xz} < 0$ , we call  $x$  a *freezeable variable* (or respectively, a *freezeable vertex*).

We call a seed which has freezeable variables a *freezeable seed*.

**Example 5.29.** Let  $\Sigma = (\{x_i : 1 \leq i \leq 6\}, \{x_i : 1 \leq i \leq 4\}, B_Q = (b_{xy})_{x,y \in \{x_i : 1 \leq i \leq 6\}})$  be a seed where

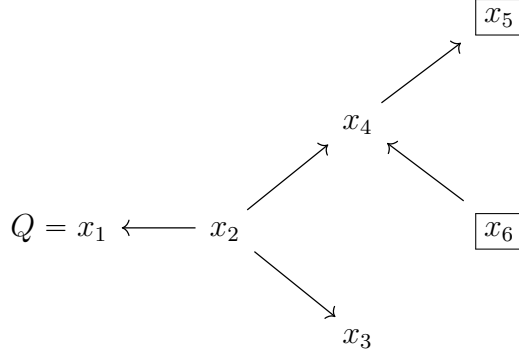

We notice that  $\Delta_{x_i} = \emptyset$  for  $i = 1, 2, 3$  and that  $\Delta_{x_4} = \{x_5, x_6\}$ . Moreover, as  $b_{x_4, x_5} = 1$  and  $b_{x_4, x_6} = -1$ , we have that  $x_4$  is a freezeable variable and so  $\Sigma$  is a freezeable seed. We can make any of the exchangeable variables  $x_i$  for  $i = 1, 2, 3$  freezeable by attaching to it a family  $\Delta_{x_i}$  of isolated frozen variables with at least one pair  $y, z \in \Delta_{x_i}$  such that  $b_{x_i, y} > 0$  and  $b_{x_i, z} < 0$ . We also notice that  $\Sigma$  is an acyclic seed since the full subquiver of  $Q$  on the exchangeable vertices is acyclic. Moreover, the full subquiver of  $Q$  on the exchangeable vertices is an (alternating) orientation of a Dynkin diagram of type  $D_4$  and so the cluster algebra  $\mathcal{A}(\Sigma)$  associated with  $\Sigma$  is an acyclic cluster algebra of finite type  $D_4$ .

**Remark 5.30.** An important source of freezeable seeds are the triangulations of convex polygons. To discuss this, let  $m \geq 4$  be an integer and let  $T_m$  be a triangulation of  $\mathcal{P}_m$ . We call a marked point  $\mathbf{v}$  of  $\mathcal{P}_m$  an *ear* of  $T_m$  if the internal arc that connects the marked points neighbouring  $\mathbf{v}$  is in  $T_m$ . We note that every triangulation of  $\mathcal{P}_m$  has at least two ears, for all  $m \geq 4$ .

Now let  $\Sigma_{T_m} = (X_{T_m}, ex_{T_m}, B^{T_m})$  be the seed corresponding to  $T_m$  and  $\mathbf{v}$  an ear of  $T_m$ . Let  $\mathbf{v}_1$  and  $\mathbf{v}_2$  be the marked points directly preceding and succeeding  $\mathbf{v}$  in an anticlockwise and a clockwise direction, respectively. For simplicity, we will denote by  $\gamma \in T_m$  the arc of  $\mathcal{P}_m$  that connects  $\mathbf{v}_1$  to  $\mathbf{v}_2$  and by  $\gamma_1$  and  $\gamma_2$  the boundary arcs of  $\mathcal{P}_m$  that connect  $\mathbf{v}$  to  $\mathbf{v}_1$  and  $\mathbf{v}$  to  $\mathbf{v}_2$ , respectively. The frozen variables  $x_{\gamma_1}, x_{\gamma_2} \in X_{T_m}$  are the only isolated frozen neighbours of  $x_\gamma \in ex_{T_m}$  and so  $|\Delta_{x_\gamma}| = 2$ . Moreover, since  $b_{x_\gamma, x_{\gamma_1}}^{T_m} = 1$  and  $b_{x_\gamma, x_{\gamma_2}}^{T_m} = -1$  it follows that  $x_\gamma$  is a freezeable variable. Thus, an arbitrary triangulation of  $\mathcal{P}_m$  gives rise to a freezeable seed in this way. Similar construction can be used for other marked surfaces (cf. Example 5.36 and Example 5.37).

Now, let  $\Sigma^* = (X, ex, B)$  be a freezeable seed and let  $x \in ex$  be freezeable. We will denote by  $\Sigma_x^*$  the seed

$$\Sigma_x^* = (X^*, ex^*, B^*),$$

where  $X^* = X \setminus \Delta_x$ ,  $ex^* = ex \setminus \{x\}$  and  $B^* = (b_{yz}^*)_{y,z \in X \setminus \Delta_x}$  with  $b_{yz}^* = b_{yz}$ . We note that if  $\Sigma^*$  is acyclic then so is  $\Sigma_x^*$ .

**Example 5.31.** Let  $\Sigma^* = \Sigma$ , where  $\Sigma$  is the seed we considered in Example 5.29. Then  $\Sigma_{x_4}^* = (\{x_1, x_2, x_3, x_4\}, \{x_1, x_2, x_3\}, B_{Q'})$ , where

$$Q' = \begin{array}{ccccc} & & \boxed{x_4} & & \\ & & \uparrow & & \\ x_1 & \longleftarrow & x_2 & \longrightarrow & x_3 \end{array}$$

and the cluster algebra  $\mathcal{A}(\Sigma_{x_4}^*)$  is of finite Dynkin type  $A_3$ .

We are now ready to introduce a family of morphisms that are based on the idea of sending an exchangeable variable to a frozen variable and the idea of specializing certain isolated frozen neighbours to integers. In Section 5.6.3 we show that the maps  $f_{m,m-1}^{p,q}$  (see Definition 4.22), for  $p, q \in \{0, 1\}$ , coincide with suitably defined algebraic extensions of the maps from the Definition 5.32 below, thus we can view the (algebraic extensions of) maps from Definition 5.32 as a generalization of the morphisms  $f_{m,m-1}^{p,q}$  that were defined between cluster algebras associated with convex polygons.

Fix  $p, q \in \{0, 1\}$ .

**Definition 5.32.** Let  $\Sigma^* = (X, ex, B)$  be a freezeable seed, let  $x \in ex$  be freezeable and let  $\Sigma_x^* = (X^*, ex^*, B^*)$ . We define  $Fr_x^{p,q}$  to be the following map.

$$Fr_x^{p,q} = \begin{cases} X \rightarrow X^* \cup \{0\} \\ y \mapsto y \text{ if } y \notin \Delta_x, \\ y \mapsto px \text{ if } y \in \Delta_x \text{ and } b_{xy} > 0, \\ y \mapsto qx \text{ if } y \in \Delta_x \text{ and } b_{xy} < 0. \end{cases} \quad (10)$$

Our next results shows that the above map induces a freezing rooted cluster morphism between acyclic rooted cluster algebras.

**Theorem 5.33.** *Let  $\Sigma^* = (X, ex, B)$  be a freezeable seed such that there exists an acyclic seed  $\Sigma' \in \text{Mut}(\Sigma^*)$ . Let  $x \in ex$  be a freezeable variable and let  $\Sigma_x^* = (X^*, ex^*, B^*)$ . Then the ring homomorphism  $f : \mathcal{A}(\Sigma^*) \rightarrow \mathcal{F}_{\Sigma_x^*}$  defined as the algebraic extension of the map  $Fr_x^{p,q}$  induces a freezing rooted cluster morphism from  $\mathcal{A}(\Sigma^*)$  to  $\mathcal{A}(\Sigma_x^*)$ .*

*Proof.* To prove the statement we must show that  $\text{Im}(f) \subseteq \mathcal{A}(\Sigma_x^*)$  and that  $f$  satisfies axioms (FCM1), (FCM2) and (FCM3). That  $f$  satisfies (FCM1) and (FCM2) is true by construction. Next, let us show that  $\text{Im}(f) \subseteq \mathcal{A}(\Sigma_x^*)$ . By Lemma 5.25 we only need to show that  $f(X \cup \{\mu_y(y) : y \in ex\}) \subset \mathcal{A}(\Sigma_x^*)$ . This is automatically true for all cluster variables from  $X$ . Now, let  $y \in ex \setminus \{x\}$ . Then

$$\begin{aligned} f(\mu_y(y)) &= \frac{f\left(\prod_{\substack{z \in X \setminus \Delta_x, \\ b_{yz} > 0}} y^{b_{yz}} + \prod_{\substack{z \in X \setminus \Delta_x, \\ b_{yz} < 0}} y^{-b_{yz}}\right)}{f(y)} \\ &= \frac{\prod_{\substack{z \in X^*, \\ b_{yz}^* > 0}} y^{b_{yz}^*} + \prod_{\substack{z \in X^*, \\ b_{yz}^* < 0}} y^{-b_{yz}^*}}{y} \\ &= \mu_{y, \Sigma_x^*}(y) \in \mathcal{A}(\Sigma_x^*). \end{aligned}$$

Moreover, we have

$$\begin{aligned} \mu_x(x) &= \frac{\prod_{\substack{y \in X; \\ b_{xy} > 0}} y^{b_{xy}} + \prod_{\substack{y \in X; \\ b_{xy} < 0}} y^{-b_{xy}}}{x} \\ &= \frac{\prod_{\substack{y \in \Delta_x; \\ b_{xy} > 0}} y^{b_{xy}} \prod_{\substack{y \in X \setminus \Delta_x; \\ b_{xy} > 0}} y^{b_{xy}} + \prod_{\substack{y \in \Delta_x; \\ b_{xy} < 0}} y^{-b_{xy}} \prod_{\substack{y \in X \setminus \Delta_x; \\ b_{xy} < 0}} y^{-b_{xy}}}{x}. \end{aligned}$$

We note here that both products

$$\prod_{\substack{y \in \Delta_x; \\ b_{xy} > 0}} y^{b_{xy}} \quad \text{and} \quad \prod_{\substack{y \in \Delta_x; \\ b_{xy} < 0}} y^{-b_{xy}}$$

are non-empty. But then we have that

$$\begin{aligned}
f(\mu_x(x)) &= \frac{f\left(\prod_{\substack{y \in \Delta_x; \\ b_{xy} > 0}} y^{b_{xy}} \prod_{\substack{y \in X \setminus \Delta_x; \\ b_{xy} > 0}} y^{b_{xy}}\right) + f\left(\prod_{\substack{y \in \Delta_x; \\ b_{xy} < 0}} y^{-b_{xy}} \prod_{\substack{y \in X \setminus \Delta_x; \\ b_{xy} < 0}} y^{-b_{xy}}\right)}{f(x)} \\
&= px^{k-1} \prod_{\substack{y \in X \setminus \Delta_x; \\ b_{xy} > 0}} f(y)^{b_{xy}} + qx^{k'-1} \prod_{\substack{y \in X \setminus \Delta_x; \\ b_{xy} < 0}} f(y)^{-b_{xy}},
\end{aligned}$$

where

$$k = \sum_{\substack{y \in \Delta_x; \\ b_{xy} > 0}} b_{xy} \geq 1 \text{ and where } k' = - \sum_{\substack{y \in \Delta_x; \\ b_{xy} < 0}} b_{xy} \geq 1.$$

Since  $f(y) = y \in X^*$  for all  $y \in X \setminus \Delta_x$ , it follows that  $f(\mu_x(x)) \in \mathcal{A}(\Sigma_x^*)$ , as required.

It is now left to show that  $f$  satisfies (FCM3). We will break down this problem into a list of a few smaller statements that together will give us the desired result. We fix  $(x_1, \dots, x_l)$  to be a  $\Sigma^*$ -admissible sequence such that  $x_i \neq x$  for all  $1 \leq i \leq l$ . Moreover, we set  $\tilde{\Sigma}^* := \mu_{x_l} \circ \dots \circ \mu_{x_1}(\Sigma^*)$  and if in addition  $(f(x_1), \dots, f(x_l))$  happens to be  $\Sigma_x^*$ -admissible then we set  $\tilde{\Sigma}_x^* := \mu_{f(x_l)} \circ \dots \circ \mu_{f(x_1)}(\Sigma_x^*)$ . Let  $\tilde{\Sigma}^* = (\tilde{X}, \tilde{e}\tilde{x}, \tilde{B})$ ,  $\tilde{\Sigma}_x^* = (\tilde{X}_x, \tilde{e}\tilde{x}_x, \tilde{B}_x)$  and let  $\tilde{x} \in \tilde{e}\tilde{x} \setminus \{x\}$ .

- (i) First we show that  $\tilde{b}_{\tilde{x}y} = 0$  for every  $y \in \Delta_x$ . We do this by induction on the length  $l$  of the  $\Sigma^*$ -admissible sequence. For  $l = 0$  the claim is true by definition. Now assume it is true for all  $\Sigma^*$ -admissible sequences of length at most  $l \geq 0$ . Let  $\tilde{B}'$  be the exchange matrix of the seed  $\mu_{\tilde{x}}(\tilde{\Sigma}^*)$  and let  $y \in \Delta_x \subseteq \tilde{X}$ . Then

$$\tilde{b}'_{\tilde{x}y} = -\tilde{b}_{\tilde{x}y} = 0,$$

by the induction hypothesis. Moreover, for  $\tilde{z} \in \tilde{e}\tilde{x} \setminus \{x\}$  such that  $\tilde{z} \neq \tilde{x}$  we have that

$$\tilde{b}'_{\tilde{z}y} = \tilde{b}_{\tilde{z}y} + \frac{1}{2}(|\tilde{b}_{\tilde{z}\tilde{x}}|\tilde{b}_{\tilde{x}y} + \tilde{b}_{\tilde{z}\tilde{x}}|\tilde{b}_{\tilde{x}y}|) = 0,$$

which is, again, true by the induction hypothesis and we are done.

- (ii) Now, due to the Laurent Phenomenon (cf. Section 2.1.5) we have that  $\tilde{x}$  is a Laurent Polynomial over  $\mathbb{Z}$  in the variables from  $X$ . We claim that  $\tilde{x}$  is in fact a Laurent polynomial in  $X \setminus \Delta_x$ . Again, we prove this by induction on  $l$ . For  $l = 0$  the claim is

trivially true. Assume it is true for all  $\Sigma^*$ -admissible sequences of length at most  $l \geq 0$ . We have that

$$\begin{aligned} \mu_{\tilde{x}}(\tilde{x}) &= \prod_{\substack{y \in \tilde{X}; \\ b_{\tilde{x}y} > 0}} y^{\tilde{b}_{\tilde{x}y}} + \prod_{\substack{y \in \tilde{X}; \\ b_{\tilde{x}y} < 0}} y^{-\tilde{b}_{\tilde{x}y}} \\ &= \prod_{\substack{y \in \tilde{X} \setminus \Delta_x; \\ b_{\tilde{x}y} > 0}} y^{\tilde{b}_{\tilde{x}y}} + \prod_{\substack{y \in \tilde{X} \setminus \Delta_x; \\ b_{\tilde{x}y} < 0}} y^{-\tilde{b}_{\tilde{x}y}}, \end{aligned}$$

where the second equality is true by (i). The result follows from the induction hypothesis.

Because  $f$  acts as the identity on the variables from  $X \setminus \Delta_x$ , it follows that  $f(\tilde{x}) = \tilde{x}$  for all  $\tilde{x} \in e\tilde{x} \setminus \{x\}$ .

(iii) Next we want to show that  $f(\tilde{x})$  is in fact an exchangeable variable in  $\tilde{\Sigma}_x^*$ . We do this by induction on the length  $l$  of the  $\Sigma^*$ -admissible sequence  $(x_1, \dots, x_l)$ . It is true for  $l = 0$  as every  $x' \in e\tilde{x} \setminus \{x\}$  is sent by  $f$  to an exchangeable variable in  $X \setminus \Delta_x$ . Assume now that the claim is true for all  $\Sigma^*$ -admissible sequences of length at most  $l \geq 0$ . We want to show that  $f(\tilde{x}) \in e\tilde{x}_x$ . First, we have that  $\tilde{x} = \mu_{x_l} \circ \dots \circ \mu_{x_1}(z)$ , for some  $z \in e\tilde{x} \setminus \{x\}$ . It follows from the induction hypothesis that  $f(x_i)$  are exchangeable variables, in their respective seeds, for all  $1 \leq i \leq l$ . Moreover, by (ii) we have that  $f(x_i) = x_i$  for all  $1 \leq i \leq l$  and that  $f(z) = z$  and so  $\tilde{y} := \mu_{x_l} \circ \dots \circ \mu_{x_1}(z) \in e\tilde{x}_x$ . Thus we have that  $(x_1, \dots, x_l)$  is a  $(f, \Sigma^*, \Sigma_x^*)$ -admissible sequence. From (i) and the definition of matrix mutation (cf. equation (3)) we have that  $\tilde{B}[\tilde{X} \setminus \Delta_x] = \tilde{B}_x$  and so  $\tilde{y} = \tilde{x} = f(\tilde{x})$ , proving the claim.

Next, we want to characterize  $(f, \Sigma^*, \Sigma_x^*)$ -biadmissible sequences.

(iv) We show that  $(f(x_1), \dots, f(x_l))$  is  $\Sigma_x^*$ -admissible if and only if  $x_i \neq x$  for all  $1 \leq i \leq l$ . The direction  $(\Leftarrow)$  is true by (iii) above. For the opposite direction, assume for a contradiction that  $x_i = x$  for some  $1 \leq i \leq l$ . But then  $f(x_i) = x$  is a frozen variable and so  $(f(x_1), \dots, f(x_l))$  cannot be  $\Sigma_x^*$ -admissible, giving us the desired contradiction.

Finally, we show below that  $f$  satisfies (FCM3).

(v) Let  $(x_1, \dots, x_l)$  be a  $(f, \Sigma^*, \Sigma_x^*)$ -biadmissible sequence and let  $y \in X$  be such that  $f(y) \in X \setminus \Delta_x$ . We will show that this implies that

$$f(\mu_{x_l} \circ \dots \circ \mu_{x_1}(y)) = \mu_{f(x_l)} \circ \dots \circ \mu_{f(x_1)}(f(y)).$$

First, if  $y = x$  then

$$\begin{aligned} f(\mu_{x_l} \circ \dots \circ \mu_{x_1}(y)) &= f(x) = x \\ &= \mu_{f(x_l)} \circ \dots \circ \mu_{f(x_1)}(x) \\ &= \mu_{f(x_l)} \circ \dots \circ \mu_{f(x_1)}(f(x)), \end{aligned}$$

where the first and the third equality follow from (iv) and the fact that  $x$  is a frozen variable in  $\mathcal{A}(\Sigma_x^*)$ , respectively.

Now, if  $y \in X \setminus \{ex\}$  with  $f(y) \in X_x$  then

$$\begin{aligned} f(\mu_{x_l} \circ \dots \circ \mu_{x_1}(y)) &= f(y) = y \\ &= \mu_{f(x_l)} \circ \dots \circ \mu_{f(x_1)}(y) \\ &= \mu_{f(x_l)} \circ \dots \circ \mu_{f(x_1)}(f(y)), \end{aligned}$$

where the first and the third equality are true because  $y$  is a frozen variable in both  $\mathcal{A}(\Sigma^*)$  and  $\mathcal{A}(\Sigma_x^*)$ .

Finally, let  $y \in ex \setminus \{x\}$ . Then  $f(y) = y \in ex \setminus \{x\}$ . Let  $\tilde{x} = \mu_{x_l} \circ \dots \circ \mu_{x_1}(y)$ . Then we have that  $f(\tilde{x}) = \tilde{x}$ . Moreover, we have by (iii) that  $f(\tilde{x}) \in \tilde{e}x_x$ . We also have that  $f(x_i)$  are exchangeable variables, in their respective seeds, for all  $1 \leq i \leq l$ , since  $(x_1, \dots, x_l)$  is  $(f, \Sigma^*, \Sigma_x^*)$ -biadmissible. Then from (iv) we have that  $x_i \neq x$  for all  $1 \leq i \leq l$  and we also know that  $f(x_i) = x_i$  for all  $1 \leq i \leq l$ . Moreover,  $f(y) = y \in ex \setminus \{x\}$  and so

$$\mu_{f(x_l)} \circ \dots \circ \mu_{f(x_1)}(f(y)) = \mu_{x_l} \circ \dots \circ \mu_{x_1}(y) \in \tilde{e}x_x.$$

Now from (i) and the definition of matrix mutation we have that, for any  $(\Sigma^*, \Sigma_x^*, f)$ -biadmissible sequence  $(x_1, \dots, x_l)$ ,  $\tilde{B}[\tilde{X} \setminus \Delta_x] = \tilde{B}_x$  and so  $\mu_{f(x_l)} \circ \dots \circ \mu_{f(x_1)}(f(y)) = \tilde{x}$ , which proves the claim. □



**Remark 5.34.** We notice that given any Dynkin diagram, we can easily construct a freezeable seed from it, in the most intuitive way. The construction goes as follows. We pick a vertex of a Dynkin diagram and attach to one of its vertices two new distinct vertices using arrows: one to and one from the previously selected vertex, and then pick an orientation for each of the remaining edges. This gives us a quiver (or, a valued quiver) from which we construct a seed, a freezeable seed, with cluster variables corresponding to its vertices with the exchangeable variables corresponding to vertices from the initial Dynkin diagram. Now, due to Theorem 5.33, this enables us to construct freezing rooted cluster morphisms from cluster algebras of finite Dynkin type. Furthermore, if the underlying graph of the quiver of the seed obtained from the freezeable seed constructed from a Dynkin diagram in the way explained above by freezing freezeable variables and removing their isolated frozen neighbours is of finite Dynkin type, then Theorem 5.33 provides us with a recipe for constructing freezing rooted cluster morphisms between cluster algebras of finite Dynkin types. Below in Example 5.35 we give a couple of concrete examples of constructing a freezeable seed from a Dynkin diagram of type  $E_6$  and of type  $D_6$  as well as the seeds obtained by freezing the freezeable variables in the constructed seeds. A similar procedure of adjoining two (or more) additional frozen vertices in order to make an exchangeable variable freezeable can be applied to any quiver  $Q$ . Moreover, if this quiver is mutation equivalent to an acyclic quiver then by Theorem 5.33 there exist  $p, q$ -dependent freezing rooted cluster morphisms from a rooted cluster algebra associated with a seed  $\Sigma^*$  which has  $Q$  with the additional two vertices and the additional two arrows as its quiver, to a rooted cluster algebra associated with a seed  $\Sigma_x^*$ , where  $x$  is an exchangeable variable corresponding to a freezeable vertex in the freezeable version of  $Q$ .

**Example 5.35.** The  $E_6$  Dynkin diagram

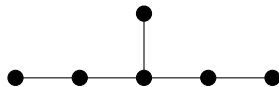

gives rise to a freezeable seed  $\Sigma^* = (\{x_i : 1 \leq i \leq 8\}, \{x_i : 1 \leq 6\}, Q_{E_6})$ , where

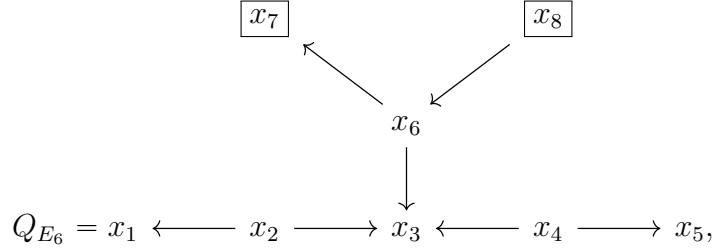

with  $x_6$  being the freezeable variable. We then have that  $\Sigma_{x_6}^* = (\{x_i : 1 \leq i \leq 6\}, \{x_i : 1 \leq i \leq 5\}, Q_{A_5})$ , where

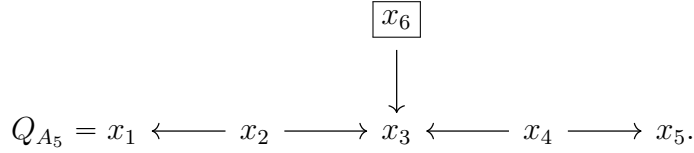

Similarly, the  $D_6$  Dynkin diagram

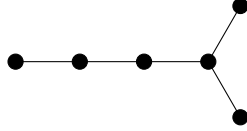

gives rise to a freezeable seed  $\Sigma^* = (\{x_i : 1 \leq i \leq 8\}, \{x_i : 1 \leq 6\}, Q_{D_6})$ , where

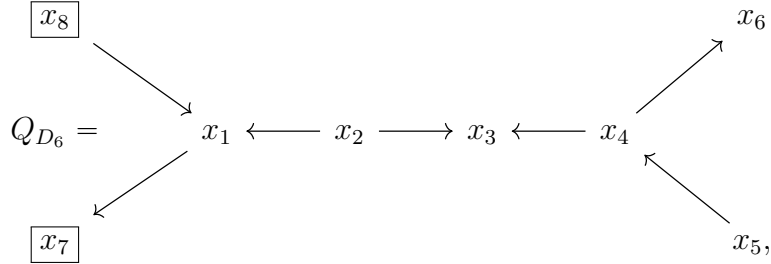

with  $x_1$  being a freezeable variable in this case. We then have that  $\Sigma_{x_1}^* = (\{x_i : 1 \leq i \leq 6\}, \{x_i : 2 \leq i \leq 6\}, Q_{D_5})$ , where

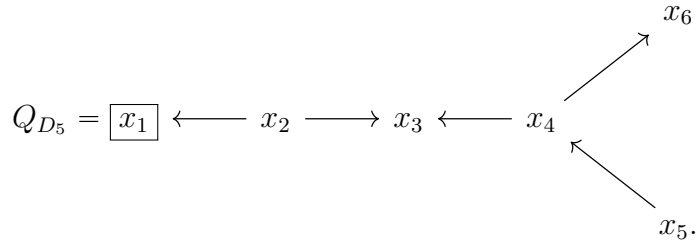

Then by Theorem 5.33 there exists a  $p, q$ -dependent family of freezing rooted cluster morphisms from a rooted cluster algebra of finite type  $E_6$  to a rooted cluster algebra of finite

type  $A_5$  and from a rooted cluster algebra of finite type  $D_6$  to a rooted cluster algebra of finite type  $D_5$ .

In Remark 5.30 we discussed how any triangulation of a convex polygon gives rise to a freezeable seed. We consider now different geometric examples. Throughout the rest of this section we denote by  $(i, j)$  the arc of a marked surface that connects the marked point labelled by  $i$  to a marked point labelled by  $j$  and by  $x_{i,j}$  its corresponding cluster variable.

**Example 5.36.** Let  $\Pi_9^1$  be a 9-gon with a single puncture in its interior. In other words,  $\Pi_9^1$  is a disk with 10 marked points, 9 of which lie on its boundary. Consider a triangulation  $T_9^1$  of  $\Pi_9^1$  shown in Figure 3. The quiver  $Q_{T_9^1}$  corresponding to the triangulation  $T_9^1$  is given by

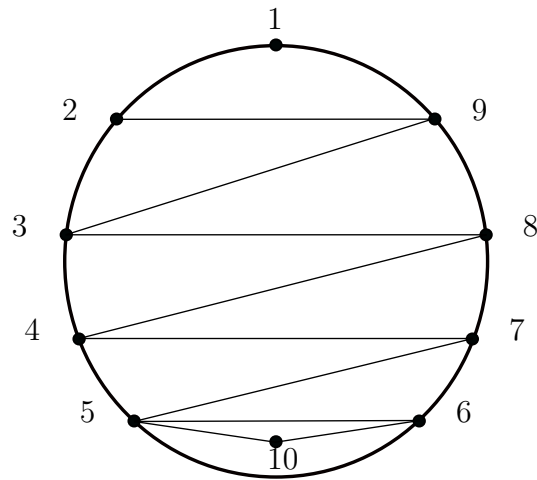
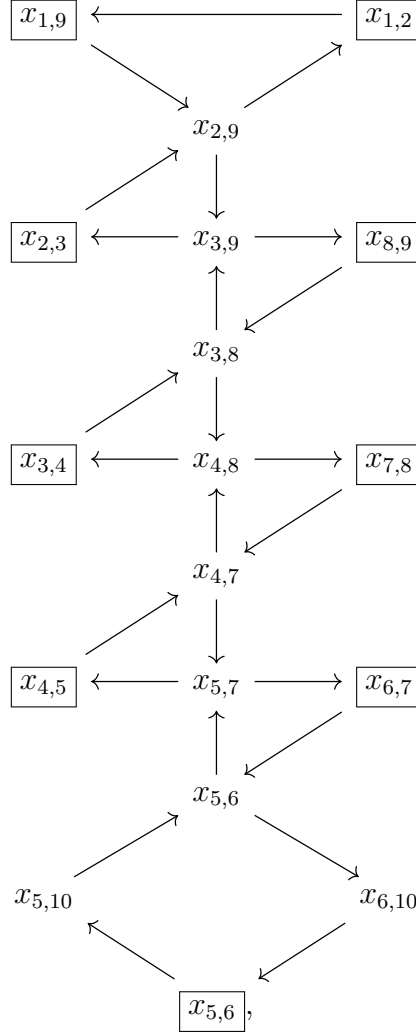

Figure 3: Triangulation  $T_9^1$  of a 9-gon with a single puncture.



where the vertices  $x_{i,j}$  of  $Q_{T_9^1}$  correspond to the arcs  $(i, j)$  of  $\Pi_9^1$ . We consider the seed

$$\Sigma = (\{x_\gamma \mid \gamma \text{ is an arc in } T_9^1\}, \{x_\gamma \mid \gamma \text{ is an internal arc in } T_9^1\}, Q_{T_9^1}).$$

We notice that  $\Sigma$  is freezeable with  $x_{2,9}$  its freezeable vertex. We let  $\Sigma^* = \Sigma$  and then we have

$$\Sigma_{x_{2,9}}^* = (\{x_\gamma \mid \gamma \text{ is an arc in } T_8^1\}, \{x_\gamma \mid \gamma \text{ is an internal arc in } T_8^1\}, Q_{T_8^1}).$$

where  $Q_{T_8^1}$  is the quiver corresponding to the triangulation  $T_8^1$  of  $\Pi_8^1$ , shown in Figure 4.

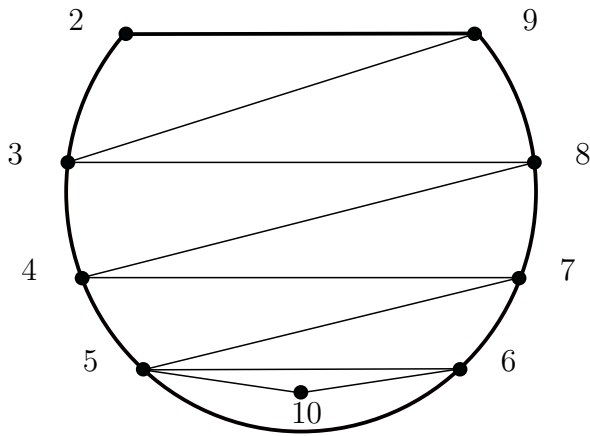
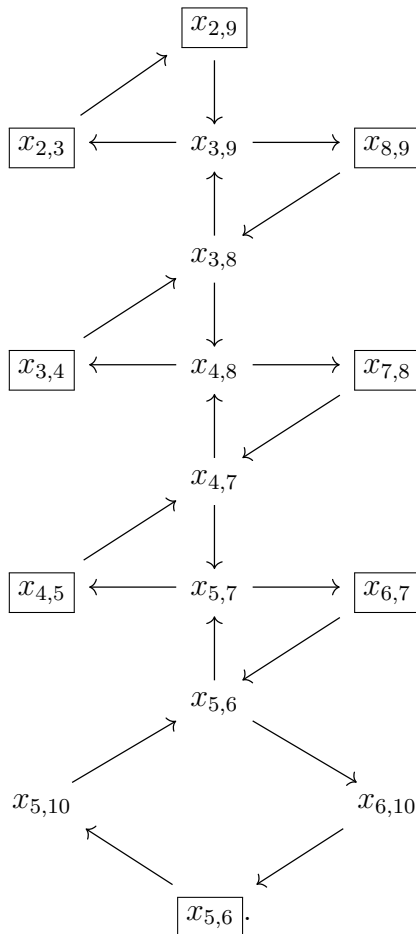

Figure 4: Triangulation  $T_8^1$  of a 8-gon with a single puncture.

That is,  $Q_{T_8^1}$  is given by



Now, let  $X$  and  $X^*$  denote the clusters in the seeds  $\Sigma^*$  and  $\Sigma_{x_{2,9}}^*$ , respectively, and let  $p = 1$  and  $q = 0$ . Then

$$Fr_{x_{2,9}}^{1,0} = \begin{cases} X \rightarrow X^* \cup \{0\} \\ x_{i,j} \mapsto x_{i,j} \text{ if } 2 \leq i < j \leq 9, \\ x_{1,2} \mapsto x_{2,9}, \\ x_{1,9} \mapsto 0, \end{cases}$$

and the algebraic extension of  $Fr_{x_{2,9}}^{1,0}$ , which we denote here by  $f$ , yields a freezing rooted cluster morphism  $f : \mathcal{A}(\Sigma^*) \rightarrow \mathcal{A}(\Sigma_{x_{2,9}}^*)$ , by Theorem 5.33. We notice that the full subquivers of  $Q_{T_9^1}$  and of  $Q_{T_8^1}$  on the exchangeable vertices are orientations of Dynkin diagram  $D_9$  and of Dynkin diagram  $D_8$ , respectively, and so  $f$  is a freezing rooted cluster morphism between cluster algebras of finite type  $D$  in this case. We also observe that, for example, the cluster variable corresponding to the arc connecting  $(1, 3)$  in  $\Pi_9^1$  is given by

$$\frac{x_{1,2}x_{3,9} + x_{2,3}x_{1,9}}{x_{2,9}}$$

and that

$$f\left(\frac{x_{1,2}x_{3,9} + x_{2,3}x_{1,9}}{x_{2,9}}\right) = x_{3,9}.$$

Let us then consider the triangle in  $\Pi_9^1$  on the marked points labelled by 1, 3 and 9 and the cluster variables  $x_{1,3}, x_{3,9}, x_{1,9}$  corresponding to its arcs. We notice that  $f$  sends  $x_{1,3}, x_{3,9}$  and  $x_{1,9}$  to  $x_{3,9}, x_{3,9}$  and 0, respectively. Thus,  $f$  *collapses* the triangle on the marked points labelled by 1, 3 and 9 to the arc  $(3, 9)$  in  $\Pi_8^1$  by collapsing the edge  $(1, 9)$ . Similarly,  $f$  acts on the top triangle of the triangulation  $T_9^1$  by *collapsing* it to the boundary arc  $(2, 9)$  of  $\Pi_8^1$ . On the other hand, let us consider the triangle in  $\Pi_9^1$  on the marked points labelled by 1, 2 and 3 and the cluster variables  $x_{1,2}, x_{2,3}, x_{1,3}$  corresponding to its arcs. We have that  $f$  sends  $x_{1,2}$  to  $x_{2,9}$ ,  $x_{2,3}$  to  $x_{2,3}$  and  $x_{1,3}$  to  $x_{3,9}$  and that the arcs corresponding to  $x_{2,9}$ ,  $x_{2,3}$  and  $x_{3,9}$  form a triangle in  $\Pi_8^1$ . Thus, informally speaking,  $f$  either *preserves* triangles or *collapses* them to arcs. More precisely, if a triangle in  $\Pi_9^1$  has the boundary arc  $(1, 9)$  as one of its edges then it gets *collapsed*, in a sense of the above examples, to an arc under the action of  $f$ . Else, if a triangle in  $\Pi_9^1$  does not have the boundary arc  $(1, 9)$  as one of its edges then it is *preserved*, again, in a sense of one of the above examples, under the action of  $f$ .

The notion of an inverse system and its inverse limit will play a key role in our discussions in Chapter 6. Most important for us, will be the inverse systems of freezing maps of triangulations of convex polygons. Before we move onto discussing those, we first consider in the Example 5.37 below, how one can construct an inverse system in the category **fClus** that has the cluster algebras arising from triangulations of once-punctured regular polygons as its objects and freezing morphisms as its bonding maps.

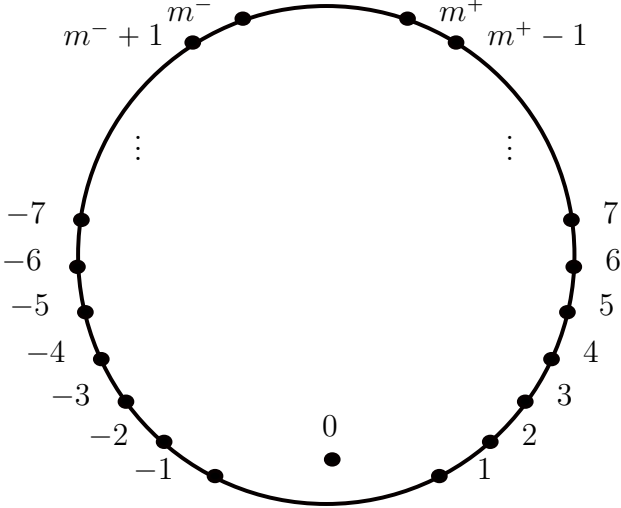
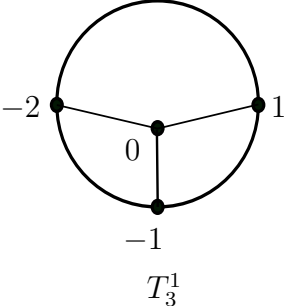
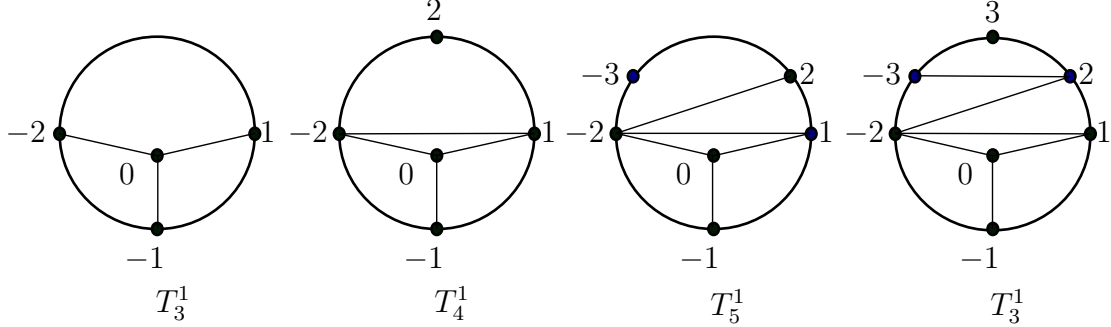

Figure 5: Labelling of marked points of a once-punctured  $(m - 1)$ -gon.

**Example 5.37.** Let  $m \geq 4$  be an integer and let  $m^- = -\lfloor \frac{m}{2} \rfloor$  and  $m^+ = \lfloor \frac{m-1}{2} \rfloor$ , where  $\lfloor - \rfloor$  is the usual floor function. Given an  $(m - 1)$ -gon  $\Pi_{m-1}^1$  with one puncture, we label its puncture with 0 and the remaining marked points cyclically anticlockwise with the integers  $m^-, m^- + 1, \dots, -1, 1, \dots, m^+ - 1, m^+$ , as shown in the Figure 5. We obtain a family  $\{T_{m-1}^1\}_{m \geq 4}$  of triangulations of  $\Pi_{m-1}^1$  as follows. We start with a triangulation  $T_3^1$  of  $\Pi_3^1$ , with  $T_3^1$  given by



We then obtain a triangulation  $T_4^1$  by adding a new marked point on the boundary arc connecting  $-2$  to  $1$  and then adding an (internal) arc that connects  $-2$  to  $1$ . We label the new marked point by  $2$ . Continuing in this way, a triangulation  $T_{m+1}^1$  of  $\Pi_{m+1}^1$  is obtained from a triangulation  $T_m^1$  of  $\Pi_m^1$  by adding a new marked point on the boundary arc joining  $m^-$  to  $m^+$ , labelling it with  $m^+ + 1$  if  $m$  is even and with  $m^- - 1$  if  $m$  is odd, and adding an internal arc that joins  $m^-$  to  $m^+$ , as shown in the figure below.



We note that for any integer  $m > 4$  the seed  $\Sigma_{T_{m-1}^1}$  associated with  $T_{m-1}^1$  is a freezeable seed where the exchangeable variable  $x_{(m-1)^-, (m-1)^+}$  corresponding to the arc connecting  $(m-1)^-$  to  $(m-1)^+$  is the unique freezeable variable in  $\Sigma_{T_{m-1}^1}$ . Moreover, letting  $\Sigma^* = \Sigma_{T_{m-1}^1}$  we get that  $\Sigma_{x_{(m-1)^-, (m-1)^+}}^* = \Sigma_{T_{m-2}^1}$  for all  $m > 4$ . Then by Theorem 5.33 there exists a  $p, q$ -dependent freezing rooted cluster morphism  $f_{m, m-1}^{p, q} : \mathcal{A}(\Sigma_{T_{m-1}^1}) \rightarrow \mathcal{A}(\Sigma_{T_{m-2}^1})$  for every  $m > 4$ . Thus, we obtain a family of inverse systems  $(\mathcal{A}(\Sigma_{T_{m-1}^1}), f_{m, m-1}^{p, q})_{m > 4}$ , in the category **fClus**, that consists of rooted cluster algebras of finite type  $D$  (see [15] for more details) and freezing morphisms between them.

### 5.6.2 Freezing morphisms, almost positive roots and cluster variables.

Let  $\Sigma^* = (X, ex, B)$  be a freezeable seed with  $x \in ex$  a freezeable vertex. If  $\Sigma^*$  and  $\Sigma_x^*$  give rise to cluster algebras of finite Dynkin type then in some cases we can reformulate freezing rooted cluster morphism from  $\mathcal{A}(\Sigma^*)$  to  $\mathcal{A}(\Sigma_x^*)$  using the correspondence between cluster variables and almost positive roots described in Theorem 3.29. Before we do this formally, let us first consider an example.

**Example 5.38.** Let  $\Sigma = (\{x_i : 1 \leq i \leq 6\}, \{x_i : 1 \leq i \leq 4\}, B_Q = (b_{xy})_{x, y \in \{x_i : 1 \leq i \leq 6\}})$  be a



seed where

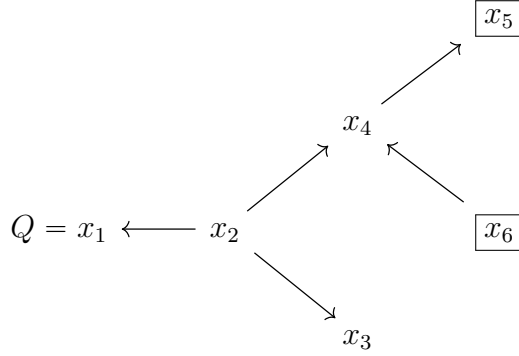

Then  $\Sigma$  is freezeable with  $x_4$  its only freezeable variable. Letting  $\Sigma^* = \Sigma$  we then have that  $\Sigma_{x_4}^* = (\{x_1, x_2, x_3, x_4\}, \{x_1, x_2, x_3\}, B_{Q'})$ , where

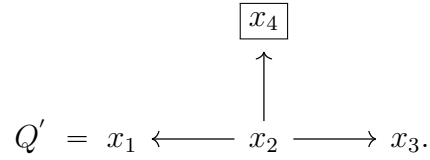

We have by Lemma 5.25 that

$$\mathcal{A}(\Sigma^*) = \mathbb{Z}\left[x_1, x_2, x_3, x_4, x_5, x_6, \frac{x_2 + 1}{x_1}, \frac{x_1 x_3 x_4 + 1}{x_2}, \frac{x_2 + 1}{x_3}, \frac{x_2 x_6 + x_5}{x_4}\right]$$

and that

$$\mathcal{A}(\Sigma_{x_4}^*) = \mathbb{Z}\left[x_1, x_2, x_3, x_4, \frac{x_2 + 1}{x_1}, \frac{x_1 x_3 x_4 + 1}{x_2}, \frac{x_2 + 1}{x_3}\right].$$

Denote by  $f^{1,0} : \mathcal{A}(\Sigma^*) \rightarrow \mathcal{A}(\Sigma_{x_4}^*)$  the freezing rooted cluster morphism defined to be the algebraic extension of

$$Fr_x^{1,0} = \begin{cases} \{x_i : 1 \leq i \leq 6\} \rightarrow \{x_i : 1 \leq i \leq 4\} \cup \{0\} \\ x_i \mapsto x_i \text{ for } 1 \leq i \leq 4, \\ x_5 \mapsto x_4, \\ x_6 \mapsto 0. \end{cases}$$

Making use of the bijection from Theorem 3.29, we have that  $f^{1,0}$  is the algebraic extension of

$$\begin{array}{ll} x[-\alpha_i] \mapsto x[-\alpha_i] \text{ for } i = 1, 2, 3 & x[-\alpha_4] \mapsto x_4 \\ x_5 \mapsto x_4 & x_6 \mapsto 0. \end{array}$$

Let us now return to the general theory. Fix  $m, n \in \mathbb{N}$  with  $m \geq n$ . Let

$$\Sigma^* = (X := \{x_1, \dots, x_n, x_{n+1}, \dots, x_m\}, \{x_1, \dots, x_n\}, B)$$

be a freezeable seed such that  $Q_{\tilde{B}}$  (recall that  $\tilde{B}$  is the principal part of the matrix  $B$ ; see Definition 3.24) is an alternating orientation of a Dynkin diagram  $\Gamma$  on  $n$  vertices and let  $\Phi$  be the corresponding root system with simple roots  $\Delta = \{\alpha_1, \dots, \alpha_n\}$ . We set  $\Delta^e := \Delta \cup \{\alpha_{n+1}, \dots, \alpha_m\}$ . We assume that  $x_n \in ex$  is freezeable with  $\Delta_{x_n} = \{x_{m-1}, x_m\}$  where  $b_{x_n, x_{m-1}} = 1$  and  $b_{x_n, x_m} = -1$ . Note that for

$$\Sigma_{x_n}^* = (X^* := \{x_1, \dots, x_n, x_{n+1}, \dots, x_{m-2}\}, \{x_1, \dots, x_{n-1}\}, B^*)$$

we have that  $Q_{\tilde{B}^*}$  is an alternating orientation of a disjoint union of Dynkin diagrams  $\Gamma'$  with  $n - 1$  vertices. We assume that  $\Gamma'$  is connected. Everything that follows in the remaining part of this section can also be formulated for the case where  $\Gamma'$  is not connected, but we will only consider the connected case here for simplicity. We denote by  $\Phi'$  the corresponding root system with simple roots  $\Delta' = \{\alpha_1, \dots, \alpha_{n-1}\}$  and we set  $\Delta'^e = \Delta' \cup \{\alpha_n, \alpha_{n+1}, \dots, \alpha_{m-2}, 0\}$ . We note here that both seeds  $\Sigma^*$  and  $\Sigma_{x_n}^*$  are acyclic. By Lemma 5.25 we then have that

$$\mathcal{A}(\Sigma^*) = \mathbb{Z}[X \cup \{x'_1, \dots, x'_n\}]$$

and that

$$\mathcal{A}(\Sigma_{x_n}^*) = \mathbb{Z}[X^* \cup \{x'_1, \dots, x'_{n-1}\}].$$

We now fix  $p, q \in \{0, 1\}$  and consider the map  $g^{p,q} : -\Delta^e \rightarrow -\Delta'^e$  given by

$$-\alpha_i \mapsto \begin{cases} p(-\alpha_n), & i = m - 1, \\ q(-\alpha_n), & i = m, \\ -\alpha_i, & \text{else,} \end{cases}$$

In what follows, we will adapt the convention that  $x[0] = 0$ . Remaining in agreement with the notation from Theorem 3.29, we also set

$$x[-\alpha_i] = x_i \text{ for every } x_i \in X \setminus \{x_1, \dots, x_n\} \text{ and for every } x_i \in X^* \setminus \{x_1, \dots, x_{n-1}\}. \quad (11)$$

**Theorem 5.39.** *The map  $g^{p,q}$  induces a freezing rooted cluster morphism  $G^{p,q} : \mathcal{A}(\Sigma^*) \rightarrow \mathcal{A}(\Sigma_{x_n}^*)$  via the bijection from Theorem 3.29 and (11) above.*

*Proof.* Let  $x_i \in X$ . Assume first that  $1 \leq i < m - 1$ . Then

$$G^{p,q}(x_i) = G^{p,q}(x[-\alpha_i]) = x[g^{p,q}(-\alpha_i)] = x[-\alpha_i] = x_i = Fr_{x_n}^{p,q}(x_i).$$

Else, if  $i = m - 1$  then

$$G^{p,q}(x_{m-1}) = G^{p,q}(x[-\alpha_{m-1}]) = x[g^{p,q}(-\alpha_{m-1})] = x[p(-\alpha_{m-1})] = px_n = Fr_{x_n}^{p,q}(x_{m-1}).$$

The case where  $i = m$  is dealt with almost identically as the case  $i = m - 1$  and so we skip the details.

We have shown that  $G^{p,q}(x_i) = Fr_{x_n}^{p,q}(x_i)$  for all  $x_i \in X$  and so  $G^{p,q} = Fr_{x_n}^{p,q}$ . The claim then follows by Theorem 5.33.  $\square$

### 5.6.3 Freezing morphisms from triangulations of a convex $n$ -gon

In this section we define inverse systems in the category **fClus** that are built of rooted cluster algebras associated with certain triangulations of convex polygons and freezing morphisms between them. We do this in preparation for Chapter 6, where we define and study certain subrings of the inverse limits (in the category **Ring**) of inverse systems in **fClus**. Of particular importance will be the inverse systems that we will introduce in the remaining part of this section.

Fix  $m, n \in \mathbb{Z}_{\geq 3}$  and let  $(J, \leq)$  be a linearly ordered set such that  $|J| = m$ . Without loss of generality, we can assume that  $J = \{1, \dots, m\}$  and that  $\leq$  is the usual *less or equal to* relation on  $J$ . We let  $\mathcal{P}_m$  be a disk with  $m$  marked points on its boundary that we label cyclically anticlockwise with integers 1 to  $m$  and denote by  $\mathcal{T}_m$  a triangulation of  $\mathcal{P}_m$  with an ear at  $m$ , cf. Remark 5.30. Then  $\Sigma_{\mathcal{T}_m} = (X_{\mathcal{T}_m}, ex_{\mathcal{T}_m}, B^{\mathcal{T}_m})$  is freezeable with  $x_{1m-1} \in ex_{\mathcal{T}_m}$  a freezeable variable and  $\mathcal{A}(\Sigma_{\mathcal{T}_m})$  is acyclic. Letting  $\Sigma^* = \Sigma_{\mathcal{T}_m}$  we then have that  $\Sigma_{x_{1m-1}}^* = \Sigma_{\mathcal{T}_{m-1}} = (X_{\mathcal{T}_{m-1}}, ex_{\mathcal{T}_{m-1}}, B^{\mathcal{T}_{m-1}})$  where  $\mathcal{T}_{m-1}$  is the triangulation of  $\mathcal{P}_{m-1}$  corresponding to the cluster  $X_{\mathcal{T}_m} \setminus \{x_{1m}, x_{m-1m}\}$ . Recall from Section 4.2 that cluster variables in  $\mathcal{A}(\Sigma_{\mathcal{T}_m})$  are identified with the arcs joining two marked points in  $\mathcal{P}_m$  and for any arc  $(i, j)$  of  $(J, \leq)$ , we denote by  $x_{ij}$  the variables corresponding to the arc, also denoted by  $(i, j)$ , joining a marked point labelled with  $i$  to a marked point labelled with  $j$ . The exchangeable variables are the variables corresponding to internal arcs. Now, fix  $p, q \in \{0, 1\}$  and denote

by  $\tilde{f}_{m,m-1}^{p,q} : \mathcal{A}(\Sigma_{\mathcal{T}_m}) \rightarrow \mathcal{A}(\Sigma_{\mathcal{T}_{m-1}})$  the freezing rooted cluster morphism  $\mathcal{A}(\mathcal{T}_m) \rightarrow \mathcal{A}(\mathcal{T}_{m-1})$  which is defined to be the algebraic extension of the map

$$Fr_{x_{1m-1}}^{p,q} = \begin{cases} X_{\mathcal{T}_m} \rightarrow X_{\mathcal{T}_{m-1}} \cup \{0\} \\ x_{ij} \mapsto x_{ij}, \text{ if } 1 \leq i < j < m, \\ x_{mm-1} \mapsto px_{1m-1}, \\ x_{1m} \mapsto qx_{1m-1}. \end{cases}$$

**Proposition 5.40.** *Let  $x_{ij} \neq x_{1m-1}$ ,  $1 \leq i < j < m$ , be a cluster variable in  $\mathcal{A}(\Sigma_{\mathcal{T}_m})$  corresponding to an internal arc of  $\mathcal{P}_m$ . Then  $\tilde{f}_{m,m-1}^{p,q}(x_{ij}) = x_{ij}$ . Moreover,  $\tilde{f}_{m,m-1}^{p,q}(x_{im}) = px_{im-1} + qx_{im-1}$ .*

*Proof.* Consider first an exchangeable variable  $x_{ij} \neq x_{1m-1}$ , such that  $1 \leq i < j < m$ , in some seed mutation equivalent to  $\Sigma_{\mathcal{T}_m}$ . We have that  $x_{ij} = \mu_{x_l} \circ \cdots \circ \mu_{x_1}(x_{kl})$  for some  $x_{kl} \in ex_{\mathcal{T}_m} \setminus \{x_{1m-1}\}$  and where  $(x_1, \dots, x_l)$  is a  $\Sigma_{\mathcal{T}_m}$ -admissible sequence with  $x_s \neq x_{1m-1}$  for all  $1 \leq s \leq l$ . We prove the claim by induction on  $l$ . If  $l = 0$  then  $x_{ij} \in ex_{\mathcal{T}_m} \setminus \{x_{1m-1}\}$  and the claim follows directly from the definition of  $\tilde{f}_{m,m-1}^{p,q}$ . Assume now that the claim holds for all  $\Sigma_{\mathcal{T}_m}$ -admissible sequences  $(x_1, \dots, x_l)$  such that  $x_s \neq x_{1m-1}$  for all  $1 \leq s \leq l$ . Let  $x_{i'j'} \neq x_{1m-1}$  be an exchangeable variable in the seed  $\mu_{x_l} \circ \cdots \circ \mu_{x_1}(\Sigma_{\mathcal{T}_m})$  and let  $x_{ij} \in \mathcal{A}(\Sigma_{\mathcal{T}_m})$  be the cluster variable corresponding to the arc  $(i, j)$  of  $\mathcal{P}_m$  obtained via the diagonal flip (cf. page 16) of the arc  $(i', j')$  in the triangulation corresponding to the cluster of the seed  $\mu_{x_l} \circ \cdots \circ \mu_{x_1}(\Sigma_{\mathcal{T}_m})$ . Then  $1 \leq i < j < m$  and either

$$x_{ij} = \frac{x_{i'i}x_{j'j} + x_{ij'}x_{i'j}}{x_{i'j'}} \quad (12)$$

or

$$x_{ij} = \frac{x_{i'i}x_{jj'} + x_{i'j}x_{ij'}}{x_{i'j'}}. \quad (13)$$

We know from the proof of Theorem 5.33 that for every exchangeable variable  $x \neq x_{1m-1}$  in the seed  $\mu_{x_l} \circ \cdots \circ \mu_{x_1}(\Sigma_{\mathcal{T}_m})$  we have that  $\tilde{f}_{m,m-1}^{p,q}(x) = x$  and that  $x$  is exchangeable in the seed  $\mu_{x_l} \circ \cdots \circ \mu_{x_1}(\Sigma_{\mathcal{T}_{m-1}})$ . Using this, together with (12), (13) and the induction hypothesis, we deduce  $\tilde{f}_{m,m-1}^{p,q}(x_{ij}) = x_{ij}$ , as required.

Next, for any  $1 < i < m - 1$  we have that

$$x_{im} = \frac{x_{1i}x_{m-1m} + x_{1m}x_{im-1}}{x_{1m-1}}.$$

Therefore,

$$\begin{aligned} \tilde{f}_{m,m-1}^{p,q}(x_{im}) &= \tilde{f}_{m,m-1}^{p,q}\left(\frac{x_{1i}x_{m-1m} + x_{1m}x_{im-1}}{x_{1m-1}}\right) \\ &= \frac{px_{1i}x_{1m-1} + qx_{1m-1}x_{im-1}}{x_{1m-1}} \\ &= px_{1i} + qx_{im-1}, \end{aligned}$$

where the last two equalities follow from the definition of  $\tilde{f}_{m,m-1}^{p,q}$  and the first part of this proof.  $\square$

Throughout the rest of this section  $\mathcal{T}_m^f$  denotes a fountain triangulation of  $\mathcal{P}_m$  at the marked point labelled by 1. That is, all of the internal arcs in  $\mathcal{T}_m^f$  originate from 1. See Figure 6 for an example of a fountain triangulation at 1 in a 10-gon. For any  $m \geq 3$ , we

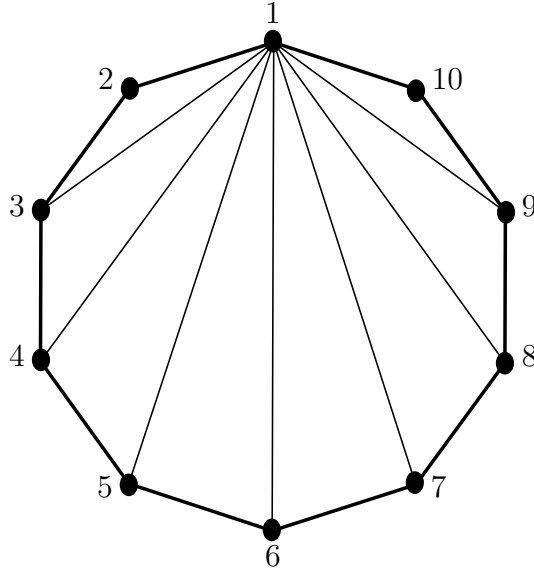

Figure 6: Fountain triangulation of a 10-gon at 1.

denote by  $\mathcal{A}(\mathcal{T}_m^f)$  the cluster algebra rooted at the seed  $\Sigma_{\mathcal{T}_m^f}$ , that is,  $\mathcal{A}(\mathcal{T}_m^f) = (\mathcal{A}(\Sigma_{\mathcal{T}_m^f}), \Sigma_{\mathcal{T}_m^f})$ .

At the end of Chapter 4. (cf. page 54) we defined a parameter-dependent family of ring homomorphisms between cluster algebras associated to convex polygons. We will now consider certain members of that family in more detail.

By Proposition 5.40, for any  $m > 3$ , the freezing rooted cluster morphism  $\tilde{f}_{m,m-1}^{p,q} : \mathcal{A}(\Sigma_{\mathcal{T}_m^f}) \rightarrow \mathcal{A}(\Sigma_{\mathcal{T}_{m-1}^f})$  is the algebraic extension of

$$x_{ij} \mapsto \begin{cases} x_{ij}, & 1 \leq i < j < m \\ qx_{1m-1}, & i = 1, j = m \\ px_{1m-1}, & i = m-1, j = m \\ px_{1i} + qx_{im-1}, & 1 < i < m-1 < j = m. \end{cases}$$

**Corollary 5.41.** *Let  $p, q \in \{0, 1\}$  and  $m > 3$ . Then the ring homomorphism  $\tilde{f}_{m,m-1}^{p,q} : \mathcal{A}(\Sigma_{\mathcal{T}_m^f}) \rightarrow \mathcal{A}(\Sigma_{\mathcal{T}_{m-1}^f})$  yields a freezing rooted cluster morphism  $\mathcal{A}(\mathcal{T}_m^f) \rightarrow \mathcal{A}(\mathcal{T}_{m-1}^f)$ .*

We notice that the definition of the ring homomorphism  $f_{m,m-1}^{p,q} : \mathcal{A}(\Sigma_{\mathcal{T}_m^f}) \rightarrow \mathcal{A}(\Sigma_{\mathcal{T}_{m-1}^f})$  (cf. Definition 4.22) is the same as that of  $\tilde{f}_{m,m-1}^{p,q} : \mathcal{A}(\Sigma_{\mathcal{T}_m^f}) \rightarrow \mathcal{A}(\Sigma_{\mathcal{T}_{m-1}^f})$ . For the notational simplicity, we will use  $f_{m,m-1}^{p,q}$  instead of  $\tilde{f}_{m,m-1}^{p,q}$  throughout the rest of this chapter.

**Remark 5.42.** It is worth considering how the maps  $f_{m,m-1}^{0,1}$  and  $f_{m,m-1}^{1,0}$  act on an arbitrary triangulation  $\mathcal{T}_m$  of  $\mathcal{P}_m$ . Denote a triangle in  $\mathcal{T}_m$  by a triple  $(i, j, k)$ ,  $1 \leq i < j < k \leq m$ , of the end points of the edges of that triangle. Let us first consider a concrete example. Let  $\mathcal{T}_7$  be the following triangulation of  $\mathcal{P}_7$ :

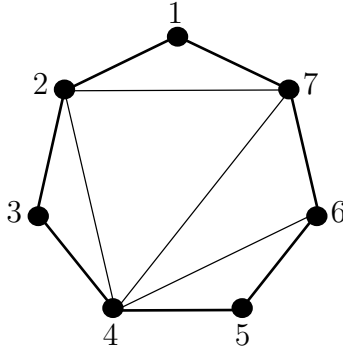

The corresponding cluster is the set

$$X_{\mathcal{T}_7} = \{x_{12}, x_{23}, x_{34}, x_{45}, x_{56}, x_{67}, x_{17}, x_{24}, x_{27}, x_{46}, x_{47}\}.$$

Now,

$$f_{7,6}^{0,1}(X_{\mathcal{T}_7}) = \{x_{12}, x_{23}, x_{34}, x_{45}, x_{56}, x_{16}, x_{24}, x_{26}, x_{46}, 0\}$$

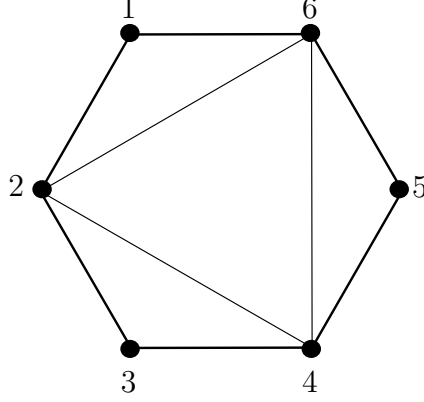

and we observe that  $f_{7,6}^{0,1}(X_{\mathcal{T}_7}) \setminus \{0\}$  is in fact a cluster, with the corresponding triangulation of  $\mathcal{P}_6$ . Geometrically speaking, the triangulation corresponding to  $f_{7,6}^{0,1}(X_{\mathcal{T}_7}) \setminus \{0\}$  is obtained from  $\mathcal{T}_7$  by *collapsing* the triangle  $(4, 6, 7)$  to the arc connecting  $(4, 6)$ , by *collapsing* the arc  $(6, 7)$ . More generally, the map  $f_{m,m-1}^{0,1}$  preserves (modulo relabelling of the marked point  $m$  to  $m-1$ ) a triangle  $(i, j, k)$  of  $\mathcal{T}_m$  if  $j \neq m-1$  and *collapses* the triangle  $(i, m-1, m)$  to the arc  $(i, m-1)$ , by *collapsing* the arc  $(m-1, m)$ . Similarly, the map  $f_{m,m-1}^{1,0}$  preserves (again, modulo relabelling) a triangle  $(i, j, k)$  of  $\mathcal{T}_m$  if  $i \neq 1$  and  $k \neq m$  and *collapses* a triangle  $(1, j, m)$  to the arc  $(1, j)$ , by *collapsing* the arc  $(1, m)$ . Thus, we often say that the maps  $f_{m,m-1}^{0,1}$  and  $f_{m,m-1}^{1,0}$  correspond to *collapsing a triangle*.

**Corollary 5.43.** *Let  $m > n \geq 3$  and let  $p, q \in \{0, 1\}$  be such that  $pq = 0$ . The map  $f_{m,n}^{p,q} : \mathcal{A}(\Sigma_{\mathcal{T}_m^f}) \rightarrow \mathcal{A}(\Sigma_{\mathcal{T}_n^f})$  defined as the algebraic extension of*

$$x_{ij} \mapsto \begin{cases} x_{ij}, & 1 \leq i < j \leq n \\ px_{1i} + qx_{in}, & 1 \leq i \leq n < j \leq m \\ 0, & n < i < j \leq m, \end{cases}$$

where by abuse of notation  $x_{ii} = 0$  for all  $1 \leq i \leq m$ , yields a freezing rooted cluster morphism  $\mathcal{A}(\mathcal{T}_m^f) \rightarrow \mathcal{A}(\mathcal{T}_n^f)$ .

*Proof.* Let  $x_{ij} \in \mathcal{A}(\mathcal{T}_m^f)$  be a cluster variable, for some  $1 \leq i < j \leq m$ . We claim that  $f_{m,n}^{p,q}(x_{ij}) = f_{n+1,n}^{p,q} \circ \dots \circ f_{m,m-1}^{p,q}(x_{ij})$ . The cases where  $1 \leq i < j \leq n$  or where  $n < i < j \leq m$

are straightforward. Consider now the case where  $i = 1 < n < j \leq m$ . We have that

$$\begin{aligned}
f_{n+1,n}^{p,q} \circ \cdots \circ f_{m,m-1}^{p,q}(x_{1j}) &= f_{n+1,n}^{p,q} \circ \cdots \circ f_{j,j-1}^{p,q}(x_{1j}) \\
&= f_{n+1,n}^{p,q} \circ \cdots \circ f_{j-1,j-2}^{p,q}(qx_{1j-1}) \\
&= \dots \\
&= f_{n+1,n}^{p,q}(q^{j-(n+1)}x_{1n+1}) \\
&= q^{j-n}x_{1n} = qx_{1n} = px_{11} + qx_{1n} = f_{m,n}^{p,q}(x_{1j}).
\end{aligned}$$

The only remaining case to consider is where  $1 < i \leq n < j \leq m$ . We have

$$\begin{aligned}
f_{n+1,n}^{p,q} \circ \cdots \circ f_{m,m-1}^{p,q}(x_{ij}) &= f_{n+1,n}^{p,q} \circ \cdots \circ f_{j,j-1}^{p,q}(x_{ij}) \\
&= f_{n+1,n}^{p,q} \circ \cdots \circ f_{j-1,j-2}^{p,q}(px_{1i} + qx_{ij-1}) \\
&= px_{1i} + f_{n+1,n}^{p,q} \circ \cdots \circ f_{j-2,j-3}^{p,q}(q(px_{1i} + qx_{ij-2})) \\
&= px_{1i} + f_{n+1,n}^{p,q} \circ \cdots \circ f_{j-2,j-3}^{p,q}(q^2x_{ij-2}) \\
&= \dots \\
&= px_{1i} + f_{n+1,n}^{p,q}(q^{j-(n+1)}x_{in+1}) \\
&= \begin{cases} px_{1n} + q^{j-(n+1)}px_{1n}, & \text{if } i = n, \\ px_{1i} + q^{j-n}x_{in}, & \text{if } 1 < i < n \end{cases} \\
&= px_{1i} + qx_{in} = f_{m,n}^{p,q}(x_{ij}).
\end{aligned}$$

Now as  $f_{m,n}^{p,q}$  is equal to the composition of freezing rooted cluster morphisms, by Corollary 5.41, it is a freezing rooted cluster morphism itself.  $\square$

An analogous statement for the case where  $p = q = 1$  is as follows.

**Corollary 5.44.** *Let  $m > n \geq 3$  and let  $p = q = 1$ . The map  $f_{m,n}^{1,1} : \mathcal{A}(\Sigma_{\mathcal{T}_m^f}) \rightarrow \mathcal{A}(\Sigma_{\mathcal{T}_n^f})$  defined as the algebraic extension of*

$$x_{ij} \mapsto \begin{cases} x_{ij}, & 1 \leq i < j \leq n \\ (j-n)x_{1i} + x_{in}, & 1 \leq i < n < j \leq m \\ (j-i)x_{1n}, & n \leq i < j \leq m, \end{cases}$$



where by abuse of notation  $x_{ii} = 0$  for all  $1 \leq i \leq m$ , yields a freezing rooted cluster morphism  $\mathcal{A}(\mathcal{T}_m^f) \rightarrow \mathcal{A}(\mathcal{T}_n^f)$ .

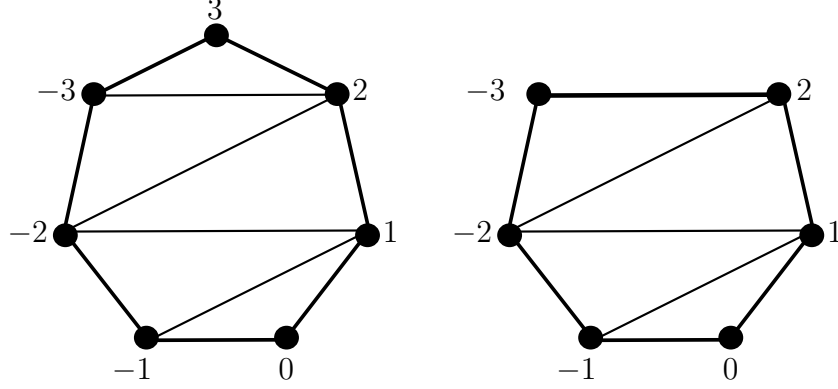

Figure 7: Zig-zag triangulations  $\mathcal{T}_7^{zz}$  and  $\mathcal{T}_6^{zz}$  of  $\mathcal{P}_7$  and  $\mathcal{P}_6$ , respectively.

*Proof.* Consider a cluster variable  $x_{ij}$  of  $\mathcal{A}(\mathcal{T}_m^f)$ , for some  $1 \leq i < j \leq m$ . We will show that  $f_{m,n}^{1,1}(x_{ij}) = f_{n+1,n}^{1,1} \circ \dots \circ f_{m,m-1}^{1,1}(x_{ij})$ . The case where  $1 \leq i < j \leq n$  is straightforward. Consider now the case where  $1 \leq i < n < j \leq m$ . We have that

$$\begin{aligned}
f_{n+1,n}^{1,1} \circ \dots \circ f_{m,m-1}^{1,1}(x_{ij}) &= f_{n+1,n}^{1,1} \circ \dots \circ f_{j,j-1}^{1,1}(x_{ij}) \\
&= f_{n+1,n}^{1,1} \circ \dots \circ f_{j-1,j-2}^{1,1}(x_{1i} + x_{ij-1}) \\
&= x_{1i} + f_{n+1,n}^{1,1} \circ \dots \circ f_{j-2,j-3}^{1,1}(x_{1i} + x_{ij-2}) \\
&= \dots \\
&= (j - (n + 1))x_{1i} + f_{n+1,n}^{1,1}(x_{in+1}) \\
&= \begin{cases} x_{1n}, & i = 1, \\ (j - n)x_{1i} + x_{in}, & 1 < i < n \end{cases} \\
&= f_{m,n}^{1,1}(x_{ij}).
\end{aligned}$$

Finally, if  $x_{ij}$  is such that  $n \leq i < j \leq m$  then we have that

$$\begin{aligned}
f_{n+1,n}^{1,1} \circ \cdots \circ f_{m,m-1}^{1,1}(x_{ij}) &= f_{n+1,n}^{1,1} \circ \cdots \circ f_{j,j-1}^{1,1}(x_{ij}) \\
&= f_{n+1,n}^{1,1} \circ \cdots \circ f_{j-1,j-2}^{1,1}(x_{1i} + x_{ij-1}) \\
&= \dots \\
&= f_{n+1,n}^{1,1} \circ \cdots \circ f_{i+1,i}^{1,1}((j - (i + 1))x_{1i} + x_{i+1i}) \\
&= f_{n+1,n}^{1,1} \circ \cdots \circ f_{i,i-1}^{1,1}((j - i)x_{1i}) = (j - i)x_{1i}.
\end{aligned}$$

Now since  $f_{m,n}^{1,1}$  is equal to the composition of freezing rooted cluster morphisms, it follows it is too a freezing rooted cluster morphism, as required.  $\square$

A canonical example of an inverse system in **fClus** is then given by the pair  $(\mathcal{A}(\mathcal{T}_m^f), f_{m,n}^{p,q})$ , for a fixed  $p, q \in \{0, 1\}$ .

In the remaining part of this chapter  $\lfloor - \rfloor$  and  $\lceil - \rceil$  denote the usual floor and ceiling functions, respectively. We will now let  $J = \{m^-, m^- + 1, \dots, m^+ - 1, m^+\}$  be the set of  $m$  consecutive integers from  $m^- := \lfloor \frac{m}{2} \rfloor$  to  $m^+ := \lfloor \frac{m-1}{2} \rfloor$ . By equipping  $J$  with the usual *less or equal to* relation, denoted by  $\leq$ , we obtain a linearly ordered set  $(J, \leq)$  and for any  $m \geq 3$  we label the marked points of  $\mathcal{P}_m$  cyclically anticlockwise with the integers from  $(J, \leq)$  this time. We also introduce certain *relabelling* maps. Namely, we define  $h_m : J \rightarrow \{1, \dots, m\}$  to be the bijection that maps  $i$  to  $i + \lfloor \frac{m+1}{2} \rfloor$  and  $k_m : J \rightarrow \{1, \dots, m\}$  to be the bijection given by

$$i \mapsto \begin{cases} m, & i = m^- \text{ and } m \text{ is even,} \\ i + \lfloor \frac{m}{2} \rfloor, & \text{else.} \end{cases}$$

We will denote by  $h_m^{-1}$  and by  $k_m^{-1}$  the inverse functions of  $h_m$  and  $k_m$ , respectively. Now, for any  $m \geq 3$  we consider the so-called *zig-zag* triangulation  $T_m^{zz}$  of  $\mathcal{P}_m$  that corresponds to the following triangulation of  $(J, \leq)$ :

$$\{(i, -i) : m^- < i \leq -1\} \cup \{(-(i+1), i) : 1 \leq i < m^+\} \cup \{(i, i+1) : m^- \leq i < m^+\} \cup \{(m^-, m^+)\}.$$

See Figure 7 for an example of a zig-zag triangulation of  $\mathcal{P}_7$  and  $\mathcal{P}_6$ . Moreover, if  $T_m$  is a triangulation of  $\mathcal{P}_m$  (with the above labelling) then we denote by  $h_m(T_m)$  the triangulation

of  $\mathcal{P}_m$ , where the marked points of  $\mathcal{P}_m$  are labelled cyclically anticlockwise with integers 1 to  $m$ . That is,

$$h(T_m) = \{(h_m(i), h_m(j)) \mid (i, j) \in T_m\}.$$

We will use the same notation for the relabelling maps  $k_m$ ,  $h_m^{1-}$  and  $k_m^{-1}$ . See Figure 8 for an example of  $h_7(\mathcal{T}_7^{zz})$  and of  $h_6(\mathcal{T}_6^{zz})$ .

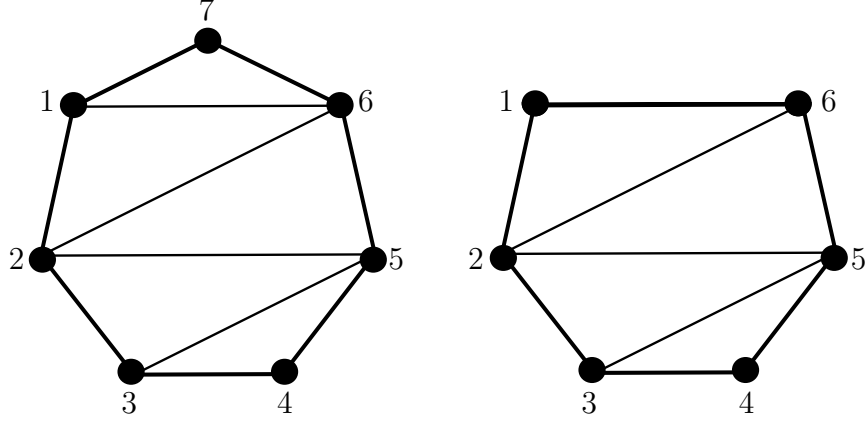

Figure 8: Zig-zag triangulations  $h_7(\mathcal{T}_7^{zz})$  and  $h_6(\mathcal{T}_6^{zz})$  of  $\mathcal{P}_7$  and  $\mathcal{P}_6$ , respectively.

Now we aim to construct an inverse system in **fClus**, which has the rooted cluster algebras  $\mathcal{A}(\mathcal{T}_m^{zz})$  as its objects. We note that if  $m$  is odd then  $\mathcal{T}_m^{zz}$  has an ear at  $m^+$ , whereas if  $m$  is even then  $\mathcal{T}_m^{zz}$  has an ear at  $m^-$ . Let us now consider the maps  $\tilde{f}_{m,n} : \mathcal{A}(\Sigma_{\mathcal{T}_m^{zz}}) \rightarrow \mathcal{A}(\Sigma_{\mathcal{T}_n^{zz}})$  and  $\tilde{g}_{m,n} : \mathcal{A}(\Sigma_{\mathcal{T}_m^{zz}}) \rightarrow \mathcal{A}(\Sigma_{\mathcal{T}_n^{zz}})$  defined by the algebraic extension of

$$x_{ij} \mapsto \begin{cases} x_{ij}, & n^- \leq i < j \leq n^+, \\ x_{in^+}, & n^- \leq i < n^+ < j \leq m^+, \\ x_{jn^+}, & m^- \leq i < n^- \leq j < n^+, \\ 0, & \text{else} \end{cases} \quad \text{and of } x_{ij} \mapsto \begin{cases} x_{ij}, & n^- \leq i < j \leq n^+, \\ x_{n^-i}, & n^- < i \leq n^+ < j \leq m^+, \\ x_{n^-j}, & m^- \leq i < n^- < j \leq n^+, \\ 0, & \text{else,} \end{cases}$$

respectively.

**Proposition 5.45.** *The maps  $\tilde{f}_{m,n} : \mathcal{A}(\Sigma_{\mathcal{T}_m^{zz}}) \rightarrow \mathcal{A}(\Sigma_{\mathcal{T}_n^{zz}})$  and  $\tilde{g}_{m,n} : \mathcal{A}(\Sigma_{\mathcal{T}_m^{zz}}) \rightarrow \mathcal{A}(\Sigma_{\mathcal{T}_n^{zz}})$  yield freezing rooted cluster morphisms  $\mathcal{A}(\mathcal{T}_m^{zz}) \rightarrow \mathcal{A}(\mathcal{T}_n^{zz})$ .*

*Proof.* Let  $\Sigma$  be a seed and let  $\underline{x} = (x_1, \dots, x_l)$  be a  $\Sigma$ -admissible sequence. We set  $\mu_{\underline{x}}(\Sigma) := \mu_{x_l} \circ \dots \circ \mu_{x_1}(\Sigma)$ .

Assume that  $m > 3$  is odd. Let  $l = \lceil \frac{m}{2} \rceil$  and set

$$\underline{x}_m = \begin{cases} (x_{13}), & m = 5 \\ (x_{1m-2}, x_{13}, \dots, x_{l+2}, x_{l-2}, x_{l+1}, x_{l-1}, x_l), & m > 5, \end{cases}$$

a  $(f_{m,m-1}^{0,1}, \Sigma_{\mathcal{T}_m^f}, \Sigma_{\mathcal{T}_{m-1}^f})$ -biadmissible sequence for every (odd)  $m > 3$ . We notice that  $\Sigma_{h_n(\mathcal{T}_n^{zz})} = \mu_{\underline{x}_n}(\Sigma_{\mathcal{T}_n^f})$  when  $n$  is odd and that  $\Sigma_{h_n(\mathcal{T}_n^{zz})} = \mu_{f_{n+1,n}^{0,1}(\underline{x}_{n+1})}(\Sigma_{\mathcal{T}_n^f})$  when  $n$  is even. Moreover, we have that  $f_{m,m-1}^{0,1} : \mathcal{A}(\Sigma_{h_m(\mathcal{T}_m^{zz})}) \rightarrow \mathcal{A}(\Sigma_{h_{m-1}(\mathcal{T}_{m-1}^{zz})})$  yields a freezing rooted cluster morphism by Proposition 5.4. Now we have that  $\tilde{f}_{m,m-1} = H_{m-1}^{-1} \circ f_{m,m-1}^{0,1} \circ H_m$ , where  $H_m : \mathcal{A}(\Sigma_{\mathcal{T}_m^{zz}}) \rightarrow \mathcal{A}(\Sigma_{h_m(\mathcal{T}_m^{zz})})$  and  $H_{m-1}^{-1} : \mathcal{A}(\Sigma_{h_{m-1}(\mathcal{T}_{m-1}^{zz})}) \rightarrow \mathcal{A}(\Sigma_{\mathcal{T}_{m-1}^{zz}})$  are the canonical ring isomorphisms induced by the maps  $h_m$  and  $h_{m-1}^{-1}$ , respectively, both inducing freezing rooted cluster morphisms. Thus,  $\tilde{f}_{m,m-1}$  is equal to the composition of rooted freezing cluster morphisms and so it is a freezing rooted cluster morphism itself.

Next we assume that  $m > 4$  is even. Let  $l = \frac{m}{2}$  and set

$$\underline{x}_m = \begin{cases} (x_{13}), & m = 6 \\ (x_{1m-3}, x_{13}, \dots, x_{l+2}, x_{l-2}, x_{l+1}, x_{l-1}, x_l), & m > 6, \end{cases}$$

a  $(f_{m,m-1}^{0,1}, \Sigma_{\mathcal{T}_m^f}, \Sigma_{\mathcal{T}_{m-1}^f})$ -biadmissible sequence for every (even)  $m > 4$ . If  $m = 4$  then  $\underline{x}_4$  is assumed to be an empty sequence. Again we notice that  $\Sigma_{k_n(\mathcal{T}_n^{zz})} = \mu_{\underline{x}_n}(\Sigma_{\mathcal{T}_n^f})$  when  $n$  is even and that  $\Sigma_{k_n(\mathcal{T}_n^{zz})} = \mu_{f_{n+1,n}^{0,1}(\underline{x}_{n+1})}(\Sigma_{\mathcal{T}_n^f})$  when  $n$  is odd. Moreover, we have that  $f_{m,m-1}^{0,1} : \mathcal{A}(k_m(\mathcal{T}_m^{zz})) \rightarrow \mathcal{A}(k_{m-1}(\mathcal{T}_{m-1}^{zz}))$  is a freezing rooted cluster morphism by Proposition 5.4. Next we have that  $\tilde{f}_{m,m-1} = K_{m-1}^{-1} \circ f_{m,m-1}^{0,1} \circ K_m$ , where  $K_m : \mathcal{A}(\Sigma_{\mathcal{T}_m^{zz}}) \rightarrow \mathcal{A}(\Sigma_{k_m(\mathcal{T}_m^{zz})})$  and  $K_{m-1}^{-1} : \mathcal{A}(\Sigma_{k_{m-1}(\mathcal{T}_{m-1}^{zz})}) \rightarrow \mathcal{A}(\Sigma_{\mathcal{T}_{m-1}^{zz}})$  are the canonical ring isomorphisms induced by the maps  $k_m$  and  $k_{m-1}^{-1}$ , respectively, that themselves induce freezing rooted cluster morphisms. Thus,  $\tilde{f}_{m,m-1}$  is equal to the composition of rooted freezing cluster morphisms and so it is a freezing rooted cluster morphism itself.

Next we show that  $\tilde{f}_{m,n} = \tilde{f}_{n+1,n} \circ \dots \circ \tilde{f}_{m,m-1}$ . Let  $x_{ij} \in \mathcal{A}(\Sigma_{\mathcal{T}_m^{zz}})$ . Assume first that  $n^- \leq i < n^+ < j \leq m^+$ . Then immediately we have that

$$\tilde{f}_{n+1,n} \circ \dots \circ \tilde{f}_{m,m-1}(x_{ij}) = \tilde{f}_{n+1,n} \circ \dots \circ \tilde{f}_{j',j'-1}(x_{ij}),$$

where  $j'$  is such that  $j'^+ = j$ . But then

$$\begin{aligned} \tilde{f}_{n+1,n} \circ \cdots \circ \tilde{f}_{j',j'-1}(x_{ij}) &= \tilde{f}_{n+1,n} \circ \cdots \circ \tilde{f}_{j'-1,j'-2}(x_{i(j'-1)^+}) = \cdots = \tilde{f}_{n+1,n}(x_{i(n+1)^+}) = x_{in^+} \\ &= \tilde{f}_{m,n}(x_{ij}). \end{aligned}$$

Next we assume that  $m^- \leq i < n^- \leq j < n^+$ . Then

$$\tilde{f}_{n+1,n} \circ \cdots \circ \tilde{f}_{m,m-1}(x_{ij}) = \tilde{f}_{n+1,n} \circ \cdots \circ \tilde{f}_{i',i'-1}(x_{ij}),$$

where  $i'$  is such that  $i'^- = i$ . But then

$$\begin{aligned} \tilde{f}_{n+1,n} \circ \cdots \circ \tilde{f}_{i',i'-1}(x_{ij}) &= \tilde{f}_{n+1,n} \circ \cdots \circ \tilde{f}_{i'-1,i'-2}(x_{j(i'-1)^+}) = \tilde{f}_{i'-1,n}(x_{j(i'-1)^+}) = x_{jn^+} \\ &= \tilde{f}_{m,n}(x_{ij}), \end{aligned}$$

where the second equality follows from the previous paragraph. The remaining cases are straightforward and so we skip the details. Finally, since  $\tilde{f}_{m,n} = \tilde{f}_{n+1,n} \circ \cdots \circ \tilde{f}_{m,m-1}$  and  $\tilde{f}_{m,m-1}$  is a freezing rooted cluster morphism for every  $m > 3$ , it follows that  $\tilde{f}_{m,n}$  is a freezing rooted cluster morphism.

Now to show that  $\tilde{g}_{m,m-1}$  is a freezing rooted cluster morphism one uses the same argument as that used above for  $\tilde{f}_{m,m-1}$  with  $f_{m,m-1}^{0,1}$  being replaced by  $f_{m,m-1}^{1,0}$ . The calculations needed to show that  $\tilde{g}_{m,n} = \tilde{g}_{n+1,n} \circ \cdots \circ \tilde{g}_{m,m-1}$  are very similar to those that were carried out in order to show that  $\tilde{f}_{m,n} = \tilde{f}_{n+1,n} \circ \cdots \circ \tilde{f}_{m,m-1}$  and so we leave the details of those out for brevity. Finally we deduce that  $\tilde{g}_{m,n}$  induces a freezing rooted cluster morphism and we are done.  $\square$

Immediately, we get two obvious choices for inverse systems in **fClus**, namely,  $(\mathcal{A}(\mathcal{T}_m^{zz}), \tilde{f}_{m,n})$  and  $(\mathcal{A}(\mathcal{T}_m^{zz}), \tilde{g}_{m,n})$ .

**Remark 5.46.** The geometric interpretation of  $\tilde{f}_{m,m-1}$  and  $\tilde{g}_{m,m-1}$  is the same, up to re-belling of marked points, as that of maps  $f_{m,m-1}^{0,1}$  and  $f_{m,m-1}^{1,0}$ , respectively, which we discussed in detail in Remark 5.42.

We will see in Chapter 6 that rooting our cluster algebras at seeds coming from different triangulations, will give rise to different (i.e. non-isomorphic as rings) so-called *pro-cluster algebras*, which we will formally define in Chapter 6.

Having constructed two distinct freezing morphism between cluster algebras rooted at the same triangulations, we can now construct (infinitely) many inverse systems in the category **fClus** besides the two canonical ones, the already mentioned  $(\mathcal{A}(\mathcal{T}_m^{zz}), \tilde{f}_{m,n})$  and  $(\mathcal{A}(\mathcal{T}_m^{zz}), \tilde{g}_{m,n})$ . Before we move onto to the last chapter, let us first consider an example of this.

**Example 5.47.** Consider the inverse system  $(\mathcal{A}(\mathcal{T}_m^{zz}), z_{m,n})$ , where  $z_{m,n} = z_{n+1,n} \circ \cdots \circ z_{m,m-1}$  and where

$$z_{k,k-1} = \begin{cases} \tilde{g}_{k,k-1}, & \text{if } k \text{ is even,} \\ \tilde{f}_{k,k-1}, & \text{if } k \text{ is odd,} \end{cases}$$

for all  $3 \leq n < k \leq m$ . Explicitly, the map  $z_{m,n} : \mathcal{A}(\mathcal{T}_m^{zz}) \rightarrow \mathcal{A}(\mathcal{T}_n^{zz})$  is given by the algebraic extension of

$$x_{ij} \mapsto \begin{cases} x_{ij}, & n^- \leq i < j \leq n^+ \\ x_{in^+}, & n^- \leq i < n^+ \leq j \leq m^+ \\ x_{n^-j}, & m^- \leq i \leq n^- < j \leq n^+ \\ x_{n^-n^+}, & m^- \leq i \leq n^- < n^+ \leq j \leq m^+ \\ 0, & m^- \leq i < j \leq n^- \text{ or } n^+ \leq i < j \leq m^+. \end{cases}$$

To convince ourselves that this is indeed the case, we first observe that if  $k$  is even then  $(k-1)^- = k^- + 1$  and  $(k-1)^+ = k^+$  and that

$$\begin{aligned} z_{k,k-1}(x_{ij}) &= \begin{cases} x_{ij}, & k^- + 1 \leq i < j \leq k^+ \\ x_{k^-+1j}, & k^- = i < k^- + 1 < j \leq k^+ \\ 0, & i = k^-, j = k^- + 1. \end{cases} \\ &= \tilde{g}_{k,k-1}(x_{ij}). \end{aligned}$$

Similarly, if  $k$  is odd then we have that  $(k-1)^- = k^-$  and  $(k-1)^+ = k^+ - 1$  and then that

$$\begin{aligned} z_{k,k-1}(x_{ij}) &= \begin{cases} x_{ij}, & k^- \leq i < j \leq k^+ - 1 \\ x_{ik^+-1}, & k^- \leq i < k^+ - 1 < j = k^+ \\ 0, & i = k^+ - 1, j = k^+. \end{cases} \\ &= \tilde{f}_{k,k-1}(x_{ij}), \end{aligned}$$

as required.

## 6 Pro-clusters and pro-cluster algebras

This chapter will introduce a way of constructing a special family of algebras (with cluster-like combinatorics) from inverse systems in **fClus**. Informally speaking, given an inverse system in **fClus** and its corresponding limit in the category of rings, we lift clusters from the cluster algebras in a given inverse system back to the inverse limit and use the resulting subset of elements to generate our algebra, the so-called *pro-cluster algebra*.

As it turns out, in some cases the *pro-cluster algebras* are equal as rings to cluster algebras and they can be seen as a cluster algebraic counterpart of certain categories, something we will explain in more detail in the relevant Sections 6.4 and 6.5.

As far as the concrete examples go, we will consider here the pro-cluster algebras arising from inverse systems coming from convex polygons and freezing morphisms, building upon the results established in Section 5.6.3.

### 6.1 Definition of a pro-cluster and a pro-cluster algebra

Fix  $m, n, i, j \in \mathbb{Z}$ . Let  $\{\Sigma_m = (X_m, ex_m, B_m) \mid m \geq 0\}$  be a family of seeds and let  $S = (\mathcal{A}(\Sigma_m), \varphi_{m,n} : \mathcal{A}(\Sigma_m) \rightarrow \mathcal{A}(\Sigma_n))_{m \geq n \geq 0}$  be an inverse system in **fClus** with  $(R, (\varphi_m)_{m \geq 0})$  its limit in the category **Ring** of rings.

**Remark 6.1.** More generally, the family  $\{\Sigma_m\}$  of seeds can be indexed by any directed set and the following definitions can be adjusted naturally to account for that. Thus, we will often use a different indexing set in place of  $\mathbb{Z}_{\geq 0}$  without further comment. For example, in the following sections we work with the inverse systems of cluster algebras associated with convex  $m$ -gons and the corresponding family of seeds is defined over the set  $\mathbb{Z}_{\geq 3}$  rather than  $\mathbb{Z}_{\geq 0}$ .

**Definition 6.2.** A sequence  $\underline{X} = (X_i)_{i \geq 0}$  of subsets of  $\mathcal{A}(\Sigma_i)$  is said to be  $S$ -admissible if there exists  $l_{\underline{X}} \geq 0$  such that for all  $m \geq n \geq l_{\underline{X}}$ :

- $X_m$  is a cluster in  $\mathcal{A}(\Sigma_m)$ ,
- $\varphi_{m,n}(X_m) \subseteq X_n \cup \mathbb{Z}$ .



We call an  $S$ -admissible sequence  $\underline{X}$   $S$ -complete (or simply *complete*, if clear from context) if  $l_{\underline{X}} = 0$ . The *pro-cluster* associated to  $(X_m)_{m \geq l_{\underline{X}}}$  is the set

$$X(\underline{X}) := \bigcap_{m \geq l_{\underline{X}}} (\varphi_m^{-1}(X_m \cup \mathbb{Z}) \setminus \mathbb{Z}) \subset R.$$

We give many examples of admissible sequences and their corresponding pro-clusters later in this chapter: see Examples 6.14, 6.22, 6.28, 6.29, 6.37, 6.41 and 6.50. Before we move forward, let us first justify that the notation introduced in the above definition does not depend on the choice of  $l_{\underline{X}}$  and so every  $S$ -admissible sequence gives rise to precisely one pro-cluster. This is the direct consequence of the following lemma.

**Lemma 6.3.** *Let  $\underline{X} = (X_i)_{i \geq 0}$  be  $S$ -admissible and let  $k \in \mathbb{Z}_{>0}$  be such that  $k > l_{\underline{X}}$ . Then*

$$X(\underline{X}) = \bigcap_{m \geq k} (\varphi_m^{-1}(X_m \cup \mathbb{Z}) \setminus \mathbb{Z}).$$

*Proof.* Set  $X' := \bigcap_{m \geq k} (\varphi_m^{-1}(X_m \cup \mathbb{Z}) \setminus \mathbb{Z})$ . First, let  $x \in X(\underline{X})$ . Then  $\varphi_m(x) \in X_m \cup \mathbb{Z}$  for all  $m \geq l_{\underline{X}}$  and since  $k > l_{\underline{X}}$  we have that  $\varphi_m(x) \in X_m \cup \mathbb{Z}$  for all  $m \geq k$  and so  $x \in X'$ .

Now, let  $x' \in X'$ . Let  $n \geq l_{\underline{X}}$  be such that  $n < k$ . We must show that  $\varphi_n(x') \in X_n \cup \mathbb{Z}$ . Let  $m \in \mathbb{Z}_{>0}$  be such that  $m \geq k > n \geq l_{\underline{X}}$ . Then  $\varphi_n(x') = \varphi_{m,n}(\varphi_m(x'))$ , since  $x' \in X'$ . Now, if  $\varphi_m(x') \in \mathbb{Z}$  then  $\varphi_n(x') = \varphi_{m,n}(\varphi_m(x')) \in \mathbb{Z}$ . Else, if  $\varphi_m(x') \in X_m$  then since  $\varphi_{m,n}(X_m) \subseteq X_n \cup \mathbb{Z}$ , it follows that  $\varphi_n(x') = \varphi_{m,n}(\varphi_m(x')) \subseteq X_n \cup \mathbb{Z}$ , as required.  $\square$

**Corollary 6.4.** *Let  $\underline{X}$  be  $S$ -admissible. Then there is precisely one pro-cluster arising from  $\underline{X}$ , in the way described in Definition 6.2.*

**Remark 6.5.** Given a  $S$ -admissible sequence  $\underline{X} = (X_i)_{i \geq 0}$ , we can easily construct from it, in a trivial way, another  $S$ -admissible sequence that yields the same pro-cluster. Let  $\underline{Y} = (Y_i)_{i \geq 0}$  be such that  $Y_i = X_i$  for all  $i > l_{\underline{X}}$  and such that  $Y_i$  is an arbitrary subset of  $\mathcal{A}(\Sigma_i)$ , allowing  $Y_i \neq X_i$  for all  $0 \leq i \leq l_{\underline{X}}$ . Then  $\underline{Y}$  is  $S$ -admissible and  $X(\underline{X}) = X(\underline{Y})$ .

Consider now the set  $\underline{X}_S := \{\underline{X} \mid \underline{X} \text{ is } S\text{-admissible}\}$  of all  $S$ -admissible sequences and denote by  $\mathcal{X}(\underline{X}_S)$  the set of all pro-clusters coming from  $\underline{X}_S$ . That is,

$$\mathcal{X}(\underline{X}_S) := \{X(\underline{X}) \mid \underline{X} \in \underline{X}_S\}.$$

Finally, we have:

**Definition 6.6.** The *pro-cluster algebra associated with  $S$* , denoted  $\mathcal{A}(S)$ , is the subring of  $R$  generated by all the elements of all the pro-clusters in  $\mathcal{X}(\underline{X}_S)$ .

We end this section by showing, that if the map  $\varphi_{m,n} : \mathcal{A}(\Sigma_m) \rightarrow \mathcal{A}(\Sigma_n)$  in the inverse system  $S$  always maps clusters to clusters, then it is enough to only consider  $S$ -complete admissible sequences.

**Proposition 6.7.** *Let  $S = (\mathcal{A}(\Sigma_m), \varphi_{m,n} : \mathcal{A}(\Sigma_m) \rightarrow \mathcal{A}(\Sigma_n))_{m \geq n \geq 0}$  be an inverse system in  $\mathbf{fClus}$ . Let  $X_m$  be a cluster of  $\mathcal{A}(\Sigma_m)$  and assume that  $\varphi_{m,n}(X_m) \setminus \mathbb{Z}$  is a cluster in  $\mathcal{A}(\Sigma_n)$  for all  $m \geq n \geq 0$ . Then*

$$\mathcal{X}(\underline{X}_S) = \{X(\underline{X}) \mid \underline{X} \in \underline{X}_S \text{ is } S\text{-complete}\}.$$

*Proof.* Let  $\underline{X}$  be  $S$ -complete. By definition,  $\underline{X}$  is  $S$ -admissible and so  $\underline{X} \in \underline{X}_S$ . Thus  $X(\underline{X}) \in \mathcal{X}(\underline{X}_S)$  and so  $\{X(\underline{X}) \mid \underline{X} \in \underline{X}_S \text{ is } S\text{-complete}\} \subseteq \mathcal{X}(\underline{X}_S)$ .

Let  $\underline{X} = (X_i)_{i \geq 0}$  be a  $S$ -admissible sequence such that  $l_{\underline{X}} > 0$ . Let  $\underline{Y} = (Y_i)_{i \geq 0}$  be such that  $Y_i = X_i$  for all  $i \geq l_{\underline{X}}$  and such that  $Y_i = \varphi_{l_{\underline{X}},i}(X_i) \setminus \mathbb{Z}$  for all  $0 \leq i < l_{\underline{X}}$ . By assumption we have that  $Y_i$  is a cluster in  $\mathcal{A}(\Sigma_i)$  for all  $0 \leq i < l_{\underline{X}}$ . First, we want to show that  $\varphi_{m,n}(Y_m) \subseteq Y_n \cup \mathbb{Z}$  for all  $m \geq n \geq 0$ , i.e. that  $\underline{Y}$  is  $S$ -complete.

Let  $0 \leq n < m < l_{\underline{X}}$ . Then

$$\varphi_{m,n}(Y_m) \subseteq \varphi_{m,n}(\varphi_{l_{\underline{X}},m}(X_{l_{\underline{X}}})) = \varphi_{l_{\underline{X}},n}(X_{l_{\underline{X}}}) \subseteq Y_n \cup \mathbb{Z}.$$

If  $m \geq n \geq l_{\underline{X}}$  then it follows from construction of  $\underline{Y}$  that  $\varphi_{m,n}(Y_m) \subseteq Y_n \cup \mathbb{Z}$ .

Now, let  $0 \leq n < l_{\underline{X}} \leq m$ . Then

$$\varphi_{m,n}(Y_m) \subseteq \varphi_{l_{\underline{X}},n} \circ \varphi_{l_{\underline{X}},m}(X_m) \subseteq \varphi_{l_{\underline{X}},n}(X_{l_{\underline{X}}} \cup \mathbb{Z}) \subseteq Y_n \cup \mathbb{Z}.$$

To sum up, we have that  $\varphi_{m,n}(Y_m) \subseteq Y_n \cup \mathbb{Z}$  for all  $m \geq n \geq 0$  and so  $\underline{Y}$  is  $S$ -complete. It then follows from the construction of  $\underline{X}$  and  $\underline{Y}$  and Lemma 6.3 that  $X(\underline{X}) = X(\underline{Y})$  and so  $\mathcal{X}(\underline{X}_S) \subseteq \{X(\underline{X}) \mid \underline{X} \in \underline{X}_S \text{ is } S\text{-complete}\}$  and we are done.  $\square$

## 6.2 Triangulations of linearly ordered sets

Throughout the rest of this chapter  $m, n \in \mathbb{Z}_{\geq 3}$  with  $m \geq n$ , unless stated otherwise. Before we look at some concrete examples of pro-clusters and pro-cluster algebras let us first prove

several technical results regarding certain linearly ordered sets and their triangulations. We will use those results repeatedly throughout the rest of this chapter.

Recall (cf. Definition 4.20) that if  $(J, <)$  is a linearly ordered set then we call a pair  $(x, y)$  of elements of  $(J, <)$  such that  $x < y$  an arc of  $(J, <)$ . Two arcs  $(x, y)$  and  $(k, l)$  of  $(J, <)$  cross if  $x < k < y < l$  or  $k < x < l < y$ . A triangulation (cf. Definition 4.21) of  $(J, <)$  is a maximal set of its pairwise non-crossing arcs.

Throughout this chapter, when we say that a set of arcs of a linearly ordered set is maximal, respectively not maximal, we always mean that it is maximal, respectively not maximal, as a set of pairwise non-crossing arcs of that set.

Now let us consider a linearly ordered set  $(J, <)$ . We adapt the convention that if  $J$  is infinite then it satisfies at least one of the following:

- (1) there exists the element, denoted by  $\infty^-$ , in the set  $J$  such that  $\infty^- < j$  for all  $j \in J \setminus \{\infty^-\}$ ,
- (2) there exists the element, denoted by  $\infty^+$ , in the set  $J$  such that  $j < \infty^+$  for all  $j \in J \setminus \{\infty^+\}$ ,
- (3) there exist unique elements, denoted by  $\infty^-, \infty^+$ , in the set  $J$  such that  $\infty^- < j < \infty^+$  for all  $j \in J \setminus \{\infty^-, \infty^+\}$ .

We will denote the set  $(J, <)$  that satisfies (1) only by  $J_{\infty^-}$  and (2) only by  $J_{\infty^+}$ . If  $(J, <)$  satisfies (3) then it automatically satisfies (1) and (2) and we will denote it by  $J_{\infty^\pm}$ .

**Lemma 6.8.** *Let  $T$  and  $T'$  be a triangulation of  $J_{\infty^-}$  and of  $J_{\infty^+}$ , respectively, and let  $i \in J_{\infty^-} \setminus \{\infty^-\}$  and  $i' \in J_{\infty^+} \setminus \{\infty^+\}$ . If*

- a) *a family  $\{j \in J_{\infty^-} \mid (j, i) \in T\}$  is infinite or a family  $\{j \in J_{\infty^-} \mid (i, j) \in T\}$  is infinite, then  $(\infty^-, i) \in T$*

and if

- b) *a family  $\{j \in J_{\infty^+} \mid (j, i') \in T'\}$  is infinite or a family  $\{j \in J_{\infty^+} \mid (i', j) \in T'\}$  is infinite, then  $(i', \infty^+) \in T'$ .*

*Proof.* First we prove a). The only arcs of  $J_{\infty^-}$  that cross  $(\infty^-, i)$  are of the form  $(k, l)$  with  $k < i < l$ . Let  $k < i$  and  $i < l$ . Since either  $\{j \in J_{\infty^-} \mid (j, i) \in T\}$  or  $\{j \in J_{\infty^-} \mid (i, j) \in T\}$  is infinite, there exists  $p < k$  such that  $(p, i) \in T$  or  $q > l$  such that  $(i, q) \in T$ . But then  $(p, i)$  and  $(i, q)$  intersect any arc of the form  $(k, l)$  with  $k < i < l$ . Thus,  $T$  only contains arcs that do not cross  $(\infty^-, i)$  and so  $(\infty^-, i) \in T$ , by maximality of  $T$ .

The proof of part b) is very similar to the proof of part a) and so for brevity we skip the details.  $\square$

Similarly, in the case of  $J_{\infty^\pm}$  we have the following result.

**Lemma 6.9.** *Let  $T$  be a triangulation of  $J_{\infty^\pm}$  and let  $i \in J_{\infty^\pm} \setminus \{\infty^-, \infty^+\}$ . If a family  $\{j \in J_{\infty^\pm} \mid (j, i) \in T\}$  is infinite then  $(\infty^-, i) \in T$ . Similarly, if a family  $\{j \in J_{\infty^\pm} \mid (i, j) \in T\}$  is infinite then  $(i, \infty^+) \in T$ .*

*Proof.* Assume first that  $\{j \in J_{\infty^\pm} \mid (j, i) \in T\}$  is infinite. The only arcs of  $J_{\infty^\pm}$  that cross  $(\infty^-, i)$  are of the form  $(k, l)$  with  $\infty^- < k < i < l \leq \infty^+$ . Let  $k < i$ . There exists  $p < k$  such that  $(p, i) \in T$ . Therefore  $(p, i)$  crosses any arc of the form  $(k, l)$  with  $\infty^- < k < i < l \leq \infty^+$ . Thus,  $T$  only contains arcs that do not cross  $(\infty^-, i)$  and so  $(\infty^-, i) \in T$ , by maximality of  $T$ .

The case where  $\{j \in J_{\infty^\pm} \mid (i, j) \in T\}$  is infinite is dealt with in an almost identical way as the one above and so we omit the details.  $\square$

Now, recall (cf. page 52) that if  $|J| = m$  then we denote the smallest element of  $J$  by  $m^-$  and the largest element of  $J$  by  $m^+$ . Moreover, for  $i \in J$  we will denote by  $i_-$ , if it exists, an element of  $J$  such that  $\{x \in J : i_- < x < i\} = \emptyset$  and by  $i_+$ , again if it exists, an element of  $J$  such that  $\{x \in J : i < x < i_+\} = \emptyset$ . We will denote by  $(J_n, <)$  a linearly ordered set where  $J_n = \{x_1, \dots, x_n\} \subset J$  is such that  $\{x \in J : x_i < x < x_{i+1}\} = \emptyset$  for all  $1 \leq i < n$  and where  $<$  is inherited from  $J$  and whenever we write  $(J_n, <) \subset (J, <)$  we always mean a linearly ordered set that is constructed in this way from a prescribed (finite or infinite) linearly ordered set  $(J, <)$ .

Fix  $(J, <)$  and  $(J_n, <) \subset (J, <)$ . For  $T$  a triangulation of  $(J, <)$  we denote by  $\mathbf{A}_{J_n(T)}$  a subset of arcs of  $J_n$  given by

$$\mathbf{A}_{J_n(T)} = \{(i, j) \in T \mid x_i \leq i < j \leq x_n\} \cup \{(x_1, x_n)\}.$$

If an arc  $(j, i)$  of  $(J, <)$  is such that  $j < x_1 < i < x_n$  we say that  $(j, i)$  is *left-rooted* in  $(J_n, <)$ . Similarly, if  $(i, j)$  is such that  $x_1 < i < x_n < j$  we say that  $(i, j)$  is *right-rooted* in  $(J_n, <)$ . See below for an example of an arc of  $(J, <)$  that is left-rooted (picture on the left) in  $(J_n, <)$  and of an arc of  $(J, <)$  that is right rooted (picture on the right) in  $(J_n, <)$ , where we regard  $(J, <)$  (respectively  $(J_n, <)$ ) as a disk with (possibly infinitely many) marked points labelled cyclically anticlockwise with the elements of  $(J, <)$  (respectively of  $(J_n, <)$ ). We will

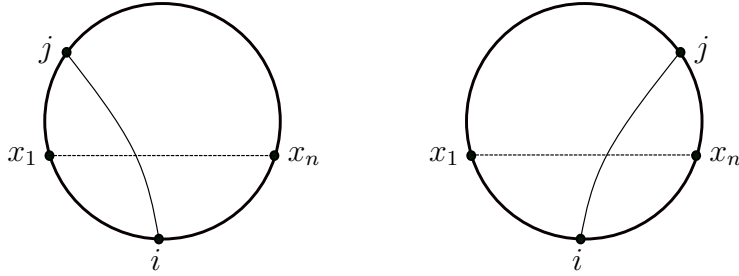

sometimes write that an arc is left-rooted or right-rooted, without explicitly stating the set  $(J_n, <)$  in which it is rooted, if no ambiguity is caused by such simplification. To make the notation even simpler we will refer to a linearly ordered set  $(J, <)$  simply as  $J$  and similarly, we will write  $J_n$  instead of  $(J_n, <)$ .

**Proposition 6.10.** *Let  $T, T'$  and  $T''$  be triangulations of  $J_{\infty\pm}, J_{\infty+}$  and of  $J_{\infty-}$ , respectively. Let  $T_n, T'_n$  and  $T''_n$  be sets of arcs of  $J_n \subset J_{\infty\pm}, J'_n \subset J_{\infty+}$  and of  $J''_n \subset J_{\infty-}$ , respectively, given by*

$$T_n = \mathbf{A}_{J_n(T)} \cup \{(i, x_n) \mid (i, j) \in T \text{ is right-rooted}\} \\ \cup \{(x_1, i) \mid (j, i) \in T \text{ is left-rooted}\},$$

$$T'_n = \mathbf{A}_{J'_n(T')} \cup \{(i, x_n) \mid (j, i) \in T' \text{ is left-rooted or } (i, j) \in T' \text{ is right-rooted}\},$$

$$T''_n = \mathbf{A}_{J''_n(T'')} \cup \{(x_1, i) \mid (j, i) \in T'' \text{ is left-rooted or } (i, j) \in T'' \text{ is right-rooted}\}.$$

*Then  $T_n, T'_n$  and  $T''_n$  are triangulations of  $J_n, J'_n$  and of  $J''_n$ , respectively.*

*Proof.* We will start with showing that  $T_n$  is a triangulation of  $J_n$ . First we show that the set  $T_n$  consists of pairwise non-crossing arcs of  $J_n$ . Let  $(i, j), (k, l) \in T_n$ . Assume first that  $(i, j), (k, l) \in \mathbf{A}_{J_n(T)}$ . That is,  $(i, j), (k, l) \in T$  and as  $(i, j)$  does not cross  $(k, l)$  in  $T$ , it follows that they do not cross in  $T_n$ .

Now, assume that  $(i, j) \notin \mathbf{A}_{J_n(T)}$  and that  $(k, l) \notin \mathbf{A}_{J_n(T)}$ . Thus,  $(i, j) \notin T$  and  $(k, l) \notin T$ . Then precisely one of the following cases holds:

**Case (1)**  $(i, j') \in T$  and  $(k, l') \in T$  for some  $j', l' \in J_{\infty^\pm}$  such that  $x_n < j', l' \leq \infty^+$ ;

**Case (2)**  $(i', j) \in T$  and  $(k', l) \in T$  for some  $i', k' \in J_{\infty^\pm}$  such that  $\infty^- \leq x_n < i', k' < x_1$ ;

**Case (3)**  $(i', j) \in T$  and  $(k, l') \in T$  for some  $i', k' \in J_{\infty^\pm}$  such that  $\infty^- \leq i' < x_1 < j \leq k < x_n < l' \leq \infty^+$ .

Assume that **Case (1)** holds. Then  $j = l = x_n$  and  $(i, x_n)$  does not cross  $(k, x_n)$ . Similarly, if **Case (2)** is true, then  $i = k = x_1$  and  $(x_1, j)$  does not cross  $(x_1, l)$ . Finally, if **Case (3)** is true then  $i = x_1$  and  $l = x_n$  and since  $j \leq k$  we then have that  $(x_1, j)$  does not cross  $(k, x_n)$ .

Next, assume that  $(i, j) \in \mathbf{A}_{J_n(T)}$  but  $(k, l) \notin \mathbf{A}_{J_n(T)}$ . That is,  $(i, j) \in T$  but  $(k, l) \notin T$ . Then either  $(k, l') \in T$  for some  $x_n < l' \leq \infty^+$  or  $(k', l) \in T$  for some  $\infty^- \leq k' < x_1$ . If  $(k, l') \in T$  then since  $(i, j) \in T$  we must have that either  $x_1 < k \leq i < j \leq x_n < l' \leq \infty^+$  or  $x_1 \leq i < j \leq k < x_n < l' \leq \infty^+$ . But then we have in both cases that  $(i, j)$  does not cross  $(k, l) = (k, x_n)$ . The case where  $(k', l) \in T$  is true by symmetry.

Now, to show that  $T_n$  is triangulation of  $J_n$  it is left to show that  $J_n$  is maximal. Suppose, for contradiction, that there exists an arc  $(i, j)$  of  $J_n$  such that it does not cross any of the arcs from  $T_n$ . Assume first that  $x_1 < i < j < x_n$ . But then  $(i, j) \notin \mathbf{A}_{J_n(T)}$  and so  $(i, j) \notin T$ . Suppose  $(k, l) \in T$  crosses  $(i, j)$ . Then either  $\infty^- \leq k < i < l < j < x_n$  or  $i < k < j < x_n \leq l \leq \infty^+$ . Thus, either  $(k, l) \in T_n$  or  $(x_1, l) \in T_n$  if  $\infty^- \leq k < i < l < j < x_n$  and  $(k, l) \in T_n$  or  $(k, x_n) \in T_n$  if  $i < k < j < x_n \leq l \leq \infty^+$ . Either of those cases results in a contradiction as each of the  $(k, l), (x_1, p), (k, x_n)$  crosses  $(i, j)$  in a given case. Therefore every arc in  $T$  does not cross  $(i, j)$  and so  $T$  is not maximal, i.e. not a triangulation, which is a contradiction.

Next, we assume that  $j = x_n$ . We have that  $(i, k) \notin T$  for all  $x_n \leq k \leq \infty^+$ . Now, either  $(k, i) \in T$  for some  $\infty^- \leq k < i_-$  or  $(i, p) \in T$  for some  $i_+ < p < x_n$ . If not, then

$(i_-, i_+) \in T$  by maximality of  $T$  and so  $(i_-, i_+) \in T_n$ . But then as  $(i, x_n)$  crosses  $(i_-, i_+)$  we get a contradiction. In fact,  $(k, i) \in T$  if and only if  $(i, p) \in T$ . To show this, assume first that  $(k, i) \in T$ . Moreover, let  $k$  be such that for every  $k' \neq k$  with  $(k', i) \in T$  we have that  $k < k'$ . Such  $k$  always exists due to Lemma 6.9. Assume for contradiction that  $(i, p) \notin T$ . Then  $(k, i_+) \in T$  by maximality of  $T$ . But then either  $(k, i_+) \in T_n$  if  $x_1 \leq k$  or  $(x_1, i_+) \in T_n$  if  $k < x_1$ . Both  $(k, i_+)$  and  $(x_1, i_+)$  cross  $(i, x_n)$  and so we get a contradiction in both cases.

On the other hand, assume that  $(i, p) \in T$  and suppose that  $(k, i) \notin T$ . Let  $p$  be such that for every  $p' \in J_n$  such that  $i_- < p' < i_+$  with  $(i, p') \in T$  we have that  $p' < p$ . Because we assumed that  $(k, i) \notin T$  for all  $\infty^- \leq k < i_-$  we have that  $(i_-, p) \in T$  and so  $(i_-, p) \in T_n$ . But again, as  $(i, x_n)$  crosses  $(i_-, p)$  we get yet another contradiction.

We established so far that if  $T_n$  is not maximal with  $(i, x_n)$  an arc of  $J_n$  that crosses no arc in  $T_n$  then we must have that  $(k, i) \in T$  and  $(i, p) \in T$  for some  $\infty^- \leq k < i_-$  and for some  $i_+ < p < x_n$ . Consider the smallest such  $k$  (smallest in the same sense as in the previous paragraph) and the largest such  $p$  (largest in the same sense as in the previous paragraph). We claim that  $(k, p) \in T$ . We have for such  $(k, p)$  that every arc of  $J_{\infty^\pm}$  that crosses  $(k, p)$  in  $T$  crosses either  $(k, i)$  or  $(i, p)$ . Thus no arc in  $T$  crosses  $(k, p)$  and so  $(k, p) \in T$ , by maximality of  $T$ . But then  $(k, p) \in T_n$  if  $x_1 < k$  or  $(x_1, p) \in T_n$  if  $\infty^- \leq k \leq x_1$ . If  $(k, p) \in T_n$  then as  $(k, p)$  crosses  $(i, x_n)$  we get a contradiction. Similarly, if  $(x_1, p) \in T_n$  then as  $(x_1, p)$  crosses  $(i, x_n)$  we get another contradiction.

The case where  $i = x_1 < j < x_n$  follows symmetrically and we can then deduce that  $T_n$  is maximal and as it consists of pairwise non-crossing arcs of  $J_n$  it is a triangulation of  $J_n$ , as required.

Next, we will show that  $T'_n$  is a triangulation of  $J'_n$ . That  $T''_n$  is a triangulation of  $J''_n$  will follow symmetrically. The proof of the claim that  $T'_n$  consists of pairwise non-crossing arcs is very similar to that of the fact that  $T_n$  consists of pairwise non-crossing arcs that was given above and so we skip the details of the calculations for brevity.

It is then left to show that  $T'_n$  is maximal. Assume, for contradiction, that there exists an arc  $(i, j)$  of  $J'_n$  that does not cross any of the arcs from  $T'_n$ . Assume first that  $x_1 \leq i < j < x_n$ . Then  $(i, j) \notin \mathbf{A}_{J'_n(T')}$  and so  $(i, j) \notin T'$ . Suppose  $(k, l) \in T'$  crosses  $(i, j)$ . Then either  $k < i < l < j$  or  $i < k < j < l$ . It follows that either  $(k, l) \in T'_n$  or  $(l, x_n) \in T'_n$  if

$k < i < l < j$  and  $(k, l) \in T'_n$  or  $(k, x_n) \in T'_n$  if  $i < k < j < l$ . Either of those cases leads to a contradiction as each of the arcs  $(k, l), (l, x_n), (k, x_n)$  crosses the arc  $(i, j)$  in a given case. Therefore no arc in  $T'$  crosses  $(i, j)$  and so  $T'$  is not maximal, i.e. not a triangulation, which is a contradiction.

Next, assume that  $x_1 < i < j = x_n$ . Then  $(k, i) \notin T'$  for all  $k < x_1$  and  $(i, p) \notin T'$  for all  $x_n \leq p \leq \infty^+$ , by definition of  $T'_n$ . Now either  $(k, i) \in T'$  for some  $x_1 \leq k < i_-$  or  $(i, p) \in T'$  for some  $i_+ < p < x_n$ . If not, then  $(i_-, i_+) \in T'$  and so  $(i_-, i_+) \in T'_n$ . Now since  $(i, x_n)$  crosses  $(i_-, i_+)$  we get a contradiction.

We have in fact that  $(k, i) \in T'$  if and only if  $(i, p) \in T'$ . Let  $k$  be such that for every  $k' \neq k$  with  $(k', i) \in T'$  we have that  $k < k'$ . Such  $k$  always exists as  $(k'', i) \notin T'$  for all  $k'' < x_1$ . Assume for contradiction that  $(i, p) \notin T'$ . Then  $(k, i_+) \in T'$  by maximality of  $T'$ . But then  $(k, i_+) \in T'_n$  and as  $(k, i_+)$  crosses  $(i, x_n)$  we get a contradiction. That if  $(i, p) \in T'$  then  $(k, i) \in T'$  follows symmetrically.

So far we established that if  $T'_n$  is not maximal with  $(i, x_n)$  an arc of  $J'_n$  that crosses no arc in  $T'_n$  then we must have that  $(k, i) \in T'$  and  $(i, p) \in T'$  for some  $x_1 \leq k < i_-$  and for some  $i_+ < p < x_n$ . Consider the smallest such  $k$  and the largest such  $p$ . We claim that  $(k, p) \in T'$ . We notice that every arc of  $J_{+\infty}$  that crosses  $(k, p)$  in  $T'$  crosses either  $(k, i)$  or  $(i, p)$ . Thus no arc in  $T'$  crosses  $(k, p)$  and so  $(k, p) \in T'$ , by maximality of  $T'$ . But then  $(k, p) \in T'_n$  and so  $(k, p)$  crosses  $(i, x_n)$  and we get yet another contradiction.

Now as  $T'_n$  is a maximal set of pairwise non-crossing arcs of  $J'_n$  it follows that  $T'_n$  is a triangulation of  $J'_n$ , as required.  $\square$

Let us assume that  $|J| = m$ . We will use a similar idea to that from Proposition 6.10 to construct from triangulations of  $J$  triangulations of  $J_n$ . The Corollary 6.11 given below will be used to show that certain freezing morphisms between cluster algebras from polygons map clusters to clusters.

Given any triangulation  $T$  of  $J$  we want to construct from it a triangulation of  $J_n$ . We



set

$$t_{(J,T) \rightarrow J_n} := \mathbf{A}_{J_n(T)} \cup \{(i, x_n) \mid (i, j) \in T \text{ is right-rooted}\} \\ \cup \{(x_1, i) \mid (j, i) \in T \text{ is left-rooted}\}$$

$$t_{(J,T) \rightarrow J_n}^{0,1} := \mathbf{A}_{J_n(T)} \cup \{(i, x_n) \mid (j, i) \in T \text{ is left-rooted or } (i, j) \in T \text{ is right-rooted}\},$$

$$t_{(J,T) \rightarrow J_n}^{1,0} := \mathbf{A}_{J_n(T)} \cup \{(x_1, i) \mid (j, i) \in T \text{ is left-rooted or } (i, j) \in T \text{ is right-rooted}\},$$

and claim, using the above notation, the following:

**Corollary 6.11.** *The sets  $t_{(J,T) \rightarrow J_n}^{0,1}$ ,  $t_{(J,T) \rightarrow J_n}^{1,0}$  and  $t_{(J,T) \rightarrow J_n}$  of arcs of  $J_n$  are triangulations of  $J_n$ .*

*Proof.* Consider an infinite linearly ordered set  $J_{\infty^\pm}$  and let  $J_m \subset J_{\infty^\pm}$ . We have that  $J = J_m$  up to isomorphism of linearly ordered sets and that  $J_n \subset J_{\infty^\pm}$  since  $J_n \subset J_m$ . Let  $T'$  be a triangulation of  $J_{\infty^\pm}$  with its internal arcs given by a set  $T \cup \{(\infty^-, i) \mid \infty^- < i < x_1\} \cup \{(\infty^-, x_m)\} \cup \{(i, \infty^+) \mid x_m \leq i < \infty^+\}$ . We have by Proposition 6.10 that the set

$$\mathbf{A}_{J_n(T')} \cup \{(i, x_n) \mid (i, j) \in T' \text{ is right-rooted}\} \cup \{(x_1, i) \mid (j, i) \in T' \text{ is left-rooted}\}$$

is a triangulation of  $J_n$ . But by construction of  $T'$  we have that the above set is equal to  $t_{(J,T) \rightarrow J_n}$  and so  $t_{(J,T) \rightarrow J_n}$  is a triangulation of  $J_n$ , as required.

Similarly, consider an infinite linearly ordered set  $J_{\infty^+}$  and let  $J_m \subset J_{\infty^+}$ . Again, we have that  $J = J_m$  up to order-preserving bijection and that  $J_n \subset J_{\infty^+}$ . Now, let  $T''$  be a triangulation of  $J_{\infty^+}$  with its internal arcs given by a set  $T \cup \{(i, \infty^+) \mid i \leq x_1 \text{ or } i \geq x_m\}$ . Then we have by Proposition 6.10 that the set

$$\mathbf{A}_{J_n(T'')} \cup \{(i, x_n) \mid (j, i) \in T'' \text{ is left-rooted or } (i, j) \in T'' \text{ is right-rooted}\}$$

is a triangulation of  $J_n$ . But then by construction of  $T''$  we have that the above set is equal to  $t_{(J,T) \rightarrow J_n}^{0,1}$  and so  $t_{(J,T) \rightarrow J_n}^{0,1}$  is a triangulation of  $J_n$ . That  $t_{(J,T) \rightarrow J_n}^{1,0}$  is a triangulation of  $J_n$  follows symmetrically and we are done.  $\square$

### 6.3 Fountain pro-cluster algebras

In this section we will see that the pro-clusters arising from the inverse system  $(\mathcal{A}(\mathcal{T}_m^f), f_{m,n}^{0,1})$  are identified with triangulations of a linearly ordered set  $(\mathbb{Z}_{>0} \cup \{\infty\}, \leq)$ , where  $\leq$  is the

usual *less or equal to relation* and with the convention that  $j < \infty$  for all  $j \in \mathbb{Z}_{>0}$ , and we will compute the pro-cluster algebra  $\mathcal{A}((\mathcal{A}(\mathcal{T}_m^f), f_{m,n}^{0,1}))$ .

**Remark 6.12.** We note here that  $(\mathbb{Z}_{>0} \cup \{\infty\}, \leq)$  can be seen as the unit disk with countably many marked points on its boundary, which converge to the limit marked point  $\infty$  in an anticlockwise direction and where there are no marked points between (the marked points labelled by) 1 and  $\infty$  in a clockwise direction. See Figure 9 below for an example of a two-dimensional disk with its marked points (black dots) labelled cyclically anticlockwise with the integers from  $\mathbb{Z}_{>0}$  and a single marked accumulation point (open circle) labelled by  $\infty$ . (Also see [7] and [10] for more details regarding infinitely marked surfaces). This is an example of an *infinite marked surface*, [7, Definition 1.1], a generalization of a marked surface with finitely many marked points, and we will sometimes refer to  $(\mathbb{Z}_{>0} \cup \{\infty\}, \leq)$  as  *$\infty$ -gon with one-sided accumulation point*, for the reasons explained above.

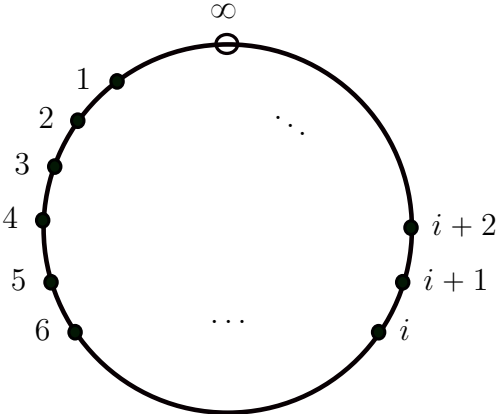

Figure 9: Unit disk with infinitely many marked points and a single one-sided marked accumulation point.

Throughout this chapter when we say that a cluster in a finite type  $A$  cluster algebra is maximal respectively not maximal we are referring to its underlying set of arcs of the suitable convex polygon, or equivalently, of the suitable linearly ordered set. Moreover, if  $x_{ij}$  is an exchangeable variable in a cluster algebra associated with a polygon, with  $(i, j)$  a diagonal of that polygon, then we will often call it simply a diagonal, if no ambiguity is caused by doing so. Similarly, if a cluster variable corresponds to a boundary arc we will sometimes call such a cluster variable an edge.

Recall that  $m, n \in \mathbb{Z}_{\geq 3}$  with  $m \geq n$ , unless stated otherwise. Let  $\mathcal{P}_m$  be a disk with  $m$  marked points on its boundary that we now label cyclically anticlockwise with integers 1 to  $m$ . Recall that the fountain triangulation at 1 of  $\mathcal{P}_m$ , denoted by  $\mathcal{T}_m^f$ , is a triangulation of  $\mathcal{P}_m$  such that all of the internal arcs in  $\mathcal{T}_m^f$  originate from 1. Consider the family  $\{\Sigma_{\mathcal{T}_m^f} \mid m \geq 3\}$  of seeds associated with the fountain triangulation at 1 of  $\mathcal{P}_m$ . Throughout the rest of this section we denote by:

- $C$  the inverse system  $(\mathcal{A}(\mathcal{T}_m^f), f_{m,n}^{0,1})$  in the category **fClus**
- $(R_C, (f_m)_{m \geq 3})$  its limit in **Ring**.

Recall that the freezing morphism  $f_{m,n}^{0,1} : \mathcal{A}(\mathcal{T}_m^f) \rightarrow \mathcal{A}(\mathcal{T}_n^f)$  is given by (see Corollary 5.43) the algebraic extension of the map

$$x_{ij} \mapsto \begin{cases} x_{ij}, & 1 \leq i < j \leq n \\ x_{in}, & 1 \leq i < n < j \leq m \\ 0, & n \leq i < j \leq m. \end{cases}$$

**Proposition 6.13.** *Let  $\mathcal{T}_m'$  be a triangulation of  $\mathcal{P}_m$  and let  $X_{\mathcal{T}_m'}$  be the corresponding cluster in  $\mathcal{A}(\Sigma_{\mathcal{T}_m'})$ . Then  $f_{m,n}^{0,1}(X_{\mathcal{T}_m'}) \setminus \{0\}$  is a cluster in  $\mathcal{A}(\Sigma_{\mathcal{T}_n^f})$ , for all  $n < m$ .*

*Proof.* Let  $J := (\{1, \dots, m\}, \leq)$ ,  $J_n := (\{1, \dots, n\}, \leq)$  be linearly ordered sets with  $\leq$  the usual less or equal to relation. Regarding  $\mathcal{T}_m'$  as a triangulation of  $J$ , we have that  $t_{(J, \mathcal{T}_m') \rightarrow J_n}$  is a triangulation of  $J_n$  by Corollary 6.11, or equivalently, of  $\mathcal{P}_n$ . But then we have that  $f_{m,n}^{0,1}(X_{\mathcal{T}_m'}) \setminus \{0\} = \{x_{ij} \mid (i, j) \in t_{(J, \mathcal{T}_m') \rightarrow J_n}\}$  by Corollary 5.43. Thus  $f_{m,n}^{0,1}(X_{\mathcal{T}_m'}) \setminus \{0\}$  corresponds to a triangulation of  $\mathcal{P}_n$  and so it is a cluster, as required.  $\square$

In what follows we will only consider complete  $C$ -admissible sequences and their associated pro-clusters. We show in the Corollary 6.15 below that no generality is lost by doing so. First, let us look at an example of a complete  $C$ -admissible sequence.

**Example 6.14.** Let  $\underline{X} = (X_{\mathcal{T}_m^f})_{m \geq 3}$ . Then  $f_{m,n}^{0,1}(X_{\mathcal{T}_m^f}) = X_{\mathcal{T}_n^f} \cup \{0\}$  for all  $m \geq n \geq 3$  and so  $\underline{X}$  is  $C$ -complete. In Figure 10 we show the triangulations corresponding to the clusters

$X_{\mathcal{T}_m^f}$  for  $m = 3, 4, 5, 6$ , where the green diagonals are those to which the triangle is getting collapsed under the action of  $f_{m,n}^{0,1}$ . That is  $f_{6,5}^{0,1}$  collapses the triangle on the marked points 1, 5, 6 to the edge connecting 1 to 5, then  $f_{5,4}^{0,1}$  collapses the triangle on the marked points 1, 4, 5 to the edge connecting 1 to 4 and so on.

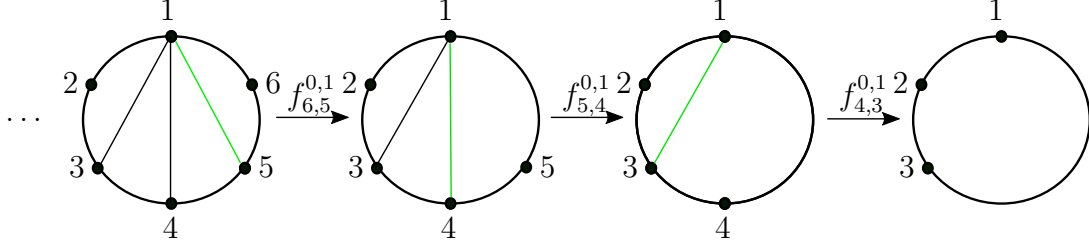

Figure 10: The front tail of the  $C$ -complete admissible sequence  $(X_{\mathcal{T}_m^f})_{m \geq 3}$ .

**Corollary 6.15.** *Recall that  $\underline{X}_C$  is the set of all  $C$ -admissible sequences and that  $\mathcal{X}(\underline{X}_C)$  is the set of all pro-clusters coming from all of the sequences in  $\underline{X}_C$ . Then*

$$\mathcal{X}(\underline{X}_C) = \{X(\underline{X}) \mid \underline{X} \in \underline{X}_C \text{ is } C\text{-complete}\}$$

.

*Proof.* The claim follows from Proposition 6.7 and Proposition 6.13. □

Now, for  $1 \leq i < j < \infty$  set  $\tilde{x}_{ij} \in R_C$  to be the unique element of  $R_C$  such that  $f_m(\tilde{x}_{ij}) = x_{ij} \in \mathcal{A}(\Sigma_{\mathcal{T}_m^f})$  for all  $m > j > i \geq 1$  and set  $\tilde{x}_{i\infty} \in R_C$  to be the unique element of  $R_C$  such that  $f_m(\tilde{x}_{i\infty}) = x_{im} \in \mathcal{A}(\Sigma_{\mathcal{T}_m^f})$  for all  $m > i \geq 1$ . We will show that every element of a pro-cluster arising from a  $C$ -admissible sequence is of the form  $\tilde{x}_{ij}$  for some  $1 \leq i < j \leq \infty$ . To do that, we will need the following lemma.

**Lemma 6.16.** *Let  $\tilde{x}_{ij} \in R_C$ . Then*

$$f_m(\tilde{x}_{ij}) = \begin{cases} x_{ij}, & j \leq m \\ x_{im}, & 1 \leq i < m < j \leq \infty \\ 0, & m \leq i < j \leq \infty. \end{cases}$$

*Proof.* Consider first  $\tilde{x}_{ij} \in R_C$  such that  $1 \leq i < j < \infty$ . Then  $f_m(\tilde{x}_{ij}) = x_{ij}$  for all  $m > j > i \geq 1$ . Then since  $(R_C, (f_m)_{m \geq 3})$  is a cone over  $C$ , we have that

$$\begin{aligned} f_{m,n}(f_m(\tilde{x}_{ij})) &= f_{m,n}(x_{ij}) \\ &= \begin{cases} x_{in}, & 1 \leq i \leq n \leq j \\ 0, & n \leq i < j < m \end{cases} \\ &= f_n(\tilde{x}_{ij}). \end{aligned}$$

Thus we have that

$$f_m(\tilde{x}_{ij}) = \begin{cases} x_{ij}, & j \leq m \\ x_{im}, & 1 \leq i < m < j < \infty \\ 0, & m \leq i < j < \infty. \end{cases}$$

Next we consider  $\tilde{x}_{i\infty} \in R_C$ . Then for all  $m > i \geq 1$  we have that  $f_m(\tilde{x}_{i\infty}) = x_{im}$ . Then again, since  $(R_C, (f_m)_{m \geq 3})$  is a cone over  $C$ , we have that

$$\begin{aligned} f_{m,n}(f_m(\tilde{x}_{i\infty})) &= f_{m,n}(x_{im}) \\ &= \begin{cases} x_{in}, & 1 \leq i < n \\ 0, & n \leq i < m \end{cases} \\ &= f_n(\tilde{x}_{i\infty}). \end{aligned}$$

Therefore,

$$f_m(\tilde{x}_{i\infty}) = \begin{cases} x_{im}, & 1 \leq i < m \\ 0, & m \leq i < \infty. \end{cases}$$

Merging the two case distinctions together, we get that for any  $\tilde{x}_{ij} \in R_C$ ,

$$f_m(\tilde{x}_{ij}) = \begin{cases} x_{ij}, & j \leq m \\ x_{im}, & 1 \leq i < m < j \leq \infty \\ 0, & m \leq i < j \leq \infty, \end{cases}$$

as required. □

**Lemma 6.17.** *Let  $\underline{X} = (X_m)_{m \geq 3}$  be a complete  $C$ -admissible sequence and let  $x \in X(\underline{X})$ . Then  $x = \tilde{x}_{ij}$  for some  $1 \leq i < j \leq \infty$ .*

*Proof.* We have that  $f_n(x) \in X_n$  for some  $n \geq 3$  or  $f_n(x) \in \mathbb{Z}$  for all  $n \geq 3$ . If  $f_n(x) \in \mathbb{Z}$  for all  $n \geq 3$ , then  $x \in \mathbb{Z}$ , a contradiction.

Let us assume now that  $f_n(x) \in X_n$  for some  $n \geq 3$ . If  $f_m(x) \in \mathbb{Z}$  for some  $m > n$ , then  $f_n(x) = f_{m,n}(f_m(x)) \in \mathbb{Z}$ , a contradiction. Thus  $f_m(x) \in X_m$  for all  $m > n$ . Now since  $f_n(x) \in X_n$ , it follows that  $f_n(x) = x_{ij}$  for some  $1 \leq i < j \leq n$ . If  $j = n$  then either  $f_m(x) = x_{im}$  for all  $m > n$  or there exists an integer  $k > n$  such that  $f_m(x) = x_{ik}$  for all  $m \geq k$  and if  $j < m$  then  $f_m(x) = x_{ij}$  for all  $m > n$ . But then  $x = \tilde{x}_{i\infty}$  or  $x = \tilde{x}_{ik}$ , or  $x = \tilde{x}_{ij}$ , respectively, which follows from the uniqueness of the elements  $\tilde{x}_{i\infty}$ ,  $\tilde{x}_{ik}$  and  $\tilde{x}_{ij}$ .  $\square$

The following result is a direct consequence of the above Lemma 6.17 and Corollary 6.15.

**Corollary 6.18.** *Let  $\underline{X} = (X_m)_{m \geq 3}$  be a  $C$ -admissible sequence and let  $x \in X(\underline{X})$ . Then  $x = \tilde{x}_{ij}$  for some  $1 \leq i < j \leq \infty$ .*

As a consequence of the Corollary 6.18 above we will from now on denote an element of a pro-cluster  $X(\underline{X})$ , for any  $C$ -admissible sequence  $\underline{X}$ , simply by  $\tilde{x}_{ij}$ , without further explanation.

We will now consider a linearly ordered set  $(\mathbb{Z}_{>0} \cup \{\infty\}, \leq)$  where  $\leq$  is the usual less or equal to relation and with the convention that  $j < \infty$  for all  $j \in \mathbb{Z}_{>0}$ . We will show that pro-clusters arising from (complete)  $C$ -admissible sequences coincide with triangulations of  $(\mathbb{Z}_{>0} \cup \{\infty\}, \leq)$ . We notice that if  $T$  is a triangulation of  $(\mathbb{Z}_{>0} \cup \{\infty\}, \leq)$  then  $(1, \infty) \in T$  as no arc of  $(\mathbb{Z}_{>0} \cup \{\infty\}, \leq)$  crosses  $(1, \infty)$  and so by maximality of  $T$  we have that  $(1, \infty) \in T$ .

Next we show that every triangulation of  $(\mathbb{Z}_{>0}, \leq)$  gives rise to a pro-cluster.

**Lemma 6.19.** *Let  $T$  be a triangulation of  $(\mathbb{Z}_{>0} \cup \{\infty\}, \leq)$ . Then  $X_T := \{\tilde{x}_{ij} \mid (i, j) \in T\} \in X(\underline{X}_C)$ .*

*Proof.* Throughout this proof  $J_n$  denotes a linearly ordered set  $(\{1, 2, \dots, n\}, \leq)$ , for any  $n \geq 3$ , with  $\leq$  being the less or equal to relation, as usual. Moreover, we let

$$T_n = \{(i, j) \in T \mid 1 \leq i < j \leq n\} \cup \{(i, n) \mid (i, j) \in T \text{ such that } 1 \leq i < n < j \leq \infty\}.$$

We claim that the sequence  $\underline{X} := (X_{T_n})_{n \geq 3}$  is  $C$ -complete, where we regard  $T_n$  as a triangulation of  $\mathcal{P}_n$ , and that  $X(\underline{X}) = X_T$ .

By Proposition 6.10 we have that  $T_n$  is a triangulation of  $J_n$ , or equivalently of  $\mathcal{P}_n$ , for all  $n \geq 3$ . Moreover, using Proposition 6.10 in a duet with Lemma 6.16 we have that  $X_{T_n} = f_n(X_T) \setminus \mathbb{Z}$  for all  $n \geq 3$ . To show that  $\underline{X}$  is  $C$ -complete we have to show that  $f_{m,n}^{0,1}(X_{T_m}) \subseteq X_{T_n} \cup \mathbb{Z}$  for all  $m \geq n \geq 3$ . We have that

$$f_{m,n}^{0,1}(X_{T_m}) = f_{m,n}^{0,1}(f_m(X_T) \setminus \mathbb{Z}) \subseteq f_{m,n}^{0,1}(f_m(X_T)) = f_n^{0,1}(X_T) \subseteq X_{T_n} \cup \mathbb{Z}$$

and so  $\underline{X}$  is  $C$ -complete, as required.

To conclude the claim it is now left to show that  $X(\underline{X}) = X_T$ . First, let  $\tilde{x}_{ij} \in X(\underline{X})$  be such that  $j < \infty$ . Then  $f_n(\tilde{x}_{ij}) = x_{ij} \in X_{T_n}$  for all  $n \geq j$ . Using this and the construction of  $T_n$  we conclude that  $(i, j) \in T$  and so  $\tilde{x}_{ij} \in X_T$ . Now, if  $j = \infty$ , then  $f_n(\tilde{x}_{i\infty}) = x_{in} \in X_{T_n}$  for all  $n > i$ . But then this and how  $T_n$  is constructed imply that  $(i, \infty) \in T$  and so  $x_{i\infty} \in X_T$ , as required.

On the other hand, let  $\tilde{x}_{ij} \in X_T$ . Then  $(i, j) \in T$  and so if  $j < \infty$  we have that  $(i, j) \in T_n$  for all  $n \geq j$  and so  $f_n(\tilde{x}_{ij}) \in X_{T_n}$  for all  $n \geq j$ . Else, if  $j = \infty$  then as  $(i, \infty) \in T$  we have that  $(i, n) \in T_n$  for all  $n > i$  and so  $f_n(\tilde{x}_{i\infty}) = x_{in} \in X_{T_n}$  for all  $n > i$ . But then we have in both cases that since  $\underline{X}$  is a complete  $C$ -admissible sequence and since  $\tilde{x}_{ij} \in R_C$  it follows that  $f_{m,n}^{0,1}(f_m(\tilde{x}_{ij})) = f_n(\tilde{x}_{ij}) \in X_{T_n} \cup \{0\}$  for all  $m \geq n \geq 3$ .  $\square$

We will now show that pro-clusters arising from  $C$  yield triangulations of  $\mathbb{Z}_{>0} \cup \{\infty\}$ .

**Lemma 6.20.** *Let  $\underline{X} = (X_n)_{n \geq 3}$  be a complete  $C$ -admissible sequence. Let  $T = \{(i, j) \mid \tilde{x}_{ij} \in X(\underline{X})\}$ . Then  $T$  is a triangulation of  $(\mathbb{Z}_{>0} \cup \{\infty\}, \leq)$ .*

*Proof.* Suppose there exists  $\tilde{x}_{ij} \in X(\underline{X})$  and  $\tilde{x}_{kl} \in X(\underline{X})$  such that  $(i, j)$  crosses  $(k, l)$ . Without loss of generality we will assume that  $i < k$ . Then  $1 \leq i < k < j < l \leq \infty$ . If  $l < \infty$  then  $f_l(\tilde{x}_{ij}) = x_{ij} \in X_l$  and  $f_l(\tilde{x}_{kl}) = x_{kl} \in X_l$  and since  $(i, j)$  crosses  $(k, l)$  we have that  $X_l$  is not a cluster, a contradiction. Else, if  $l = \infty$  then  $f_{j+1}(\tilde{x}_{ij}) = x_{ij} \in X_{j+1}$  and  $\tilde{f}_{j+1}(\tilde{x}_{k\infty}) = x_{kj+1} \in X_{j+1}$  and since  $(i, j)$  crosses  $(k, j+1)$  we have that  $X_{j+1}$  is not a cluster, another contradiction. Therefore  $T$  consists of pairwise non-crossing arcs of  $(\mathbb{Z}_{>0} \cup \{\infty\}, \leq)$ .

To prove the claim we must now show that  $T$  is maximal. Let us suppose that there exists an arc  $(k, l)$  in  $(\mathbb{Z}_{>0} \cup \{\infty\}, \leq)$  such that  $\tilde{x}_{kl} \notin X(\underline{X})$  and such that  $(k, l)$  does not cross any of the arcs from  $T$ . Since  $\tilde{x}_{kl} \notin X(\underline{X})$ , there must exist  $m \geq 3$  for which  $\tilde{x}_{kl} \notin f_m^{-1}(X_m \cup \mathbb{Z})$ . Consider a  $\tilde{x}_{ij} \in X(\underline{X})$  such that  $\tilde{x}_{ij} \in f_m^{-1}(X_m)$ . We note that  $f_m(\tilde{x}_{kl})$  is a cluster variable which follows from the fact that  $f_m(\tilde{x}_{kl}) \notin \mathbb{Z}$  and Lemma 6.16. That is,  $f_m(\tilde{x}_{kl}) = x_{kl'}$  for some  $1 < l' \leq m$ . Because  $\tilde{x}_{ij} \in f_m^{-1}(X_m)$  we have that  $f_m(\tilde{x}_{ij}) = x_{ij'}$  for some  $1 < j' \leq m$ . Suppose that  $(k, l')$  crosses  $(i, j')$  in  $\mathcal{P}_m$ . Then either  $1 \leq i < k < j' < l' \leq m$  or  $1 \leq k < i < l' < j' \leq m$ . We will only consider the former case as the latter case is dealt with analogously. We have that if  $l' < m$  then  $l = l'$  and  $j = j'$  and so  $(k, l)$  crosses  $(i, j)$  which is a contradiction. Else, if  $l' = m$  then  $l \geq m$  and  $(i, j) = (i, j')$ . This implies that  $1 \leq i < k < j < m \leq l \leq \infty$  and so  $(k, l)$  crosses  $(i, j)$ , another contradiction. Thus we have that  $f_m(\tilde{x}_{kl})$  and  $f_m(\tilde{x}_{ij})$  do not cross in  $\mathcal{P}_m$ . But then since  $\tilde{x}_{kl} \notin f_m^{-1}(X_m)$ , we have that the triangulation corresponding to  $X_m$  is not maximal and so  $X_m$  is not a cluster, a contradiction.

We conclude that  $T$  is a triangulation of  $(\mathbb{Z}_{>0} \cup \{\infty\}, \leq)$ , as required.  $\square$

Recall (cf. page 105) that we denote by  $\mathcal{X}(\underline{X}_C)$  the set of all pro-cluster arising from  $C$ .

**Theorem 6.21.** *The set  $\mathcal{X}(\underline{X}_C)$  is the set*

$$\left\{ X_T \mid T \text{ is a triangulation of } \mathbb{Z}_{>0} \cup \{\infty\} \right\},$$

where  $X_T = \{\tilde{x}_{ij} \in R \mid (i, j) \in T\}$  for any triangulation  $T$  of  $\mathbb{Z}_{>0} \cup \{\infty\}$ .

*Proof.* We have by Corollary 6.15 that  $\mathcal{X}(\underline{X}_C) = \{X(\underline{X}) \mid \underline{X} \text{ is } C\text{-complete}\}$ . Then by Lemma 6.20 we have that

$$\mathcal{X}(\underline{X}_C) \subseteq \left\{ X_T \mid T \text{ is a triangulation of } \mathbb{Z}_{>0} \cup \{\infty\} \right\}.$$

Moreover,

$$\left\{ X_T \mid T \text{ is a triangulation of } \mathbb{Z}_{>0} \cup \{\infty\} \right\} \subseteq \mathcal{X}(\underline{X}_C),$$

by Lemma 6.19, and so

$$\mathcal{X}(\underline{X}_C) = \left\{ X_T \mid T \text{ is a triangulation of } \mathbb{Z}_{>0} \cup \{\infty\} \right\},$$

as required.  $\square$



**Example 6.22.** It is easy to see that from the  $C$ -admissible sequence  $\underline{X} = (X_{\mathcal{T}_m^f})_{m \geq 3}$  (see Example 6.14) we get the pro-cluster  $X(\underline{X}) = \{\tilde{x}_{ii+1} \mid i \in \mathbb{Z}_{>0}\} \cup \{\tilde{x}_{1i} \mid 2 < i \leq \infty\}$ . Moreover, the set  $T$  of arcs of  $(\mathbb{Z}_{>0} \cup \{\infty\}, \leq)$  given by  $T = \{(i, j) \mid \tilde{x}_{ij} \in X(\underline{X})\}$  is a triangulation of  $(\mathbb{Z}_{>0} \cup \{\infty\}, \leq)$ . See Figure 11, where we regard  $(\mathbb{Z}_{>0} \cup \{\infty\}, \leq)$  as a two-dimensional disk with infinitely many marked points and a single marked accumulation point  $\infty$ , which we denote by an open circle.

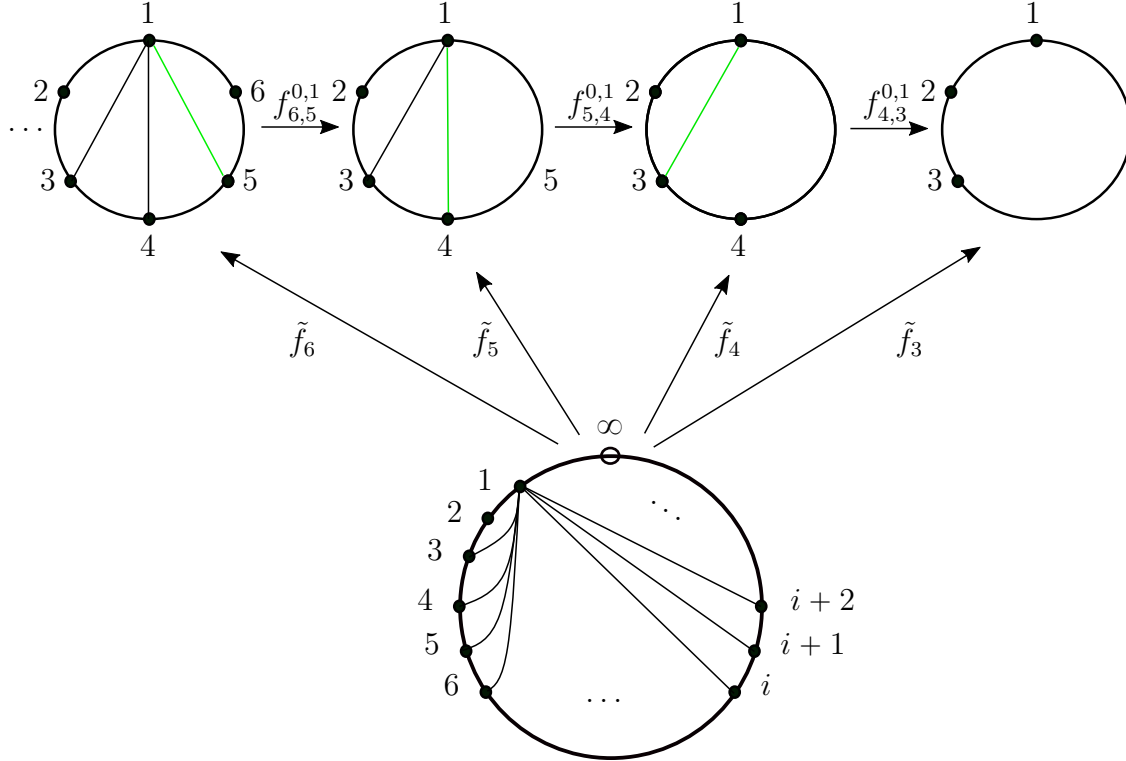

Figure 11: The front tail of the  $C$ -complete admissible sequence  $\underline{X} = (X_{\mathcal{T}_m^f})_{m \geq 3}$  and the triangulation of  $(\mathbb{Z}_{>0} \cup \{\infty\}, \leq)$  corresponding to the pro-cluster  $X(\underline{X})$

It is the direct consequence of the above proposition (and the definition of a pro-cluster algebra) that the pro-cluster algebra associated with  $C$  is generated by all of the arcs of  $(\mathbb{Z}_{>0} \cup \{\infty\}, <)$ .

**Corollary 6.23.** *The pro-cluster algebra  $\mathcal{A}(C)$  is a subring of  $R_C$  generated by the set*

$$\{\tilde{x}_{ij} \mid 1 \leq i < j \leq \infty\}.$$

It turns out that the generators of  $\mathcal{A}(C)$  are subject to what can be thought of as a generalization of Plücker relations (see page 53), as the following Theorem 6.24 will show.

**Theorem 6.24.** *The pro-cluster algebra  $\mathcal{A}(C)$  is the ring*

$$\frac{\mathbb{Z}[x_{ij} | 1 \leq i < j \leq \infty]}{(x_{ik}x_{jl} - x_{ij}x_{kl} - x_{jk}x_{il} \text{ for } 1 \leq i < j < k < l \leq \infty)}.$$

*Proof.* Let  $S = \mathbb{Z}[x_{ij} | 1 \leq i < j \leq \infty]$ . We denote by  $\alpha$  an element of the set  $\mathbb{N}_0^{\mathbb{N}_0 \times \mathbb{N}_0 \cup \{\infty\}}$  with finite support and such that  $\alpha(i, j) = 0$  whenever  $i \geq j$  and by  $x^\alpha$  the corresponding monomial in  $S$ . We let  $\|\alpha\| := \max\{j : \alpha(i, j) > 0 \text{ or } \alpha(j, \infty) > 0\}$ .

By universal property of polynomial rings there exists a unique ring homomorphism  $\phi : S \rightarrow \mathcal{A}(C)$  such that  $\phi(x_{ij}) = \tilde{x}_{ij}$  for all  $1 \leq i < j \leq \infty$ . Since the elements  $\tilde{x}_{ij}$  generate  $\mathcal{A}(C)$  it follows that  $\phi$  is surjective. Thus  $\mathcal{A}(C) = S/J$  for some ideal  $J$  of  $S$ . We claim that  $J = P$  where  $P := (x_{ik}x_{jl} - x_{ij}x_{kl} - x_{jk}x_{il} \text{ for } 1 \leq i < j < k < l \leq \infty) \subseteq S$ . First, let  $x \in P$ . That is,

$$x = \sum_{1 \leq i < j < k < l \leq \infty} f_{ijkl}(x_{ik}x_{jl} - x_{ij}x_{kl} - x_{jk}x_{il})$$

where  $f_{ijkl} \in S$  and with  $f_{ijkl} = 0$  for all but finitely many  $(i, j, k, l) \in (\mathbb{N} \cup \{\infty\})^4$  such that  $1 \leq i < j < k < l \leq \infty$ . Let  $m \in \mathbb{Z}_{\geq 3}$  be such that  $m > k$  if  $f_{ijkl} \neq 0$  and  $l = \infty$  and such that  $m > l$  if  $f_{ijkl} \neq 0$  and  $l < \infty$ . Then  $f_n(\phi(x)) = 0$  for all  $n \geq m$  due to Lemma 6.16 and the fact that

$$\mathcal{A}(\Sigma_{\mathcal{T}_m^f}) = \frac{\mathbb{Z}[x_{ij} | 1 \leq i < j \leq m]}{(x_{ik}x_{jl} = x_{ij}x_{kl} + x_{jk}x_{il} \text{ for } 1 \leq i < j < k < l \leq m)}.$$

In fact, since  $(R_C, f_m)$  is a cone of  $(\mathcal{A}(\mathcal{T}_m^f), f_{m,n}^{0,1})$ , it follows that  $f_n(\phi(x)) = 0$  for all  $n \geq 3$  and so  $\phi(x) = 0$ . Thus  $x \in J$ .

On the other hand we have

$$S \longrightarrow S/J = \mathcal{A}(C) \hookrightarrow R_C \longrightarrow \mathcal{A}(T_n),$$

where the first map is the projection, the second map is the embedding and the last map is the map  $f_n$ . We denote by  $\tilde{f}_n$  the composite of these three maps. We have that  $\tilde{f}_n(x_{ij}) = f_n(\tilde{x}_{ij})$  for all  $1 \leq i < j \leq \infty$  and for all  $n \geq 3$ . Let  $r \in J \subseteq S$ . Now  $r = \sum a_\alpha x^\alpha$  is a linear combination of monomials  $x^\alpha$  with all but finitely many integral coefficients  $a_\alpha$  equal to zero. Let  $m \in \mathbb{Z}_{\geq 3}$  be such that for every monomial  $x^\alpha$  with non-zero coefficient (in  $r$ ) we have that  $m > \|\alpha\|$ . Such  $m$  always exists since all but finitely many coefficients are equal

to zero. Assume that  $r \notin P$ . But then because  $\tilde{f}_m(x_{ij}) = f_m(\tilde{x}_{ij})$  for all  $1 \leq i < j \leq \infty$  and Lemma 6.16 we have that

$$\mathcal{A}(\Sigma_{\mathcal{T}_m^f}) \neq \frac{\mathbb{Z}[x_{ij} | 1 \leq i < j \leq m]}{(x_{ik}x_{jl} = x_{ij}x_{kl} + x_{jk}x_{il} \text{ for } 1 \leq i < j < k < l \leq m)},$$

giving us a contradiction. Thus we have that  $r \in P$  and so  $J = P$ , as required.  $\square$

**Remark 6.25.** It is easy to see that  $\mathcal{A}(C) \neq R_C$ . For example  $\sum_{i \geq 2} \tilde{x}_{ii+1} \in R_C$  but  $\sum_{i \geq 2} \tilde{x}_{ii+1} \notin \mathcal{A}(C)$ .

## 6.4 Leapfrog pro-cluster algebras

### 6.4.1 Two one-sided limit points leapfrog pro-cluster algebra

In this section we will consider the inverse system  $(\mathcal{A}(\mathcal{T}_m^{zz}), z_{m,n})$  where  $z_{m,n} : \mathcal{A}(\mathcal{T}_m^{zz}) \rightarrow \mathcal{A}(\mathcal{T}_n^{zz})$  is the freezing rooted cluster morphism from Example 5.47 and where  $\mathcal{T}_m^{zz}$  is a zig-zag triangulation of a (suitably labelled) convex  $m$ -gon. We will show that the pro-clusters arising from  $(\mathcal{A}(\mathcal{T}_m^{zz}), z_{m,n})$  coincide with triangulations of the linearly ordered set  $(\mathbb{Z} \cup \{\pm\infty\}, \leq)$ , where  $\leq$  is the usual less or equal to relation together with the convention that  $-\infty$  and  $+\infty$  are such that  $-\infty < i < +\infty$  for every  $i \in \mathbb{Z}$ . We will also compute the pro-cluster algebra  $\mathcal{A}((\mathcal{A}(\mathcal{T}_m^{zz}), z_{m,n}))$ . We keep in mind that it might often be useful to see  $(\mathbb{Z}_{>0} \cup \{\pm\infty\}, \leq)$  as the unit disk with countably many marked points on its boundary, which converge to the limit marked points  $\pm\infty$  in both clockwise and anticlockwise direction and where there are no marked points between the marked points  $-\infty$  and  $+\infty$  in a clockwise direction. See [7] for more details and see Figure 12 for an example of a certain zig-zag triangulation of  $(\mathbb{Z} \cup \{\pm\infty\}, \leq)$  pictured as the two-dimensional disk. This gives us another example of an infinite marked surface, and we will sometimes refer to  $(\mathbb{Z}_{>0} \cup \{\pm\infty\}, \leq)$  as  *$\infty$ -gon with two one-sided accumulation points*, for the reasons that we set out above. Without further ado, let us dive into the matters.

In this section  $m^- := -\lfloor \frac{m}{2} \rfloor$  and  $m^+ := \lfloor \frac{m-1}{2} \rfloor$ . Let  $\mathcal{P}_m$  be a disk with  $m$  marked points on its boundary that this time we label cyclically anticlockwise with integers  $m^-$  to  $m^+$ . Consider the family  $\{\Sigma_{\mathcal{T}_m^{zz}} \mid m \geq 3\}$  of seeds associated with the zig-zag triangulation of  $\mathcal{P}_m$  (see page 98 for explicit description of  $\mathcal{T}_m^{zz}$  and some concrete examples in Figure 7). Recall

(see Example 5.47) that the map  $z_{m,n} : \mathcal{A}(\mathcal{T}_m^{zz}) \rightarrow \mathcal{A}(\mathcal{T}_n^{zz})$  is given by the algebraic extension of

$$x_{ij} \mapsto \begin{cases} x_{ij}, & n^- \leq i < j \leq n^+ \\ x_{in^+}, & n^- \leq i < n^+ \leq j \leq m^+ \\ x_{n^-j}, & m^- \leq i \leq n^- < j \leq n^+ \\ x_{n^-n^+}, & m^- \leq i \leq n^- < n^+ \leq j \leq m^+ \\ 0, & m^- \leq i < j \leq n^- \text{ or } n^+ \leq i < j \leq m^+. \end{cases}$$

Recall that  $z_{m,m-1} = \tilde{f}_{m,m-1}$  if  $m$  is odd and that  $z_{m,m-1} = \tilde{g}_{m,m-1}$  if  $m$  is even. In Figure 12 below we show how the map  $z_{m,n}$  acts on certain triangulations (of a convex polygon). Throughout the rest of this section we denote by:

- $\bar{C}$  the inverse system  $(\mathcal{A}(\mathcal{T}_m^{zz}), z_{m,n})$  in the category **fClus**
- $(R_{\bar{C}}, z_m)$  its limit in **Ring**.

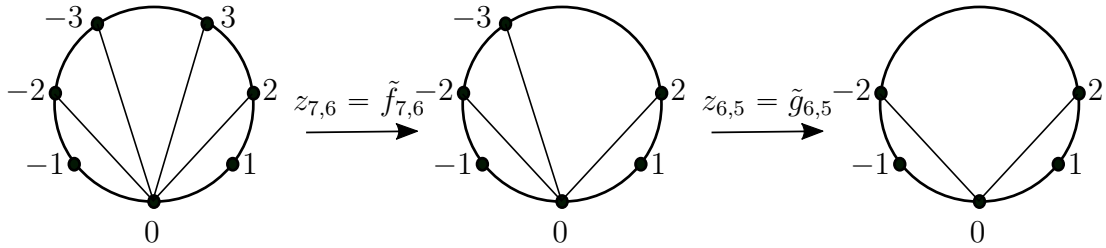

Figure 12: The action of the freezing morphism  $z_{m,n}$  on the fountain triangulation at 0 of a 7-gon and of a 6-gon.

**Remark 6.26.** This section and the next section will follow essentially the same logical path as the previous one, with almost every statement in 6.4 having its counterpart in 6.3 and with their proofs being similar in nature to those seen in section 6.3. Where unambiguous, we will refer to the relevant proofs from 6.3 for brevity.

**Proposition 6.27.** *Let  $\mathcal{T}'_m$  be a triangulation of  $\mathcal{P}_m$  and let  $X_{\mathcal{T}'_m}$  be the corresponding cluster in  $\mathcal{A}(\Sigma_{\mathcal{T}'_m})$ . Then  $z_{m,n}(X_{\mathcal{T}'_m}) \setminus \{0\}$  is a cluster in  $\mathcal{A}(\Sigma_{\mathcal{T}_n^{zz}})$ , for all  $n < m$ .*

*Proof.* Let  $J := (\{m^-, \dots, m^+\}, \leq)$ ,  $J_n := (\{n^-, \dots, n^+\}, \leq)$  be linearly ordered sets with  $\leq$  the usual less or equal to relation. Regarding  $\mathcal{T}'_m$  as a triangulation of  $J$ , we have that  $t_{(J, \mathcal{T}'_m) \rightarrow J_n}$  (making use of the notation introduced in Section 6.2) is a triangulation of  $J_n$  by Corollary 6.11, or equivalently, of  $\mathcal{P}_n$ . But then using the definition of  $z_{m,n}$  we have that  $z_{m,n}(X_{\mathcal{T}'_m}) \setminus \{0\} = \{x_{ij} \mid (i, j) \in t_{(J, \mathcal{T}'_m) \rightarrow J_n}\}$ . Thus  $z_{m,n}(X_{\mathcal{T}'_m}) \setminus \{0\}$  corresponds to a triangulation of  $\mathcal{P}_n$  and so it is a cluster, as required.  $\square$

The same as in the previous section, we will only consider complete  $\overline{C}$ -admissible sequences and their associated pro-clusters.

**Example 6.28.** Let  $\underline{X} = (X_{\mathcal{T}_m^{zz}})_{m \geq 3}$ . Then  $z_{m,n}(X_{\mathcal{T}_m^{zz}}) = X_{\mathcal{T}_n^{zz}} \cup \{0\}$  for all  $m \geq n \geq 3$  and so  $\underline{X}$  is  $\overline{C}$ -complete.

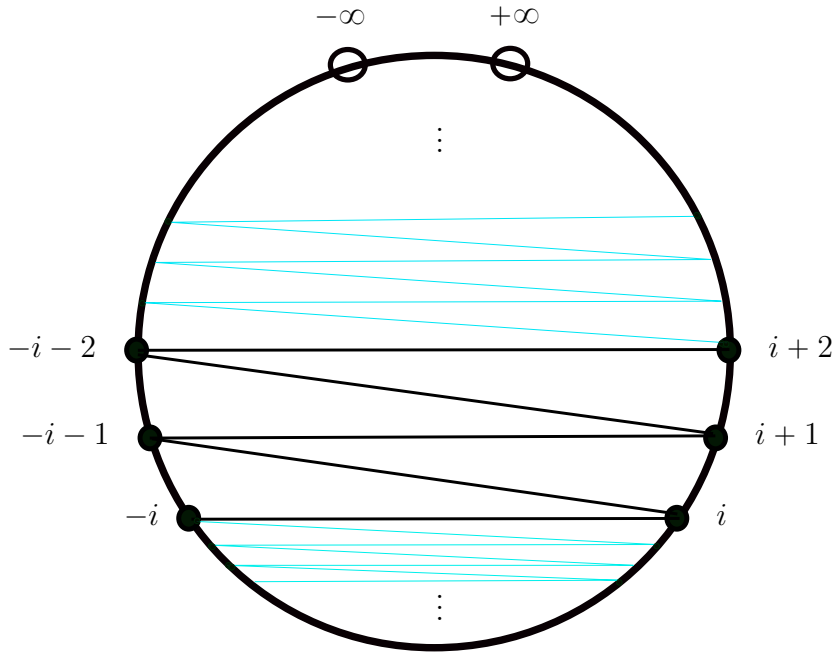

Figure 13: The zig-zag triangulation corresponding to the pro-cluster  $X((X_{\mathcal{T}_m^{zz}})_{m \geq 3})$ , where we regard  $(\mathbb{Z} \cup \{\pm\infty\}, \leq)$  as an  $\infty$ -gon with two one-sided accumulation points  $+\infty$  and  $-\infty$ , which we represent with open circles.

**Example 6.29.** For every  $m \geq 3$  denote by  $\mathcal{T}_m$  the triangulation of  $\mathcal{P}_m$  with its diagonals given by the set  $\{(m^-, i) \mid m^- + 1 < i \leq 0\} \cup \{(i, m^+) \mid 0 \leq i < m^+ - 1\}$  and let  $\underline{X} = (X_{\mathcal{T}_m})_{m \geq 3}$ .

Then  $z_{m,n}(X_{\mathcal{T}_m}) = X_{\mathcal{T}_n} \cup \{0\}$  for all  $m \geq n \geq 3$  and so  $\underline{X}$  is  $\overline{C}$ -complete. In Figure 14 we show the triangulations corresponding to the clusters  $X_{\mathcal{T}_m}$  for  $m = 3, 4, 5, 6$ .

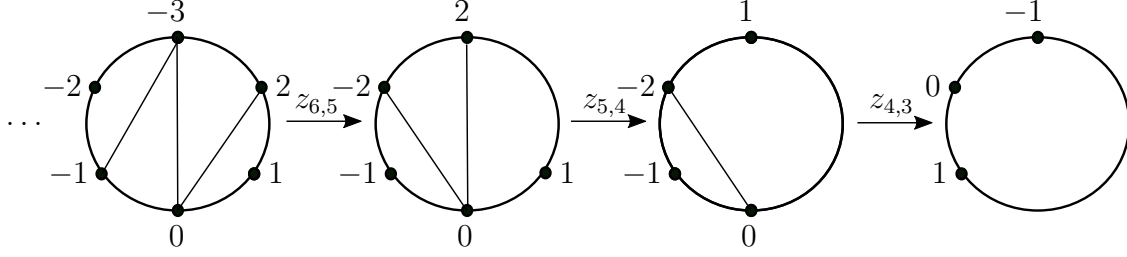

Figure 14: The tail of the  $\overline{C}$ -complete admissible sequence  $(X_{\mathcal{T}_m})_{m \geq 3}$ , where  $\mathcal{T}_m$  is the triangulation described in Example 6.29.

**Corollary 6.30.** *Recall that  $\underline{X}_{\overline{C}}$  is the set of all  $\overline{C}$ -admissible sequences and that  $\mathcal{X}(\underline{X}_{\overline{C}})$  is the set of all pro-clusters coming from all of the sequences in  $\underline{X}_{\overline{C}}$ . Then*

$$\mathcal{X}(\underline{X}_{\overline{C}}) = \{X(\underline{X}) \mid \underline{X} \in \underline{X}_{\overline{C}} \text{ is } \overline{C}\text{-complete}\}$$

.

*Proof.* The claim follows directly from Proposition 6.7 and Proposition 6.27.  $\square$

For  $-\infty < i < j < +\infty$  set  $\tilde{x}_{ij} \in R_{\overline{C}}$  to be the unique element of  $R_{\overline{C}}$  such that  $z_m(\tilde{x}_{ij}) = x_{ij}$  for all  $m$  such that  $m^- < i < j < m^+$ . Also, set  $\tilde{x}_{i+\infty} \in R_{\overline{C}}$  to be the unique element of  $R_{\overline{C}}$  such that  $z_m(\tilde{x}_{i+\infty}) = x_{im^+}$  for all  $m$  such that  $m^+ > |i|$  and set  $\tilde{x}_{-\infty i} \in R_{\overline{C}}$  to be the unique element of  $R_{\overline{C}}$  such that  $z_m(\tilde{x}_{-\infty i}) = x_{m^-i}$  for all  $m$  such that  $-m^- > |i|$ . Finally, set  $\tilde{x}_{-\infty+\infty} \in R_{\overline{C}}$  to be the unique element of  $R_{\overline{C}}$  such that  $z_m(\tilde{x}_{-\infty+\infty}) = x_{m^-m^+}$  for all  $m \geq 3$ .

**Lemma 6.31.** *Let  $\tilde{x}_{ij} \in R_{\overline{C}}$ . Then*

$$z_m(\tilde{x}_{ij}) = \begin{cases} x_{ij}, & m^- \leq i < j \leq m^+ \\ x_{im^+}, & m^- \leq i < m^+ \leq j \leq \infty \\ x_{m^-j}, & -\infty \leq i \leq m^- < j \leq m^+ \\ x_{m^-m^+}, & -\infty \leq i \leq m^- < m^+ \leq j \leq \infty \\ 0, & -\infty \leq i < j \leq m^- \text{ or } m^+ \leq i < j \leq \infty. \end{cases}$$

*Proof.* The procedure here is essentially the same as the one used in the proof of Lemma 6.16 and involves a simple case-by-case verification based on the subscripts  $i$  and  $j$ , making use of the corresponding description of an element  $\tilde{x}_{ij} \in R_{\overline{C}}$ , and the fact that  $(R_{\overline{C}}, z_m)$  is a cone.  $\square$

**Lemma 6.32.** *Let  $\underline{X} = (X_m)_{m \geq 3}$  be a complete  $\overline{C}$ -admissible sequence and let  $x \in X(\underline{X})$ . Then  $x = \tilde{x}_{ij}$  for some  $-\infty \leq i < j \leq +\infty$ .*

*Proof.* We have that  $z_n(x) \in X_n$  for some  $n \geq 3$  or  $z_n(x) \in \mathbb{Z}$  for all  $n \geq 3$ . If  $z_n(x) \in \mathbb{Z}$  for all  $n \geq 3$  then  $x \in \mathbb{Z}$ , a contradiction.

Let us assume now that  $z_n(x) \in X_n$  for some  $n \geq 3$ . If  $z_m(x) \in \mathbb{Z}$  for some  $m > n$ , then  $z_n(x) = z_{m,n}(z_m(x)) \in \mathbb{Z}$ , a contradiction. Thus  $z_m(x) \in X_m$  for all  $m > n$ . Now since  $z_n(x) \in X_n$ , it follows that  $z_n(x) = x_{ij} \in X_n$  for some  $n^- \leq i < j \leq n^+$ .

Suppose first that  $n^- < i < j < n^+$ . Then  $z_m(x) = x_{ij}$  for all  $m > n$ . If  $l < n$  is such that  $l^- < i < j < l^+$  then  $z_{n,l}(z_n(x)) = z_{n,l}(x_{ij}) = x_{ij} = z_l(x)$ . Thus  $z_m(x) = x_{ij}$  for all  $m$  such that  $m^- < i < j < m^+$  and we have by uniqueness of  $\tilde{x}_{ij}$  that  $x = \tilde{x}_{ij}$ .

Next, suppose that  $z_n(x) = x_{in^+}$  for some  $n^- < i$ . For  $m > n$  we have that  $z_m(x) \in X_m$  and that  $z_{m,n}(z_m(x)) = z_n(x) = x_{in^+}$ . Thus either  $z_m(x) = x_{im^+}$  for all  $m \geq n$  or there exists  $l \geq n$  such that  $z_m(x) = x_{il^+}$  for all  $m > l$ . If the former is true and if there exists  $k < n$  such that  $k^+ > |i|$  then  $z_{n,k}(z_n(x)) = z_{n,k}(x_{in^+}) = x_{ik^+}$  by definition of  $z_{m,n}$  and the fact that  $-k^- \geq k^+$ . Thus  $z_m(x) = x_{im^+}$  for all  $m$  such that  $m^+ > |i|$  and by uniqueness of  $\tilde{x}_{i\infty}$ , we have that  $x = \tilde{x}_{i\infty}$ . Else, if the latter is true, then  $x = \tilde{x}_{il^+}$  by uniqueness of  $\tilde{x}_{il^+}$ . The case where  $z_n(x) = x_{n^-i}$  is dealt with analogously.

For the last case, suppose that  $z_n(x) = x_{n^-n^+}$ . Then without loss of generality we can assume that  $z_m(x) = x_{m^-m^+}$  for all  $m > n$ . It is enough to consider here only this particular case since all other possible cases would boil down to one of the cases already considered in this proof. Now since for  $l < n$  we have that  $z_{n,l}(z_n(x)) = z_{n,l}(x_{n^-n^+}) = x_{l^-l^+} = z_l(x)$ , it follows that  $z_m(x) = x_{m^-m^+}$  for all  $m \geq 3$  and so  $x = \tilde{x}_{-\infty+\infty}$ , by the uniqueness of  $\tilde{x}_{-\infty+\infty}$ .  $\square$

By using Corollary 6.30 and Lemma 6.32 we deduce that every pro-cluster arising from a  $\overline{C}$ -admissible sequence consists of the elements of the form  $\tilde{x}_{ij} \in R_{\overline{C}}$ , for some  $-\infty \leq i <$

$j \leq +\infty$ .

**Corollary 6.33.** *Let  $\underline{X} = (X_m)_{m \geq 3}$  be a  $\overline{C}$ -admissible sequence and let  $x \in X(\underline{X})$ . Then  $x = \tilde{x}_{ij}$  for some  $-\infty \leq i < j \leq +\infty$ .*

In view of the Corollary 6.33 above we will from now on denote an element of a pro-cluster  $X(\underline{X})$ , for any  $\overline{C}$ -admissible sequence  $\underline{X}$ , simply by  $\tilde{x}_{ij}$ , without further explanation.

We will now consider a linearly ordered set  $(\mathbb{Z} \cup \{\pm\infty\}, \leq)$  where  $\leq$  is the usual less or equal to relation and with the convention that  $-\infty < i < +\infty$  for all  $i \in \mathbb{Z}$ . The reason for this is that the pro-clusters arising from complete  $\overline{C}$ -admissible sequences will coincide with triangulations of  $(\mathbb{Z} \cup \{\pm\infty\}, \leq)$ . We note that for any triangulation  $T$  of  $(\mathbb{Z} \cup \{\pm\infty\}, \leq)$  we have that the arc  $(-\infty, +\infty)$  is in  $T$  as no arc of  $(\mathbb{Z} \cup \{\pm\infty\}, \leq)$  crosses  $(-\infty, +\infty)$ .

Our next result shows that every triangulation of  $(\mathbb{Z} \cup \{\pm\infty\}, \leq)$  gives rise to a pro-cluster.

**Lemma 6.34.** *Let  $T$  be a triangulation of  $(\mathbb{Z} \cup \{\pm\infty\}, \leq)$ . Then  $X_T := \{\tilde{x}_{ij} \mid (i, j) \in T\} \in \mathcal{X}(\underline{X}_{\overline{C}})$ .*

*Proof.* Throughout this proof  $J_n$  denotes a linearly ordered set  $(\{n^-, \dots, n^+\}, \leq)$  for any  $n \geq 3$ , with  $\leq$  being the less or equal to relation. Moreover, we let

$$T_n = \{(i, j) \in T \mid n^- \leq i < j \leq n^+\} \cup \{(j, n^-) \mid (i, j) \in T \text{ such that } -\infty \leq i < n^- < j < n^+\} \\ \cup \{(i, n^+) \mid (i, j) \in T \text{ such that } n^- < i < n^+ < j \leq +\infty\} \cup \{(n^-, n^+)\}.$$

We will show that the sequence  $\underline{X} := (X_{T_n})_{n \geq 3}$  is  $\overline{C}$ -complete, where we regard  $T_n$  as a triangulation of  $\mathcal{P}_n$ , and that  $X(\underline{X}) = X_T$ .

First, we have by Proposition 6.10 that  $T_n$  is a triangulation of  $J_n$ , or equivalently of  $\mathcal{P}_n$  for all  $n \geq 3$ . Moreover, using Proposition 6.10 together with Lemma 6.31 gives that  $X_{T_n} = z_n(X_T) \setminus \mathbb{Z}$  for all  $n \geq 3$ . To show that  $\underline{X}$  is  $\overline{C}$ -complete we have to show that  $z_{m,n}(X_{T_m}) \subseteq X_{T_n} \cup \mathbb{Z}$  for all  $m \geq n \geq 3$ . We have that for all  $m \geq n \geq 3$

$$z_{m,n}(X_{T_m}) = z_{m,n}(z_m(X_T) \setminus \mathbb{Z}) \subseteq z_{m,n}(z_m(X_T)) = z_n(X_T) \subseteq X_{T_n} \cup \mathbb{Z}$$

and so  $\underline{X}$  is  $\overline{C}$ -complete, as required.



To conclude the claim it is now left to show that  $X(\underline{X}) = X_T$ . First, let  $\tilde{x}_{ij} \in X(\underline{X})$  be such that  $-\infty < i < j < +\infty$ . Then  $z_n(\tilde{x}_{ij}) = x_{ij} \in X_{T_n}$  for all  $n \geq 3$  such that  $n^- < i < j < n^+$  and so  $(i, j) \in T_n$  for all such  $n$ . But then, by construction of  $T_n$ , we have that  $(i, j) \in T$  and so  $\tilde{x}_{ij} \in X_T$ . Now, suppose that  $-\infty < i < j = +\infty$ . Then  $z_n(\tilde{x}_{i+\infty}) = x_{in^+} \in X_{T_n}$  for all  $n$  such that  $n^+ > |i|$  and so  $(i, n^+) \in T_n$  for all such  $n$ . Then, by construction of  $T_n$  and Lemma 6.9 we deduce that  $(i, +\infty) \in T$  and so  $\tilde{x}_{i+\infty} \in X_T$ . By symmetry, if  $i = -\infty < j < +\infty$  then  $\tilde{x}_{-\infty j} \in X_T$ . Finally, the case where  $i = -\infty$  and  $j = +\infty$  follows from the fact that the arc  $(-\infty, +\infty)$  is in every triangulation of  $(\mathbb{Z} \cup \{\pm\infty\}, \leq)$ .

On the other hand, let  $\tilde{x}_{ij} \in X_T$ . Then  $(i, j) \in T$  and so if  $-\infty < i < j < +\infty$  we have that  $(i, j) \in T_n$  for all  $n \geq 3$  such that  $n^- < i < j < n^+$  and so  $z_n(\tilde{x}_{ij}) \in X_{T_n}$  for all such  $n$ . Else, if  $-\infty < i < j = +\infty$  then as  $(i, +\infty) \in T$  we have that  $(i, n^+) \in T_n$  for all  $n \geq 3$  such that  $n^+ > |i|$  and so  $z_n(\tilde{x}_{i+\infty}) = x_{in^+} \in X_{T_n}$  for all such  $n$ . Similarly, if  $-\infty = i < j < +\infty$  then as  $(-\infty, j) \in T$  we have that  $(n^-, j) \in T_n$  for all  $n \geq 3$  such that  $-n^- > j$  and so  $z_n(\tilde{x}_{-\infty j}) = x_{n^- j} \in X_{T_n}$  for all such  $n$ . But then we have in all three cases that since  $\underline{X}$  is a complete  $\overline{C}$ -admissible sequence and since  $\tilde{x}_{ij} \in R_{\overline{C}}$  it follows that  $z_{m,n}(z_m(\tilde{x}_{ij})) = z_n(\tilde{x}_{ij}) \in X_{T_n} \cup \{0\}$  for all  $m \geq n \geq 3$ . Therefore, if  $\tilde{x}_{ij} \in X_T$  then  $\tilde{x}_{ij} \in X(\underline{X})$  and so  $X_T \subseteq X(\underline{X})$ .

We deduce that  $X(\underline{X}) = X_T$ , as required.  $\square$

**Lemma 6.35.** *Let  $\underline{X} = (X_n)_{n \geq 3}$  be a complete  $\overline{C}$ -admissible sequence. Let  $T = \{(i, j) \mid \tilde{x}_{ij} \in X(\underline{X})\}$ . Then  $T$  is a triangulation of  $(\mathbb{Z} \cup \{\pm\infty\}, \leq)$ .*

*Proof.* Suppose there exists  $\tilde{x}_{ij} \in X(\underline{X})$  and  $\tilde{x}_{kl} \in X(\underline{X})$  such that  $(i, j)$  crosses  $(k, l)$ . Without loss of generality we will assume that  $i < k$ . Then  $-\infty \leq i < k < j < l \leq +\infty$ .

Assume first that  $-\infty = i < k < j < l = +\infty$ . Let  $n$  be such that  $n^- < k < j < n^+$ . Then  $z_n(\tilde{x}_{-\infty j}) = x_{n^- j} \in X_n$  and  $z_n(\tilde{x}_{k+\infty}) = x_{kn^+} \in X_n$ . But then  $(n^-, j)$  crosses  $(k, n^+)$  and we have that  $X_n$  is not a cluster, a contradiction.

Next, consider the case where  $-\infty < i < k < j < l < +\infty$ . Let  $n$  be such that  $n^- < i < k < j < l < n^+$ . Then  $z_n(\tilde{x}_{ij}) = x_{ij} \in X_n$  and  $z_n(\tilde{x}_{kl}) = x_{kl} \in X_n$  and since  $(i, j)$  crosses  $(k, l)$  it follows that  $X_n$  is not a cluster, a contradiction.

Now, consider the case where  $-\infty < i < k < j < l = +\infty$ . Let  $n$  be such that  $n^- < i < j < n^+$ . Then  $z_n(\tilde{x}_{ij}) = x_{ij} \in X_n$  and  $z_n(\tilde{x}_{k+\infty}) = x_{kn^+} \in X_n$ . But then  $i < k < j < n^+$  and so  $(i, j)$  crosses  $(k, n^+)$  which implies that  $X_n$  is not a cluster, giving us yet another contradiction. The case where  $-\infty = i < k < j < l < +\infty$  is dealt with analogously. Therefore  $T$  consists of pairwise non-crossing arcs of  $(\mathbb{Z} \cup \{\pm\infty\}, \leq)$ .

To prove the claim we must now show that  $T$  is maximal. Suppose that there exists an arc  $(k, l)$  in  $(\mathbb{Z} \cup \{\pm\infty\}, \leq)$  such that  $\tilde{x}_{kl} \notin X(\underline{X})$  and such that  $(k, l)$  does not cross any of the arcs from  $T$ . Since  $\tilde{x}_{kl} \notin X(\underline{X})$ , there exists  $m \geq 3$  for which  $\tilde{x}_{kl} \notin z_m^{-1}(X_m \cup \mathbb{Z})$ . Consider a  $\tilde{x}_{ij} \in X(\underline{X})$  such that  $\tilde{x}_{ij} \in z_m^{-1}(X_m)$ . We note that  $z_m(\tilde{x}_{kl})$  is a cluster variable which follows from the fact that  $z_m(\tilde{x}_{kl}) \notin \mathbb{Z}$  and Lemma 6.31. That is,  $z_m(\tilde{x}_{kl}) = x_{k'l'}$  for some  $m^- \leq k' < l' \leq m^+$ . Because  $\tilde{x}_{ij} \in z_m^{-1}(X_m)$  we have that  $z_m(\tilde{x}_{ij}) = x_{i'j'}$  for some  $m^- \leq i' < j' \leq m^+$ . Suppose that  $(k', l')$  crosses  $(i', j')$  in  $\mathcal{P}_m$ . Then either  $m^- \leq i' < k' < j' < l' \leq m^+$  or  $m^- \leq k' < i' < l' < j' \leq m^+$ . We will only consider the former case as the latter case is dealt with analogously. If  $m^- < i' < k' < j' < l' < m^+$  then  $(k, l) = (k', l')$  and  $(i, j) = (i', j')$ , by Lemma 6.31, and so  $(k, l)$  crosses  $(i, j) \in T$ , contradicting the assumption that  $(k, l)$  crosses no arcs from  $T$ .

Else, if  $m^- = i' < k' < j' < l' = m^+$  then  $(k, l) = (k', l')$  and  $(i, j) = (i', j')$  and as  $m^+ \leq l \leq +\infty$  and  $-\infty \leq j \leq m^-$  which is due to Lemma 6.31, we have that  $(k, l)$  crosses  $(i, j) \in T$ , another contradiction. Next, if  $m^- < i' < k' < j' < l' = m^+$  then  $(k, l) = (k', l')$  for some  $m^+ \leq l \leq +\infty$  and  $(i, j) = (i', j')$  by Lemma 6.31. This implies that  $i < k < j < l$  and so  $(k, l)$  crosses  $(i, j) \in T$ , giving us yet another contradiction. The case where  $m^- = i' < k' < j' < l' < m^+$  is dealt with analogously and so we skip the details. Putting everything together we have that  $z_m(\tilde{x}_{kl})$  and  $z_m(\tilde{x}_{ij})$  do not cross in  $\mathcal{P}_m$ . But then since  $\tilde{x}_{kl} \notin z_m^{-1}(X_m)$ , we have that the triangulation corresponding to  $X_m$  is not maximal and so  $X_m$  is not a cluster, a contradiction.

We conclude that  $T$  is a triangulation of  $(\mathbb{Z} \cup \{\pm\infty\}, \leq)$ , as required.  $\square$

Recall (cf. page 105) that the set of all pro-cluster arising from  $\overline{C}$  is denoted by  $\mathcal{X}(\underline{X}_{\overline{C}})$ .

**Theorem 6.36.** *The set  $\mathcal{X}(\underline{X}_{\overline{C}})$  is the set*

$$\left\{ X_T \mid T \text{ is a triangulation of } (\mathbb{Z} \cup \{\pm\infty\}, \leq) \right\},$$

where  $X_T = \{\tilde{x}_{ij} \in R_{\overline{C}} \mid (i, j) \in T\}$  for any triangulation  $T$  of  $(\mathbb{Z} \cup \{\pm\infty, \}, \leq)$ .

*Proof.* We have by Corollary 6.30 that  $\mathcal{X}(\underline{X}_{\overline{C}}) = \{X(\underline{X}) \mid \underline{X} \text{ is } \overline{C}\text{-complete}\}$ . Then by Lemma 6.35 we have that

$$\mathcal{X}(\underline{X}_{\overline{C}}) \subseteq \left\{ X_T \mid T \text{ is a triangulation of } (\mathbb{Z} \cup \{\pm\infty, \}, \leq) \right\}.$$

Moreover,

$$\left\{ X_T \mid T \text{ is a triangulation of } (\mathbb{Z} \cup \{\pm\infty, \}, \leq) \right\} \subseteq \mathcal{X}(\underline{X}_{\overline{C}}),$$

by Lemma 6.34, and so

$$\mathcal{X}(\underline{X}_{\overline{C}}) = \left\{ X_T \mid T \text{ is a triangulation of } \mathcal{P}_\infty \right\},$$

as required. □

**Example 6.37.** Denote by  $\mathcal{T}_m$  the triangulation of  $\mathcal{P}_m$  with its diagonals given by the set  $\{(m^-, i) \mid m^- + 1 < i \leq 0\} \cup \{(i, m^+) \mid 0 \leq i < m^+ - 1\}$ . Then the  $\overline{C}$ -admissible sequence  $\underline{X} = (X_{\mathcal{T}_m})_{m \geq 3}$  yields the pro-cluster

$$X(\underline{X}) = \{\tilde{x}_{ii+1} \mid i \in \mathbb{Z}\} \cup \{\tilde{x}_{-\infty i} \mid i \in \mathbb{Z}_{\leq 0}\} \cup \{\tilde{x}_{i+\infty} \mid i \in \mathbb{Z}_{\geq 0}\} \cup \{x_{-\infty+\infty}\}.$$

Moreover, the set  $T$  of arcs of  $(\mathbb{Z} \cup \{\pm\infty, \}, \leq)$  given by  $T = \{(i, j) \mid \tilde{x}_{ij} \in X(\underline{X})\}$  is a triangulation of  $(\mathbb{Z} \cup \{\pm\infty, \}, \leq)$ . See Figure 15, where we regard  $(\mathbb{Z} \cup \{+\infty, \}, \leq)$  as a two-dimensional disk with infinitely many marked points and two one-sided marked accumulation points  $+\infty$  and  $-\infty$ , which we represent with open circles.

The definition of a pro-cluster algebra together with Theorem 6.36 above immediately imply the following.

**Corollary 6.38.** *The pro-cluster algebra  $\mathcal{A}(\overline{C})$  is the subring of  $R_{\overline{C}}$  generated by the set*

$$\{\tilde{x}_{ij} \mid -\infty \leq i < j \leq +\infty\}.$$

As we will see in Theorem 6.39 below, the generators of  $\mathcal{A}(\overline{C})$  satisfy *extended* Plücker relations (see page 53).

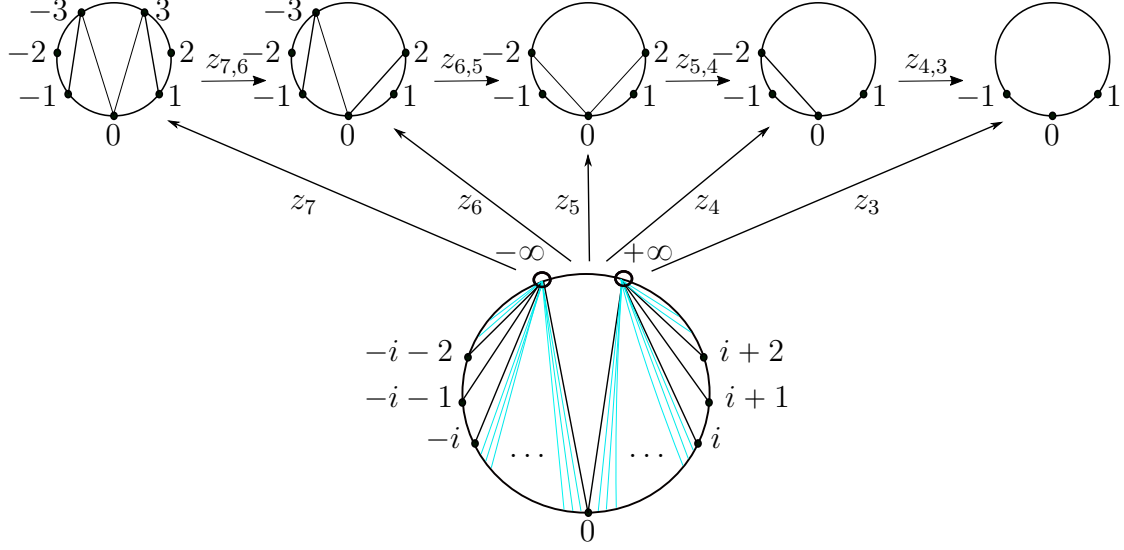

Figure 15: The tail of the  $\overline{C}$ -complete admissible sequence  $\underline{X} = (X_{\mathcal{T}_m})_{m \geq 3}$ , with  $\mathcal{T}_m$  as described in Example 6.37, and the triangulation of  $(\mathbb{Z} \cup \{\pm\infty\}, \leq)$  corresponding to the pro-cluster  $X(\underline{X})$

**Theorem 6.39.** *The pro-cluster algebra  $\mathcal{A}(\overline{C})$  is the ring*

$$\frac{\mathbb{Z}[x_{ij} \mid -\infty \leq i < j \leq +\infty]}{(x_{ij}x_{kl} - x_{ik}x_{jl} - x_{kj}x_{il} \text{ for } -\infty \leq i < k < j < l \leq +\infty)}.$$

*Proof.* Let  $S = \mathbb{Z}[x_{ij} \mid -\infty \leq i < j \leq +\infty]$ . For simplicity, we will denote  $(\mathbb{Z} \cup \pm\infty, \leq)$  by  $\mathcal{P}_{\pm\infty}$  throughout this proof. We denote by  $\alpha$  an element of the set  $\mathbb{N}_0^{\mathcal{P}_{\pm\infty} \times \mathcal{P}_{\pm\infty}}$  with finite support and such that  $\alpha(i, j) = 0$  whenever  $i \geq j$  and by  $x^\alpha$  the corresponding monomial in  $S$ . For  $(i, j) \in \mathcal{P}_{\pm\infty} \times \mathcal{P}_{\pm\infty}$  we let

$$|(i, j)| = \begin{cases} \max\{|i|, |j|\}, & -\infty < i < j < +\infty \\ |i|, & -\infty < i < j = +\infty \\ |j|, & -\infty = i < j < +\infty \\ 0, & \text{else} \end{cases}$$

and let  $\|\alpha\| := \max\{|(i, j)| : \alpha(i, j) > 0\}$ .

By universal property of polynomial rings there exists a unique ring homomorphism  $\phi : S \rightarrow \mathcal{A}(\overline{C})$  such that  $\phi(x_{ij}) = \tilde{x}_{ij}$  for all  $-\infty \leq i < j \leq +\infty$ . Since the elements  $\tilde{x}_{ij}$

generate  $\mathcal{A}(\overline{C})$  it follows that  $\phi$  is surjective. Thus  $\mathcal{A}(\overline{C}) = S/I$  for some ideal  $I$  of  $S$ . We claim that  $I = P$ , where  $P := (x_{ij}x_{kl} - x_{ik}x_{jl} - x_{kj}x_{il} \text{ for } -\infty \leq i < k < j < l \leq +\infty) \subseteq S$ . First, let  $x \in P$ . That is,

$$x = \sum_{-\infty \leq i < k < j < l \leq +\infty} f_{ikjl}(x_{ij}x_{kl} - x_{ik}x_{jl} - x_{kj}x_{il}) \in S$$

where  $f_{ikjl} \in S$  and with  $f_{ikjl} = 0$  for all but finitely many  $(i, k, j, l) \in \mathcal{P}_{\pm\infty}^4$  such that  $-\infty \leq i < k < j < l \leq +\infty$ . Pick  $m \geq 3$  such that  $m^- < a < m^+$  for all

$$a \in \bigcup_{f_{ikjl} \neq 0} \{i, k, j, l\} \cap \mathbb{Z}.$$

Then  $z_n(\phi(x)) = 0$  for all  $n \geq m$  by Lemma 6.31 and the fact that

$$\mathcal{A}(\Sigma_{\mathcal{T}_m^{zz}}) = \frac{\mathbb{Z}[x_{ij} | m^- - 1 \leq i < j \leq m^+]}{(x_{ik}x_{jl} = x_{ij}x_{kl} + x_{jk}x_{il} \text{ for } m^- \leq i < j < k < l \leq m^+)}.$$

In fact, since  $(R_{\overline{C}}, z_n)$  is a cone, it follows that  $z_n(\phi(x)) = 0$  for all  $n \geq 3$  and so  $\phi(x) = 0$ . Thus  $x \in I$ .

On the other hand we have

$$S \longrightarrow S/I = \mathcal{A}(\overline{C}) \hookrightarrow R_{\overline{C}} \longrightarrow \mathcal{A}(\Sigma_{\mathcal{T}_n}),$$

where the first map is the projection, the second map is the embedding and the last map is the map  $g_n$ . We denote by  $\tilde{z}_n$  the composite of these three maps. We have that  $\tilde{z}_n(x_{ij}) = z_n(\tilde{x}_{ij})$  for all  $-\infty \leq i < j \leq +\infty$  and for all  $n \geq 3$ . Now  $r = \sum a_\alpha x^\alpha \in I$  is a linear combination of monomials  $x^\alpha$  with all but finitely many integral coefficients  $a_\alpha$  equal to zero. Let  $m \in \mathbb{Z}_{\geq 3}$  be such that for every monomial  $x^\alpha$  with non-zero coefficient (in  $r$ ) we have that  $m^- < -\|\alpha\|$  and  $m^+ > \|\alpha\|$ . Such  $m$  is guaranteed to exist as all but finitely many coefficients in  $r$  are equal to zero. Assume that  $r \notin P$ . But then we have that  $\tilde{z}_m(x_{ij}) = z_m(\tilde{x}_{ij})$  for all  $-\infty \leq i < j \leq +\infty$  which together with Lemma 6.31 implies that

$$\mathcal{A}(\Sigma_{\mathcal{T}_m}) \neq \frac{\mathbb{Z}[x_{ij} | m^- \leq i < j \leq m^+]}{(x_{ik}x_{jl} = x_{ij}x_{kl} + x_{jk}x_{il} \text{ for } m^- \leq i < j < k < l \leq m^+)},$$

giving us a contradiction. Thus we have that  $r \in P$  and so  $I = P$ , as required.  $\square$

### 6.4.2 One two-sided limit point pro-cluster algebra

So far in this chapter, we have seen pro-cluster algebras that were, colloquially speaking, generated by

- the arcs of a disk with infinitely many marked points and a single one-sided marked accumulation point (Section 6.3);
- the arcs of a disk with infinitely many marked points and two one-sided marked accumulation points (Section 6.4.1).

The aim of this section, which will have a very similar structure to that of sections 6.4.1 and 6.3, will be to construct a pro-cluster algebra that is generated by the arcs of a disk with infinitely many marked points and one two-sided marked accumulation point.

Throughout this section  $m^-, m^+, \mathcal{P}_m, \mathcal{T}_m^{zz}$  are defined in the same way as previously in 6.4.1. This time we will consider the inverse system  $(\mathcal{A}(\mathcal{T}_m^{zz}), \tilde{f}_{m,n})$  where  $\tilde{f}_{m,n} : \mathcal{A}(\mathcal{T}_m^{zz}) \rightarrow \mathcal{A}(\mathcal{T}_n^{zz})$  is the freezing rooted cluster morphism defined to be the algebraic extension of

$$x_{ij} \mapsto \begin{cases} x_{ij}, & n^- \leq i < j \leq n^+, \\ x_{in^+}, & n^- \leq i < n^+ < j \leq m^+, \\ x_{jn^+}, & m^- \leq i < n^- \leq j < n^+, \\ 0, & \text{else.} \end{cases} \quad (14)$$

We will show that the pro-clusters arising from  $(\mathcal{A}(\mathcal{T}_m^{zz}), \tilde{f}_{m,n})$  coincide with triangulations of the linearly ordered set  $(\mathbb{Z} \cup \{+\infty\}, \leq)$ , where  $\leq$  is the usual less or equal to relation with the convention that  $i < +\infty$  for every  $i \in \mathbb{Z}$ . The set  $(\mathbb{Z} \cup \{+\infty\}, \leq)$  can be regarded as the unit disk with countably infinitely many marked points on its boundary, which converge to the limit marked point  $+\infty$  in both clockwise and anticlockwise direction, giving us yet another example of infinite marked surface. In Figure 16 we show a certain zig-zag triangulation of  $(\mathbb{Z} \cup \{+\infty\}, \leq)$ , picturing  $(\mathbb{Z} \cup \{+\infty\}, \leq)$  as the two-dimensional disk. We will sometimes refer to  $(\mathbb{Z} \cup \{+\infty\}, \leq)$  as  *$\infty$ -gon with one two-sided accumulation point*.

Throughout the rest of this section we denote by:

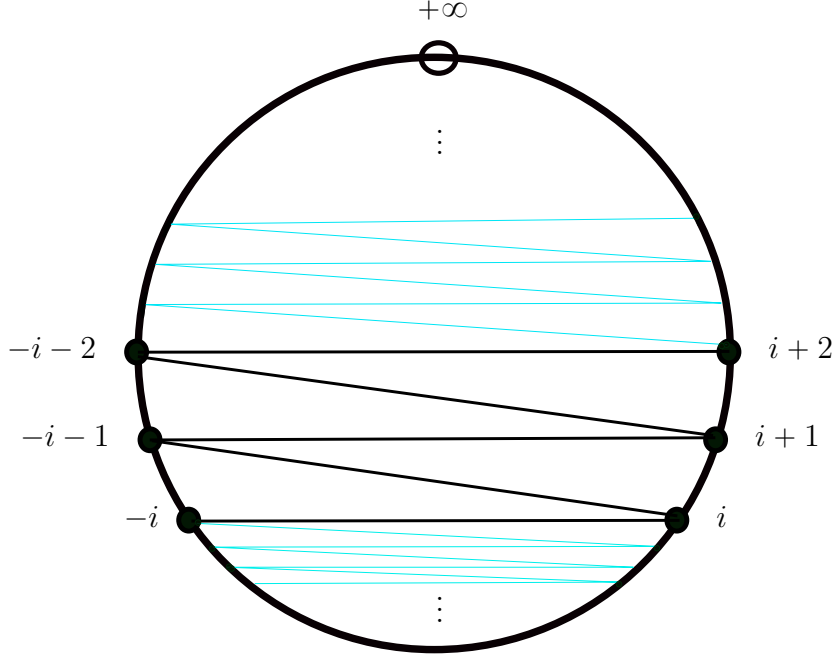

Figure 16: The zig-zag triangulation corresponding to the pro-cluster  $X((X_{\mathcal{T}_m^{zz}})_{m \geq 3})$ , where we regard  $(\mathbb{Z} \cup \{+\infty\}, \leq)$  as  $\infty$ -gon with one two-sided accumulation point  $+\infty$  that we mark with an open circle.

- $\hat{C}$  the inverse system  $(\mathcal{A}(\mathcal{T}_m^{zz}), \tilde{f}_{m,n})$  in the category **fClus**
- $(R_{\hat{C}}, \tilde{f}_m)$  its limit in **Ring**.

As in the previous sections, we will first show that it is enough to consider pro-clusters that arise from  $\hat{C}$ -complete sequences. We start with the following proposition.

**Proposition 6.40.** *Let  $\mathcal{T}'_m$  be a triangulation of  $\mathcal{P}_m$  and let  $X_{\mathcal{T}'_m}$  be the corresponding cluster in  $\mathcal{A}(\Sigma_{\mathcal{T}_m^{zz}})$ . Then  $\tilde{f}_{m,n}(X_{\mathcal{T}'_m}) \setminus \{0\}$  is a cluster in  $\mathcal{A}(\Sigma_{\mathcal{T}_n^{zz}})$ , for all  $n < m$ .*

*Proof.* Let  $J := (\{m^-, \dots, m^+\}, \leq)$ ,  $J_n := (\{n^-, \dots, n^+\}, \leq)$  be linearly ordered sets with  $\leq$  the usual less or equal to relation. Regarding  $\mathcal{T}'_m$  as a triangulation of  $J$ , we have that  $t_{(J, \mathcal{T}'_m) \rightarrow J_n}^{0,1}$  (again making use of the notation from the beginning of section 6.2) is a triangulation of  $J_n$  by Corollary 6.11, or equivalently, of  $\mathcal{P}_n$ . By then using the definition (see (14)) of  $\tilde{f}_{m,n}$  we have that  $\tilde{f}_{m,n}(X_{\mathcal{T}'_m}) \setminus \{0\} = \{x_{ij} \mid (i, j) \in t_{(J, \mathcal{T}'_m) \rightarrow J_n}^{0,1}\}$ . Thus  $\tilde{f}_{m,n}(X_{\mathcal{T}'_m}) \setminus \{0\}$  corresponds to a triangulation of  $\mathcal{P}_n$  and so it is a cluster, as required.  $\square$

**Example 6.41.** For every  $m \geq 3$  denote by  $\mathcal{T}_m$  the fountain triangulation at  $m^+$  and let  $\underline{X} = (X_{\mathcal{T}_m})_{m \geq 3}$ . Then  $\tilde{f}_{m,n}(X_{\mathcal{T}_m}) = X_{\mathcal{T}_n} \cup \{0\}$  for all  $m \geq n \geq 3$  and so  $\underline{X}$  is  $\widehat{C}$ -complete. In Figure 17 we show the triangulations corresponding to the clusters  $X_{\mathcal{T}_m}$  for  $m = 3, 4, 5, 6$ .

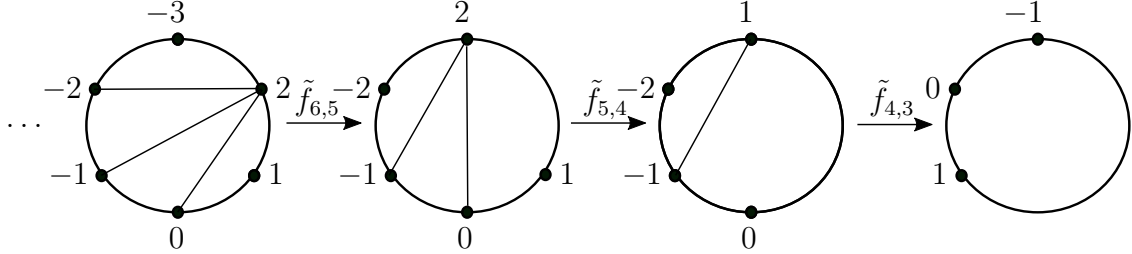

Figure 17: The tail of the  $\widehat{C}$ -complete admissible sequence  $(X_{\mathcal{T}_m})_{m \geq 3}$ , where  $\mathcal{T}_m$  is the fountain triangulation at  $m^+$  for every  $m \geq 3$ .

**Corollary 6.42.** Recall that the  $\underline{X}_{\widehat{C}}$  is the set of all  $\widehat{C}$ -admissible sequences and that  $\mathcal{X}(\underline{X}_{\widehat{C}})$  is the set of all pro-clusters coming from all sequences in  $\underline{X}_{\widehat{C}}$ . Then

$$\mathcal{X}(\underline{X}_{\widehat{C}}) = \{X(\underline{X}) \mid \underline{X} \in \underline{X}_{\widehat{C}} \text{ is } \widehat{C}\text{-complete}\}.$$

*Proof.* The claim follows from Proposition 6.7 and Proposition 6.40.  $\square$

Now, for  $-\infty < i < j < +\infty$  we set  $\tilde{x}_{ij} \in R_{\widehat{C}}$  to be the unique element of  $R_{\widehat{C}}$  such that  $\tilde{f}_m(\tilde{x}_{ij}) = x_{ij}$  for all  $m$  such that  $m^- < i < j < m^+$ . Also, we set  $\tilde{x}_{i+\infty} \in R_{\widehat{C}}$  to be the unique element of  $R_{\widehat{C}}$  such that  $\tilde{f}_m(\tilde{x}_{i+\infty}) = x_{im^+}$  for all  $m$  such that  $|i| < -m^-$ .

**Lemma 6.43.** Let  $\tilde{x}_{ij} \in R_{\widehat{C}}$ . Then

$$\tilde{f}_m(\tilde{x}_{ij}) = \begin{cases} x_{ij}, & m^- \leq i < j \leq m^+ \\ x_{im^+}, & m^- \leq i < m^+ \leq j \leq +\infty \\ x_{jm^+}, & i < m^- \leq j < m^+ \\ 0, & \text{else.} \end{cases}$$

*Proof.* Suppose first that  $i < j < +\infty$ . Let  $m$  be such that  $m^- < i < j < m^+$ . Assume first that  $n < m$  is such that  $n^- \leq i < n^+ < j < m^+$ . Then using the definition of  $\tilde{f}_{m,n}$ , the fact that  $(R_{\widehat{C}}, \tilde{f}_m)$  is a cone and that  $\tilde{x}_{ij} \in R_{\widehat{C}}$  we have that  $\tilde{f}_{m,n}(\tilde{f}_m(\tilde{x}_{ij})) = \tilde{f}_{m,n}(x_{ij}) = x_{in^+} = \tilde{f}_n(\tilde{x}_{ij})$ .



Now, let  $n < m$  be such that  $m^- < i < n^- \leq j < n^+$ . Then  $\tilde{f}_{m,n}(\tilde{f}_m(\tilde{x}_{ij})) = \tilde{f}_{m,n}(x_{ij}) = x_{jn^+} = \tilde{f}_n(\tilde{x}_{ij})$ . Next assume that  $n < m$  is such that  $m^- < i < j < n^-$  or  $n^+ \leq i < j < m^+$  or  $m^- < i < n^- < n^+ \leq j < m^+$ . Then  $\tilde{f}_{m,n}(\tilde{f}_m(\tilde{x}_{ij})) = \tilde{f}_{m,n}(x_{ij}) = 0 = \tilde{f}_n(\tilde{x}_{ij})$ . Thus we have that if  $\tilde{x}_{ij} \in R_{\hat{C}}$  is such that  $i < j < \infty$  then

$$\tilde{f}_m(\tilde{x}_{ij}) = \begin{cases} x_{ij}, & m^- \leq i < j \leq m^+ \\ x_{im^+}, & m^- \leq i < m^+ < j < +\infty \\ x_{jm^+}, & i < m^- \leq j < m^+ \\ 0, & \text{else.} \end{cases}$$

The case  $i < j = +\infty$  is dealt with in the same manner as the case  $i < j < +\infty$  above and so we skip the technical details for brevity.  $\square$

**Lemma 6.44.** *Let  $\underline{X} = (X_m)_{m \geq 3}$  be a complete  $\hat{C}$ -admissible sequence and let  $x \in X(\underline{X})$ . Then  $x = \tilde{x}_{ij}$  for some  $i, j \in (\mathbb{Z} \cup \{+\infty\}, \leq)$  such that  $i < j \leq +\infty$ .*

*Proof.* We have that  $\tilde{f}_n(x) \in X_n$  for some  $n \geq 3$  or  $\tilde{f}_n(x) \in \mathbb{Z}$  for all  $n \geq 3$ . If  $\tilde{f}_n(x) \in \mathbb{Z}$  for all  $n \geq 3$  then  $x \in \mathbb{Z}$ , a contradiction.

Let us assume now that  $\tilde{f}_n(x) \in X_n$  for some  $n \geq 3$ . If  $\tilde{f}_m(x) \in \mathbb{Z}$  for some  $m > n$ , then  $\tilde{f}_n(x) = \tilde{f}_{m,n}(\tilde{f}_m(x)) \in \mathbb{Z}$ , a contradiction. Thus  $\tilde{f}_m(x) \in X_m$  for all  $m > n$ . Now since  $\tilde{f}_n(x) \in X_n$ , it follows that  $\tilde{f}_n(x) = x_{ij} \in X_n$  for some  $n^- \leq i < j \leq n^+$ .

Suppose first that  $n^- < i < j < n^+$ . Suppose that  $\tilde{f}_m(x) \neq x_{ij}$  for some  $m > n$ . But then  $\tilde{f}_{m,n}(\tilde{f}_m(x)) \neq x_{ij} = \tilde{f}_n(x)$ , a contradiction. Thus  $\tilde{f}_m(x) = x_{ij}$  for all  $m > n$ . If  $l < n$  is such that  $l^- < i < j < l^+$  then  $\tilde{f}_{n,l}(\tilde{f}_n(x)) = \tilde{f}_{n,l}(x_{ij}) = x_{ij} = \tilde{f}_l(x)$ . Thus  $\tilde{f}_m(x) = x_{ij}$  for all  $m$  such that  $m^- < i < j < m^+$  and we have by uniqueness of  $\tilde{x}_{ij}$  that  $x = \tilde{x}_{ij}$ .

Now, suppose that  $\tilde{f}_n(x) = x_{n^-j}$ . We know that  $\tilde{f}_m(x) \in X_m$  for all  $m > n$  and using the definition of  $\tilde{f}_{m,n}$  we have that  $\tilde{f}_{n+2}(x) = x_{n^-j}$ . But  $(n+2)^- < n^- < j < (n+2)^+$  and we are at the case which we considered in the previous paragraph and we deduce that  $x = \tilde{x}_{n^-j}$  in this case.

Next, suppose that  $\tilde{f}_n(x) = x_{in^+}$ . For every  $m > n$  we have that  $\tilde{f}_m(x) \in X_m$  and that  $\tilde{f}_{m,n}(\tilde{f}_m(x)) = \tilde{f}_n(x) = x_{in^+}$ . There are three different possibilities. Either

1.  $\tilde{f}_m(x) = x_{im^+}$  for all  $m > n$  or

2.  $\tilde{f}_k(x) = x_{k-j}$  for some  $k > n$  or

3. there exists  $k > n$  such that  $\tilde{f}_m(x) = x_{ik+}$  for all  $m > k$ .

If 1. is true and if there exists  $k < n$  such that  $|i| < -k^-$  then  $\tilde{f}_{n,k}(\tilde{f}_n(x)) = \tilde{f}_{n,k}(x_{in+}) = x_{ik+}$  and so  $\tilde{f}_m(x) = x_{im+}$  for all  $m$  such that  $|i| < -m^-$  and by uniqueness of  $\tilde{x}_{i+\infty}$ , we have that  $x = \tilde{x}_{i+\infty}$ .

If 2. is true then we are back to one of the cases that we have already considered and we deduce  $x = x_{k-j}$  in this case. If 3. is true then  $x = \tilde{x}_{ik+}$  by uniqueness of  $\tilde{x}_{ik+}$ .

For the last case, suppose that  $\tilde{f}_n(x) = x_{n-n+}$ . If  $n$  is odd then either  $\tilde{f}_{n+1}(x) = x_{(n+1)-n-}$  or  $\tilde{f}_{n+1}(x) = x_{n-n+}$ , in both cases reducing the problem to one of the cases that we already considered. Else, if  $n$  is even, then either  $\tilde{f}_{n+1}(x) = x_{n-(n+1)+}$  or  $\tilde{f}_{n+1}(x) = x_{n-n+}$ . Again, in both cases this reduces the problem to one of the previous cases and we are done.  $\square$

Using Corollary 6.42 and Lemma 6.44 we deduce that every pro-cluster arising from a  $\hat{C}$ -admissible sequence consists of the elements of the form  $\tilde{x}_{ij} \in R_{\hat{C}}$ , for some  $i, j \in (\mathbb{Z} \cup \{+\infty\}, \leq)$  such that  $i < j \leq +\infty$ .

**Corollary 6.45.** *Let  $\underline{X} = (X_m)_{m \geq 3}$  be a  $\hat{C}$ -admissible sequence and let  $x \in X(\underline{X})$ . Then  $x = \tilde{x}_{ij}$  for some  $i, j \in (\mathbb{Z} \cup \{+\infty\}, \leq)$  such that  $i < j \leq +\infty$ .*

In the light of the Corollary 6.45 above we will from now on denote an element of a pro-cluster  $X(\underline{X})$ , for any  $\hat{C}$ -admissible sequence  $\underline{X}$ , simply by  $\tilde{x}_{ij}$ , without further explanation.

As it turns out, the pro-clusters arising from complete  $\hat{C}$ -admissible sequences will coincide with triangulations of  $(\mathbb{Z} \cup \{+\infty\}, \leq)$ . First, we show that that every triangulation of  $(\mathbb{Z} \cup \{+\infty\}, \leq)$  gives rise to a pro-cluster.

**Lemma 6.46.** *Let  $T$  be a triangulation of  $(\mathbb{Z} \cup \{+\infty\}, \leq)$ . Then  $X_T := \{\tilde{x}_{ij} \mid (i, j) \in T\} \in \mathcal{X}(\underline{X}_{\hat{C}})$ .*

*Proof.* Throughout this proof  $J_n$  denotes a linearly ordered set  $(\{n^-, \dots, n^+\}, \leq)$  for any  $n \geq 3$ , with  $\leq$  being the less or equal to relation. Moreover, we let

$$\begin{aligned} T_n = & \{(i, j) \in T \mid n^- \leq i < j \leq n^+\} \cup \{(j, n^+) \mid (i, j) \in T \text{ such that } i < n^- \leq j < n^+\} \\ & \cup \{(i, n^+) \mid (i, j) \in T \text{ such that } n^- \leq i < n^+ < j \leq +\infty\} \cup \{(n^-, n^+)\}. \end{aligned}$$

We will show that the sequence  $\underline{X} := (X_{T_n})_{n \geq 3}$  is  $\widehat{C}$ -complete, where we regard  $T_n$  as a triangulation of  $\mathcal{P}_n$ , and that  $X(\underline{X}) = X_T$ .

First, we have by Proposition 6.10 that  $T_n$  is a triangulation of  $J_n$ , or equivalently of  $\mathcal{P}_n$  for all  $n \geq 3$ . Furthermore, using Proposition 6.10 together with Lemma 6.43 gives that  $X_{T_n} = \tilde{f}_n(X_T) \setminus \mathbb{Z}$  for all  $n \geq 3$ . To show that  $\underline{X}$  is  $\widehat{C}$ -complete we have to show that  $\tilde{f}_{m,n}(X_{T_m}) \subseteq X_{T_n} \cup \mathbb{Z}$  for all  $m \geq n \geq 3$ .

$$\tilde{f}_{m,n}(X_{T_m}) = \tilde{f}_{m,n}(\tilde{f}_m(X_T) \setminus \mathbb{Z}) \subseteq \tilde{f}_{m,n}(\tilde{f}_m(X_T)) = \tilde{f}_n(X_T) \subseteq X_{T_n} \cup \mathbb{Z}$$

and so  $\underline{X}$  is  $\widehat{C}$ -complete, as required.

To conclude the claim it is now left to show that  $X(\underline{X}) = X_T$ . First, let  $\tilde{x}_{ij} \in X(\underline{X})$  be such that  $i < j < +\infty$ . Then  $\tilde{f}_n(\tilde{x}_{ij}) = x_{ij} \in X_{T_n}$  for all  $n \geq 3$  such that  $n^- < i < j < n^+$  and so  $(i, j) \in T_n$  for all such  $n$ . But then, by construction of  $T_n$ , we have that  $(i, j) \in T$  and so  $\tilde{x}_{ij} \in X_T$ . Now, suppose that  $i < j = +\infty$ . Then  $\tilde{f}_n(\tilde{x}_{i+\infty}) = x_{in^+} \in X_{T_n}$  for all  $n$  such that  $|i| < -n^-$  and so  $(i, n^+) \in T_n$  for all such  $n$ . Then, by construction of  $T_n$  and Lemma 6.8 we deduce that  $(i, +\infty) \in T$  and so  $\tilde{x}_{i+\infty} \in X_T$ .

On the other hand, let  $\tilde{x}_{ij} \in X_T$ . Then  $(i, j) \in T$  and so if  $i < j < +\infty$  we have that  $(i, j) \in T_n$  for all  $n \geq 3$  such that  $n^- < i < j < n^+$  and so  $\tilde{f}_n(\tilde{x}_{ij}) \in X_{T_n}$  for all such  $n$ . Else, if  $i < j = +\infty$  then as  $(i, +\infty) \in T$  we have that  $(i, n^+) \in T_n$  for all  $n \geq 3$  such that  $|i| < -n^-$  and so  $\tilde{f}_n(\tilde{x}_{i+\infty}) = x_{in^+} \in X_{T_n}$  for all such  $n$ . But then we have in both of those cases that since  $\underline{X}$  is a complete  $\widehat{C}$ -admissible sequence and since  $\tilde{x}_{ij} \in R_{\widehat{C}}$  it follows that  $\tilde{f}_{m,n}(\tilde{f}_m(\tilde{x}_{ij})) = \tilde{f}_n(\tilde{x}_{ij}) \in X_{T_n} \cup \{0\}$  for all  $m \geq n \geq 3$ . Therefore, if  $\tilde{x}_{ij} \in X_T$  then  $\tilde{x}_{ij} \in X(\underline{X})$  and so  $X_T \subseteq X(\underline{X})$ .

We deduce that  $X(\underline{X}) = X_T$ , as required.  $\square$

**Lemma 6.47.** *Let  $\underline{X} = (X_n)_{n \geq 3}$  be a complete  $\widehat{C}$ -admissible sequence. Let  $T = \{(i, j) \mid \tilde{x}_{ij} \in X(\underline{X})\}$ . Then  $T$  is a triangulation of  $(\mathbb{Z} \cup \{+\infty\}, \leq)$ .*

*Proof.* Suppose there exists  $\tilde{x}_{ij} \in X(\underline{X})$  and  $\tilde{x}_{kl} \in X(\underline{X})$  such that  $(i, j)$  crosses  $(k, l)$ . Without loss of generality we will assume that  $i < k$ . Then  $i < k < j < l \leq +\infty$ .

Assume first that  $i < k < j < l = +\infty$ . Let  $n$  be such that  $n^- < i < k < j < n^+$ . Then  $\tilde{f}_n(\tilde{x}_{ij}) = x_{ij} \in X_n$  and  $\tilde{f}_n(\tilde{x}_{k+\infty}) = x_{kn^+} \in X_n$ . But then  $(i, j)$  crosses  $(k, n^+)$  and we have that  $X_n$  is not a cluster, a contradiction.

Next, consider the case where  $i < k < j < l < +\infty$ . Let  $n$  be such that  $n^- < i < k < j < l < n^+$ . Then  $\tilde{f}_n(\tilde{x}_{ij}) = x_{ij} \in X_n$  and  $\tilde{f}_n(\tilde{x}_{kl}) = x_{kl} \in X_n$  and since  $(i, j)$  crosses  $(k, l)$  it follows that  $X_n$  is not a cluster, a contradiction. Therefore  $T$  consists of pairwise non-crossing arcs of  $(\mathbb{Z} \cup \{+\infty\}, \leq)$ .

To prove the claim we must now show that  $T$  is maximal. Suppose that there exists an arc  $(k, l)$  of  $(\mathbb{Z} \cup \{+\infty\}, \leq)$  such that  $\tilde{x}_{kl} \notin X(\underline{X})$  and such that  $(k, l)$  does not cross any of the arcs from  $T$ . Since  $\tilde{x}_{kl} \notin X(\underline{X})$ , there exists  $m \geq 3$  for which  $\tilde{x}_{kl} \notin \tilde{f}_m^{-1}(X_m \cup \mathbb{Z})$ . Consider a  $\tilde{x}_{ij} \in X(\underline{X})$  such that  $\tilde{x}_{ij} \in \tilde{f}_m^{-1}(X_m)$ . We note that  $\tilde{f}_m(\tilde{x}_{kl})$  is a cluster variable which follows from the fact that  $\tilde{f}_m(\tilde{x}_{kl}) \notin \mathbb{Z}$  and Lemma 6.43. That is,  $\tilde{f}_m(\tilde{x}_{kl}) = x_{k'l'}$  for some  $m^- \leq k' < l' \leq m^+$ . Because  $\tilde{x}_{ij} \in \tilde{f}_m^{-1}(X_m)$  we have that  $\tilde{f}_m(\tilde{x}_{ij}) = x_{i'j'}$  for some  $m^- \leq i' < j' \leq m^+$ . Suppose that  $(k', l')$  crosses  $(i', j')$  in  $\mathcal{P}_m$ . Then either  $m^- \leq i' < k' < j' < l' \leq m^+$  or  $m^- \leq k' < i' < l' < j' \leq m^+$ . We will only consider the former case as the latter case is dealt with analogously. If  $m^- \leq i' < k' < j' < l' < m^+$  then  $(k, l) = (k', l')$  and  $(i, j) = (i', j')$ , by Lemma 6.43, and so  $(k, l)$  crosses  $(i, j) \in T$ , contradicting the assumption that  $(k, l)$  crosses no arcs from  $T$ .

Next, if  $m^- \leq i' < k' < j' < l' = m^+$  then  $(k, l) = (k', l')$  for some  $m^+ \leq l \leq +\infty$  or  $(k, l) = (k, k')$  for some  $k < m^-$  and  $(i, j) = (i', j')$  by Lemma 6.43. This implies that  $i < k < j < l$  and so  $(k, l)$  crosses  $(i, j) \in T$ , giving us yet another contradiction. Putting everything together we have that  $\tilde{f}_m(\tilde{x}_{kl})$  and  $\tilde{f}_m(\tilde{x}_{ij})$  do not cross in  $\mathcal{P}_m$ . But then since  $\tilde{x}_{kl} \notin \tilde{f}_m^{-1}(X_m)$ , we have that the triangulation corresponding to  $X_m$  is not maximal and so  $X_m$  is not a cluster, a contradiction.

We conclude that  $T$  is a triangulation of  $(\mathbb{Z} \cup \{+\infty\}, \leq)$ , as required.  $\square$

We are now ready to characterize the set  $\mathcal{X}(\underline{X}_{\hat{C}})$  of all pro-clusters arising from  $\hat{C}$ .

**Theorem 6.48.** *The set  $\mathcal{X}(\underline{X}_{\hat{C}})$  is the set*

$$\left\{ X_T \mid T \text{ is a triangulation of } (\mathbb{Z} \cup \{+\infty\}) \right\},$$

where  $X_T = \{\tilde{x}_{ij} \in R_{\hat{C}} \mid (i, j) \in T\}$  for any triangulation  $T$  of  $(\mathbb{Z} \cup \{+\infty\})$ .

*Proof.* We have by Corollary 6.42 that  $\mathcal{X}(\underline{X}_{\hat{C}}) = \{X(\underline{X}) \mid \underline{X} \text{ is } \hat{C}\text{-complete}\}$ . Then by

Lemma 6.47 we have that

$$\mathcal{X}(\underline{X}_{\hat{C}}) \subseteq \left\{ X_T \mid T \text{ is a triangulation of } (\mathbb{Z} \cup \{+\infty\}) \right\}.$$

Moreover,

$$\left\{ X_T \mid T \text{ is a triangulation of } (\mathbb{Z} \cup \{+\infty\}) \right\} \subseteq \mathcal{X}(\underline{X}_{\hat{C}}),$$

by Lemma 6.46, and so

$$\mathcal{X}(\underline{X}_{\hat{C}}) = \left\{ X_T \mid T \text{ is a triangulation of } (\mathbb{Z} \cup \{+\infty\}) \right\},$$

as required. □

Using the definition of a pro-cluster algebra together with the above proposition we deduce the following.

**Corollary 6.49.** *The pro-cluster algebra  $\mathcal{A}(\hat{C})$  is the subring of  $R_{\hat{C}}$  generated by the set*

$$\{\tilde{x}_{ij} \mid (i, j) \text{ is an arc of } (\mathbb{Z} \cup \{+\infty\}, \leq)\}.$$

**Example 6.50.** Denote by  $\mathcal{T}_m$  the fountain triangulation at  $m^+$  for every  $m \geq 3$ . Then from the  $\hat{C}$ -admissible sequence  $\underline{X} = (X_{\mathcal{T}_m})_{m \geq 3}$  (see Example 6.41) we get the pro-cluster  $X(\underline{X}) = \{\tilde{x}_{ii+1} \mid i \in \mathbb{Z}\} \cup \{\tilde{x}_{i+\infty} \mid i \in \mathbb{Z}\}$ . Moreover, the set  $T$  of arcs of  $(\mathbb{Z} \cup \{+\infty\}, \leq)$  given by  $T = \{(i, j) \mid \tilde{x}_{ij} \in X(\underline{X})\}$  is a triangulation of  $(\mathbb{Z} \cup \{+\infty\}, \leq)$ . See Figure 18, where we regard  $(\mathbb{Z} \cup \{+\infty\}, \leq)$  as a two-dimensional disk with infinitely many marked points and a single two-sided marked accumulation point  $+\infty$ , which we represent with an open circle.

As in the previous examples of pro-cluster algebras that we have seen so far in this chapter, the generators of  $\mathcal{A}(\hat{C})$  are subject to the now familiar relations.

**Theorem 6.51.** *The pro-cluster algebra  $\mathcal{A}(\hat{C})$  is the ring*

$$\frac{\mathbb{Z}[x_{ij} \mid (i, j) \text{ is an arc of } (\mathbb{Z} \cup \{+\infty\}, \leq)]}{(x_{ij}x_{kl} - x_{ik}x_{jl} - x_{kj}x_{il} \text{ for } i < k < j < l \leq +\infty)}.$$

*Proof.* Let  $S = \mathbb{Z}[x_{ij} \mid (i, j) \text{ is an arc of } (\mathbb{Z} \cup \{+\infty\}, \leq)]$ . We denote by  $\alpha$  an element of the set  $\mathbb{N}_0^{\mathbb{Z} \times \mathbb{Z} \cup \{+\infty\}}$  with finite support and such that  $\alpha(i, j) = 0$  whenever  $i \geq j$  and by  $x^\alpha$  the

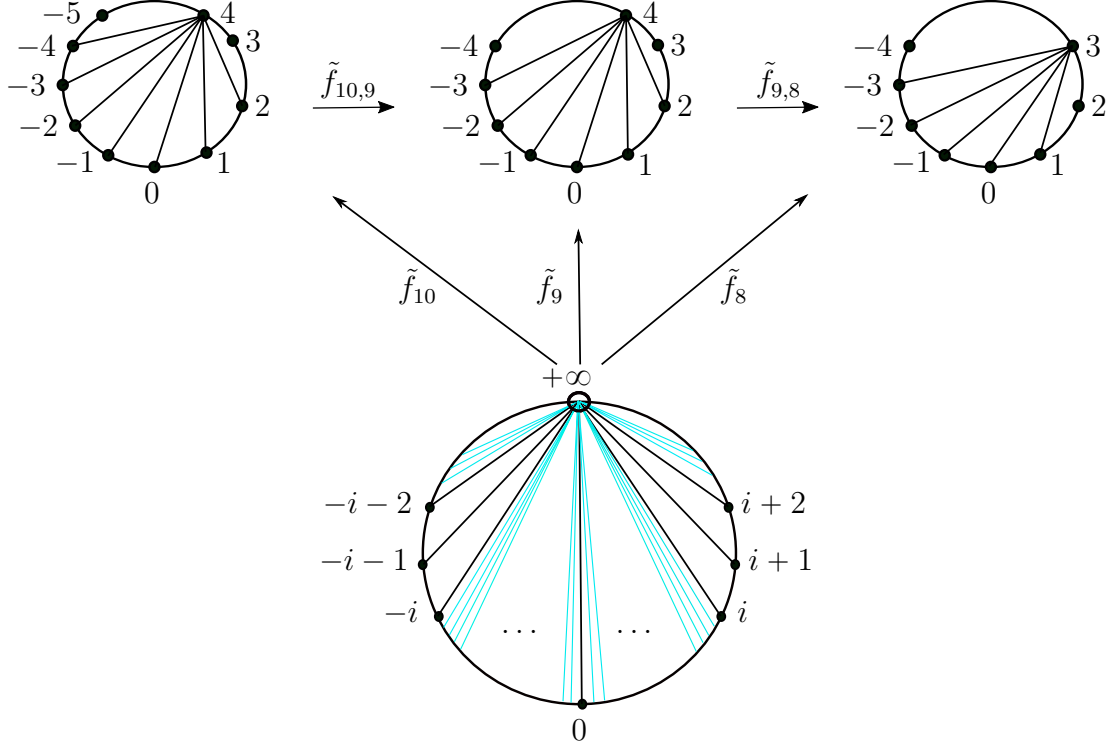

Figure 18: The section  $(X_{\mathcal{T}_m})_{8 \leq m \leq 10}$  of the  $\widehat{C}$ -complete admissible sequence  $\underline{X} = (X_{\mathcal{T}_m})_{m \geq 3}$  (see Example 6.50) and the triangulation of  $(\mathbb{Z} \cup \{+\infty\}, \leq)$  corresponding to the pro-cluster  $X(\underline{X})$

corresponding monomial in  $S$ . For  $(i, j) \in \mathbb{Z} \times \mathbb{Z} \cup \{+\infty\}$  we let

$$|(i, j)| = \begin{cases} \max\{|i|, |j|\}, & i < j < +\infty, \\ |i|, & i < j = +\infty, \\ 0, & \text{else} \end{cases}$$

and let  $\|\alpha\| := \max\{|(i, j)| : \alpha(i, j) > 0\}$ .

By universal property of polynomial rings there exists a unique ring homomorphism  $\phi : S \rightarrow \mathcal{A}(\widehat{C})$  such that  $\phi(x_{ij}) = \tilde{x}_{ij}$  for all  $i, j \in \mathbb{Z} \cup \{+\infty\}$  such that  $i < j \leq +\infty$ . Since the elements  $\tilde{x}_{ij}$  generate  $\mathcal{A}(\widehat{C})$  it follows that  $\phi$  is surjective. Thus  $\mathcal{A}(\widehat{C}) = S/I$  for some ideal  $I$  of  $S$ . We claim that  $I = P$ , where  $P := (x_{ij}x_{kl} - x_{ik}x_{jl} - x_{kj}x_{il} \text{ for } i < k < j < l \leq +\infty) \subseteq S$ . First, let  $x \in P$ . That is,

$$x = \sum_{i < k < j < l \leq +\infty} f_{ikjl}(x_{ij}x_{kl} - x_{ik}x_{jl} - x_{kj}x_{il}) \in S$$

where  $f_{ikjl} \in S$  and with  $f_{ikjl} = 0$  for all but finitely many  $(i, k, j, l) \in \mathbb{Z} \times \mathbb{Z} \times \mathbb{Z} \times \mathbb{Z} \cup \{+\infty\}$  such that  $i < k < j < l \leq +\infty$ . Pick  $m \geq 3$  such that  $m^- < a < m^+$  for all

$$a \in \bigcup_{f_{ikjl} \neq 0} \{i, k, j, l\} \cap \mathbb{Z}.$$

Then  $\tilde{f}_n(\phi(x)) = 0$  for all  $n \geq m$  due to Lemma 6.43 and the fact that

$$\mathcal{A}(\Sigma_{\mathcal{T}_m^{zz}}) = \frac{\mathbb{Z}[x_{ij} | m^- \leq i < j \leq m^+]}{(x_{ik}x_{jl} = x_{ij}x_{kl} + x_{jk}x_{il} \text{ for } m^- \leq i < j < k < l \leq m^+)}.$$

In fact, since  $(R_{\hat{C}}, \tilde{f}_m)$  is a cone, it follows that  $\tilde{f}_n(\phi(x)) = 0$  for all  $n \geq 3$  and so  $\phi(x) = 0$ .

Thus  $x \in I$ .

On the other hand we have

$$S \longrightarrow S/I = \mathcal{A}(\hat{C}) \longleftarrow R_{\hat{C}} \longrightarrow \mathcal{A}(\Sigma_{\mathcal{T}_n}),$$

where the first map is the projection, the second map is the embedding and the last map is the map  $\tilde{f}_n$ . We denote by  $\tilde{f}'_n$  the composite of these three maps. We have that  $\tilde{f}'_n(x_{ij}) = \tilde{f}_n(\tilde{x}_{ij})$  for all  $i, j \in (\mathbb{Z} \cup \{+\infty\}, \leq)$  such that  $i < j \leq +\infty$  and for all  $n \geq 3$ . Now  $r = \sum a_\alpha x^\alpha \in I$  is a linear combination of monomials  $x^\alpha$  with all but finitely many integral coefficients  $a_\alpha$  equal to zero. Let  $m \in \mathbb{Z}_{\geq 3}$  be such that for every monomial  $x^\alpha$  with non-zero coefficient (in  $r$ ) we have that  $m^- < -\|\alpha\|$  and  $m^+ > \|\alpha\|$ . The existence of such  $m$  is guaranteed since all but finitely many coefficients in  $r$  are equal to zero. Assume that  $r \notin P$ . But then we have that  $\tilde{f}'_m(x_{ij}) = \tilde{f}(\tilde{x}_{ij})$  for all  $i < j \leq +\infty$  which together with Lemma 6.43 implies that

$$\mathcal{A}(\Sigma_{\mathcal{T}_m}) \neq \frac{\mathbb{Z}[x_{ij} | m^- \leq i < j \leq m^+]}{(x_{ik}x_{jl} = x_{ij}x_{kl} + x_{jk}x_{il} \text{ for } m^- \leq i < j < k < l \leq m^+)},$$

giving us a contradiction. Thus we have that  $r \in P$  and so  $I = P$ , as required.  $\square$

**Remark 6.52.** (i) We highlight the fact that if we instead consider the inverse system

$\hat{C}' := (\mathcal{A}(\mathcal{T}_m^{zz}), \tilde{g}_{m,n})$ , where  $\tilde{g}_{m,n} : \mathcal{A}(\mathcal{T}_m^{zz}) \rightarrow \mathcal{A}(\mathcal{T}_n^{zz})$  is defined to be the algebraic extension of

$$x_{ij} \mapsto \begin{cases} x_{ij}, & n^- \leq i < j \leq n^+, \\ x_{n-i}, & n^- < i \leq n^+ < j \leq m^+, \\ x_{n-j}, & m^- \leq i < n^- < j \leq n^+, \\ 0, & \text{else,} \end{cases}$$

then we have by symmetry that the pro-clusters arising from  $\widehat{C}'$ -admissible sequences coincide with triangulations of  $(\mathbb{Z} \cup \{-\infty\}, \leq)$ , where  $\leq$  is the usual less or equal to relation equipped with the additional property which states that for all  $i \in \mathbb{Z}$  we have that  $-\infty < i$ . The pro-cluster algebra  $\mathcal{A}(\widehat{C}')$  is given by

$$\mathcal{A}(\widehat{C}') = \frac{\mathbb{Z}[x_{ij} \mid (i, j) \text{ is an arc of } (\mathbb{Z} \cup \{-\infty\}, \leq)]}{(x_{ij}x_{kl} - x_{ik}x_{jl} - x_{kj}x_{il} \text{ for } -\infty \leq i < k < j < l)}.$$

- (ii) In [9] the authors studied the so-called *cluster categories* from representations of hereditary algebras for the first time. In short, these are triangulated categories which contain subcategories that are in correspondence with clusters, with their indecomposable objects being in correspondence with cluster variables and with mutations encoded in the triangulated structure. For the finite Dynkin type  $A$  cluster algebra this can be rephrased as follows: cluster categories are categories which contain subcategories that are in correspondence with triangulations of a convex polygon, with their indecomposable objects in correspondence with the arcs of that convex polygon. In [23] the authors extended that picture by studying categories that are modelled by the two-dimensional disk  $\mathcal{D}$  with countably infinitely many marked points that are labelled by all  $i \in \mathbb{Z}$ . On the cluster algebra side of things, this translates to the correspondence between the clusters and cluster variables of the infinite rank cluster algebra of Gatz and Grabowski (see [21]) and subcategories and indecomposable objects, respectively. Finally, in [5] the authors considered the categories that are modelled, in the same sense as above, by the two-dimensional disk  $\mathcal{D}$  with countably finitely many marked points labelled by all  $i \in \mathbb{Z}$  and with the single two-sided accumulation point. From the cluster algebraic perspective, this establishes the connection between the categories studied in [5] and the pro-cluster algebra  $\mathcal{A}(\widehat{C})$  (or, equivalently,  $\mathcal{A}(\widehat{C}')$ ): certain subcategories are in correspondence with the pro-clusters of  $\mathcal{A}(\widehat{C})$  and the indecomposable objects with the arcs of  $(\mathbb{Z} \cup \{+\infty\}, \leq)$  (or equivalently, the arcs of  $\mathcal{D}$ ), putting our work into a wider context.



## 6.5 Some pro-cluster algebras are cluster algebras

In [21] Grabowski and Gratz studied infinite rank cluster algebras where the difference from the classical finite setting was in allowing the initial cluster (and so every other cluster mutation equivalent to the initial cluster) to be a countably infinite set (see [21] and in particular Definition 3.1 for more details), or equivalently in allowing the initial quiver to have countably infinitely many vertices. The remaining cluster mechanics were kept the same in that infinite setting: we obtain cluster variables via admissible sequences of (quiver) mutations of finite length and use all cluster variables acquired in that way to generate infinite rank cluster algebra inside the field of rational functions in a countably infinite set of variables over  $\mathbb{Q}$ .

In this context, consider now a quiver  $Q$ , pictured below, with countably infinitely many vertices labelled by  $i \in \mathbb{Z}$  and countably infinitely many vertices labelled by a pair  $(i, i + 1)$  where  $i \in \mathbb{Z}$ :

$$Q = \dots \longrightarrow i - 1 \longrightarrow i \longrightarrow i + 1 \longrightarrow \dots$$

$$\begin{array}{c} \uparrow \qquad \swarrow \qquad \uparrow \qquad \swarrow \\ (i - 1, i) \qquad \qquad (i, i + 1) \end{array}$$

To  $Q$  we attach a seed  $\Sigma_Q = (X_Q, ex_Q, Q)$ , where  $X_Q = \{x_{ii+1} \mid i \in \mathbb{Z}\} \cup \{x_{i+\infty} \mid i \in \mathbb{Z}\}$  and where  $ex_Q = \{x_{i+\infty} \mid i \in \mathbb{Z}\}$  with  $x_{ii+1}$  a frozen variable corresponding to the vertex  $(i, i + 1)$  of  $Q$  for every  $i \in \mathbb{Z}$  and with  $x_{i+\infty}$  an exchangeable variable corresponding to the vertex  $i$  of  $Q$  for every  $i \in \mathbb{Z}$ . Now, denote by  $\mu_{\mathbb{Z}}$  the set

$$\{\mu_{x_{l-1+\infty}} \circ \dots \circ \mu_{x_{k+1+\infty}}(x_{k+1+\infty}) \mid (k, l) \text{ is an internal arc of } (\mathbb{Z}, \leq)\},$$

of cluster variables of  $\mathcal{A}(\Sigma_Q)$ , where  $\leq$  is the usual less or equal to relation. Then the set  $X_Q \cup \mu_{\mathbb{Z}}$  is the set of all cluster variables of  $\mathcal{A}(\Sigma_Q)$ . The cluster algebra  $\mathcal{A}(\Sigma_Q)$  is the  $\mathbb{Z}$ -algebra generated by the all cluster variables.

In similar spirit, Çanakçı and Felikson studied in their joint paper [10] the marked surfaces with infinitely many marked points, which we will refer to as infinite surface for simplicity, and introduced a way of constructing a cluster algebras from such surface, using certain hyperbolic geometry machinery. The definition of infinite rank surface cluster algebra can be thought of as a generalization of the one we introduced in Chapter 2, that is of the one

associated to a marked surface with only finitely many marked points. For  $\mathcal{S}$  an infinite surface, the cluster variables (exchangeable and frozen variables, respectively) are identified with the internal and the boundary arcs of  $\mathcal{S}$ , the clusters with the triangulations of  $\mathcal{S}$ , and the mutations are the usual quadrilateral flips. As an example, let  $\mathcal{D}$  be a two-dimensional disk that we saw in Figure 18 with countably infinitely many marked points  $i \in \mathbb{Z}$  and the two-sided accumulation point  $+\infty$ . Moreover, let  $T$  be the fountain triangulation at  $+\infty$  (again, see Figure 18 for reference). Note that using the same technique as in Chapter 2 (see pages 10-13) we can attach to  $T$  an infinite quiver. The quiver we would obtain in this way is precisely the quiver  $Q$ , which explains the choice of the naming of the initial cluster variables in the seed  $\Sigma_Q$ . Now, the (initial) cluster associated to  $T$  is the set  $X_T = \{x_{ii+1} \mid i \in \mathbb{Z}\} \cup \{x_{i+\infty} \mid i \in \mathbb{Z}\}$  where  $x_{i+\infty}$  are the exchangeable cluster variables corresponding to the internal arcs  $(i, +\infty)$  in  $T$  for every  $i \in \mathbb{Z}$  and where  $x_{ii+1}$  are the frozen cluster variables corresponding the boundary arcs  $(i, i+1)$  for  $i \in \mathbb{Z}$  of  $\mathcal{D}$ . As it turns out, every internal arc of  $\mathcal{D}$  that is not in  $T$ , and so is of the form  $(k, l)$  for some integers  $k$  and  $l$  such that  $k < l$ , can be obtained from  $T$  via finitely many quadrilateral flips. For an example of this see Figure 19, where we omit the labelling of some of the marked points to achieve a better clarity of the picture and where we obtain from  $T$  the arc  $(-3, 3)$  via flipping the arcs  $(-2, +\infty)$ ,  $(-1, +\infty)$ ,  $(0, +\infty)$ ,  $(1, +\infty)$ ,  $(2, +\infty)$  of  $T$ , in this particular order. More concretely, in the algebraic notation, we have that

$$x_{kl} = \mu_{x_{l-1+\infty}} \circ \cdots \circ \mu_{x_{k+1+\infty}}(x_{k+1+\infty}),$$

for every arc  $(k, l)$  of  $(\mathbb{Z} \cup \{+\infty\}, \leq)$  such that  $l \neq +\infty$ . The set

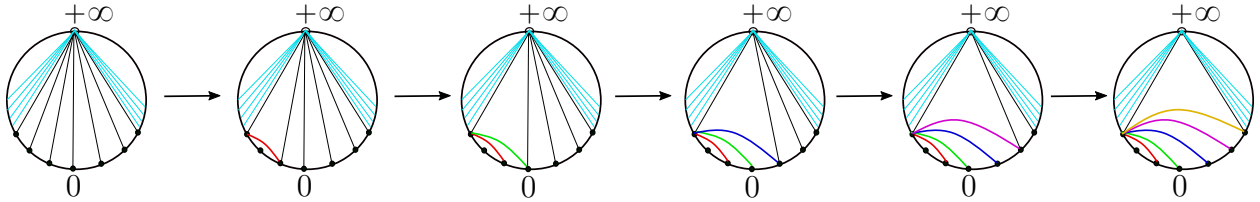

Figure 19: An example of a sequence of quadrilateral flips needed for obtaining the arc  $(-3, 3)$  from the fountain triangulation at  $+\infty$ .

$$X_T \cup \{x_{kl} \mid (k, l) \text{ is an arc of } (\mathbb{Z}, \leq)\}$$

is the set of all cluster variables and the cluster algebra  $\mathcal{A}(\mathcal{D})$  is the  $\mathbb{Z}$ -algebra generated by all cluster variables.

In Example 6.50 we saw that the set  $\{\tilde{x}_{ij} \mid (i, j) \in T\}$  is one of the pro-clusters of the pro-cluster algebra  $\mathcal{A}(\widehat{C})$ . It turns out that as a ring  $\mathcal{A}(\widehat{C})$  coincides with  $\mathcal{A}(\Sigma_Q)$  and so  $\mathcal{A}(\widehat{C})$  is in fact a cluster algebra in the classical sense (of Gratz and Grabowski). It is also true that  $\mathcal{A}(\Sigma_Q) = \mathcal{A}(\mathcal{D})$  and so  $\mathcal{A}(\widehat{C}) = \mathcal{A}(\mathcal{D})$ .

Similarly, if we let  $\mathcal{D}$  be the two-dimensional disk with countably infinitely many marked points labelled by positive integers and a single one sided accumulation point  $\infty$  and let  $T$  be the fountain triangulation at  $\infty$  of  $\mathcal{D}$  then we have that  $\mathcal{A}(\Sigma_{Q_T}) = \mathcal{A}(T) = \mathcal{A}(C)$ , with obvious notation. Finally, if  $\mathcal{D}$  is the two-dimensional disk with countably infinitely many marked points labelled by the integers and two one-sided accumulation points  $\pm\infty$  and if we let

$$T = \{(i, i+1) \mid \mathbb{Z}\} \cup \{(-\infty, i) \mid i \in \mathbb{Z}_{\leq 0}\} \cup \{(i, +\infty) \mid i \in \mathbb{Z}_{\geq 0}\}$$

then we again have that  $\mathcal{A}(\Sigma_{Q_T}) = \mathcal{A}(T) = \mathcal{A}(\overline{C})$ .

There is, however, an important difference when viewing those rings as a simple cluster algebra as opposed to viewing them with the richer structure of a pro-cluster algebra: we note that not every triangulation of  $\mathcal{D}$  can be obtained from  $T$  using finitely many diagonal flips only. In fact, there are infinitely many triangulations that cannot be reached from  $T$  in this way. In slightly more detail, a triangulation can be reached from  $T$  in finitely many diagonal flips if and only if a triangulation that we are trying to reach crosses  $T$  in finitely many places (see, for example, Theorem B in [10] for more details). Equivalently, if we denote by  $A_Q$  the underlying graph of  $Q$ , then this means that not every orientation of  $Q$  can be achieved by finitely many quiver mutations, where we start from the quiver  $Q$ . In the case of our pro-cluster algebras  $\mathcal{A}(C)$ ,  $\mathcal{A}(\overline{C})$ ,  $\mathcal{A}(\widehat{C})$  we have the advantage of seeing all triangulations of  $\mathcal{D}$  (or, all orientations of  $A_Q$  as well as the quivers that are *split apart*, e.g. quiver corresponding to the triangulation from Figure 20). What makes our pro-cluster algebras even more attractive is the fact that the definition of cluster algebra of Çanakçı and Felikson is surface-dependent whereas our pro-cluster algebra has no such limitation as its construction is purely algebraic and as a consequence much more general.

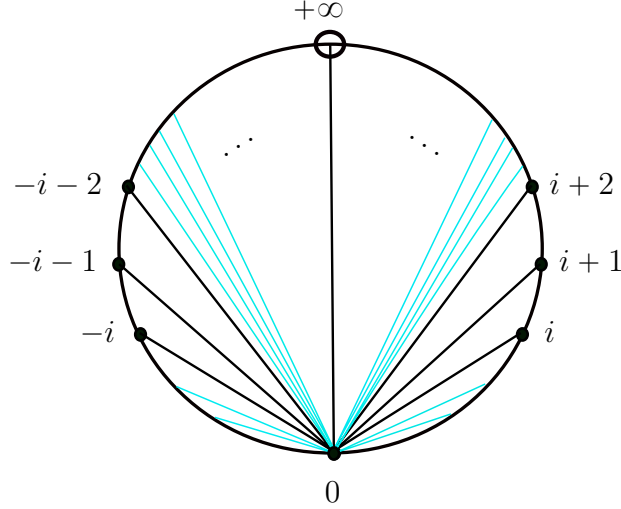

Figure 20: A fountain triangulation at 0 of a  $\infty$ -gon with a single two-sided accumulation point.

## 7 Discussion and outlook

We close this thesis with an informal discussion of some open problems that follow directly from our work. Here we do not attempt to formally put together rigorous questions but instead use this space to speculate a little and to draw the attention of the reader to certain aspects of our work that we think might be worth exploring in the future. The problems we discuss are based on some of the concrete examples that we have already considered earlier and we explain how they naturally lead to some more general questions.

### 7.1 Relationship between pro-cluster algebras and cluster algebras.

As we saw in Sections 6.3 and 6.4 the pro-clusters of certain pro-cluster algebras are interpreted as triangulations of certain infinitely marked surfaces with accumulation points. Moreover, those pro-cluster algebras coincide with suitably constructed infinite rank cluster algebras of Gratz and Grabowski [21] and of Çanakçı and Felikson [10]. With that in mind we go back to the Example 5.37 for some more inspiration. We considered there a family  $\{T_{m-1}^1\}_{m \geq 4}$  of triangulations of regular  $(m-1)$ -gons with a single puncture. See below the triangulations  $T_{m-1}^1$  for  $m = 4, 5, 6, 7$ . The seeds  $\Sigma_{T_{m-1}^1}$  are freezable seeds for every  $m > 4$  and by Theorem 5.33 there exists a parameter dependent family of freezing rooted cluster

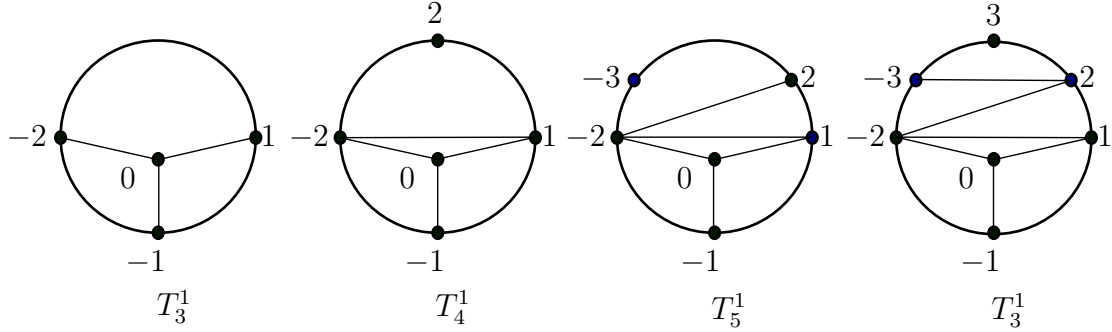

morphisms from the rooted cluster algebra  $\mathcal{A}(T_{m-1}^1)$  to the rooted cluster algebra  $\mathcal{A}(T_{m-2}^1)$  for every  $m > 4$ . As a consequence, we can construct a family  $F$  of inverse systems in the category **fClus**. Suppose we are given an inverse system from  $F$ . One might want to consider the following questions regarding that inverse system:

- Can the pro-clusters of the associated pro-cluster algebra be interpreted as triangulations of a suitable infinitely marked surface (with a single puncture)? If so, do all triangulations of that infinitely marked surface show up as pro-clusters under such interpretation?
- Can the associated pro-cluster algebra be viewed as an infinite rank cluster algebra in the sense of Gratz and Grabowski [21] and of Çanakçı and Felikson [10]?

Of course, the same questions can be formulated in a more general manner for any (infinite) inverse system in **fClus** of cluster algebras originating from a marked surface:

- Are pro-clusters of the associated pro-cluster algebra triangulations of the underlying marked surface? Are all triangulations pro-clusters? Do the associated pro-cluster algebra and the infinite rank cluster algebra coincide (as rings) and under what conditions?

Let us now consider going the other way round. So far, we have discussed the pro-cluster algebras which had pro-clusters encoded by the triangulations of a two-dimensional disk with either one or two accumulation points. In [10] Çanakçı and Felikson consider marked surfaces that have (countably) infinitely many marked points with finitely many marked accumulation points allowed and their associated cluster algebras. Given any such surface we immediately ask:

- Can we construct a pro-cluster algebra with its pro-clusters encoded by, ideally all of, the triangulations of that surface? If the answer is yes, then does the cluster algebra of that infinite surface (in the sense of Çanakçı and Felikson) coincide, as ring, with the pro-cluster algebra?

All of these questions can be generalized to the case where a pro-cluster algebra does not necessarily come from an inverse system of cluster algebras based on marked surfaces and where an infinite rank cluster algebra does not come from a surface but instead from a quiver. For example, if we have an inverse system in **fClus** of cluster algebras not originating from a marked surface then we can ask the following questions:

- Are pro-clusters of the associated pro-cluster algebra in correspondence with, possibly infinite, quivers (or equivalently, skew-symmetrizable matrices)? If so, do we see all possible orientations of those quivers under such correspondence? Do the associated pro-cluster algebra coincide as rings with the infinite rank cluster algebra of Gratz and Grabowski [21] and under what conditions?

Being able to characterize pro-cluster algebras, either partially or fully, would give us a different, deeper look into the structure and properties of infinite rank cluster algebras.

## 7.2 Pro-cluster mutations versus completed mutations

Let us consider now fountain triangulations  $T$  and  $T'$  at 1 and at 2, respectively, of a disk with  $\mathbb{Z}_{>0}$  many marked points and a single one-sided accumulation point  $\infty$ , see the pictures below. We observe that there is no finite sequence of flips that take  $T$  to  $T'$ . Let us therefore consider an infinite sequence of flips, where we flip the arcs  $(1, 3)$ ,  $(1, 4)$ ,  $(1, 5)$  and so on. We note that the set of arcs we obtain from applying that particular sequence of flips to  $T$  is not a triangulation. More precisely, to turn the resulting set of arcs into a triangulation we must add to it the limit arc  $(2, \infty)$  (this operation is an example of the so-called *completed mutation* defined by Gratz and Baur in [7]).

In contrast, recall that we saw in Section 6.3, that both  $T$  and  $T'$  can be regarded as pro-clusters of a pro-cluster algebra associated with an inverse system of the freezing morphisms based on collapsing triangles. More formally,  $X_T$  and  $X_{T'}$  arise as pro-clusters

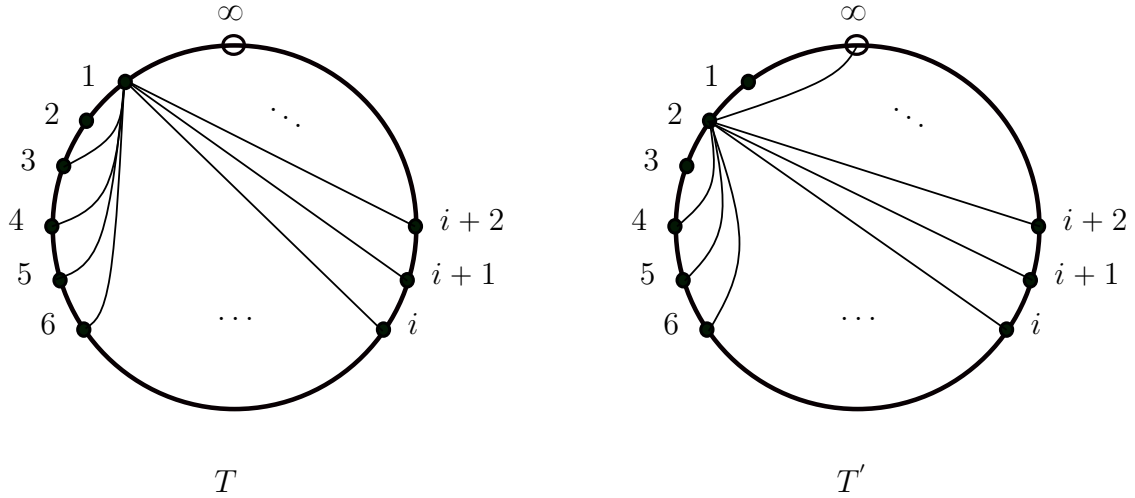

from the sequences  $\underline{X} := (X_m)_{m \geq 3}$  and  $\underline{Y} := (Y_m)_{m \geq 3}$  of clusters, respectively, where  $X_m$  is the cluster corresponding to the fountain triangulation at 1 and where  $Y_m$  is the cluster corresponding to the fountain triangulation at 2, for every  $m \geq 3$ ; see the picture below for the triangulations corresponding to  $X_m$  and  $Y_m$  for  $m = 3, 4, 5, 6$ . We notice that  $Y_m$  can

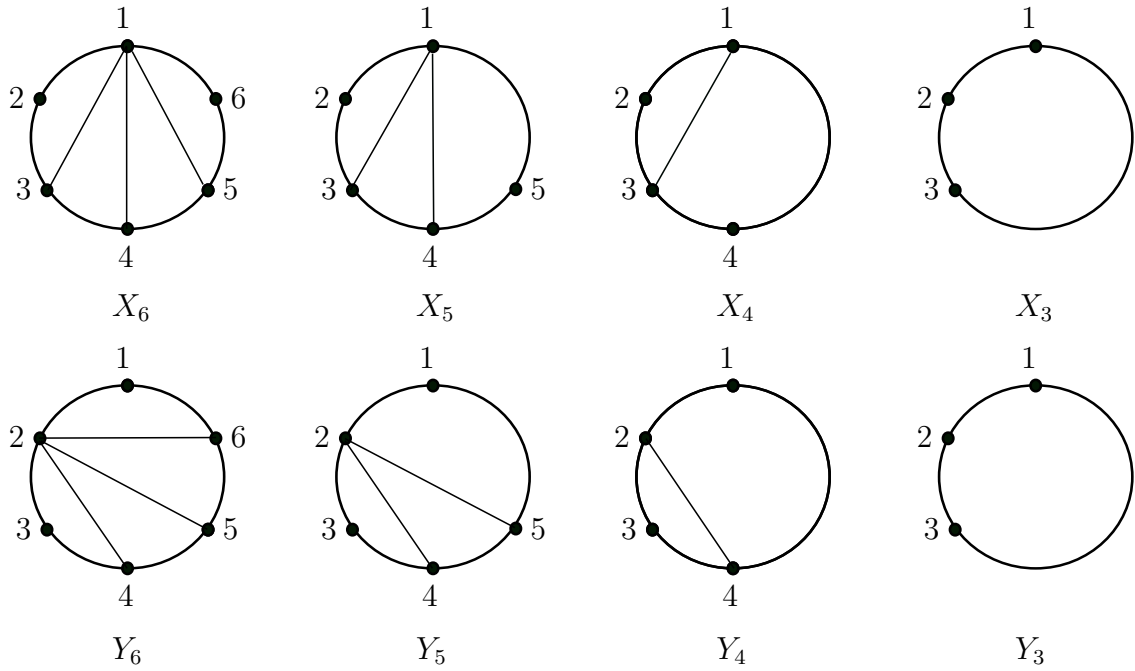

be obtained from  $X_m$  by mutating (in that particular order) at the variables corresponding to the arcs  $(1, 3), (1, 4), \dots, (1, m - 1)$  for every  $m > 3$ . Thus, instead of flipping infinitely many arcs directly in the  $\infty$ -gon and adding an arc at the end, we flip infinitely many arcs in the underlying sequence of clusters to obtain the desired triangulation, effectively getting

rid of the need for adding the additional arc  $(2, \infty)$ , which gets taken care of by the limit construction of pro-clusters.

The next step is to try and define mutations of pro-clusters that employ a similar idea to that discussed above. That is, to define mutations of pro-clusters that arise from suitable mutations of its underlying sequence of finite clusters. The resulting sequence of the mutated clusters should again be an admissible sequence of clusters (see Definition 6.2) so that we get another pro-cluster from it. For the pro-cluster algebras with an underlying geometric structure we would like this definition to coincide with the usual geometric interpretation of mutations as flips of arcs. We suspect that in order for the pro-cluster mutation to act transitively on the set of all pro-clusters, infinite sequences of mutations are unavoidable (see the example above) however we might be able to avoid needing to add arcs, or more generally, to add pro-cluster variables (again, see the above example for more details) with a suitably defined notion of pro-cluster mutation.

An interesting question would be to describe which pro-clusters in any given pro-cluster algebra can be connected via (infinite) sequences of pro-cluster mutations once mutations are suitably defined. Due to the fact that pro-cluster algebras are defined purely algebraically this could then be seen as a generalization of the similar work done by Gratz and Baur in [7] and by Çanakçi and Felikson in [10] for infinitely marked surfaces. This could be especially useful in the light of (in some cases, already established) connections between pro-cluster algebras and infinite rank cluster algebras.

We will finish this section with a candidate definition of a pro-cluster mutation. Our definition of mutation is based on the idea of sequentially mutating clusters from the admissible sequence corresponding to a given pro-cluster, as discussed above. Moreover, mutation of a pro-cluster, that we propose, yields another pro-cluster, as required. Unfortunately, due to the time constraints, we were not able to verify if our mutation carries any of the desired properties discussed in the previous two paragraphs, but we hope that our definition could be a good starting point for further consideration.

Fix  $m, n, i, j \in \mathbb{Z}$ . Let  $\{\Sigma_m = (X_m, ex_m, B_m) \mid m \geq 0\}$  be a family of seeds, let  $S = (\mathcal{A}(\Sigma_m), \varphi_{m,n} : \mathcal{A}(\Sigma_m) \rightarrow \mathcal{A}(\Sigma_n))_{m \geq n \geq 0}$  be an inverse system in **fClus** with  $(R, (\varphi_m)_{m \geq 0})$  its limit in the category **Ring** of rings and let  $\underline{X} = (X_i)_{i \geq 0}$  be a  $S$ -admissible sequence. That



is, there exists a non-negative integer  $l_{\underline{X}}$  such that for all  $m \geq n \geq l_{\underline{X}}$

- $X_m$  is a cluster in  $\mathcal{A}(\Sigma_m)$ ,
- $\varphi_{m,n}(X_m) \subseteq X_n \cup \mathbb{Z}$ .

Let  $X(\underline{X})$  be the pro-cluster associated with  $\underline{X}$  (see Definition 6.2).

**Definition 1.** We call  $x \in X(\underline{X})$  *mutable* if there exists  $k_x \geq l_{\underline{X}}$  such that for all  $m \geq n \geq k_x$

- $\varphi_m(x) \in ex_m$ ,
- $\varphi_{m,n}(\mu_{\varphi_m(x)}(X_m)) \subseteq \mu_{\varphi_n(x)}(X_n) \cup \mathbb{Z}$ .

Finally, we have the following definition.

**Definition 2.** Let  $x \in X(\underline{X})$  be mutable. The *image of mutation of  $\underline{X}$*  in the direction of  $x$  is the  $S$ -admissible sequence  $(\mu_{\varphi_m(x)}(X_m))_{m \geq k_x}$  and the *image of mutation of  $X(\underline{X})$*  in the direction of  $x$  is the pro-cluster associated to  $(\mu_{\varphi_m(x)}(X_m))_{m \geq k_x}$ , denoted by  $\mu_x(X(\underline{X}))$ .

### 7.3 Outlook

There are many more open questions that can be seen as a natural extension of our work. For example, in [2] Assem, Dupon and Schiffler characterized not only the isomorphisms but also the monomorphisms in the category **Clus**. Naturally, it would be interesting to characterize monomorphisms and epimorphisms in our category **fClus** as well as to investigate other categorical properties of **fClus**, for example to characterize its limits and its colimits.

In Chapter 5 we considered freezing morphisms in the category **fClus**. That is, the morphisms that send exchangeable variables to frozen ones. In Proposition 5.22 we gave a partial characterization of such morphisms and their full characterization is an open question that would help to understand **fClus** more deeply. Another open problem is to characterize freezing rooted cluster morphisms that do not send cluster variables to integers, something that Gratz did in [22] for the category **Clus** and rooted cluster morphisms with that same property.

★ ★ ★

We hope that the work presented in this thesis will add to the discussion of the beautiful world of cluster algebras and related topics, and that it will prove to be a source of interesting insights and problems for researchers in this and neighbouring areas.

## 8 References

- [1] I. Assem and G. Dupont. Friezes and construction of the Euclidean cluster variables. *J. Pure Appl. Algebra*, 215(10):2322–2340, 2011.
- [2] I. Assem, G. Dupont, and R. Schiffler. On a category of cluster algebras. *J. Pure Appl. Algebra*, 218(3):553–582, 2014.
- [3] I. Assem, G. Dupont, R. Schiffler, and D. Smith. Friezes, strings and cluster variables. *Glasg. Math. J.*, 54(1):27–60, 2012.
- [4] I. Assem, R. Schiffler, and V. Shramchenko. Cluster automorphisms. *Proc. Lond. Math. Soc.*, 104(6):1271–1302, 2012.
- [5] J. August, M. Cheung, E. Faber, S. Gratz, and S. Schroll. Grassmannian categories of infinite rank. Preprint arXiv:2007.14224, 2020.
- [6] J. August, M. Cheung, E. Faber, S. Gratz, and S. Schroll. Cluster structures for the  $a_\infty$  singularity. Preprint arXiv:2205.15344, 2022.
- [7] K. Baur and S. Gratz. Transfinite mutations in the completed infinity-gon. *J. Combin. Theory, Ser. A*, 155:321–359, 2018.
- [8] A. Berenstein, S. Fomin, and A. Zelevinsky. Cluster algebras III: Upper bounds and double Bruhat cells. *Duke Math. J.*, 126(1):1–52, 2005.
- [9] A. B. Buan, R. J. Marsh, M. Reineke, I. Reiten, and G. Todorov. Tilting theory and cluster combinatorics. *Adv. Math.* 204, 204(2):572–618, 2006.
- [10] İ. Çanakçı and A. Felikson. Infinite rank surface cluster algebras. *Adv. in Math.*, 352:862–942, 2019.
- [11] R. W. Carter. *Lie algebras of finite and affine type*. Cambridge University Press, Cambridge, 2005.
- [12] C. Fraser. Quasi-homomorphisms of cluster algebras. *Adv. in Appl. Math.*, 81:40–77, 2016.

- [13] F. Chapoton, S. Fomin, and A. Zelevinsky. Polytopal realizations of generalized associahedra. *Canad. Math. Bull.*, 45(4):537–566, 2002.
- [14] G. Dupont. An approach to non-simply laced cluster algebras. *J. Algebra*, 320(4):1626–1661, 2008.
- [15] S. Fomin, M. Shapiro, and D. Thurston. Cluster algebras and triangulated surfaces. I. Cluster complexes. *Acta Math.*, 201(1):83–146, 2008.
- [16] S. Fomin and A. Zelevinsky. Cluster algebras. I. Foundations. *J. Amer. Math. Soc.*, 15(2):497–529, 2002.
- [17] S. Fomin and A. Zelevinsky. Cluster algebras. II. Finite type classification. *Invent. Math.*, 154(1):63–121, 2003.
- [18] S. Fomin and A. Zelevinsky. Y-Systems and Generalized Associahedra. *Ann. of Math.*, 158(3):977–1018, 2003.
- [19] S. Fomin and A. Zelevinsky. Cluster algebras. IV. Coefficients. *Compos. Math.*, 143(1):112–164, 2007.
- [20] A. P. Fordy and B. R. Marsh. Cluster mutation-periodic quivers and associated Laurent sequences. *J. Algebraic Combin.*, 34(1):19–66, 2010.
- [21] J. E. Grabowski and S. Gratz. Cluster algebras of infinite rank. *J. London Math. Soc.*, 89(2):337–363, 2013.
- [22] S. Gratz. Cluster algebras of infinite rank as colimits. *Math. Z.*, 281(3-4):1137–1169, 2015.
- [23] T. Holm and P. Jorgensen. On a triangulated category which behaves like a cluster category of infinite Dynkin type, and the relation to triangulations of the infinity-gon. *Math. Z.*, 270(1-2):277–295, 2012.
- [24] J. E. Humphreys. *Introduction to Lie algebras and representation theory*. Springer-Verlag, New York-Berlin, 1972.

- [25] J. E. Humphreys. *Reflection groups and Coxeter groups*. Cambridge University Press, Cambridge, 1990.
- [26] V. G. Kac. *Infinite dimensional Lie algebras*. Cambridge University Press, Cambridge, 1990.
- [27] B. Keller. The periodicity conjecture for pairs of Dynkin diagrams. *Ann. of Math. (2)*, 177(2):111–170, 2013.
- [28] Y. Kimura and F. Qin. Graded quiver varieties, quantum cluster algebras and dual canonical basis. *Adv. Math.*, 262:261–312, 2014.
- [29] K. Lee and R. Schiffler. Positivity for cluster algebras. *Ann. of Math.*, 182(1):73–125, 2015.
- [30] T. Leinster. *Basic Category Theory*. Cambridge University Press, Cambridge, 2014.
- [31] S. MacLane. *Categories for the Working Mathematician*. Springer, New York, 1971.
- [32] R. J. Marsh. *Lecture Notes on Cluster Algebras*. European Mathematical Society, Zürich, 2013.
- [33] G. Musiker, R. Schiffler, and L. Williams. Positivity for cluster algebras from surfaces. *Adv. Math.*, 227(6):2241–2308, 2011.
- [34] E. Riehl. *Category theory in context*. Dover Publications, Inc., New York, 2016.
- [35] L. Williams. Cluster algebras: an introduction. *Bull. Amer. Math. Soc.*, 51(1):1–26, 2014.