

1946

## Heat disturbances in man

Harold Baker Miller  
*University of Nebraska Medical Center*

This manuscript is historical in nature and may not reflect current medical research and practice. Search [PubMed](#) for current research.

Follow this and additional works at: <https://digitalcommons.unmc.edu/mdtheses>

---

### Recommended Citation

Miller, Harold Baker, "Heat disturbances in man" (1946). *MD Theses*. 1409.  
<https://digitalcommons.unmc.edu/mdtheses/1409>

This Thesis is brought to you for free and open access by the Special Collections at DigitalCommons@UNMC. It has been accepted for inclusion in MD Theses by an authorized administrator of DigitalCommons@UNMC. For more information, please contact [digitalcommons@unmc.edu](mailto:digitalcommons@unmc.edu).

HEAT DISTURBANCES IN MAN

By

Harold B. Miller

Senior Thesis  
Presented  
to  
THE COLLEGE OF MEDICINE  
UNIVERSITY OF NEBRASKA  
Omaha  
1946

-CONTENTS-

	PAGE
I. INTRODUCTION.....	1
II. HISTORY.....	3
III. PREDISPOSING FACTORS.....	7
IV. ETIOLOGY.....	14
1. Heat Cramps.....	16
2. Heat Exhaustion.....	19
3. Heat Stroke.....	23
V. CLINICAL SYMPTOMS AND PHYSICAL FINDINGS	28
1. Heat Cramps.....	28
2. Heat Exhaustion.....	34
3. Heat Stroke.....	40
VI. DIFFERENTIAL DIAGNOSIS.....	54
VII. PHYSIOLOGY AND CHEMISTRY.....	60
VIII. PATHOLOGY.....	91
IX. TREATMENT.....	98
1. Heat Cramps.....	101
2. Heat Exhaustion.....	108
3. Heat Stroke.....	112
X. SUMMARY AND CONCLUSIONS.....	119
XI. BIBLIOGRAPHY.....	125

## INTRODUCTION

There are a number of clinical syndromes which are associated with man's exposure to a high environmental temperature. These syndromes are considerably less in number than the number of terms applied to them. In reading the literature the following terms are encountered: heat cramps, heat exhaustion, heat stroke, heat pyrexia, hyperpyrexia, thermic fever, sunstroke, siriasis, heat collapse, insolation, and others. Many of these terms are used interchangeably for similar conditions. The failure of nosology to assist in the classification of this group of diseases may be attributed in part to a lack of satisfactory clinical, physiological and biochemical description of the several syndromes.

In the following pages an attempt is made to divide heat illnesses into three main divisions; i.e. heat cramps, heat exhaustion, and heat stroke. Heat stroke will also be referred to as sunstroke and hyperpyrexia. Some authorities divide the heat conditions into two main classifications: heat exhaustion and heat stroke. In this case the heat exhaustion is not a serious thing, whereas heat stroke is a serious thing and if not adequately

treated the mortality is high. However, since many writers consider heat cramps as a distinct syndrome, it is considered as such in this thesis.

There also is a difference of opinion in the literature concerning clinical manifestations, the state of peripheral circulation, cardiac function and function of the sweat glands, all of which tend to bear on the pathogenesis as well as the therapy. In the following discussion an attempt is made to present the opinions of various authorities upon the subject.

## HISTORY

According to Hall and Wakefield (33), heat conditions in man are the oldest known disease. The ancients associated heat stroke or sunstroke with Sirius, the dog star, and dog days (65,81). This association is probably accounted for when it is recalled that in the summer months Sirius follows the sun and is seen in the evening twilight.

Wakefield and Hall (81) state that one of the earliest record of the disease is the Biblical cases. In the fourth book of Kings, chapter four, verses eighteen to twenty inclusive, the following is found: "And the child grew, and on a certain day, when he went out with his father to the reapers, he said to his father, 'My head acheth, my head acheth', and when he had taken him and brought him to his mother, she set him on her knee until noon and then he died."

In the apocryphal book of Judith, chapter eight, verses two and three is found, "And her husband was Manassus, who died in the time of the barley harvest, for he was standing over them that bound sheaves in the field; and the heat came upon his head and he died in Bethalia, his own city, and was buried there with his fathers."

Heat stroke also occurred at sea. In the records of the British frigate, Liverpool, it was noted that while sailing from Muscat to Bushire, the weather became warmer, double awnings were spread and the decks of the ship were constantly kept moist. Although every precaution was taken to prevent undue exposure to the sun, over 30 men were lost. At one time on the voyage, the decks of the vessel resembled a slaughterhouse, so numerous were the bleeding patients.

Levick (48) states that in Peking in July, 1743, over eleven thousand persons perished on the streets from the effects of heat. Lancisi, according to Levick, was the first to publish evidence of the influence of hygrometry in the etiology of heat infections.

From Biblical time until 1852, all cases of heatstroke were confounded with apoplexy (81). Hall states that this point is clearly illustrated by the writings of Forestus in 1562 and Baglivi of Rome in 1694 and 1695. In October, 1695, Baglivi reported a period in which it rained for fifteen days. This was followed by outbursts of apoplexies. He evidently

recognized the various factors which entered into the disease, for he mentions mental distress, the winds, rain and an inadequate supply of food.

Hall (81) writes that in 1789, Rush called attention to a disorder which was brought on by an individual drinking cold water in hot weather. He described very accurately the symptoms of heat stroke. This idea that the drinking of water was the cause of the disease went so far that in the summer of 1814, the pumps in Philadelphia were posted with "caution" by the humane society.

According to Hall, the fact that the body temperature was elevated in the major heat affections must be attributed to J. Watts, and W. Gerhard was the first to clearly separate the instances of heat stroke from apoplexy by observing that there were no gross changes in the brain tissues in a case of heat stroke. However, in more recent work (60,72,86) it has been demonstrated that changes do occur in the brain.

Hall also states that Andral of Paris was the first to note the relationship which existed between the cases of heat stroke and the high atmospheric



temperatures. He also was the first one to give an accurate account of the major postmortem findings such as petechiae, liquid blood and venous engorgement.

Condie, according to Hall, was the first man to describe heat stroke occurring in places other than sunlight. Also, this observer was the first to call attention to the fact that an important etiological factor was the humidity of the air.

Griman (27) reports that in 1858 Claude Bernard produced death in birds and mammals by raising their temperature. After the temperature was elevated four or five degrees, it was shown at autopsy that the lesions which were present were very similar to those noted in a major heat stroke.

than exhaustion between the ages of twenty to fifty, but exhaustion predominates after sixty years of age. They thus conclude that exhaustion appears to be associated with a diminished vitality or a decreased physiological adaptability.

Gauss and Meyer (24) in their study of 158 patients state that 152, or 96.2 percent, were males and only 6, or 3.8 percent, were females. They found that the ages ran from nineteen to seventy. As to the nationality of their patients, 45 were American-born and 103 were foreign-born. One of the American-born was a negro who died soon after admittance. Of the established occupations, laborers comprised 64.9 percent of their cases. Most of the patients gave a history of alcoholism. All but two of the patients had drunk beer in the twenty-four hours preceding the attack.

Shattuck and Hilferty (70), in their studies of the distribution of acute heat effects in various parts of the world, indicate that death from heat illness is far more common in men than in women. They made a study of the men in the armies of various countries and reached the conclusion

## PREDISPOSING FACTORS

Although heat is assumed to be the main cause of the various heat conditions in man, other factors play a prominent role. Such matters as the general physical condition of the individual, alcoholism, fatigue and overwork tend to combine with the environmental conditions to form an etiological basis for the clinical picture.

Shattuck and Hilferty (69), in their study of the cause of death from heat effects, state that the following factors tend to play a prominent part; i.e. arduous labor, deficient air movement in places of employment, unsuitable clothing, low vitality in infants, diminished vitality after the age of sixty, unsuitable habits of eating and drinking, and debilitating diseases. They also claim in their studies that the Irish-born are particularly subject to heat effects. Between the ages of twenty to fifty-nine they suffer from sunstroke in particular, but in later years cases of heat exhaustion and sunstroke are about equal.

The above authors claim that the type of response to the above factors show a definite correlation with the age. Hyperpyrexia is far more common

that the prevailing climate played a very important part in determining whether death or ill effects would occur. They found that the proportions of deaths from heat was much less in Europe and the British Isles than in the United States or India. Following is the morbidity rates per 1000 attributed to heat in the armies of the countries studied:

PERIOD	France	French Army in Algeria	Germany	Italy	India	U.S.
1910	0.16	0.6	0.16	0.2	0.18	
1920	0.70	0.2		0.7	0.61	0.80
1922	0.11	0.16	0.36	0.06	3.20	1.23
1923	0.20	0.13		0.20	6.30	0.73
1924	0.28	0.19		0.22	4.50	1.21
1930	0.38	0.32	0.73		5.20	1.43

Hill (41) mentions the heating effect of foods, especially foods rich in protein. Effects were particularly noticeable if such foods were eaten in tropical countries. Alcohol is contraindicated if taken in the place of natural foods as it contains no vitamin or protein building groups. Hill also cites the effect of enclosure and still air. If

this still air is stagnant moist air, any loss of heat by convection, radiation or by evaporation of sweat becomes impossible; and, as the heat production rises, the rise of temperature accelerates the rate of combustion in the cells and a vicious cycle is established.

Mills (54) relates how individuals who have become accustomed to a continuous heat are able to safely endure degrees of excessive heat which would in a few hours cause prostration or even kill those individuals who were adapted to a cooler climate. He declares that the mean temperature level is of first importance and the second main factor is the variability of temperature. It is a well known fact that the people most susceptible to tropical heat are not those that live there constantly but rather newcomers from the cooler, more stimulating climates. However, newcomers after a season or two in the heat become adapted to it and are less liable to heat stroke or exhaustion.

Robinson, Dill, Wilson, and Nielson (62) conducted experiments in which they proved that the negro was more resistant to heat illnesses than the

white man. They showed that the negroes maintained a lower body temperature and while working in the sun with their body exposed, the negroes had better temperature regulation. Also, southern negroes had lower body temperature than northern negroes. They remained cooler and worked more efficiently.

Sutton (74) states that external heat is found to have a marked influence in producing heat conditions in man only when it is associated with a certain degree of atmospheric humidity. Heat stroke occurs in a hot moist climate, although the climate need not be very hot. It appears that the essential factor is the combination of excessive humidity and high temperature. Ill health, excessive work and starvation, according to Sutton, play an important subsidiary role.

Haldane (38) points out that the wet-bulb reading controls the entire question of the rise of the body temperature. Heat stroke then appears in even quite healthy persons who are exposed to a high wet-bulb temperature even for a comparatively few hours.

Hamilton (34), in a review of 21 cases which included 13 cases of heat exhaustion and eight cases of heat stroke, concluded that the following stood out prominently: constipation, which occurred in every case; a history of alcohol and smoking; and histories of long sojourns in a hot climate. Over half of the patients had suffered a previous illness or were employed in an occupation which required working while exposed to the direct rays of the sun.

Machle (49) claims that the ability of an individual to acclimatize himself plays an important part in deciding whether or not he will develop a heat illness. Various factors enter into this such as the course of acclimatization, which appears to be initiated by the first exposure to heat. Also, the physical condition plays a part. Men in good physical condition acclimatize more readily and are capable of a greater output of work in the heat. Rest at night is also very essential for good work performance in the heat even in acclimatized men. If men are deprived of rest at night, they work inefficiently the next day and are more susceptible

to heat illness. Acclimatization to a dry desert heat increases markedly the ability of men to work efficiently and effectively in a moist (jungle) heat.



## ETIOLOGY

In a study of cases of death from heat in Massachusetts, Shattuck and Hilferty (69) found that the factors of high atmospheric temperatures, high relative humidity and poor air circulation were present in varying relationship. They believed that heat cramps, heat exhaustion and heat hyperpyrexia all represent various pathological responses to the same basic etiology. Under identical environmental conditions these various types of reactions have been manifested simultaneously in different patients. According to them, the reactions which occurred did not represent clear-cut clinical entities and all had much in common.

Yaglon (90) showed experimentally that high relative humidity and deficient air movement, when associated with high temperatures, greatly favored the development of ill effects from heat in man.

Wilcocks (85) considers heat the essential etiological agent and he claims that the production of symptoms will depend upon the heat center being insufficient to counterbalance the heat gained from the external surroundings as well as that created by many metabolic processes going on inside the body.

Many other authors (3, 4, 15, 20, 27, 40, 41, 61, 69, 83, 85) consider heat as the main etiological factor in heat conditions.

Mills (53) claims that climate is the predominating etiological factor. He states that the heat which is lost from the body varies according to the prevailing climate and this heat lost will determine whether or not a man will have sufficient energy to exist in a given region. According to Mills, all the vital functions of the body are based upon the energy which is derived from the cellular combustion of food materials. However, the body as a whole is not an efficient machine for energy conversion, and thus is very sensitive to the ease with which its waste heat can be thrown off. It is here, according to Mills, that the climatic condition at the time plays a part. If conditions tend to occur so that heat loss is easily accomplished, then the body growth is rapid, maturity comes very early and the resistance to infections is high.

Shattuck and Hilferty (71) in their study reached the conclusion that high relative humidity and deficient air movements when associated with

high temperature greatly favor the development of ill effects from heat in men.

Although heat plays a part in all heat conditions of men, the etiology of the three main conditions which occur, i.e. heat cramps, heat exhaustion and heat stroke, may vary somewhat.

#### 1. Heat Cramps.

In heat cramps, Moss (56) credits J. S. Maldane with the suggestion that cramps suffered by miners are due to salt loss. In 1904, Edsall (18) reported two cases of transitory myokymia and myotonia which undoubtedly were heat cramps.

Glover (26) considers that the most important factors in heat cramps are high temperature surrounding the workers, high humidity and a low air velocity; in other words, the factors which tend to interfere with the loss of heat from the body. He declares that cramps rarely occur among men working in the open air regardless of the temperature. The next important thing is muscular exercise. This is shown by the increasing number of cases which occur in men just starting on hard work in the heat. These men tend to develop cramps and these cramps are liable

to appear on the first hot day which follows a cool spell.

According to Talbot (77), the present viewpoint is that the loss of base, chlorides and water from the body in the sweat is the primary factor in the cause of heat cramps. He cites as his basis for this reasoning three factors: first, the great amount of chlorides which is lost in the sweat; second, the response of the individual affected when he is treated by intravenous injection of sodium chloride; and third, the low chlorides in the blood and urine reported in cramp cases.

Shoudy and Baetyer (72) also consider the salt loss as the main cause of heat cramps. Salt loss from the body, as the etiological factor, is also mentioned by many other authors (11, 13, 22, 31, 40, 45, 78, 79, 83, 85).

Haldane (30,32) believed that heat cramps could be attributed to water poisoning. He cites cases in which men working in hot mines or at iron furnaces under certain conditions or as stokers on ships in the tropics suffered greatly from a sensation of thirst, which appeared to be due in part to a

physical drying of the mucous membranes of the mouth and throat. This factor caused these individuals to consume large quantities of water which was considerably more than the real requirements of the body. When they did this, they were seized with attacks of severe cramps.

Haldane attributed this to a form of water poisoning of the muscles brought about by the combination of a great loss of chloride by sweating, excessive drinking of water and a temporary paralysis of renal secretion. He states that a man who sweats while working hard and who drinks large amounts of water to relieve his thirst tends to increase his sweating and this sweat is being replaced by pure water, whereas at first it contained about 0.2 percent sodium chloride. The kidneys at the same time are out of action so that they are unable to deal with the excess diffusion pressure of pure water, or a fall in the "osmotic pressure", and consequently violent attacks of cramps are symptomatic of this.

Therefore the work of Moss, Edsall, Haldane, Glover, Talbot, Shoudy, Baetyer, et al, suggests that heat cramp results primarily from an excessive

loss of electrolyte, namely, sodium chloride in the sweat.

Thrower (79) discussed conditions under which firemen worked in ships. Many men had the finest physiques but developed cramps when the air became stagnant and contained a high percentage of carbon monoxide. Since these cramps were relieved by drinking salty water, chloride loss was considered a factor along with the carbon monoxide intoxication. However, Thrower failed to mention any percentage of carbon monoxide, but he did state that a temperature of 130° F. was often reached in the engine rooms, which, no doubt, was a deciding factor in the production of the heat cramps in the men.

## 2. Heat Exhaustion.

Various theories have been brought forth as the cause of heat exhaustion. Wilcocks (85) and Shattuck and Hilferty (71) believe that it is essentially a failure of the circulation to adapt itself to heat.

Morton (55) states that high temperature per se will bring about heat exhaustion even in the absence of direct exposure to the rays of the sun. He

believes that the cause may be in the nature of an auto-intoxication due to failure of the excretory organs to get rid of the waste products of metabolism. He shows that in heat exhaustion there is a prodromal period of malaise, weakness, constipation and diminution of urine. Individuals show the signs of shock and this may possibly be due to the presence of some substance allied to histamine which has been produced in the body due to faulty metabolism.

Talbot (75) and Weiner (84) also emphasized the fact that the condition is due to a peripheral circulatory collapse. Talbot (75) showed that the concentration of the constituents of body fluids were characterized by a depletion of body water and sodium chloride. The blood showed an increase in the concentration of hemoglobin and protein. Individuals with heat exhaustion appeared in shock in many cases and their low blood pressure, pallor and hemoconcentration indicated a peripheral vasodilatation with subsequent collapse. Weiner (84) found that heat collapse could be produced in certain individuals by keeping them in the erect position in severe hot and

humid climates. He explains the collapse and the associated circulatory findings as being due to an extensive vasodilatation of the peripheral vascular bed with a consequent "pooling" of the blood by the action of heat. This vasodilatation was indicated by an extreme fall in blood pressure.

Brodkin (6), in his studies made upon soldiers on the march during the months of July and August, states that the exhaustion from heat occurred among those men who drank water excessively, perspired profusely and thereby lost great quantities of sodium in the sweat. He claims that when this dehydration and salt depletion reaches a certain level that medical shock or collapse will follow. However, Shoudy and Baetyer (72) in many cases of heat exhaustion found no marked fall in the sodium chloride content of the blood. They believe that the condition of heat exhaustion is due ultimately to a collapse of the circulatory system.

Zroalenburg (89) declares that in the regulation of the body temperature the most important factor is the water balance and that dehydration is the main cause of heat exhaustion. With an excessive loss of



water the blood volume is mechanically lowered and a condition is produced which is practically identical to that following hemorrhage or surgical shock.

Zroalenburg claims that the exhaustion is due to the difficulty of the circulation in maintaining an adequate blood pressure in the nerve centers and is one of the first evidences of inadequate blood in the blood vessels.

Schofield (68) claims that the initial mechanism of heat exhaustion is that in which the disturbances are manifested by muscle cramps due to the actual depletion of chlorides in the tissues, or to a certain imbalance of sodium and potassium. Further disturbances produced syncope and exhaustion which were traced to an actual lowering of the total blood volume. In his discussion, Schofield cites studies made at Boulder Dam. When the dam-building project was first started, the men were forced to work and live under the most trying conditions on a hot desert with no conveniences. They were poorly housed. The summer heat had an average daily maximum temperature of 119° F. and a mean temperature of 106° F. The usual clinical picture presented was that of pallor, nausea,

vomiting, diarrhea, muscle cramps, and unconsciousness. Many deaths occurred before aid could be given. The conditions were thought to be due to a peripheral collapse because the individuals appeared to be in shock, with respirations rapid, pulse rapid and thready and the blood pressure low.

Phelps (59), in his cases of heat exhaustion, found that at a certain stage there was a failure of the heat-regulation functions of the skin and sympathetic nervous system which resulted in a cessation of heat production. In this case the body temperature ceases to rise and the body begins to cool, and by the time the temperature is subnormal, prostration becomes apparent. In these cases, patients upon entrance were prostrated. Their temperatures were subnormal, 97° F. minus. They had a cool moist skin, a very rapid pulse and no cramps.

It therefore appears that heat exhaustion per se is caused primarily by a failure of the peripheral vascular system.

### 3. Heat Stroke.

Heat stroke, also called sun stroke, was once called siriasis by the ancients because of its

prevalence during the hottest season when Sirius, the dog star, rose and set with the sun. Sambon (65) considered heat stroke to be caused by a "specific germ" due to its apparent epidemic character and the findings of encephalitic foci.

Sambon, in his discussion, describes how Little considered siriasis to be the result of pressure exerted upon the cerebrospinal matter by the heat expanded cerebrospinal fluid. Antonini thought it to be an acute neurosis of the vascular vasomotor system. Laveran made the suggestion that the etiology of the disease might be caused by the paralysis of the ganglion of the heart, while Vallin thought it might be caused by a coagulation of myosin. Senflebin ascribed the malady to a disorganization of the blood and an accumulation of urea in the blood. Bauer considered that the main factor might be due to a liberation of carbonic acid in the blood. Smart attributed the symptoms to a deficiency which he thought occurred in the serosity of the body brought about by a long continued sweating. Baxter and Zuber, on the other hand, thought that the great rise in bodily temperature depended upon the interference

with heat loss as a result of a suppression of cutaneous perspiration. However, today none of the above theories, as expressed by Sambon, is considered the etiological factor.

Allen (2) assumed that heat hyperpyrexia is due to the direct action of solar or atmospheric heat on the body. Morton (55) states that this critical temperature is somewhere in the region of 119° F. to 120° F., and that the factor of humidity does not appear to enter into the question to any great extent. He believes that high temperatures per se will bring about heat exhaustion in the absence of direct exposure to the rays of the sun.

Hill (41) declares that heat stroke results from a rise in the body temperature to a height which is incompatible with the maintenance of the equilibrium of the physio-chemical reactions in the cell. He believes that such a rise may result from the inability of the heat-regulating mechanism to control the body temperature under the atmospheric conditions. He claims that as long as the body is exposed to a cooling breeze, the exposure to the sun can not produce a sunstroke.

Reese and Masten (60) state that it is now generally considered that the underlying cause of heat stroke is a disturbance of the heat-regulating mechanism, which follows the exposure to heat in a humid atmosphere. Some authors (2, 21, 41, 50, 71, 73, 74) consider that heat is the main underlying cause, whereas others (30, 55, 56, 67, 81) have stressed the importance of a high humidity.

Sayers (67) and Adolph and Fulton (1) studied its effects by producing moderate elevations of body temperatures in humans in a hot humid environment. Alcoholism (24, 30, 55, 67) and old age (16, 67) have been demonstrated as being important contributory factors in the development of heat stroke. Also, circulatory failure (1, 2, 76, 80), acidosis and fatigue of the sweat glands (36), and increased body metabolism (16) have each been held responsible for the breakdown in the heat-regulating mechanism.

Willcox (86) comments on the "deadly power" which the sun's rays seem to possess in locations in which there is "absence of vegetation, flatness of country and clearness of atmosphere".

Sutton (74) and Haldane (28) conclude that after considering all the other factors, it may be accepted that a wet-bulb temperature is the main and essential factor in the production of a heat stroke. Sutton states that heat stroke will invariably occur in hot, moist climates. However, the climate need not be very hot; often the temperature need not exceed 90° F. The essential factor is the combination of the high temperature and the excessive humidity. Haldane shows that heat stroke will even occur in healthy individuals if they are exposed to a high wet-bulb temperature even for a comparatively few hours.

Duncan (15), in his remarks on some recent theories on the action of heat in the tropics, says that "the first enemy to health in the tropics is the sun."

## CLINICAL SYMPTOMS AND PHYSICAL FINDINGS

In reviewing the literature concerning the clinical manifestations, there is a difference of opinion among various observers in regard to such factors as the state of the peripheral circulation, cardiac function and function of the sweat glands which might bear on the pathogenesis as well as therapy. Some observers do not attempt to make too sharp a distinction, especially between the prodromal symptoms, while others try to sharply define. However, most of the authors agree that heat cramp symptoms are sufficiently clear so as to not complicate a differential diagnosis of heat disturbances..

### 1. Heat Cramps.

The work of Edsall (18), Moss (56), Haldane (30), Glover (26), Talbot (77), et al, suggests that heat cramp results primarily from an excessive loss of electrolytes, namely, sodium chloride in the sweat, which causes muscular contractions producing the cramps.

Wallace (83) states that heat cramps are usually seen in industrial workers and results in painful cramps in the abdomen and extremities.

Cameron (7) describes a condition which occurs in steel mill workers in which men exposed to high temperatures and doing heavy work suffered severe cramps. These men suffered the cramps when they were resting after having done hard work. Most of the cases occurred in men who were hard drinkers. There was no thermal change, but the pulse was accelerated and the individual had intense muscular cramps and spasms. The most marked characteristic feature was pain. The violent spontaneous seizures lasted from one to four hours and then there was a gradual lessening in severity and frequency of the spasmodic seizures. The muscles of the face, back and neck were not affected and the sphincters remained unaffected. Also, one attack seemed to predispose to others.

Wilcocks (85) states that the painful cramps are felt in any muscle, but are the most marked in the legs. The patient is intensely thirsty and vomiting and diarrhea have been noted. However, the temperature and pulse are normal.

Heilman and Montgomery (38) found that the chief complaint of a heat-cramp victim was usually pain in various groups of the skeletal muscles. These cramps



always prohibited the subject from continuing his normal work. The muscles of the calf, shoulders and flexor group of the forearm were the most commonly affected. The muscles of the abdominal wall and the fingers were affected to a lesser degree. They believed that if vomiting occurred it was due to spasms of the smooth muscles of the gastro-intestinal tract.

Thrower (79) describes a condition which he calls "Fireman's cramps" since it occurred among ship firemen who toiled in stagnant air which was viliated by exhaust fumes with a high percentage of carbon monoxide. Even men who had the finest physiques developed malaise, headache and crampy pains in the limbs and abdomen. The body temperature rose slightly, up to 100° F. at times, and the pulse was rapid. This increase in pulse and temperature was in contradiction to observations which were made by other authors (7, 77, 85) and may have been due to carbon monoxide poisoning.

Phelps (59) reported the symptoms of his cases as consisting of a fever, usually about 100° F.; moderate tachycardia; severe cramps in the abdomen and extremities; and occasionally vomiting. The duration

of illness, in most cases, was about forty-eight hours.

Talbot (77) says the characteristics that distinguish heat cramps from other varieties of cramps are few. A study of the past history may reveal a previous attack of cramps while working at a higher temperature. Talbot believed that an individual became more resistant to cramps after the fifth day of acclimatization. He also believed that there was a prodromal period of one to three days before the onset of acute symptoms. During this period the salt intake usually exceeded the salt excretion. Vomiting usually preceded the muscle cramps. The presenting symptom was generally pain in the various groups of muscles which usually prevented the subject from continuing work. Also, tingling in the fingers and toes might precede the cramps.

Edsall (18) observed extreme irritability and fibrillary twitchings of the involved muscles in his patients with heat cramps, and any attempt at deep or superficial palpation produced pain.

Talbot (77) also noted the predilection of certain groups of smooth and striated muscles for cramps

in conditions of heat cramp. The muscles of the forearms (flexors) and of the calf of the leg were the commonest site. His cramp cases showed only a slight rise in temperature. Due to pain in the flexor muscles of the forearms, the individual was unable to use his arms. Also, spasms in the lower leg muscles (extensors) caused the individual to sit or fall down. Abdominal cramps were often present due to spasm of the abdominal muscles.

Fantus (19) speaks of the painful spasms, particularly the abdominal muscles, which are induced by excessive sweating in a hot atmosphere while working hard. These cramps were usually accompanied by pallor, nausea, dizziness and mental depression. In his cases, the pulse was rapid and strong but the temperature was normal.

Carleton and Kammer (8) state that heat cramps clinically are characterized by the sudden onset of excruciating intermittent cramps of the skeleton muscles. Any of the muscles or group of muscles of the trunk or extremities may be affected. Also, the rigid contracted muscles are readily palpable for the duration of the pain which usually lasts one-half to

several minutes. Voluntary action on the part of the subject or mild surface stimulation excited the affected muscles to further contractions. At times, visceral cramps were to be seen in association with cramps in the skeletal muscles.

Shoudy and Baetyer (72) have observed most of their cases in July or August. They claim that the affected individual before an attack is working hard, feels thirsty and drinks freely of water. Then he feels queer, sweats profusely, has a headache and is compelled to quit work. While resting, the affected person almost immediately feels a twitching and pain in his arms and legs. He becomes cold, pale, clammy, and is down and out. In these cases, the cramps were always preceded by a marked sweating and the cramps are painful tonic spasms of any skeletal muscles but usually of the forearm flexors, calves and abdomen. Spasms recurred at the slightest movement of the patient. The temperature varied from 95° F. to 102° F. The pulse was rapid, but never over ninety per minute, and often thready. Respiration was rapid and the skin cold and clammy. The blood pressure was low. Other symptoms included nausea, vomiting, diarrhea, dizziness and mental depression.

### 2. Heat Exhaustion

Morton (55) declares that the actual onset of this condition may be sudden but that often there is a premonitory stage during which the patient complained of anorexia, weakness of the legs, headache and constipation which lasts for three to four days. This may be followed by a sudden collapse in severe cases. In many cases this collapse would occur at night and bore no direct relationship to exertion. At this stage, a patient presented a picture of being in shock. As this stage of shock subsided or passed off, persistent and severe vomiting would ensue. In some cases the vomitus was even bile stained.

The patient is pale and becomes bathed in a cold, clammy perspiration; he is mentally apprehensive and in many cases is in an acute stage of discomfort, which is due to violent cramps in the abdomen and leg muscles. There is also suppression of urine in severe cases. The axillary and mouth temperatures were often normal or subnormal but the rectal temperatures were invariably raised usually to about 101° F. In a few cases, even after convalescence, headache persisted for seven to ten days.

Wallace (83) speaks of the picture of heat exhaustion as resembling that of shock. In his cases the condition was characterized by weakness, dizziness, clammy skin, rapid respiration and pulse, and a low blood pressure. Sambon (65) called heat exhaustion an initial stage of thermic fever and declares that it is nothing more than syncope.

Withington (87) says that in heat exhaustion cases, headache, faintness, sweating, vomiting and cramps were precursory symptoms which are too frequently disregarded by the patients until it is too late.

Wilcocks (85) declares that the feeling of giddiness and exhaustion is often followed by a fainting spell. The temperature is often subnormal, the patient pale, skin moist, the pupils dilated, the pulse fluttering and soft, and the blood pressure low.

Wolkin's (88) description of the condition agrees with that of Wallace, Morton and Wilcocks, but he also states that at times visual disturbances may occur as well as muscular cramps.

Shutt (73) states that heat exhaustion is an asthenic condition characterized by a weak and rapid pulse; a temperature which varies from  $\frac{1}{2}$  to  $4^{\circ}$  F. below normal; shallow or respirations that are about normal; extreme weakness; and a muscular system that is flaccid and quiet. Also, changes may occur in vision, the skin is usually cold and pale, and a headache is invariably present.

Reid (61) divided his cases of heat exhaustion into two classes. In the first one, his patients commonly presented a moist, cool skin with a sub-normal temperature which occasionally went as low as  $95$  or  $96^{\circ}$  F. The pulse was weak and rapid, and the patient was very pale and prostrated. In his second group, Reid declares that his patients had a slight increase in temperature, varying from normal to  $102^{\circ}$  F. Many of them felt dizzy, nauseated, and all complained of headache. Most of them felt very prostrated and a few even lost consciousness.

Ladell, Waterlow, and Hudson (46) also concluded that there were two types of heat exhaustion. However, their classification is somewhat confusing as they seem to include heat cramps in their type

one. Their classification can best be summed up in the following outline:

	Type 1.	Type 2.
History of:		
1. Vomiting	73%	4%
2. Cramps	70%	4%
3. Defective sweating	13%	87%
4. Increased frequency of micturation	0%	82%
On admission patient showed:		
1. Dryness of the skin	5%	40%
2. Desquamating prickly heat	7%	80%
3. Signs of dehydration	50%	2%
4. Pulse volume poor	33%	0%
5. Lying pulse pressure <30 mm. Hg.	46%	2%
6. Blood pressure not maintained	72%	2%
7. Color of skin	Pale	Red
8. Average lying pulse rate; beats per minute	90	76
9. Average increase pulse rate on standing	40	20
10. Average lying blood pressure	111/79	121/69
11. Average rectal temperature	100.6°	100.9° F.
12. Average oral temperature	98.2°	99.5° F.
13. Frequency of micturation per 24 hours	2-3	8-9
14. Weight gain in hospital (in ounces)	121	41



Ladell, et al (46), state that the history is usually of short duration, four to fifty hours. Practically all of the patients complained of anorexia, giddiness, headache, and constipation was present in some of the cases. On admission, regardless of the type, the patients looked exhausted, anxious and ill-appearing.

Reese and Masten (60), Fantus (19), and Ferris and Blankenhorn (21) seem to think that heat exhaustion is just the prodromal period to heat stroke; whereas, Shoudy and Baetyer (72) are of the opinion that heat cramp and heat prostration have the same general symptoms. However, in their cases they observed nausea and vomiting only five times in three hundred and fifty cases.

Carleton (8) sums up the controversy when he says that the symptoms of heat exhaustion are usually slow in onset and the symptoms and signs vary with the stage at which the patient is first seen. Also, the clinical picture of heat exhaustion may be complicated by the concomitant occurrence of one or the other manifestations of heat sickness. Characteristically, however, the symptoms of the syndrome are

extreme weakness and impending collapse. The usual findings are profuse sweating, cool skin, rapid and a somewhat irregular pulse and respiration. There is a normal or slightly lowered body temperature and a normal or a lowered blood pressure. Such findings may readily produce a clinical picture of shock.

Another condition which must be mentioned before discussing heat stroke is that of anidrosis. This is a condition seldom seen but it will occasionally occur. According to Novy and Ramsey (57), cases have appeared in the desert under conditions of a hot humid climate. The condition is characterized by the fact that the person shows extreme weakness and suppressed areas of sweating. In the case discussed by Novy and Ramsey, the individual was weak and was sweating only about the head. From the neck down, his skin was perfectly dry and presented a nondescript, dry, scaly, slightly erythematous eruption. The man was very pale. When sent to a cooler climate, after being there two weeks he began to sweat profusely.

### 3. Heat Stroke.

Heat stroke, or hyperpyrexia, is the most serious form of heat injury. According to Safford (66), the premonitory symptoms consist of a feeling of oppression, occipital headache, throbbing of the temples, vertigo and nausea. The respirations and pulse are rapid. Also, weakness, fatigue and colored or dim vision may be present. The mouth is dry and thirst is usually intense. Frequency and urgency are present but the patient is able to pass very little urine. Perspiration, which had previously been free, ceases. Body temperature then rises rapidly and all the symptoms become exaggerated. Consciousness is lost abruptly or after a period of confusion or delirium.

In an examination of a patient, the physical examination is characteristic. The pupils are contracted and react sluggishly. The conjunctivae are injected. Respiration is deep and labored, stertorous and may be of the Cheyne-Stokes type. The deep reflexes are weakened or absent. The skin is hot and dry. The pulse usually ranges from 160 to 180, and may be irregular. There may be cyanosis

of the lips and fingers. Muscles may be flaccid, but there is a tendency toward the twitching of muscles and convulsions may occur.

Wilcocks (85) and Shoudy and Baetyer (72) give practically the same description of the symptoms.

Edsall (18) in 1904 described cases in which muscle spasms occurred after exposure to severe heat. His patients presented a very conspicuous degree of fibrillary contraction and this tended to occur particularly in the calf of the leg muscles. He remarked that in their gross features, the tonic spasms resembled tetany and their duration was from one-half to one minute. These contractions were exceedingly painful and extremely irritable to direct stimulation.

Gauss and Meyer (24) state that the prodromal symptoms were found to vary from five days to a few seconds. The patients complained of headache, malaise, anorexia, dizziness, dyspnea, polydipsia and insomnia. The most common complaints were headache and dizziness, and these symptoms were present in practically all of the patients. The temperature in these patients varied. It was found that the

temperature was high in those in which the prodromal symptoms were a few hours or less and low in those in which the prodromal period was a day or more.

The pulse rate was roughly proportional to the temperatures. If the patient had a temperature up to 99° F., the pulse rate varied from 70 to 104. With a temperature of 103 to 107° F., the pulse rate was 112 to 152. Above 108° F., the pulse rate was 148 to 180 per minute. The pulse rate usually fell with the temperature and rose with it. Patients who were comatose and had a high temperature, usually had an easily compressible, rapid, weak, peripheral pulse.

Machle (49) declares that it is easy to tell the difference between an acclimatized man and one who is not acclimatized. The acclimatized man is alert, performs his work energetically and without symptoms. Usually his heart rate and rectal temperature is low.

The unacclimatized men showed fatigue, headache, dizziness, shortness of breath, anorexia, nausea and vomiting. Signs that they were liable to heat stroke were: flushing of the face, a rapid

pulse of 140 to 220, a lack of co-ordinated effort, staring glazed eyes, mental disturbances, poor judgment, fever over 103<sup>o</sup> F., and finally, collapse.

Of special interest is the marked flushing of the face and neck and upper part of the chest which tended to occur in all the men when they first commenced to work in the excess heat. This disappeared after the men became accustomed to the heat. At times it was also noted that there was an engorgement of the conjunctival and scleral vessels and the eyes looked as if they were bloodshot. Machle states that some men tend to develop a case of sniffles which is probably associated with an engorgement of the mucous membranes of the nose.

Wolkin, Goodman, and Kelly (88), in their discussion of the failure of the sweat mechanism in the desert, consider this condition entirely different from heat exhaustion and heat stroke. They observed in the cases which they studied that the symptoms the men presented did not conform clinically with either heat stroke or heat exhaustion. In general, they all presented a typical history; viz., a rather sudden onset of generalized weakness, a subjective

warmth and discomfort, dizziness, an "all in feeling", headache and shakiness. The symptoms occurred during exposure to sunlight, either with or without exertion. The onset of these symptoms was associated with or preceded by a cessation of sweating in each case. This loss of sweating was limited uniformly to the body region below the neck.

The objective findings were characterized most of all by a warm, dry skin from the neck down, whereas all the face and neck showed profuse droplets of sweat. The skin of the entire body below the level of the neck had the appearance of goose flesh. In cases of long standing, there was a fine branny desquamation. However, the body temperature remained, for the most part, below 99° F.

The authors found that such cases might be mistaken for heat stroke, especially if seen during the transient periods of unconsciousness. Furthermore, the dry hot skin universally present in heat stroke might be confusing. The similarity, however, ends here, for the well known hyperpyrexia, coma, elevated pulse and increased respiratory rate of heat stroke are conspicuously absent in the group of cases

discussed. The treatment is the immediate removal from the heat. Salt is not indicated in these cases.

Withington (87), in his series of cases, found that the highest temperature recorded in any patient was 111.5° F. by rectum. The highest temperature at which a patient survived was 109.5° F., although Shutt (73) mentions a case in which the temperature reached 112° F. and the patient lived.

Dry skin is a physical characteristic which is mentioned by many authors (2, 7, 18, 24, 33, 36, 37, 48, 60, 61, 66). Hearne (36) claims that he could pick out in the wards all cases in danger from heat stroke by their dry skin.

Hartung (37) states that an attack may develop suddenly. However, the introductory symptoms may be a general depression, headache, malaise, dizziness, loss of appetite, nausea, vomiting, diarrhea, abdominal pain, restlessness, insomnia, great thirst and convulsions. The pulse is rapid and bounding and the temperature is high—105 to 113° F. The victim is unconscious and his skin is very hot.

Hearne (36), who made a study of several hundred cases of heat hyperpyrexia in Mesopotamia,



reported that in every case the skin was very dry and hot. This, he said, indicated suppression of sweating and heat loss by evaporation.

Walker (82), in his series of cases, states that all cases with a high temperature, 107° F. or above, were unconscious, cyanotic and had constant twitchings of the muscles of the face and extremities with repeated general convulsions. The pupils were contracted and the eyes were rolled up into the head. Respirations were very rapid and stertorous, pulse accelerated, poor in quality and usually irregular. The corneal and pupillary reflexes were absent.

Reid (61) also states that the patients are generally unconscious, livid and often cyanotic with a hot dry skin. Often the temperatures ranged from 104 to 110° F. Reid mentions that the more serious cases were frothing at the mouth and a few patients vomited. This type all showed venous engorgement with visible carotid pulsations in the side of the neck and a full bounding pulse, except in the moribund cases where the heart was giving out. Pupils were small, often pinpoint in size, and failed to

react to light. Knee jerks were frequently absent and a large majority showed considerable muscular rigidity.

Carleton (8) claims that the advanced cases of hyperpyrexia usually occur without heat cramps, although there are fibrillary contractions of the muscles. He also mentions petechia of the skin which other authors, except Ferris and Blankenhorn (21), failed to observe.

Several observers (11, 15, 24, 36) report that sweating is typically absent in heat stroke, while others (19, 85) state that sweating occurs.

Ferris and Blankenhorn (21) obtained accurate histories from a series of twenty-four cases. Fourteen patients suddenly collapsed and lost consciousness. Of the fourteen, five had suffered from weakness, nausea and occasional attacks of fainting over a period of two to three days. Five had noticed slight headache or weakness and palpitation of the heart. A history of typical muscle cramp was obtained from only one person. However, a number of the patients had suffered from attacks of abdominal pain which had occurred previous to the onset of the stroke.

The above authors also observed a maculo-papulo rash of the skin in twenty-three cases. This rash was present over the chest, abdomen and back. Eruption was a fiery-red in color and in many cases was purpuric. Many of the more seriously affected patients who entered in a state of coma showed the evidence of a depressed nervous system. Their muscles were flaccid, respirations rapid and deep, tendon reflexes were diminished or absent, and the patients were incontinent of feces.

Gauss and Meyer (24) found that in a number of patients the attacks came on instantaneously. Patients received into the hospital in many instances were in a state of coma. The temperature found in these patients varied from 94 to 114<sup>o</sup> F., and those individuals in which the temperature was above 110<sup>o</sup> F. failed to live very long after entrance into the hospital. Respirations of the comatose patients were usually labored, rapid, shallow and gasping. Some of the patients uttered a respiratory grunt or moan with each inspiration. Coarse mucous rales were heard in large numbers. The rate of respiration varied from 16 to 48 in patients with temperatures up

to 105° F., and from 30 to 60 with temperatures above 105° F. The skin of the patients was commonly hot, dry and cyanotic, but after the temperature fell it became cold and clammy. Nearly all of the patients were unable to control their bowel movements. Many of the patients vomited and a few had hemorrhages from the rectum and also a few had bloody vomitus. After a return of consciousness, their appetite became poor and a few even developed difficulty in swallowing.

Of the 158 patients which Gauss and Meyer (24) studied, 129 were in coma and 58 of the patients died without recovering consciousness. The majority of the patients manifested some form of symptoms which resulted from cerebrospinal excitation. Many of them, 36 out of 125 patients, had generalized convulsions of either tonic or clonic type. When they emerged from the coma, a number of the patients had a marked disturbance of speech and they seemed to comprehend but their spoken answers were inarticulate, guttural, and meaningless sounds. In some individuals, orientation was lost. A few had evidence of hallucinations and delusions.

Sambon (65) divides the symptoms into two stages, primary and comatose. In the preliminary stage, the patient is seized with a severe headache, becomes exhausted, has difficulty in breathing and develops a distressing burning in the eyes which may or may not be associated with vertigo. The skin becomes dry and very hot, and the patient is pale and very thirsty. The pulse is rapid, full and bounding. The respirations are hurried and oppressed. Temperature may rise suddenly to 107° F. and sometimes to 110° F. Vomiting is very common. Stools are watery, colorless and resemble the "rice water" stools of cholera. The skin and breath may have a peculiar "mousy" odor.

In the comatosed stage, the patient soon passes into a stage of coma. Muscles of the face and upper extremities show convulsive twitchings. The reflexes become greatly diminished. Urine grows scanty and is often suppressed. Respirations become embarrassed and may be almost entirely diaphragmatic. In severe cases, the face and entire body become cyanosed. The eyes are fixed and turned upwards, the conjunctiva congested, and the pupils are contracted

and fail to react to light. Action of the heart is rapid and irregular. After a time, the convulsions and vomiting cease, the sphincters which have contracted now relax, and the patient lies motionless in a state of low muttering delirium. The skin retains its burning heat but becomes clammy, and the respirations gradually become slower and more stertorous.

Fantus (19), in his series of cases, emphasizes that pyrexia predominates the picture. However, he declares that the onset may be gradual with mental excitement or it may show depression. There may be extreme dryness of the mouth and skin, along with dizziness and headache and frequent micturation. If the onset is sudden, the patient is struck down with delirium, stupor or coma, and an hyperpyrexia develops with an intensely hot skin. Fantus found in the semicomatose patient that the superficial reflexes are abolished and in the comatose patient all the reflexes are absent.

Manson-Bahr (50) states that heat-hyperpyrexia is usually preceded by a prodromal stage which may develop entirely independent of exposure to the

sun; often it occurs at night. It is characterized by pain in the limbs, vertigo, mental confusion, thirst, anorexia, photophobia, chromatic aberrations of vision, a suppression of sweating, urinary irritability and vomiting. As the condition advances, the patient becomes restless, has delirium and lapses into coma. The temperature rises sharply, up to 110° F. in some cases. The pupils are contracted, the deep reflexes are absent, the patient may have a diarrhea, and the skin emanates a mousy odor. The urine shows red blood corpuscles, albumin and casts.

Manson-Bahr divides heat stroke into three types. First, there is the gastric type, in which gastric symptoms predominate, such as vomiting and epigastric pain. His second classification is the choleraic type. In this type, the onset is sudden and complicated by severe diarrhea. The temperature in these cases rises to 108 or 110° F. In his third group, he places what he calls the true heat hyperpyrexia. Here, nervous symptoms predominate and this group accounts for 70 percent of the cases.

Willcox (86) found that in the coma stage there is practically always incontinence of urine and feces. The knee jerk is almost always absent, and muscular twitchings and convulsions are common. Symptoms are frequently initiated by nervousness, restlessness, vertigo, headache, confusion, convulsions and coma. Willcox mentions a case in which the temperature rose to 113° F. The face is flushed or cyanotic, the pupils are contracted, the pulse becomes rapid, the blood pressure is low and respirations stertorous. The urine decreases in quantity and may contain red blood cells, albumin, indican and casts. The patients tend to become dehydrated and may at this stage contract a secondary infection. In his series of cases, Willcox found that if the patient had a temperature of 109 to 112° F., his chance to survive was only 30 percent. With a temperature below 104° F., fatality was around eight percent.



## DIFFERENTIAL DIAGNOSIS

Although distinct cases of heat cramps, heat exhaustion and heat stroke are not hard to distinguish if a good history is present and the patient shows the typical findings, many cases occur in which it is difficult or impossible to distinguish these conditions from one another. Also, there are many conditions which may render an accurate interpretation of the patient's condition impossible. If the patient is seen in an unconscious condition, it is impossible in many of the cases to obtain an accurate history which would aid in, or make, the diagnosis. Thus one must rely upon certain physical findings to aid him in making a diagnosis.

Shutt (73) states that although the majority of heat stroke cases occur during the warm months, in those exposed directly to the rays of the sun or in those exposed to high temperatures in laundries, boiler rooms, etc., there are many conditions which may be differentiated. In his attempt at differential diagnosis, he considered the various factors; i.e., the pulse, temperature, respiration, nervous system, muscular system and the changes in

the various organs, and he attempts to distinguish between the following:

1. Heat exhaustion
2. Heat stroke
3. Acute alcoholism
4. Severe delirium tremens
5. Febrile delirium, typhoid, pneumonia, etc.
6. Cranial lesions and injuries when seen  
under 24 hours
7. Cranial lesions and injuries seen after 24  
hours
8. Apoplexy
9. Uremia
10. Poisoning
11. Comatose malaria
12. Status epilepticus
13. Hysteria.

The differential diagnosis given by Shutt (73) follows on the next three pages.

PULSE	TEMP.	RESP.	NERVOUS SYSTEM	MUSCULAR SYSTEM	CHANGES IN SPECIAL ORGANS
Weak and rapid.	1/2 to 4° F. below normal.	Shallow or about normal.	Semi- or unconscious asthenia, collapse. Extreme weakness.	Flaccid, quiet.	Visual changes, headache, cold extremities. Skin pale.
Frequent, full and tense.	Above normal and may reach 110° F. or more.	Active and labor-ed.	Sthenic condition, active usually.	Resistive, tense, a tendency to be active, and strength good.	Involuntary defecation may occur. Skin dry, flushed, cyanotic. May or may not have an alcoholic odor.
Usually full and rapid.	May be decreased, normal or increased.	Frequent-ly ster-torous.	Collapse in extreme cases-- can usually be aroused.	Usually tense. In severe cases may be flaccid.	Breath odor. Cyanosis in extreme cases, with flaccidity. Stomach contents and blood test may be diagnostic.
Rapid and variable in strength.	Above normal-- may be high.	Variable.	Hallucinations. Delusions. Can usually be aroused for a moment.	Weak-- signs of illness for several days.	May or may not have an alcoholic odor. General unkempt appearance. Evidence of disease of long duration.

	PULSE	TEMP.	RESP.	NERVOUS SYSTEM	MUSCULAR SYSTEM	CHANGES IN SPECIAL ORGANS
5.	Variable.	Always above normal. Bathing will not lower to normal.	Variable.	Variable. Delirium. Tremors. Carphologia.	Feebly active. Shows signs of an extended illness.	Accumulations around the teeth and gums. Laboratory exam of body fluids. Skin and other physical findings.
6.	Full, shallow. Regular or irregular.	May be subnormal but usually it is above normal.	Variable.	Semi- or unconscious, quiet or delirious. Basal injuries usually produce active delirium. Reflex changes.	May be relaxed or may have a local spasm or paralysis. Usually entire body appears well nourished.	Evidence of wound injury. Hematoma, ecchymosis or bleeding from ear, nose or mouth. Pupil changes. Reflexes.
7.	Variable.	Usually above normal.	Variable.	Semi- or unconscious. May be delirious or quiet. Reflex changes.	May be relaxed or have a local spasm or paralysis.	Pupil changes. Reflexes very important. Ecchymosis, hematoma, bleeding from nose.
8.	Usually full and slow. May be thready or rapid.	Frequently normal.	Variable. Frequently Stertorous.	Semi- or unconscious. Restless or quiet. May be reflex changes.	Local spasm or paralysis. General condition is usually good.	Age of patient and condition of his vessels. Pupil changes.

	PULSE	TEMP.	RESP.	NERVOUS SYSTEM	MUSCULAR SYSTEM	CHANGES IN SPECIAL ORGANS
9.	Usually full, tense and rapid.	Somewhat above normal.	Frequently deep. May find odor of acetone on breath.	Semi- or unconscious. Sometimes may be aroused.	Feebly active or passive. Nutrition may be poor.	Acetone breath odor.
10.	Variable.	Subnormal, normal or above.	Variable.	Seldom delirious. Reflexes usually present.	May be flaccid or spasmodically active.	Traces on skin and mucous membranes. Findings on clothing. Odor of breath. Cyanosis.
11.	Usually rapid and shallow.	Usually above 105° F.	Variable.	May have some delusions.	Usually passive.	Blood examination, spleen. Temperature is not much reduced by bathing.
12.	Usually rapid.	Usually above normal.	Variable.	Reflexes variable.	Frequent or almost continuous spasm. Individual usually well nourished.	Frequent spasm. Cyanosis. Condition changes rapidly.
13.	About normal.	About normal.	Variable.	Reflexes about	Relaxed, normal or spastic.	Sudden mental or mechanical stimulation usually arouses patient to change his attitude and thus make the diagnosis more plain.

Willcox (86) in discussing heat stroke declares that cerebral malaria and cerebrospinal fever, in addition to other causes of unconsciousness with fever, such as pontine hemorrhages, may simulate heat stroke closely.

Manson-Bahr (50) also states that heat stroke may simulate cerebral or pontine hemorrhage. According to him, it must also be distinguished from uremia, diabetic coma, poisoning from alcohol, opium, carbon monoxide or hydrogen sulfide. He claims that to differentiate from cerebral malaria is very difficult at times because the heat hyperpyrexia is more common in malarial individuals. In diagnosis, the enlargement of the spleen, history, and the presence of the parasites in the blood aid considerably. The heat hyperpyrexia is also often mistaken for cerebrospinal fever. Aids in diagnosis in this case are the refractory irregular pupils, the strabismus, Kernig's sign, herpes, and an initial rigor.

## PHYSIOLOGY AND CHEMISTRY

In considering the physiology and chemistry of the effects of heat in man, various factors such as environment, water evaporation from the body, sweating, sodium chloride distribution in the body, blood changes, heat regulating center, and others, must be considered.

According to Ferderber and Moughten (20), the average American who is seated at rest is ideally comfortable at 66° F. effective temperature during the winter season, but in a summer cooled space he would be ideally comfortable at about 72° F. Most individuals seated at rest will maintain temperature equilibrium with profuse perspiration in an effective temperature as high as 89° F. At higher effective temperatures, the body heat equilibrium will not be maintained; in this case, the body temperature will rise and the pulse rate will increase. In a condition in which the temperature reaches 92.5° F. effective temperature, the average person will have a rise of about 1.7° F. in his body temperature, and his pulse rate will increase 48 per minute in a period of three hours.

The above authors state that there are four factors in the atmospheric environment which tend to affect heat loss from the body, and therefore changes the above equilibrium. These are:

1. The temperature of the surrounding air
2. The moisture content of the air
3. Movement of the air
4. Radiation, or transfer between the body and surrounding surfaces.

Roundtree (64), in his discussion of the water balance of the body, states that water constitutes more than 70 percent of protoplasm. This is of the greatest significance to life. In starvation, an animal can lose practically all of its glycogen and fat and half of its body weight and still live; whereas the loss of 10 percent of the water content of the human body results in serious disorders, and a loss of 20 to 22 percent results in death of the person concerned.

According to Roundtree, water regulates heat distribution and dissipation through its mobility and its ideal thermal properties which are: (1) a high specific heat, which favors storage; (2) a



high caloric demand for its evaporation, which permits a rapid elimination of heat; and (3) a high heat conductivity, which provides rapid equilization of heat within the tissues of the body.

Regulating centers in regard to its disposition are the vasoconstrictor center and the vasoconstrictor fibers in the skin, the sweat and sweat glands and nerves, and the respiratory center (4, 64). It is the nervous mechanism that is responsible for the mammal being homeothermic instead of poikilothermic (4).

According to Best and Taylor (4), heat is lost from the body through the following:

1. Radiation, convection and conduction; percent loss = 70
2. Evaporation of water from the lungs, skin; percent loss = 27
3. By raising the inspired air to body temperature; percent loss = 3
4. From urine and feces; percent loss = 1.

The total quantity of heat loss in 24 hours must equal the amount produced; otherwise the body temperature would rise or fall. According to Hardy and

Dubois (35), between 22 and 35° C. the average temperature of the skin lay about midway between the air and that of the internal parts of the body. When the external temperature is lower, the surface layer of the body cools rapidly and the heat elimination greatly exceeds the heat production. Radiation accounts for about 70 percent of the heat loss at 22 to 26° C., but this percentage falls rapidly to zero as the skin and air temperature approach one another. Vaporation dissipates 18 to 30 percent of the heat at lower temperatures but accounts for about 100 percent at a temperature of 35° C. The heat loss by convection remains fairly uniform at about 15 percent until the air temperature rises to 32° C.

Houghten, Ferderber, and Rosenberg (43) find that heat is dissipated from the body in accordance with four defined physical principles: (1) By direct radiation from the clothed body to the surrounding surfaces in view of the body surface. This transfer follows the laws of Stefan-Bollzman. The authors claim that 40 percent of the total heat is dissipated in this manner, in a person at rest; (2) By direct contact, whereby the air coming into contact with the

surfaces of the clothed body takes up heat. This is generally spoken of as convection loss. Physiologically, the body has little control over this heat loss; (3) By air movements; and (4) By evaporation of perspiration from the body and moisture from the respiratory tract. Heat dissipated in this way is equal to the latent heat of vaporization of the moisture and is known as latent heat loss. The authors maintain that heat production remains minimal and equal to the heat loss from approximately sixty to ninety degrees effective temperature.

Laurens (47) states that the heat loss from the human body takes place mainly by the radiation to the surrounding walls and nearby objects, by convection to the surrounding air, and by evaporation of the moisture from the lungs and skin.

Hill (42) states that under ordinary conditions, the loss by evaporation is insignificant. Also, the relative humidity is not directly correlated with the evaporative loss because the body warms up any stationary layer of air in contact with it and saturates it at skin temperature. Hill declares that the important factor is the physiological deficit; that

is, the difference between the amounts of water held in the air at room temperature and when saturated at skin temperature. Sweating will come into play when cooling by radiation, by convection and by insensible perspiration does not suffice to keep the body temperature within normal range.

Various factors affecting loss by the lungs and skin (climatic conditions) are discussed by Roundtree (64). The higher the temperature, the greater the loss of water by evaporation. As the temperature increases, there results an increase in the rate of respiration. In the ordinary man, sweating begins in the neighborhood of 37° C. If the sweating increases in extreme heat, then heat stroke is liable to take place.

Also, more water is given off in dry than moist air. There is an increase of 200 to 300 percent accompanying a decrease of the relative humidity from 69 to 31 percent. Movement of the air is also an important factor in the evaporation of water from the body, according to Roundtree. Effects of foods, fasting, ingestion also play a part due to the specific dynamic reaction. Light exercise in cool weather

has but a very slight influence, but hard work in hot weather increases the loss tremendously. Also, during rest, the average output is 40 grams an hour, while that in sleep is 32 grams an hour.

Wallace (83) claims that the heat production in the body is largely brought about by the oxidative processes in the muscles. The ingestion of food also increases heat production, and the protein because of its specific dynamic action causes greater heat production than does carbohydrate or fat. Wallace states that a high protein diet accompanied by muscular exercise results in a greater than normal amount of heat production.

Zroalenburg (89) declares that the water balance is the most important factor in the regulation of the temperature of the body. This goes on automatically and the loss of water is supplied through the sense of thirst which calls for more water when the supply runs low.

Other investigators, Haldane (31,32), Dill (12), Roundtree (64), Carleton (8), and Kammer (8), believe that in the final analysis, the lowering of the body temperature in excessive heat is dependent upon the

or during muscular work. Insensible perspiration increases gradually with the environmental temperature up to a certain point (critical temperature) between 86 to 90° F., at which point visible sweating will break out.

Dubois (14) declares that inhabitants of hot climates are prepared physiologically for the warmer climate. Inhabitants of northern climates possess two to three million sweat glands, whereas inhabitants of the tropics have about a million more. On the hands, feet and axillae there is a continued slight activity of the glands. However, over the rest of the body the eccrine sweat glands are called into action when needed in order to dissipate the excess heat. The extra number of eccrine glands which people of the tropics have is their safety valve for hot weather.

According to Laurens (47), within a range of temperature referred to as the "comfort zone", or between 73 to 86° F., the regulation of the dissipation of heat is accomplished and controlled chiefly by the sympathetic nervous system through the vasoconstrictor or the vasodilatation of the

peripheral vascular systems of the upper and lower extremities.

The sweat glands are under control of the sympathetic nervous system (4, 47) but these are cholinergic, not adrenergic. The usual stimulus to sweat secretion is a rise in the blood temperature which exerts its effect in two ways, first upon the nervous centers and secondly reflexly by stimulation of the heat receptors in the skin.

Wolkins (88) also shows that the sweat glands are controlled solely by the sympathetic division of the autonomic nervous system and that the sweat gland activity is definitely a cholinergic response. He states that there is no evidence that the face and neck have a thermoregulatory control center distinct from the rest of the body.

Carleton (8) reports that Barbour and Ranson have shown the heat regulating center to be located in the hypothalamus. It is established experimentally that the hypothalamus is the chief center for the integration of the autonomic regulation of the body temperature, heat conservation, heat loss, sweating, vasoconstriction, osmotic pressure and specific

gravity control. It is supposed that as a result of the strain during prolonged exposure to high environmental temperature, some part of the hypothalamus becomes fatigued or impaired. As a result of this, a clinical syndrome, such as heat stroke, occurs, the basis characteristic of which is a loss of stability of the heat center.

Laurens (47) claims that in the brain stem there are centers that co-ordinate the multitude of functions involved in heat regulation. When the centers are aroused, efferent neurons transmit activating impulses from the central nervous system to the various organs of the body, which tends to control the heat production and the heat loss for the restoration of the normal body temperature. When the external temperature rises the blood vessels of the skin dilate by reflex vasomotor action. More blood flows through the skin, thus raising its temperature and hence its heat loss. This rise in temperature is the least in the skin of the forehead and trunk and greatest in the extremities, particularly the feet. If this method of cooling is not sufficient to prevent a rise of body temperature,



the sweat glands are thrown into action. On exposure to cold, a reverse action takes place. The skin vessels constrict and the bloody supply is curtailed in order to conserve body heat. The nearer the temperature of the environment comes to that of the blood, the smaller is the amount of heat which can be lost by radiation and convection. At an air temperature of 98° F., heat loss by these means must cease.

The degree to which the atmosphere is saturated inversely influences the rate of evaporation of water. Sweat which is not evaporated but simply drips from the skin does not increase heat loss. The sweating mechanism for the elimination of heat is badly crippled when the relative humidity is high. Humidity of the air has practically no effect on the loss of heat by convection and until quite high does not affect appreciably the loss of heat by evaporation.

Roth, Horton, and Sheard (63) show that relative humidity plays little part on the skin temperatures of the body. Under conditions of their investigations, the dissipation of heat from the body was

dependent chiefly on the environmental temperature and was little influenced by the relative humidity when the person under test was in the basal metabolic state, lightly clothed and at rest in still air.

Wallace (83) states that if the environmental temperature rises above 86° F. the peripheral dilatation is not adequate and then sweating is the big reserve factor. Sweating results in evaporation on the skin which lowers the body temperature.

In his discussion of physiology of heat, Osborne (58) says that the vascular system plays an important role in the conduction of heat and thus tends to prevent too great a difference in temperature in the different parts of the body. It allows tremendous variations in thermal conductivity to be brought about in such tissues as the subcutaneous fat and probably the dermis, so that these tissues may serve as good insulators on exposure to cold and yet not interfere to any great extent with heat loss under warm conditions.

The rate of penetration of temperature changes is relatively slow; the heat capacity of the tissues

is so high that relatively large quantities of heat have to be transported before the temperature is greatly altered. Temperature limits beyond which the tissues are damaged may be roughly stated. Local baths of  $113^{\circ}$  F. may be employed for short periods without any danger of persistent injury, but if the baths are employed for an hour or more, an edema lasting twelve to twenty-four hours may be noted.

Changes in temperature have a profound effect on the blood. An increase of the surface temperature from 78.8 to 107.6 or  $114.8^{\circ}$  F. increases the flow in the superficial skin vessels. If circulatory changes are present, the injurious influences of heat may be noted at about  $107.6^{\circ}$  F. upon the tissues. Low temperatures which are applied for a short time, unless freezing has taken place, give little evidence of injury. Injury of tissues appears to be due to the crystallization of water. When the blood is warm, the dissociation constants of the acid radicals of the proteins are increased to a much higher extent than is that of carbonic acid. However, if the total carbon dioxide content

is constant and the blood is warmed, the proteins combine with much less base. The carbon dioxide thus freed is added to the free carbonic acid originally present. The acidity is greatly increased and the carbon dioxide tension is raised. These changes are great, causing an acidity comparable to the normal differences between arterial and venous blood. Also, the activity of leucocytes in phagocytosis is greatly modified by the temperature. The maximum velocity is reached at 104° F.

Mills (53) observed that a few degrees of rise or fall from a normal level seriously interferes with the efficient functioning of the body. The vasomotor control of the blood regulates this heat loss. If a sudden need arises, the blood flow through the skin capillaries may be increased as much as thirty times. If this increased flow of blood through the skin proves inadequate, then the sweat glands become active.

The heat control mechanism functions quickly in order to meet sudden changes in heat production. If there is more prolonged changes, the body adapts by an increase or decrease in its own basic rate of

tissue combustion. Thus, external heat that lasts only a few days calls into play only the vasomotor and sweating mechanisms, but if this heat persists for ten to fifteen days, a definite suppression in the tissue conduction rate occurs. This is the chief reason why severe summer heat waves may persist for weeks, but only cause severe prostration and death in the affected population during just the first ten days.

Heart changes are noticeable in heat conditions. The increased burden on the heart is one of the most notable physiological effects of high temperature on unacclimatized man. Shattuck and Hilferty (69) have shown that individuals with heart diseases are more sensitive to heat and that the most common diseases associated with heat deaths are those of the circulatory system. It is thought that the reduced blood volume consequent upon salt loss may account for the high proportion of cases of circulatory failure in heat casualties.

Adolph (1) finds that the peripheral blood vessels are greatly dilated during an exposure to a high temperature and this dilatation continues

level of only two-thirds or one-half of normal. Mild heat usually produces a slight fall in blood pressure. However, if the heat increases, cardiac output increases and the blood pressure tends to rise. In either case, there is some constriction of the central vessels. In the earlier stages of heat disease this central arteriolar constriction, combined with the contraction of blood reservoirs, such as the spleen, is able to maintain the vascular bed within normal limits and to insure an adequate venous return to the heart. In later stages, when sweating occurs and there is also a continued dilatation of all of the vessels in the skin, it is often difficult or impossible to maintain an adequate venous return. Thus, in a warm climate, the maintenance of an erect posture, which tends to cause the blood to accumulate in the dependent lower limbs, may result in an inadequate venous return to the heart, a decreased cardiac output and syncope.

Basett also states that in the earlier stages of warm weather, the blood pressure may be slightly reduced and the cardiac output slightly increased when the subject is lying down. If the subject is

standing, the superficial dilatation of cutaneous vessels favors the pooling of the blood in the lower limbs, so that a reduction of cardiac output normally seen on standing is likely to be exaggerated and the difference in pulse rate between the lying and standing position is likely to be large. Standing tends to become a strain and slight edema of the feet and ankles may be seen. Light work that involves standing may be performed very inefficiently. However, as the individual becomes acclimatized, these disabilities disappear. The blood pressure becomes normal or subnormal and standing becomes less complicated. There is a subnormal reduction in the cardiac output. The entire basis for this, according to Basett, is the fact that the blood pooled in the legs during standing represents a smaller percentage of the total volume.

Ferderber and Houghten (20), as well as Gauss and Meyer (24), found that in heat conditions there was a rise in the leucocyte count. However, Drinker (16) claims that the white blood cells are slightly lowered.

McLain and Montgomery (52) found that the highest individual values and the highest averages for red blood cells, hemoglobin, hematocrit, white blood cell count and specific gravity of the blood and serum occurred among victims of heat cramps. Averages for all these determinations were distinctly higher among cramp victims than among controls.

Among patients with heat exhaustion the averages for red blood cells, hematocrit, specific gravity, etc., were significantly higher than the corresponding control averages. However, in heat retention, blood findings showed no important deviations from the control. Results obtained were as follows:

OBSERVATION	CONTROLS	CRAMPS	EXHAUS- TION	RETEN- TION
R.B.C.--million/cc.	5.23	5.9	5.7	5.00
Hemoglobin--Gms./cc.	14.3	15.5	14.6	14.8
Volume R.B.C.--%	45.7	52.1	48.9	46.7
Color index	1.01	.96	.95	1.07
Volume index	0.99	.99	.99	1.04
Sp. Gr. of the blood	1.055	1.063	1.060	1.057
Sp. Gr. of the serum	1.026	1.031	1.030	1.027

(continued)



OBSERVATION	CONTROLS	CRAMPS	EXHAUS- TION	RETEN- TION
W.B.C.--M/cc.	7.8	11.27	6.85	8.96
Blood sugar--mg/100 cc.	78.6	97.5	63.6	100.0
Serum NaCl mg of Cl/ 100 cc.	381.6	325.3	380.6	406.7
Plasma CO <sub>2</sub> --vol./%	57.8	57.3	41.0	62.7

Talbot and his associates (76) discovered that the hemoglobin showed a 5 percent decrease and that changes from the normal in the constituents of blood are small when adaptations have been made slowly, but showed increases in sudden exposure to heat.

Osborne (58) reports that the activity of leucocytes in the process of phagocytosis is probably greatly modified by temperature and that the maximal velocity is reached at 104° F.

Glickman, Hick, Keeton, and Montgomery (25), in a study of blood volume changes in men exposed to hot environmental conditions, found that the expansion of the plasma volume by the flow of blood from the reservoirs occurs spontaneously with the evaporation of water from the plasma spread out in the capillaries. Thus, as an individual is further

exposed to the hot environment, more water must be taken from the tissues to replace that lost or evaporated from the plasma.

Hearne (36) claims that the cessation of perspiration is probably due to the exhaustion of the sweating mechanism and that the defect is localized in the sweat glands themselves. Even the use of large doses of a diaphoretic is powerless to produce sweating when once suppression has set in.

Sutton (74) points out that when the body temperature rises, there is an increase in the respiratory and nitrogenous activity. This tends to result in an increase of the internal heat of the body. These processes continue until the temperature reaches around 108° F. when, at this time, there may occur sudden unconsciousness, delirium or convulsions. This is probably due to the physical action of heated blood on the specialized brain cells.

In considering the physiology of heat conditions one must also consider the part which is played by the osmotic pressure and the sodium chloride in the process of sweating.

Fishberg and Bierman (22) found the reaction, the osmotic pressure and the volume relationships of the body fluids to be closely dependent on the property of the acid-base equilibrium. They found that due to sweating which occurs in hot weather or vigorous exercise, there was an enormous loss of body fluid which almost equaled the entire blood volume. It is a known fact that miners during work can lose as much as 3,000 cc. of body fluid per hour (22).

Fishberg finds that the base economy factor of the skin will depend on its ability to produce a fluid of a lower pH than the blood plasma, which acts as a carrier of the catabolic products. In cases studied, the sweat was mostly of the exocrine type and of pH 4 to 4.5. When the pH is in this low range, several important changes occur. The acid substances are carried in the plasma for excretion and consist of carbonates, phosphates, sulfates, chlorides, salts of organic acids and proteinate. All of these appear in the sweat except carbonates and proteinate. The skin is impermeable to the protein, while at the low pH, carbonates as such are

practically non-existent. Thus, the carbonates and proteins do not enter into the sweat but remain in the plasma and exert their function in stabilizing the reaction of the blood. The buffer value of sweat is approximately that of a 0.02 N solution of an acid with a  $K = 10^{-4}$ .

The actual stimulus for the secretion of sweat is in dispute. Best and Taylor (4) state that the usual stimulus to sweat secretion is a rise in blood temperature which exerts its effect in two ways: directly upon the nervous centers, and reflexly by stimulation of the heat receptors in the skin. Fishberg and Bierman (22) state that it is possibly the lactic acid which is formed by the heat and exercise which may be the actual substance initiating the sweating mechanism and that the lowered pH is necessary for the proper function of the glands. Other authors back up this lactic acid theory by stating that the blood lactic acid is known to rise after an individual has done severe exercise (12, 21, 33, 55).

Salt requirements tend to vary. Hibbard (40) declares that the kidney tends to control, or guard,

the salt concentration zealously. In hot countries, a man who does heavy exercise excretes from five to eight liters of sweat and requires about twenty-five grams of salt. Sweat, when excreted, is hypotonic. Consequently, when a liter is excreted, there would exist, if it were not for the kidneys, a hypertonic condition in the intracellular fluids. If a liter of sweat is lost, it is the same as losing a liter of an isotonic solution containing eight and one-half grams of salt. Thus, if a man loses five liters per day, he has lost forty-two and one-half grams of salt. If this continues without replacement, he is bound to get out of balance and cramps are sure to develop.

Dill, Jones, Edwards, and Oberg (13) estimate that man's daily intake of sodium chloride is ten to fifteen grams, and ordinarily the urine output is nearly as great. When the sweat glands secrete, they secrete a hypotonic solution containing sodium and potassium chloride and low concentrations of lactic acid, urea and other substances. The above authors claim that if sweating occurs day after day, the concentration of salt in the sweat cannot remain high.

Johnson (45) and Shoudy and Baetyer (72) also showed that the sodium chloride content of the urine per day is about sixteen grams.

Dill, et al (13), states that the mechanism for controlling the salt concentration remains obscure. It is known that the low salt concentration in extreme dry heat is not related to properties of the blood, for no matter how profuse the sweating, as long as sodium chloride is being put out in the urine, the serum chloride level remains within the normal range. The one proved function of sweat is the part it plays in temperature regulation. However, if sweat were free of dissolved electrolytes, there would be no disadvantage to the individual as the lungs and the kidneys are able to control the normal acid-base equilibrium.

Shoudy and Baetyer (72) show that the amount of sodium chloride absorbed in the kidney tubules depends on the concentration of sodium chloride in the blood plasma. Under proper conditions, the sodium chloride in the blood is maintained at a constant level. The normal sodium chloride lost in the urine is about 15 to 16 grams per 24 hours. When this falls

below three grams per day, a dangerous level has been reached. The amount of salt lost in the sweat varies with the individual, the external air temperature and the humidity. The duration of exposure and the degree of acclimatization have some effect. The total volume of sweat produced in a day when working during a high temperature may be as much as 5 to 6 liters in 24 hours. This means a loss of 20 to 25 grams of sodium chloride.

Brodkin (6) states that one of the most striking physiological principles of the body is its ability to maintain the salt content of the blood serum and the interstitial fluids. When salt is lost, the body tends to sacrifice its precious water stores in order to protect its sodium chloride. Conversely, the extensive loss of water is almost invariably associated with considerable salt loss.

Adolph and Fulton (1) say that unless a high salt intake is maintained in conditions where profuse sweating occurs, the body will suffer and serious consequences will occur.

Dill (12) claims that the sweat varies in composition depending upon its rate of production, the

degree of acclimatization and personal idiosyncrasy. The constituents also are affected by the physical activity, degree of exposure to the sun, and the external temperature. In hot weather, the salt loss is high not only because of the large volume of perspiration, but also due to the fact that in hot weather the sodium chloride content of sweat is increased. If the body is deprived of salt, its excretion in the urine drops rapidly.

Laurens (47) also reports that sweat tends to become more concentrated as it becomes more profuse. In other words, the more active the sweat glands become, the less effectively is the chloride ion held back. After several days of exposure to a hot and dry climate, the concentration of the sweat, if the sweating has been the same, is only one-half that at the beginning for the same amount of exercise. Thus, Laurens shows that one of the adaptive processes by which man becomes accustomed to a high temperature consists in part to the diminishing salt content of sweat. After the individual has become accustomed to the climate, the salt loss will be less and the satisfaction of his thirst will tend to



degree of acclimatization and personal idiosyncrasy. The constituents also are affected by the physical activity, degree of exposure to the sun, and the external temperature. In hot weather, the salt loss is high not only because of the large volume of perspiration, but also due to the fact that in hot weather the sodium chloride content of sweat is increased. If the body is deprived of salt, its excretion in the urine drops rapidly.

Laurens (47) also reports that sweat tends to become more concentrated as it becomes more profuse. In other words, the more active the sweat glands become, the less effectively is the chloride ion held back. After several days of exposure to a hot and dry climate, the concentration of the sweat, if the sweating has been the same, is only one-half that at the beginning for the same amount of exercise. Thus, Laurens shows that one of the adaptive processes by which man becomes accustomed to a high temperature consists in part to the diminishing salt content of sweat. After the individual has become accustomed to the climate, the salt loss will be less and the satisfaction of his thirst will tend to

adjust the concentration of his body fluids. However, some individuals remain susceptible to heat cramp because their sweat glands do not hold back salt effectively.

Robinson, et al (62), showed that white men had a higher rate of sweating than negroes and that this was associated with a greater rise in skin and rectal temperature. The negroes also produced sweat, when working, which contained a much lower concentration of chloride than sweat of white men under the same conditions.

Johnson (15) declares that the sodium chloride makes up 0.17 percent of the body weight, expressed as chloride. This does not exist as such in the body fluids but as sodium and chloride ions whose individual concentration may vary independently of each other. Regardless of whichever of these electrolytes are lost, there results a disturbance of osmotic equilibrium. In an attempt to restore this balance, extracellular fluid moves into the cell or is lost from the body. Food supplies the normal intake of 10 to 15 grams a day, and the kidney is largely responsible for regulating the normal output.

Sweat thus becomes an important vehicle of depletion only in the profuse sweating induced by hard physical work at a high temperature.

Hunt (44) states that the organism depends on evaporation as the cooling agent. Each liter of water evaporated tends to neutralize 582 calories. If there is a restriction of sweating, the body temperature rises and the water and salt loss from its storehouses requires a long time to replace.

Carleton (8) declares that the healthy individual attempts to maintain a constant quantity of water and a constant ratio of water to the dissolved substance, which results in a relatively constant osmotic equilibrium.

This equilibrium is shown schematically, as described by Dill (12):

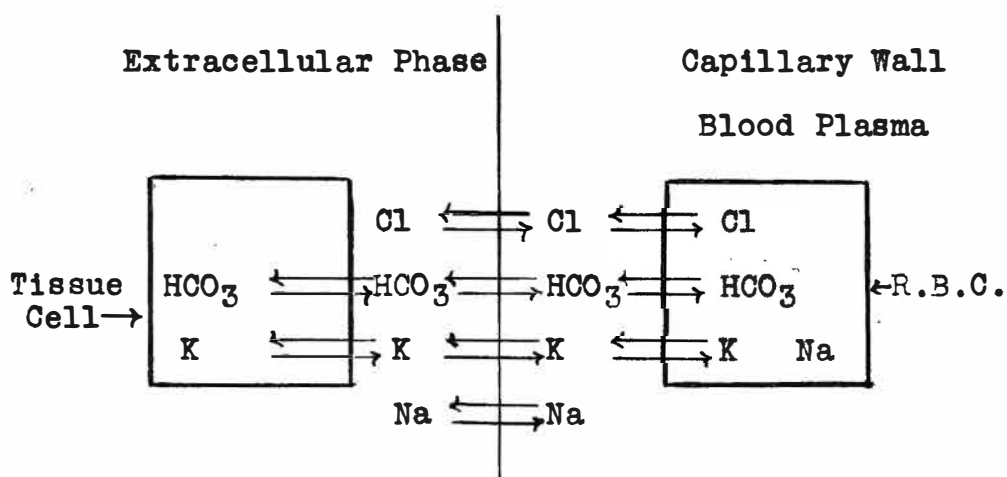

As an explanation of the above, the sodium is present in a low concentration in the human red blood cell. It is absent in the other cells and unable to move across the cell boundaries. However, the potassium can enter and leave muscle cells, but its concentration within cells exceeds that without, and no doubt the ratio of its concentration within to that without tends to remain fairly constant. The chloride is able to pass in and out of the red blood cells, but it does not enter other cells. Also, the bicarbonate is able to freely traverse the red blood cell wall. The capillary wall is freely permeable to all these ions.

Dill believes that it is likely the marked loss of chloride from extracellular fluid plus strenuous muscular activity is in some way responsible for the painful muscular contractions which result in heat cramps.

## PATHOLOGY

Zroalenburg (89) remarks that the "pathology of heat exhaustion is that of dehydration". Morton (55) declares that the pathogenesis appears to be in the nature of an auto-intoxication which is probably due to the failure of the excretory organs to get rid of the products of metabolism. He believes that this may be due to the presence of some substance which is allied to histamine which was produced in the body due to faulty metabolism. The analogy to superficial burns is striking and suggests a similar pathology.

Phelps (59) states that the pathology strongly suggests an auto-intoxication, which is probably due to metabolic products and bears a striking analogy with the phenomenon of fatigue.

Wilcocks (85) found that in the fatal cases of heat stroke there is a marked and early rigor mortis. When this takes place, there is a marked congestion of the viscera; also, there may be petechial hemorrhages into the skin or mucous membrane. In some cases, cloudy swelling of the organs took place.

Samson (65) declares that the chief findings after death are the great congestion of the lungs and

the extreme venous engorgement. At death, the temperature of the body may be about 110° F., but this slowly decreases. Sugillations form quickly and in quantity over the entire body. The post-mortem rigidity which occurs is of short duration, and putrefaction quickly occurs. An effused serum surrounds the brain and cord which is anemic. Ventricles of the brain are often distended with serum and the large venous trunks in the membranes are generally engorged. There is rarely any sign of hemorrhage, but the ganglion cells may exhibit an acute parenchymatous degeneration.

The lungs are hyperemic. They are almost black in color, and the lung tissue is very firm to the touch. However, the lung will still crepitate upon pressure. The bronchi becomes filled with a frothy serous-like fluid.

The left ventricle is contracted and emptied. There is a certain amount of blood in the right chambers which is dark in color. In the pulmonary artery the blood is also dark and only partly coagulated. Venous engorgement is extreme. There is a very peculiar fluidity of the blood. This

passive hyperemia of the brain and lungs, pulmonary edema, a cloudy swelling of the liver, kidneys and the myocardium. Also found in some cases is hyperplasia of the spleen and petechial hemorrhages of various membranes and the skin.

Ferris and Blankenhorn (21), in autopsies performed on twelve patients, showed that the findings were of interest chiefly in that the majority of patients showed evidence of a degenerative vascular disease. Bronchopneumonia was thought to have caused death in two of the cases.

Withington (87) at autopsies found that the lesions which were present were chiefly subendocardial, along with pulmonary edema and hyperemia of the meninges.

McKenzie, et al (51), reporting on the pathology, believed that there is a serous meningitis with heat stroke. They found in their cases extensive edema of the leptomeninges with a varying amount of cells in the transudate. In their examination of thirty-seven persons who died of heat stroke, the following alterations were found quite regularly: there was a marked generalized passive hyperemia,

especially noticeable in the brain and lungs; also a hyperplasia of the spleen, a cloudy swelling of the liver, kidneys and myocardium with petechial hemorrhages of the various mucous membranes and of the skin.

Gauss and Meyer (24), in their cases, also remarked upon the extensive brain and leptomeninges edema which was present.

Hill (41) found in his post-mortems that the organs in a case of heat stroke showed capillary congestion as in wound shock. Zroalenburg (89) enlarged upon this when he noticed that during the later stages of heat hyperpyrexia, there is usually congestion which results in a cyanosis which tends to persist even after death. The skin color of individuals dying from heat stroke assumes a dark color after a few days which makes them look like negroes.

Hall and Wakefield (33) claim that the most important acute pathologic change in major heat stroke, other than that due to the effects of a high temperature upon the tissues per se, is a massive increase in lactic acid which leads to the symptoms of



acidosis. In some cases, the lactic acid increases up to three hundred percent. Pathologic changes seen were rigid contraction of the left heart, venous congestion, contraction of the intestines and urinary bladder, dilatation of the stomach and cloudy swelling and degeneration of the parenchymatous elements, particularly those of the glandular and nervous systems.

Fletcher and Hopkins (23) have shown that in heat rigor, a maximum of lactic acid is produced in the muscles--from 0.3 to 0.5 percent.

Manson-Bahr (50) states that after death with heat stroke, rigor mortis sets in early. He finds that there is a congestion of the venous system and the right side of the heart. The blood and muscles are acid in reaction. The heart is in rigor mortis with a marked contraction of the left ventricle. A venous congestion of the meninges exists, as well as necrotic changes in the ganglion cells of the brain with chromatolysis of nuclei. The spinal fluid pressure is increased. The intestinal mucosa is swollen and greatly congested. After death, the temperature of the cadaver may rise to 114<sup>o</sup> F.

Levick (48) declares that the post-mortem findings and appearance bear a resemblance to typhus fever.

## TREATMENT

In discussing the treatment of the various heat conditions in man, the treatment for the three main conditions, i.e., heat cramps, heat exhaustion, and heat stroke, will be considered. Various authors seem to be quite well agreed upon the mode of treatment which, for the main part, consists in the removal of the patient from the heat, restoration of body fluids, attempt to bring the temperature to normal, and good supportive treatment.

The prophylaxis is important in all the conditions and accord to Fantus (19) must include lessening heat production, increasing heat elimination, and minimizing exposure to the heat.

In the first instance, heat production should be lessened by refraining from undue muscular exercise when the heat is intense. In very hot climates the mid-day siesta is a hygienic necessity. Here, most of the work should be done in the cooler part of the day. Also, foods should be easily digestible and moderate in amounts and consist largely of carbohydrates with avoidance of fats and proteins.

Secondly, the chief defense of the body when it must maintain its normal temperature in spite of an

increase in external heat is by the evaporation of sweat. Thus, the production of sweat should be encouraged. This is done by the frequent ingestion of water. However, as profuse sweating tends to deprive the body of sodium chloride--as much as two to three grams may be lost per hour--the sodium chloride must be replaced. When the production of sweat is not enough, the skin should be kept moist. Sweat cools a person only when it evaporates and this must be favored by the wearing of loose, thin, light and non-constricting clothing or practically no clothing at all and by the exposure to air currents.

Finally, an individual must avoid exposure to the direct rays of the sun, for the visible and the ultra-violet rays are the most dangerous, especially when they fall upon the uncovered head.

Wilcocks (85) points out that the paramount preoccupation of medical officers who work in hot climates is to prevent heat disturbances from taking place in the men under their jurisdiction. Men who are to see duty in hot climates should be physically healthy. Also, Wilcocks considers various factors very necessary in order to prevent heat illness;

these are: ventilation, counter reflection, a mid-day rest, adequate fluid intake, light carbohydrate diet, and suitable clothing.

Ladell, et al (46), advocates that all men exposed to extreme heat should be educated to produce at least thirty ounces of urine per day. They state that a low urine volume is a dangerous thing. For prevention they recommend the daily salt intake of forty-eight grams. This amount is to cover sweating at the rate of seven and one-half liters per day, a urine loss of five grams per day, and a waste of six grams. For control, the urine should be tested for chloride at regular intervals and the absence of or a low chloride in a concentrated urine is an early sign of a salt deficiency. Also, the men concerned should be weighed at fairly regular intervals and if they are losing weight, they should drink more water and take more salt.

Carleton (8) declares that the treatment of any heat sickness must be directed at that portion of the adaptive mechanisms which have failed. According to Carleton, certain general methods benefit all cases; these are: bed rest in a cool room, sponging

of the body surfaces with tepid water, and 500 to 1,000 cc. of chilled normal saline solution by mouth. The sodium chloride solution is of special importance if cramps are present. In severe cases, the individual is usually in shock and must be treated as such. In cases of associated anoxemia, oxygen and carbon dioxide are indicated.

#### 1. Heat Cramps.

In the treatment of heat cramps, the main thing to accomplish is restoration of the lost sodium chloride. According to Schofield (68), the prophylactic use of sodium chloride is very old and even outside the ranks of orthodox medicine. Salted drinking water was supplied to the sailors of British vessels in the Red Sea. They probably adopted the practice from the Arabs who had followed it from time unknown. Schofield states that Christ probably had in mind more than the gustatory effect when He referred to His followers as "Salt of the Earth".

Many authors, Wallace (83); Brodtkin (6); Hibbard (40); Basett (3); Wolkin (88); Van Zwalenburg (80); Derrick (11); Talbot (75); Ladell, Waterlow,

and Hudson (46); Fantus (19); Carleton (8); Collings, Shoudy, and Shaffer (9); Shoudy and Baeyter (72); and others, recommend sodium chloride in prevention and treatment of heat cramps.

Shoudy and Baeyter (72) found that the most efficient method in preventing heat cramps is to replace the salt lost in the sweat by taking extra salt by mouth. They recommended a concentration of 0.1 percent for the workers who were acclimatized, up to 1 percent sodium chloride for those not accustomed to the climate. They advised a compressed tablet of sixteen grains with each eight-ounce glass of water, to be given every three to four hours.

Eaton (17), in his discussion of the treatment and prevention of heat cramps recommends five grams of sodium chloride to the gallon of water. He cites an instance in which several men were suffering from heat cramps and when given this solution they noticed beneficial results. One case in his series had severe abdominal and muscular cramps in his legs. After the use of the solution, the spasmodic contractions were relieved at the end of three hours.

Bock and Dill (5) declare that the prevention of heat cramps requires good daily hygiene, including an adequate amount of sleep and a balanced diet which contains sufficient salt which will produce an output of at least three grams of salt in the daily urine. They recommend an intake of fifteen to twenty grams per day depending upon the amount of sweat. If extra salt was needed, this was supplied by drinking water containing 0.1 to 0.25 percent of sodium chloride.

Wilcocks (85) states that the salt loss may be replaced by giving intravenously in severe cramps a mixture of ninety grams of sodium chloride with four grams of calcium chloride per pint. Haldene (28) and Thrower (79) recommend the drinking of water which contains about 0.25 percent of sodium chloride, whereas Wolkin (88) gives four to six grams daily, orally, in the form of tablets, in addition to the drinking of water which is fortified with salt in a 0.1 percent solution.

Allen (2) states that the sodium chloride requirement of unacclimatized men who are working and who sweat five to eight liters per day is not greater



than thirteen to seventeen grams daily. If there is an increase in salt intake above this level, there is a loss in the urine with no apparent change.

Basett (3) agrees that 0.2 to 0.3 percent solutions is the high limit and says that the higher concentrations of salt are not indicated since such solutions are adequate to replace the loss of salt in the sweat. However, if vomiting occurs, then salt should be replaced intravenously. Hypertonic solutions of saline is contraindicated. If given by mouth, the fluids should be given at room temperature and should not be iced as ice fluids are less readily absorbed.

Morton (55), in observations made while studying men working in tropical countries, recommends a preliminary treatment of glucose. He used a mixture of glucose one ounce and sodium bicarbonate 15 grains in normal saline. Morton claims that one transfusion of this is sufficient and the effects dramatic. Almost immediately upon injection, the vomiting ceases and the muscle cramps disappear. In all of his cases the patient was practically convalescent within forty-eight hours. For a prophylaxis

during hot weather, he recommends a diet high in salt intake. He says that if vegetables are not plentiful, then the individual should ingest small quantities of sodium or potassium citrate added to lemon drinks. Individuals should drink plenty of water and avoid alcoholic drinks. Daily exercise is essential but over-exercise should be avoided.

Talbot and Mickelson (77) recommend the replacement of salt by the intravenous route as this is the most efficient and rapid way to restore an individual suffering from cramps to normal. They found, too, that it was possible to prevent cramps by providing a daily supply of salt greater than that lost in the sweat. They determined this amount by knowing the approximate amount of chloride excreted in twenty-four hours in the urine. In their opinion, less than three grams of salt per day in the urine did not provide for a satisfactory margin of safety. They provided this salt in two ways: (1) By drinking cow's milk which had an average salt concentration of about 0.3 percent; or (2) By drinking salted water with a concentration of 0.25 to 1.0 percent. In conclusion, they state that the

amount of salt necessary to prevent cramps is a function of the individual's susceptibility and can be determined.

Ladell, Waterlow, and Hudson (46) recommend in all cases of heat cramps a liberal amount of fluids by mouth. The amount aimed at was sixteen pints daily. Saline was given intravenously to those who could not retain salt by mouth. The usual amounts given was four to five pints of a 0.9 percent solution in a three-hour period. In some cases, the first 500 cc. given had a concentration of 1.8 percent. Most patients responded rapidly to treatment. When the intravenous saline was used, if nausea and vomiting were present, it stopped immediately and in the matter of a few hours the individual began to look and feel better.

Talbot (75) also recommends glucose intravenously in severe cases, as he claims that the fuel reserve of the workmen is severely taxed during working in a hot atmosphere and needs replenishment, and also the glucose aids in combating any acidosis.

Collings, Shoudy, and Shaffer (9) treated a series of four hundred and thirty-seven cases, of

which fifty-eight percent were heat cramps. In all of their cases, the patient was put to bed. If he was cold, blankets and hot water bottles were used to bring the temperature up to 98.6° F. and prevent further chilling. Then heat in the form of a hot water bottle was applied to the site of the cramp. Then a mixture of one-half teaspoonful of salt plus one teaspoonful of dextrose in a glass of water was given orally, and this was repeated every fifteen to thirty minutes until the symptoms had subsided. In very severe cases, the salt and dextrose solution was given intravenously. In their cases they found that all symptoms were relieved in fifteen to forty-five minutes. Also, it was found that salt and dextrose given together seemed to be much more effective and that when given orally would suffice in all but the most severe cases. Rest in bed was important.

Shoudy and Baetyer (72) emphasize that the treatment depends somewhat on the severity of the cramp. Mild cases will recover if put to bed and covered with blankets and external heat applied. Mild cases were usually given by mouth a mixture of ten grams of sodium chloride and five grams of

dextrose, repeated if necessary. In cases in which the temperature was low, if the patient was not sweating, he was covered with blankets and external heat was applied until his body temperature reached normal and he was sweating freely. In the severe cases, they gave intravenously a five percent glucose in normal saline solution. In most cases 500 to 1,000 cc. was required.

Carleton (8) maintains that the sodium chloride is of the utmost importance, especially if muscle cramps are a part of the heat picture, because so far as is known, heat cramps only subside when the plasma chloride has been restored. This author had some success in the use of enteric-coated tablets of sodium chloride, although he also found that for quick relief of the cramps, the intravenous injection was the most reliable and satisfactory.

## 2. Heat Exhaustion.

The preliminary treatment of heat exhaustion is essentially the same as that of heat cramps. Individuals should be removed from the hot rays of the sun, fluids replenished and supportive treatment given.

Van Zwalenburg (80), who studied cases of heat prostrations and dehydration which occurred at Boulder Dam, found that it was necessary to keep up a supply of table salt with the meals. In severe cases of heat prostrations and dehydration which took place at Boulder Dam, it was also necessary to give intravenous dextrose and salt. Van Zwalenburg showed that in 1931, before preventive measures were instituted, there were seventeen deaths from heat exhaustion at Boulder Dam. In 1932, after measures were instituted, there were no deaths and only seven mild cases of heat exhaustion were seen. In 1933, there were no deaths and only four cases of exhaustion.

Shutt (73) declares that heat exhaustion requires treatment suitable to an asthenic condition; that is, conservation and building up the individual's energy. He recommends that individuals suffering from heat exhaustion be placed in a warm bed and be given hot stimulating drinks, such as hot milk, hot eggnog, bouillons, coffee, etc. If the patient's temperature is subnormal, hot blankets are applied until the temperature reaches normal.

Fantus (19) states that in heat exhaustion cases, there are symptoms of depression of the nervous system and collapse often follows. The temperature is often subnormal or only slightly elevated. Besides removing the patient to a cool place, the fluids must be replenished and the patients should be given some stimulation. Fantus recommends that caffeine and sodium benzoate, from 0.25 to 0.5 gram, be injected subcutaneously every four hours. Also, camphor in oil intramuscularly, or metrazol 1 cc. intravenously, can be used if there is no excitation state. If the body temperature is subnormal, warm baths and hot drinks should be given.

Shoudy and Baeyter (72) conclude that since the condition of heat exhaustion resembles that of shock, treatment should be the same. For mild cases, they use bed rest, heat, saline solutions and dextrose.

Wallace (83) feels that heat exhaustion and sun stroke are not two distinct entities. He believes that the cases vary only in the degree of severity and that the most serious cases are those in which the admission temperature was the highest and the perspiration the least. In his opinion, the severity

of the disorder is in inverse proportion to the ability of sweating and evaporating efficiently.

In a study of military cases, prevention of severe cases was accomplished by adhering to the following: All basic trainees were permitted a one-hour rest after the noon meal. They were given a sufficient supply of drinking water which contained the proper amount of salt, and men drilling and perspiring were permitted all the water they wanted provided they were not too hot or the water too cold.

As a further precaution, the men were advised to/or:

1. Receive an adequate fluid and salt intake  
daily
2. Carry canteens of water at all times
3. Drop out of drilling at the first signs of  
exhaustion
4. Take frequent rest periods while drilling
5. Remove their heavy outer coats and shirts  
< when possible
6. Not march in raincoats in hot weather
7. Refrain from alcoholic beverages.



### 3. Heat Stroke.

Heat hyperpyrexia is the most severe form of heat injury. According to Hearne (36), prevention is easier than treatment. By the earlier recognition of suppressed sweating, the prevention of heat stroke becomes an extremely simple matter. Hearne was able to recognize the onset from one to forty-eight hours before an attack. The individual had a hot dry skin which was typically harsh to touch and a raised body temperature, along with a frequency of micturition. When such an individual was discovered having a temperature of 103° F. with complete suppression of sweating, he was stripped and covered with a wet sheet which prevented a more serious attack.

Wilcocks (85) states that heat stroke often develops with startling rapidity and that immediate and thorough treatment is necessary, and it should be begun at the earliest possible moment. This is necessary because severe damage may be done to the vital organs within a short time. The sooner the temperature is brought down, the greater the chance of recovery. The patient should be removed to a cool place. If this is impossible, he should be stripped and wrapped in a

cool wet sheet and the air kept freely moving over the patient. When the temperature falls to  $102^{\circ}$  F., the patient is then given salines to drink. In the treatment, the pulse must be watched and if feeble, camphor or caffeine may be used to help maintain the circulation. In severe cases in which there is cyanosis with engorgement of the veins of the neck, blood letting is advised. In some cases, lumbar puncture may be useful and artificial respiration may even be necessary. After the temperature has dropped, rest and quiet are essential; the bowels should be kept opened and the diet light. If the individual is susceptible, a transfer to a cooler climate should be made or the return to previous conditions should be prevented.

Gauss and Meyer (24) recommend the following treatment if the individual is brought in or seen with a temperature above  $103^{\circ}$  F.: The patient is immediately placed in a tub of tap water with sufficient water to cover the body except the head, which was supported in a hammock packed with ice. Then vigorous friction is applied to the body and ice is placed in the tub. The temperature is taken rectally and when the temperature has reached  $102^{\circ}$  F., the

patient is removed from the bath and is wrapped in sheets and blankets and put to bed. Generally, a temperature of 102° F. was reached in ten to thirty minutes. When the patient returned to bed, the temperature usually continued to fall to 95 or 97° F. Cardiac stimulants are given freely. If the temperature should drop to subnormal, external heat is applied and if it should rise to above 102° F. again, cold packs and alcohol sponges are used to relower it. For restlessness and convulsions, sedatives such as morphine, chloral hydrate, scopolamine and bromides are used. Often for a while in some severe cases, it may be necessary to employ restraint.

Darrach (10) treated his cases of heat stroke by applying ice to the head first; then gradual application of ice to the rest of the body. Ice was applied freely, being rubbed over the entire body and down the arms and legs. Ice was applied until the surface became cool, the temperature lowered and the pulse diminished in frequency.

Shutt (73) also maintains that a reduction of the body temperature is the first object and that this should be done by utilizing the means to establish

the greatest amount of radiation and absorption of heat from the body. His treatment is essentially the same as that of Gauss and Meyer (24) described above. Shutt also says that frequently it is advisable to suggest a change in occupation or position, since there is less resistance to heat affections after the first attack.

Reid (61) indicates that in the treatment there are four main things to consider: (1) The reduction of the high temperature which is done by means of tub baths and vigorous friction; (2) the restoration of the cardiac action, done by the use of atropine for the pulmonary edema, and by the use of caffeine for a respiratory stimulant; (3) the control of convulsions, if present, by the use of morphine; and (4) the treatment of complications, one of the most important being the catheterization for the retention of urine in patients who are brought in unconscious.

Ladell, et al (46), described twelve cases in which the patients had a rectal temperature of  $107^{\circ}$  F. or more, a dry harsh skin, and showed absence of sweating. Their treatment consisted of reducing the body temperature by means of wet sheets and fanning.

After the temperature was reduced, the patients were then transferred to an air-conditioned ward where the temperature was 80° F. Convalescence was rapid and the sweating in most cases was restored in twelve hours of the onset.

Ferris and Blankenhorn (21), in their treatment of cases of heat stroke, also prefer the use of cold sheets and fans to facilitate evaporation and thus lower the body temperature. By using this method, they reduced the temperature in twenty-five of their patients who had temperatures over 105 to 102° F. in nine to forty minutes. This method proved to be effective in lowering the body temperature rapidly and was not associated with any untoward effects, except in one patient whose temperature fell to 99° F. before he could be removed from the ice bath. The temperature of this patient subsequently fell to 96° F. and he developed circulatory collapse and although the use of hot blankets effectively elevated the temperature, the patient died. After adequate reduction in body temperature, the patients were watched carefully for unusual changes in their body temperature. Fluids averaging sixteen grams per day were given by mouth to

those patients who were sufficiently rational to drink; if they were not rational, fluids were then given intravenously.

Manson-Bahr (50) declares that heat stroke cases which occur in the tropics should be looked upon with suspicion as these may occur simultaneously with malaria. He recommends that in all cases of hyperpyrexia occurring under these circumstances, quinine be injected intravenously. Also, every effort should be made to reduce the temperature. The patient is to be placed upon a wet sheet. If possible, continuous ice sprays with electric fan will tend to aid in lowering the temperature as well as stimulate sweating. In extreme cases, ice water enemata can be used. For cases which showed restlessness or convulsions, bromides and chloral hydrate were used.

Manson-Bahr frowns upon the use of ice being rubbed over the body, as advocated by some (10, 24, 61, 73). He claims that rubbing of ice over the skin obstructs evaporation and is not recommended. In his treatment, a thermometer is kept in the patient's rectum and when the temperature has dropped to 104° F., the application of the cold is discontinued. He claims

that if the treatment is carried beyond this point, the temperature may sink to 91° F. and a dangerous collapse ensue. If collapse does occur, then it is necessary to give stimulants and apply warmth. For cases in which respiration is involved, artificial respiration may be necessary. For cerebral cases, lumbar puncture is required. During the period of convalescence, the patient should be shielded from the heat, as sweating is not restored for three weeks. For further prevention, a return to the hot climate should be prohibited.

Some authors are of the opinion that other factors may aid in the prevention of heat illness. Mills (53) states that a high intake of vitamin B affords some protection against severe heat. He claims that 10 mgm. a day has been found much more effective than salt tablets in warding off the effects of severe heat. However, he recommends that not only the thiamin hydrochloride be increased but that the intake of all the B complex be raised. He states that the optimal requirement for dietary thiamin is twice as high at a temperature of 91° F. than it is at 65° F. However, no other reference was read which substantiated Mills' conclusions.

Henschel (38) made studies which indicated that there was no significant beneficial effect of high ascorbic acid intake on the ability of an individual to perform work in the heat. Daily sweat losses were in the neighborhood of five to eight liters, but the total vitamin C in the sweat was entirely negligible. In groups which received vitamin C., heat exhaustion occurred just as frequent as in those which received no vitamin.

Carleton (8) states that vitamin A is of no value in heat conditions.



## SUMMARY AND CONCLUSIONS

1. It is generally agreed that the heat manifestations in man consists primarily of heat cramps, heat exhaustion and heat stroke. The main predisposing factors to be considered are age of individual, arduous labor, deficient air movement, decreased vitality of the individual, debilitating diseases, alcoholism, diet, and acclimatization.

In general, it is agreed that heat itself, high relative humidity and deficient air movement play a part in all the heat conditions. The main etiologic factor for heat cramps is due to the loss of salt from the body. Heat exhaustion is considered to be due to a failure of the peripheral vascular system, whereas heat stroke is agreed by most observers to be due to a failure or disturbance of the heat regulating mechanism.

2. The symptoms vary somewhat for the three conditions and for heat cramps have been shown to be as follows: painful intermittent cramps of the skeletal muscles, especially those of the calves and flexors of the forearm; abdominal cramps; moderate fever; moderate tachycardia, malaise; headache; fatigue; pallor; dizziness; skin that is cold and clammy; and

there may be vomiting, diarrhea, and mental depression.

With heat exhaustion there is anorexia, weakness of the legs, headache, constipation. The individual presents a picture of shock in which he is pale and has a cool clammy skin. There may be an acute stage of discomfort; temperature is often subnormal; pupils dilated; the pulse rapid, soft and fluttering; and the blood pressure low.

In heat stroke the premonitory symptoms consist of a fullness of the head; a feeling of oppression; occipital headache; throbbing of the temples; vertigo and nausea; the respiration and pulse rapid; weakness and fatigue; dim vision; a dry mouth and intense thirst; contracted pupils; absence of deep reflexes; a suppression of sweating; dry and hot skin; high temperature of 102 to 112° F.; incontinence of feces and urine; flaccid muscles; and unconsciousness.

3. Although the heat conditions are usually easily diagnosed, it is necessary to differentiate heat stroke from the following: acute alcoholism, severe delirium tremens, febrile delirium, cranial lesions, apoplexy, uremia, poisonings, comatose malaria,

hysteria, diabetic coma, and cerebral or pontine hemorrhage.

4. Various conditions influence heat loss from the body and the heat is lost from the body by radiation, convection and conduction principally. Oxidative processes play a part in the heat production of the body. However, the body has a heat regulating center which is under autonomic control and the sweat gland activity is a cholinergic response. The heat center is located in the hypothalamus and plays an important part in regulating the temperature of the body, the heat conservation, heat loss, sweating, vasoconstriction, osmotic pressure, and specific gravity of body fluids.

The vascular system plays an important role in the conduction of heat; relative humidity plays little part. It is thought that the vasomotor control of the blood regulates heat loss. The heat control mechanism functions quickly in order to make changes. Heart changes are noticeable in heat conditions; the peripheral blood vessels are greatly dilated during exposure to heat. However, blood findings vary little from normal.

Sweating plays an important part in heat conditions. This is dependent also upon the salt intake and output which affects the water balance of the body, and a marked loss of chloride from the extracellular fluid accounts for the cramps in heat conditions.

5. The pathology of heat exhaustion is that of dehydration. The pathology also suggests an auto-intoxication. Various findings are seen in cases of heat stroke which are as follows: edema of the brain; a generalized hyperemic condition; pulmonary edema; cloudy swelling of the liver, kidneys and myocardium; petechial hemorrhages; contraction of the left heart; congestion of the meninges; swollen intestinal mucosa; and an increase in lactic acid content of the muscles. The post-mortem findings bear a resemblance to typhus fever and have a striking analogy with the phenomenon of fatigue.

6. The treatment has been fairly well agreed upon. For heat cramps, the therapy lies in the prompt replacement of sodium chloride lost by the body. If cases are severe, intravenous injections of normal saline usually gives prompt relief.

With heat exhaustion, the preliminary treatment is essentially the same as that of heat cramps. The individual may be in a state of shock and should be treated as such. Bed rest, heat, saline solutions and good supportive treatment are necessary.

Heat hyperpyrexia is the most severe form of heat injury. Prevention is easier than treatment. The main thing is to reduce the patient's temperature by utilizing the means to establish the greatest amount of radiation and absorption of heat from the body.

Prophylaxis is very important in all heat injuries and must include the lessening of heat production; increasing the heat elimination and minimizing the exposure to the heat. Vitamins have been found of little value in these conditions.

## BIBLIOGRAPHY

1. Adolph, E. F., and Fulton, W. B.: The Effects of Exposure to High Temperature Upon the Circulation of Man, *Am. J. Physiol.*, 67:573, 1924.
2. Allen, George P. F.: Heat Cramps and Heat Hyperpyrexia, *Brit. M. J.*, 1:1098, June 23, 1928.
3. Basett, H. C.: Heat Effects on Blood Volume and Circulation, *J. A. M. A.*, 111:1841-1845, Nov. 12, 1938.
4. Best and Taylor: *Physiological Basis of Medical Practice*, Third Edition, Williams and Wilkins Co., Baltimore, 1943.
5. Bock, A. V., and Dill, D. B.: Resume of Some Physiological Reactions to High External Temperature, *New England J. Med.*, 209:442-444, Aug. 31, 1933.
6. Brodtkin, H. A.: March Casualties due to Heat Exhaustion; Suggested Cause and Treatment, *Mil. Surg.*, 74:295-297, June, 1934.
7. Cameron, W. H.: A Disorder due to Exposure to Intense Heat, *J. A. M. A.*, 52:1483, 1909.
8. Carleton, E. H., and Kammer, A. B.: Heat Sickness, *Rocky Mt. M. J.*, 40:384-389, June, 1943.
9. Collings, G. H.; Shoudy, L. A.; and Shaffer, F. E.: Clinical Aspects of Heat Disease, *Indust. Med.*, 12:728-730, Nov., 1943.
10. Darrach, B.: Cases of Exhaustion from Heat Treated in the New York Hospital by Stimulation and Ice to the Entire Surface of the Body, *Am. J. M. Sc.*, 37:55-57, Feb., 1858.
11. Derrich, E. H.: Heat Cramps and Uremic Cramps with Special Reference to Treatment, *M. J. Australia*, 2:612, 1934.
2. Dill, D. B.: *Heat Physiological Effects*, Fatigue Lab., Harvard Univ., Cambridge, Harvard Univ. Press, 1938.

13. Dill, D. B.; Jones, B. F.; Edwards, H. T.; and Oberg, S. A.: Salt Economy in Extreme Dry Heat, J. Biol. Chem., 100:755, May, 1933.
14. DuBois, E. F.: Heat Loss from the Human Body, Harvey Society Lectures, 88, 1938-1939.
15. Duncan, A.: Remarks on Some Recent Theories on the Action of Heat in the Tropics, J. Roy. Army Med. Corps, 11:71, 1908.
16. Drinker, C. K.: The Effects of Heat and Humidity Upon the Human Body, J. Indust. Hyg. & Tox., 18:471, 1936.
17. Eaton, W. E.: Treatment and Prevention of Heat Cramps, U.S. Navy Med. Bull., 31:162-164, April, 1933.
18. Edsall, D. L.: A Disorder due to Exposure to Intense Heat, J. A. M. A., 51:1969-1971, Dec. 5, 1908.
19. Fantus, B.: Heat Stroke Therapy of Cook County Hospital, J. A. M. A., 103:990-991, Sept. 29, 1934.
20. Ferderber, M. B., and Houghten, F. C.: Effective Temperature Scale; A Measure of Human Comfort in Environmental Temperature, J. A. M. A., 116:474-477, Feb. 8, 1941.
21. Ferris, E. B., and Blankenhorn, M. A.: Clinical and Chemical Observations on Forty-four Cases, J. Clin. Invest., 17:249-262, May, 1938.
22. Fishberg, E., and Bierman, W. I.: Acid-Base Balance in Sweat, J. Biol. Chem., 97:433, Aug., 1932.
23. Fletcher and Hopkins, Cited by Howell, W. A.: A Textbook of Physiology, Sixth Edition, Philadelphia, W. B. Saunders Co., p. 55, 1915.
24. Gauss, H., and Meyer, K. A.: Heat Stroke, Am. J. M. Sc., 154:554-564, Oct., 1917.

25. Glickman, N.: Hick, F. K.; Keeton, R. W.; and Montgomery, M. M.: Blood Volume Changes in Men Exposed to Hot Environmental Conditions for a Few Hours, Am. J. of Physiol., 134:165-176, Sept., 1941.
26. Glover, D. M.: Heat Cramps in Industry, J. Indust. Hyg. & Tox., 13:347, 1931.
27. Griman, S. T.: Sun and Heat Disease, Virginia M. Monthly, 71:380-381, July, 1944.
28. Haldane, J. S.: Heat Effects, Brit. M. J., 609, Apr. 7, 1928.
29. Haldane, J. S.: Influence of High Air Temperature, J. Hyg., 5:494, Oct., 1905.
30. Haldane, J. S.: Salt Depletion by Sweating, Brit. M. J., 2:469, 1929.
31. Haldane, J. S.: Water Poisoning, Brit. M. J., 1:986, 1923.
32. Haldane, J. S., and Priestly, J. M.: The Regulation of Excretion of Water by the Kidneys, J. Physiol., 1:296-311, July 24, 1916.
33. Hall, W. W., and Wakefield, E. G.: Heat Stroke, J. A. M. A., 89:177, July 16, 1927.
34. Hamilton, C. S.; Basu, D. N.; and Halften, J. Van.: Review of Cases of "Effects of Heat", J. Roy. Army Med. Corps, 55:120-125, Aug., 1930.
35. Hardy, J. D., and Dubois, E. F.: Regulation, Basal Metabolism, Radiation, Convection and Vaporization at Temperature of Twenty-two to Thirty-five Degrees Centigrade, J. Nutrit., 15:477-497, May, 1938.
36. Hearne, K. G.: Hyperpyrexial Heat Stroke, Brit. M. J., 1:516, 1919.
37. Harting, E. F.: Sunstroke, Hygeia, 14:502-504, June, 1936.



38. Heilman, M. W., and Montgomery, E. S.: Heat Disease; A Clinical and Laboratory Study, *J. Indust. Hyg. & Tox.*, 18:651, 1936.
39. Henschel, A.: Vitamin C and Ability to Work in Hot Environments, *Am. J. Trop. Med.*, 24:259-265, July, 1944.
40. Hibbard, R. J. B.: Salt Requirements in Hot Climates, *J. A. M. A.*, 122:1204, Aug. 21, 1943.
41. Hill, L.: The Physiological Aspects of Heat Hyperpyrexia, *Brit. M. J.*, 1:399-401, Mar. 20, 1920.
42. Hill, L.: Ventilation, Sunshine and Clothing, *Lancet*, 2:933-936, Oct. 21, 1933.
43. Houghten, F. C.; Ferderber, M. B.; and Rosenberg, A. A.: Physiological Effects of Hot Atmospheres, *Indust. Med: Indust. Hyg. Sect.*, 1:7-17, Jan., 1940.
44. Hunt, E. H.: The Regulation of Body Temperature in Extremes of Dry Heat, *J. Hyg.*, Vol. 12, 4: 479-487, Dec., 1912.
45. Johnson, A. S.: Sodium Chloride Therapy, *New England J. Med.*, 215:438-443, Sept. 3, 1936.
46. Ladell, W. S.: Waterlow; and Hudson, M. F.: Desert Climate; Physiologic and Clinical Observations, *Lancet*, 2:491, Oct. 14, 1944, and p. 527, Oct. 21, 1944.
47. Laurens, H.: Effects of High Temperature on Body Functions: Symposium; Regulation of Body Temperature, *New Orleans M. & Sc. J.*, 93:283-288, Dec., 1940.
48. Levick, J. J.: Remarks on Sunstroke, *Am. J. of Med. Sc.*, 37:40-55, Jan., 1859.
49. Machle, W.: The Physiological Effects of High Temperatures, *Mil. Surg.*, 95:98-105, 1944.
50. Manson-Bahr, P.: Synopsis of Tropical Medicine, The Williams and Wilkins Co., Baltimore, 1943.

51. McKenzie, Pierce, and LeCount, E. R.: Heat Stroke with a Second Study of Cerebral Edema, J. A. M. A., 71:260, 1918.
52. McLain, P. L., and Montgomery, E. S.: Blood of Workmen Exposed to High Temperature, J. Clin. Invest., 17:417-422, July, 1938.
53. Mills, C. A.: Climate and Disease, J. A. M. A., 531, Oct. 31, 1943.
54. Mills, C. A., and Ogle, C. O.: Climatic Basis for Susceptibility to Heat Stroke or Exhaustion, Am. J. Hyg., 17:686-696, May, 1933.
55. Morton, T. C.: Etiology and Treatment of Heat Exhaustion and Heat Hyperpyrexia, Proc. Roy. Soc. Med., 25:1261, 1932.
56. Moss, K. N.: Some Effects of High Air Temperatures and Muscular Exertion upon Colliers, Proc. Roy. Soc., 95:191, 1923-24.
57. Novy, F. G., and Ramsey, J. H.: Failure of the Sweat Mechanism in the Desert in Hot Humid Climates, J. A. M. A., 125:738, July 8, 1944.
58. Osborne, S. L.: Physiology of Heat, Physiotherapy Rev., 19:59-62, Mar.-Apr., 1939.
59. Phelps, I. R.: Heat Cramps and Heat Exhaustion on Board Ships of the Navy in Recent Months, U.S. Navy Med. Bull., 24:148-154, Jan., 1926.
60. Reese, H. H., and Masten, M. G.: Sunstroke, Wisconsin M. J., 30:630-632, Aug., 1931.
61. Reid, W. D.: One Hundred and Fifty-Eight Cases of Heat Prostration at Boston City Hospital July 2nd-13th in 1911, Boston M. & S. J., 165:643-648, Oct. 26, 1911.
62. Robinson, S.; Dill, D. B.; Wilson, J. W.; and Nielson, M.: Adaptations of White Men and Negroes to Prolonged Work in Humid Heat, Am. J. Trop. Med., 21:261-287, Mar., 1941.

63. Roth, G. M.; Horton, B. T.; and Sheard, C.: The Relative Roles of the Extremities in the Dissipation of Heat from the Human Body under Various Environmental Temperatures and Relative Humidities, *Am. J. Physiol.*, 128:782, 1940.
64. Roundtree, L. G.: The Water Balance of the Body, *Physiol. Rev.*, 2:116, Jan., 1922.
65. Sambon, L. W.: Etiology of Heat Stroke, *Brit. Med. J.*, 1:744-748, 1898.
66. Saffert, C. A.: Heat Hyperpyrexia; Report of Extreme Case Surviving for 8½ Days, *Minnesota Med. J.*, 20:106, 1937.
67. Sayer, R. R.: Review of the Literature on the Physiological Effects of Abnormal Temperatures and Humidities, *U.S. Public Health Rep.*, 42: 933-996, Apr. 8, 1927.
68. Schofield, R. O.: Heat Prostration; Treatment at Boulder Dam, California & *West. Med.*, 41:83-86, Aug., 1934.
69. Shattuck, G. C., and Hilferty, M. M.: Causes of Death from Heat in Massachusetts, *New England J. Med.*, 209:319-329, Aug. 17, 1933.
70. Shattuck, G. C., and Hilferty, M. M.: Distribution of Acute Heat Effects in Various Parts of the World, *New England J. Med.*, 214:458, 1936.
71. Shattuck, G. C., and Hilferty, M. M.: Sunstroke and Allied Conditions in the United States, *Am. J. of Trop. Med.*, 12:223-245, May, 1922.
72. Shoudy, L. S., and Baetyer, A. M.: Heat and Muscular Work, *Surg. Gyn. & Obst.*, 62:475-482, Feb., 1936.
73. Shutt, C. H.: Heat Affections, *Interstate Med. J.*, 18:755-761, 1911.
74. Sutton, H.: Influence of High Temperature on the Human Body, *J. Path. & Bact.*, 13:62-63, 1908-09.

75. Talbott, J. H.: Ill Effects of Heat Upon Workmen, J. Indust. Hyg. & Tox., 19:258-274, June, 1937.
76. Talbott, J. H.; Edwards, H. T.; Dill, D. B.; and Drastich: Physiological Response to High Environmental Temperature, Am. J. Trop. Med., 13: 381, 1933.
77. Talbott, J. H., and Mickelson, J.: Heat Cramps; A Clinical and Chemical Study, J. Clin. Invest., 12:533, May, 1933.
78. Taylor, H. L.; Henschel, A.; Mickelson, J.; and Keys, A.: Effects of Sodium Chloride Intake on Work Performance of Man During Exposure to Dry Heat and Experimental Heat Exhaustion, Am. J. Physiol., 140:439-451, Dec., 1943.
79. Thrower, R.: Heat Cramps, Brit. Med. J., pp. 546, Mar. 31, 1928.
80. Van Zwalenburg, C.: Heat Prostration and Dehydration, J. A. M. A., 101:1253, 1933.
81. Wakefield, E. G., and Hall, W. W.: Heat Injuries, J. A. M. A., 89:92, July 9, 1929.
82. Walker, I. C.: Observations on Heat Prostrations, Boston M. & Sc. J., 165:648-650, Oct. 26, 1911.
83. Wallace, A. W.: Heat Exhaustion, Mil. Surg., 93: 140-146, Aug., 1943.
84. Weiner, J. S.: Experimental Studies of Heat Collapse, J. Indust. Hyg. & Tox., 20:389-400, June, 1938.
85. Wilcocks, C.: Heat Stroke and Allied Conditions, Practitioner, 147:463-468, July, 1941.
86. Willcox, W. H.: The Nature and Prevention and Treatment of Heat Hyperpyrexia, Brit. Med. J., 1:392-399, Mar. 20, 1920.
87. Withington, C. F.: Heat Prostration, Boston M. & S. J., 132:511, 1895.

88. Wolkin, J.; Goodman, J. I.; and Kelly, W. E.:  
Failure of the Sweat Mechanism in the Desert;  
Thermogenic Anhidrosis, J. A. M. A., 124:478,  
Feb. 19, 1944.
89. Zroalenburg, C. Van: Dehydration in Heat Exhaustion, California and West. Med., 38:354-358, May, 1933.
90. Yaglon, C. P.: Work Tests Conducted in Atmospheres of Low Temperatures in Still and Moving Air, J. Indust. Hyg., 1:290, 1926.