

AperTO - Archivio Istituzionale Open Access dell'Università di Torino

The fate of nitrogen upon nitrite irradiation: Formation of dissolved vs. gas-phase species

This is the author's manuscript

Original Citation:

Availability:

This version is available <http://hdl.handle.net/2318/1542699> since 2016-10-06T13:23:44Z

Published version:

DOI:10.1016/j.jphotochem.2015.04.005

Terms of use:

Open Access

Anyone can freely access the full text of works made available as "Open Access". Works made available under a Creative Commons license can be used according to the terms and conditions of said license. Use of all other works requires consent of the right holder (author or publisher) if not exempted from copyright protection by the applicable law.

(Article begins on next page)



UNIVERSITÀ DEGLI STUDI DI TORINO

This Accepted Author Manuscript (AAM) is copyrighted and published by Elsevier. It is posted here by agreement between Elsevier and the University of Turin. Changes resulting from the publishing process - such as editing, corrections, structural formatting, and other quality control mechanisms - may not be reflected in this version of the text. The definitive version of the text was subsequently published in

Journal of Photochemistry and Photobiology A: Chemistry, 307, 2015, 30-34.

DOI: 10.1016/j.jphotochem.2015.04.005

You may download, copy and otherwise use the AAM for non-commercial purposes provided that your license is limited by the following restrictions:

- (1) You may use this AAM for non-commercial purposes only under the terms of the CC-BY-NC-ND license.
- (2) The integrity of the work and identification of the author, copyright owner, and publisher must be preserved in any copy.
- (3) You must attribute this AAM in the following format: *Creative Commons BY-NC-ND license* (<http://creativecommons.org/licenses/by-nc-nd/4.0/deed.en>),

<http://www.sciencedirect.com/science/article/pii/S1010603015001185>

The fate of nitrogen upon nitrite irradiation: Formation of dissolved vs. gas-phase species

Elisa De Laurentiis,^a Marco Minella,^a Silvia Berto,^a Valter Maurino,^a Claudio Minero,^a and Davide Vione^{a,b,*}

^a *Università degli Studi di Torino, Dipartimento di Chimica, Via P. Giuria 5, 10125 Torino, Italy. <http://www.chimicadellambiente.unito.it>*

^b *Università degli Studi di Torino, Centro Interdipartimentale NatRisk, Via L. Da Vinci 44, 10095 Grugliasco (TO), Italy. <http://www.natrisk.org>*

* Corresponding author. Fax: +39-011-6705242. E-mail: davide.vione@unito.it.

Abstract

Nitrite photochemical transformation is an important sink for nitrite and a source of nitric oxide, which affects the air-water partitioning of $\bullet\text{NO}$. It is shown here that aliphatic and aromatic $\bullet\text{OH}$ scavengers alter the photochemical fate of nitrogen, in addition to enhancing nitrite photodegradation. In aerated solution, the addition of phenol as scavenger induced a significant formation of gas-phase nitrogen species from irradiated nitrite, differently from nitrite alone or in the presence of 2-propanol. Moreover, phenol strongly favoured the photochemical production of gas-phase nitric oxide in aerated solution: an upper limit of about 20% could be established for the nitrite fraction that may be transformed into gas-phase $\bullet\text{NO}$ under these conditions. The photochemical production of $\bullet\text{NO}$ was considerably higher in the absence of oxygen, most likely because the scavenging of nitric oxide by superoxide is an important $\bullet\text{NO}$ sink in aerated systems. These results suggest that the concentration of dissolved oxygen and the nature of the $\bullet\text{OH}$ scavenger(s) may considerably affect the phototransformation of nitrite into gas-phase nitrogen compounds, and particularly into nitric oxide, in aqueous solution and at water-air interfaces.

Keywords: Nitrite photolysis; Nitrogen biogeochemical cycle; Nitrogen oxides; Hydroxyl radicals; Environmental photochemistry.

1. Introduction

The nitrite ion is the least stable but also the most biologically and photochemically active inorganic nitrogen species that can be found in natural waters. From a photochemical point of view, nitrite photolysis is an important source of hydroxyl radicals ($\bullet\text{OH}$) that are involved in the transformation of xenobiotics and in the mineralisation of natural organic compounds. Nitrite reaches low concentration values in most surface-water environments and, in oxygenated waters, it is quickly converted to NO_3^- [1]. However, the low $[\text{NO}_2^-]$ is compensated for by the ability of nitrite to absorb a significant fraction of sunlight (the UVA absorption maximum of nitrite is around 360 nm) and by the rather elevated photolysis quantum yield [2,3]. Because of its significant photochemical reactivity, nitrite undergoes photodegradation as an important sink in sunlit surface waters [4].

Unlike most other dissolved compounds, the photodegradation of nitrite is enhanced in the presence of $\bullet\text{OH}$ scavengers. When nitrite is alone in solution, the photochemical production of $\bullet\text{OH}$ and the subsequent oxidation of NO_2^- by the hydroxyl radical has the effect of triggering the null cycle (1), which regenerates nitrite with no resulting transformation [2].

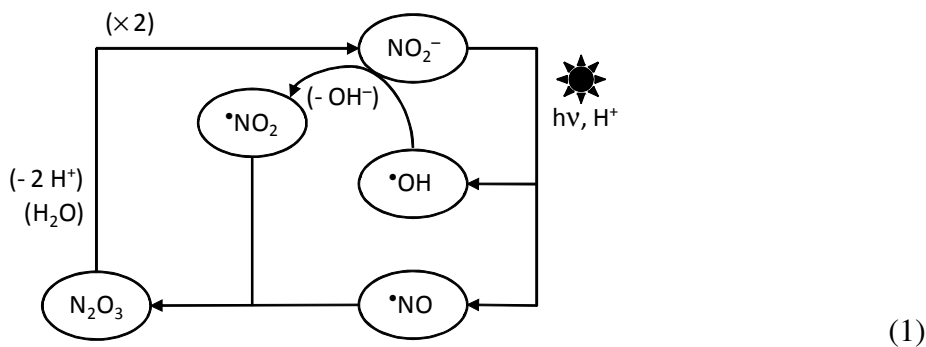

Some photodegradation of nitrite actually takes place, because of the following process [5]:

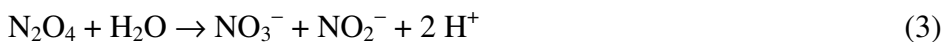

The photodegradation of nitrite is enhanced in the presence of $\bullet\text{OH}$ scavengers, which inhibit the oxidation of nitrite to $\bullet\text{NO}_2$ and limit the onset of the null cycle, triggered by reaction between $\bullet\text{NO}$ and $\bullet\text{NO}_2$ to yield N_2O_3 [4]. The $\bullet\text{OH}$ scavengers would understandably enhance the occurrence of $\bullet\text{NO}$, which could either react to produce dissolved species or be partitioned to the gas phase. In support of the latter issue, irradiation of nitrite in seawater has been reported to produce $\bullet\text{NO}$ and to affect as a consequence its air-water partitioning [6,7]. Interestingly, the photochemical formation of nitric oxide from nitrite seems to be poorly affected by inorganic salts, while there is evidence that reactive oxygen species (and most notably $\text{O}_2^{\bullet-}$) would be important $\bullet\text{NO}$ sinks [7]. The above

discussion suggests that $\bullet\text{OH}$ scavengers could be involved in the formation of $\bullet\text{NO}$, but to our knowledge this issue has not been investigated [7].

Several factors that link nitrite photochemistry with nitric oxide photogeneration are still unclear, including: (i) the effect of $\bullet\text{OH}$ scavengers on the generation of gas-phase nitric oxide, and (ii) the effect of the scavengers on the fraction of nitrite that is transformed into different nitrogen species. The present paper has the purpose of providing a preliminary insight into the above knowledge gaps, by closing the balance of dissolved nitrogen upon nitrite photolysis and by assessing the production of gas-phase nitric oxide in the presence of aliphatic (2-propanol) and aromatic (phenol) $\bullet\text{OH}$ scavengers.

2. Experimental

Reagents and materials. KNO_3 (99%), NaNO_2 (>99%), K_2CO_3 (>99%), phenol (>99%), 2-propanol (>99%) and methanesulphonic acid (>99%) were purchased from Sigma Aldrich; zero-grade air was purchased from SIAD (Bergamo, Italy); N_2 (5.0 grade), O_2 (6.0 grade) and Ar (5.5 grade) were purchased from Sapio (Monza, Italy). Water used was of Milli-Q quality.

Irradiation experiments in solution. A first series of experiments was carried out to assess the fate of dissolved nitrogen upon nitrite irradiation, using the measurement of total dissolved nitrogen (the most important analytical parameter in this context) as a tool to quantify the possible transfer of nitrogen-containing species (including $\bullet\text{NO}$) into the gas phase. The experimental set-up, and particularly the initial concentration of nitrite, was optimised to ensure a suitable measurement of total nitrogen, with the goal of minimising the analytical uncertainties. Unfortunately, the need to ensure reliable measures of total nitrogen required the use of nitrite concentration levels (1 mM) that are considerably higher than the environmental ones. The present experimental results give thus insight into photochemical reaction pathways, but the assessment of their environmental significance will require experiments at lower nitrite levels, to be carried out with a different experimental set-up.

Solutions containing 50 mL of 1 mM NaNO_2 (alone or spiked with 10 mM phenol or 50 mM 2-propanol) were placed into square Pyrex bottles (100 mL capacity). The concentration values of phenol and 2-propanol were chosen to ensure that the two compounds prevailed over nitrite as $\bullet\text{OH}$ scavengers and that they scavenged $\bullet\text{OH}$ to a comparable extent [8]. Each bottle was placed with one of its four lateral faces downwards, and irradiated with magnetic stirring under a solar simulator (Solarbox, CO.FO.ME.GRA., Milan, Italy), equipped with a 1500 W Philips xenon lamp and a 320 nm cut-off filter. Lamp radiation was vertically incident over the solutions and the optical path length was 2 cm. The UV irradiance (295-400 nm) reaching the bottles was $30 \pm 2 \text{ W m}^{-2}$, measured with a CO.FO.ME.GRA. (Milan, Italy) power meter. Dark runs were carried out by wrapping the bottles with aluminium foil and by placing them under the lamp with magnetic

stirring. The temperature of the solutions under the lamp was around 30°C, the solution pH was 6.5-7.5.

Total Nitrogen (TN) was measured with a Shimadzu TN-TOC-V_{CSH} Total Nitrogen and Total Organic Carbon Analyser. The Total Inorganic Nitrogen (TIN = NO₂⁻ + NO₃⁻ + NH₄⁺) was determined by ion chromatography with electrochemical suppression. The adopted apparatus was a Dionex 500 ion chromatograph, equipped with GP40 gradient pump, ED40 electrochemical detector and a Rheodyne injector with 100 µL sample loop. Nitrate and nitrite were eluted on a Ion Pac AG9-HC+AS9-HC (guard column + analytical column), with 9 mM K₂CO₃ at 1.0 mL min⁻¹ flow rate. Eluent conductivity was suppressed with an ASRS 300 conductivity suppression unit. The analysis of ammonium was carried out with CG12A+CS12A guard column + column, eluting with 20 mM methanesulphonic acid at 1.0 mL min⁻¹ flow rate and using a CERS 500 conductivity suppression unit. The Total Organic Nitrogen (TON) was determined as TON = TN - TIN.

Assessment of •NO release to the gas phase. The experimental set-up described above was optimised for the measurement of TN, but it was not suitable to determine gas-phase •NO. To the latter purpose it was used a NO/NO_x detector, HORIBA APNA mod. 370, which exploits the chemiluminescence produced during the reaction between •NO and O₃. This apparatus needs a continuous airflow at the inlet, which was obtained by using a flow photoreactor built according to the UNI 11484 norm [9,10]. Inside the reactor, 50 mL of 10 mM NaNO₂ were placed in a Pyrex Petri dish (110 mm diameter), alone or in the presence of 100 mM phenol or 500 mM 2-propanol, irradiating with a Philips 9W/2P BLB lamp (maximum emission at 355 nm, UV irradiance of 30 ± 1 W m⁻²). The temperature of the irradiated solutions was around 28°C. The reactor had an inner mixing flow of 29 m³ h⁻¹. The gas flow through the reactor and to the detector was provided by a mixture of high-purity N₂ and O₂ in a 79:21 ratio (or by high-purity Ar in the runs without oxygen), at a total flow rate of 1000 mL min⁻¹, produced with an Entech 4600A dynamic diluter. In the runs without oxygen, the nitrite-containing solutions were degassed with ultra-pure Ar for at least half an hour before irradiation. A photograph and a pictorial scheme of the reactor are reported in Figure S1 of the Supplementary Material.

The nitrite concentration used here was 10 times higher compared to the previous set of experiments, and it was required to obtain measurable values of the gas-phase •NO. Unfortunately, an initial concentration of 10 mM NaNO₂ would be unsuitable for the monitoring of TN in the previous experimental set-up, in particular as far as possible TN variations within a reasonable irradiation time are concerned. This known inconsistency in experimental conditions (different concentrations, closed vs. flow systems) was taken into account when discussing the results, and coherently only qualitative comparisons were carried out between the two sets of data. Also in this case the irradiation experiments give insight into the photochemical pathways, but the assessment of their environmental significance will require experiments to be carried out at much lower nitrite concentration with a different experimental set-up.

3. Results and Discussion

Figure 1a shows the time trends of the monitored nitrogen species, as a function of the irradiation time in the presence of nitrite alone. For plot readability issues, error bars are only reported for TN. For the other parameters, the repeatability of duplicated experiments was around 5-10%. There was a practically quantitative conversion of nitrite into nitrate, which is coherent with reactions (1-3), and no significant TN variation was detected during irradiation. Note that nitrite would be the only important $\bullet\text{OH}$ scavenger in such a system. Figure 1b shows the corresponding time trends upon addition of 2-propanol as aliphatic $\bullet\text{OH}$ scavenger. Under the studied conditions and given the reported second-order reaction rate constants with the hydroxyl radicals [8], over 90% of $\bullet\text{OH}$ would react with 2-propanol and less than 10% with nitrite, producing $\bullet\text{NO}_2$. A first effect of the addition of the alcohol was the acceleration of nitrite degradation, in agreement with previous results [4]. Figure 1b also shows that nitrate was the main reaction product. Within experimental error (see the error bars superposed to the data points), the TN did not vary significantly upon irradiation. A remarkable issue is the difference between TN and TIN (up to 4 mg N L⁻¹). This difference would not be accounted for by water-dissolved $\bullet\text{NO}$: with an Henry's law constant $k_{\text{H}}^{\bullet\text{NO}} = 1.9 \cdot 10^{-3} \text{ M atm}^{-1}$ [11], $\bullet\text{NO}$ would largely occur in the gas phase. However, if an important fraction of gas-phase $\bullet\text{NO}$ were formed in the irradiated system, one should observe a significant decrease of the TN that represents the total nitrogen occurring in the aqueous phase. Therefore, the TN-TIN difference suggests that an important fraction of nitrogen (almost one-third of TN for an irradiation time of 24-72 h) would occur as dissolved organic compounds. Actually, it is well known that alkyl nitrates (including most notably isopropyl nitrate) are formed upon irradiation of nitrite in the presence of organic compounds [12].

The stability of TN over time in the presence of 2-propanol raises some questions concerning the fate of photogenerated $\bullet\text{NO}$ in the presence of $\bullet\text{OH}$ scavengers. Under these conditions, the null cycle that gives back nitrite would be largely suppressed and an accumulation of $\bullet\text{NO}$ would be expected. In analogy with the results reported for irradiated seawater [7], it can be imagined that $\text{O}_2^{\bullet-}$ could be an important $\bullet\text{NO}$ sink and that it would produce nitrate (see reaction (4)) with elevated reaction rate constant ($(6.7 \pm 0.9) \times 10^9 \text{ L mol}^{-1} \text{ s}^{-1}$ [13]).



Actually, the reactions of alcohols such as 2-propanol with $\bullet\text{OH}$ in aerated solution are well known to produce superoxide in high amount, according to the following processes [5,8]:

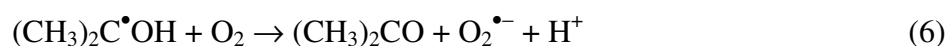

Superoxide could also be formed upon irradiation of nitrite alone (reactions 7,8), but the e^- yield from nitrite photolysis is <8% of the $\bullet\text{OH}$ one [2]. Therefore, the reactions (5,6) that occur upon addition of 2-propanol are expected to be more important sources of $\text{O}_2^{\bullet-}$ compared to reactions (7,8).



Figure 1c reports the time evolution of the nitrogen forms upon nitrite irradiation, by addition of phenol as aromatic $\bullet\text{OH}$ scavenger. Compared to irradiation with 2-propanol, there were interesting similarities and differences. Phenol accelerated the photodegradation of nitrite, too, and nitrate was still the main reaction product. However, as already observed with 2-propanol, the conversion of nitrite into nitrate was not quantitative. Moreover, at high reaction times there was a small but noticeable difference between TN and TIN, which suggests the formation of a small amount of nitrogen-containing organic compounds. Indeed, it is well known that phenol undergoes nitration and nitrosation in the presence of nitrite under irradiation [14-17].

An important peculiarity of the phenol system is that TN was decreased by almost 20% in the first 24 h irradiation, and at the same time nitrite practically disappeared and nitrate reached ~80% of the initial nitrite. The initial decrease of TN, of over 2 mg L⁻¹ in the first 24 h irradiation (see Figure 1c) is statistically significant when considering the relevant error bars, and it suggests that a non-negligible nitrogen fraction escaped from the solution to the gas phase. Interestingly, this result places an upper limit of ~20% for the fraction of nitrite that could be transformed into gas-phase $\bullet\text{NO}$, because one should consider that the gas-phase nitrogen might consist, at least in part, of other volatile compounds. The decrease of TN practically stopped after 24 h irradiation. This event coincided with the disappearance of nitrite and with the occurrence of nitrate as the main dissolved species, which is well known to be less photochemically active than nitrite [5,7]. For irradiation times longer than 24 h there is some indication of a possible increase of TN, although its statistical significance is uncertain. If real, such an effect could be the consequence of a reaction between $\bullet\text{NO}$ and dissolved species that could alter the phase-partitioning equilibrium.

An important difference between nitrite irradiation with 2-propanol and with phenol is the TN stability in the former case, to be compared with the decrease in the latter. This difference can be explained under the hypotheses that (i) the gas-phase nitrogen mainly consists of $\bullet\text{NO}$ and (ii) $\text{O}_2^{\bullet-}$ is the main $\bullet\text{NO}$ sink, preventing its escape to the gas phase. In fact, while the reactions between aromatics and $\bullet\text{OH}$ in aerated solution produce $\text{O}_2^{\bullet-}$, the relevant superoxide yields are lower compared to the case of alcohols such as 2-propanol [18-20].

The results obtained so far suggest that phenol, compared to 2-propanol, might favour the production of gas-phase nitrogen species (such as $\bullet\text{NO}$) from irradiated nitrite. However, the actual occurrence of $\bullet\text{NO}$ in the gas phase was not demonstrated. To do so, a different experimental set-up was used (flow photoreactor coupled to NO_x detector, with higher concentrations of NO_2^- and $\bullet\text{OH}$

scavengers). Figure 2a reports the results obtained with an atmosphere of artificial air. It is shown that no $\bullet\text{NO}$ could be detected before the lamp was turned on. Illumination of the solutions caused the concentration of nitric oxide to increase, and the $\bullet\text{NO}$ level with nitrite + phenol was almost an order of magnitude higher compared to nitrite alone. Furthermore, there was little difference between the irradiation of nitrite + 2-propanol and of nitrite alone. These results are in general agreement with the findings obtained with the TN measures, and they indicate that the formation of gas-phase $\bullet\text{NO}$ was enhanced in the presence of an aromatic $\bullet\text{OH}$ scavenger such as phenol.

Figure 2b reports the results of a comparable experiment carried out in the absence of gas-phase oxygen and with otherwise identical conditions. First of all, the levels of gas-phase $\bullet\text{NO}$ were much higher than in the previous case for all the tested conditions, which is in agreement with the assumption that $\text{O}_2^{\bullet-}$ would be a major scavenger of nitric oxide in the aqueous phase (no $\text{O}_2^{\bullet-}$ formation is expected to take place in the absence of oxygen). It is also suggested that significant amounts of $\text{O}_2^{\bullet-}$ would be formed with oxygen under all circumstances, presumably by reactions (7,8), as well as (5,6) with 2-propanol and corresponding processes with phenol. Also note that the gas-phase levels of $\bullet\text{NO}_2$ were negligible in all cases, which excludes an important transformation process of gaseous $\bullet\text{NO}$ either in the presence or in the absence of O_2 . The second issue is that, without oxygen, the $\bullet\text{NO}$ level was the highest in the presence of 2-propanol. This result suggests an important difference with the data reported for artificial air, and it could make additional evidence that the formation of superoxide would be higher in the presence of 2-propanol compared to phenol.

4. Conclusions

It is shown here that the presence and the kind of the hydroxyl radical scavengers, in addition to enhancing the photochemical degradation of nitrite, also affect the nitrogen fate and, in particular, the occurrence of nitrogen-containing compounds in solution or in the gas phase. Nitrate was in all the cases the main reaction product of nitrite photolysis, and the nitrite-nitrate conversion was practically quantitative upon irradiation of nitrite alone. In the presence of 2-propanol as $\bullet\text{OH}$ scavenger, practically all the nitrogen remained in solution but a significant fraction of N-containing organic compounds was formed. In the presence of phenol, an important part of nitrogen underwent partitioning to the gas phase. Considering that the gas phase could contain both nitric oxide and other compounds, an upper limit of around 20% could be estimated for the fraction of nitrite undergoing phototransformation into gas-phase nitric oxide in the presence of phenol.

Coherently with the above findings, independent experiments showed that phenol favours the production of gas-phase $\bullet\text{NO}$ in aerated systems. Experiments carried out without oxygen also suggested that $\text{O}_2^{\bullet-}$ would be a major $\bullet\text{NO}$ sink. These findings indicate that the amounts of dissolved oxygen and of aromatic vs. aliphatic compounds in dissolved organic matter might affect the transfer of photogenerated nitric oxide from the aqueous solution to the atmosphere. Additional experiments at environmental nitrite concentrations (requiring different experimental set-ups) and

with a wider range of $\bullet\text{OH}$ scavengers are needed to assess the environmental significance of the investigated phenomenon.

Acknowledgements

DV acknowledges financial support by Università di Torino - EU Accelerating Grants, project TO_Call2_2012_0047 (DOMNAMICS). SB acknowledges financial support by Università di Torino – Compagnia di San Paolo (Progetti di ateneo 2011, linea B, area II, project CAVELAB). The CAVELAB project also supported the post-doc fellowship of EDL.

References

- [1] M. Pinardi, M. Bartoli, D. Longhi, P. Viaroli, Net autotrophy in a fluvial lake: the relative role of phytoplankton and floating-leaved macrophytes, *Aquat. Sci.* 73 (2011) 389-403.
- [2] M. Fischer, P. Warneck, Photodecomposition of nitrite and undissociated nitrous acid in aqueous solution, *J. Phys. Chem.* 100 (1996) 18749-18756.
- [3] M. Passananti, F. Temussi, M.R. Iesce, G. Mailhot, M. Brigante, The impact of the hydroxyl radical photochemical sources on the rivastigmine drug transformation in mimic and natural waters, *Wat. Res.* 47 (2013) 5422-5430.
- [4] D. Vione, M. Minella, C. Minero, V. Maurino, P. Picco, A. Marchetto, G. Tartari, Photodegradation of nitrite in lake waters: Role of dissolved organic matter, *Environ. Chem.* 6 (2009) 407-415.
- [5] J. Mack, J. R. Bolton, Photochemistry of nitrite and nitrate in aqueous solution: A review, *J. Photochem. Photobiol. A: Chem.* 128 (1999) 1-13.
- [6] O.C. Zafiriou, M. McFarland, R. H. Bromund, Nitric oxide in seawater, *Science* 207 (1980) 637-639.
- [7] E.F. Olasehinde, K. Takeda, H. Sakugawa, Photochemical production and consumption mechanisms of nitric oxide in seawater, *Environ. Sci. Technol.* 44 (2010) 8403-8408.
- [8] G. V. Buxton, C. L. Greenstock, W. P. Helman, A. B. Ross, Critical review of rate constants for reactions of hydrated electrons, hydrogen-atoms and hydroxyl radicals ($\bullet\text{OH}$, $\text{O}^{\bullet-}$) in aqueous solution, *J. Phys. Chem. Ref. Data* 17 (1988) 513-886.
- [9] UNI 11484:2013 norm: Photocatalysis - Determination of photocatalytic activity by the tangential continuous flow method - Nitric Oxide abatement (2013).
- [10] C. Minero, A. Bedini, M. Minella, On the standardization of the photocatalytic gas/solid tests, *Int. J. Chem. React. Eng.* 11 (2013) 1-16.

- [11] R. Sander, Compilation of Henry's law constants for inorganic and organic species of potential importance in environmental chemistry, <http://www.henrys-law.org/henry-3.0.pdf>, last accessed March 2015.
- [12] E. E. Dahl, E. S. Salzmann, W. J. de Bruyn, The aqueous phase yield of alkyl nitrates from ROO + NO: Implications for photochemical production in seawater, *Geophys. Res. Lett.* 30 (2003) 1271.
- [13] R. E. Huie, S. Padmaja, The reaction of NO with superoxide, *Free Radic. Res. Commun.* 18 (1993) 195-199.
- [14] F. Machado, P. Boule, Photonitration and photonitrosation of phenolic derivatives induced in aqueous solution by excitation of nitrite and nitrate ions, *J. Photochem. Photobiol. A: Chem.* 86 (1995) 73-80.
- [15] D. Vione, V. Maurino, C. Minero, E. Pelizzetti, Aqueous atmospheric chemistry: Formation of 2,4-dinitrophenol upon nitration of 2-nitrophenol and 4-nitrophenol in solution, *Environ. Sci. Technol.* 39 (2005) 7921-7931.
- [16] M.V. Shankar, S. Nelieu, L. Kerhoas, J. Einhorn, Natural sunlight $\text{NO}_3^-/\text{NO}_2^-$ -induced photo-degradation of phenylurea herbicides in water, *Chemosphere* 71 (2008) 1461-1468.
- [17] K.A. Thorn, L.G. Cox, Ultraviolet irradiation effects incorporation of nitrate and nitrite nitrogen into aquatic natural organic matter, *J. Environ. Qual.* 41(2012) 865-881.
- [18] P. Warneck, C. Wurzinger, Product quantum yields for the 305-nm photodecomposition of NO_3^- in aqueous solution, *J. Phys. Chem.* 92 (1988) 6278-6283.
- [19] J. Bonin, I. Janik, D. Janik, D.M. Bartels, Reaction of the hydroxyl radical with phenol in water up to supercritical conditions, *J. Phys. Chem. A* 111 (2007) 1869-1878.
- [20] X. Fang, G. Mark, C. von Sonntag, OH radical formation by ultrasound in aqueous solutions. Part I. The chemistry underlying the terephthalate dosimeter, *Ultrason. Sonochem.* 3 (1996) 57-63.

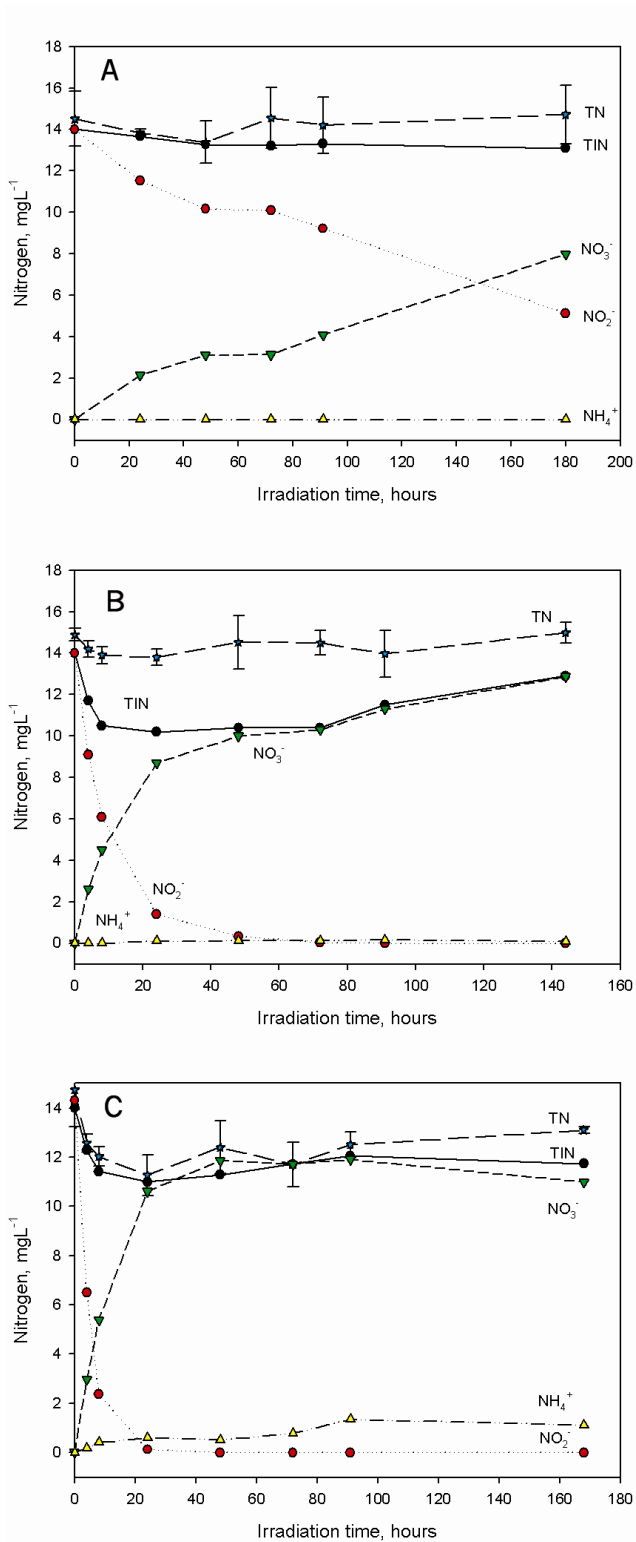

Figure 1. Time trends under simulated sunlight of nitrite, nitrate, ammonium, total inorganic nitrogen (TIN = $\text{NO}_2^- + \text{NO}_3^- + \text{NH}_4^+$) and total nitrogen (TN), upon irradiation of (a) 1 mM NaNO_2 , (b) 1 mM NaNO_2 + 50 mM 2-propanol, and (c) 1 mM NaNO_2 + 10 mM phenol. For plot readability issues, error bars are only reported for TN. For the other parameters, the repeatability of duplicated experiments was around 5-10%.

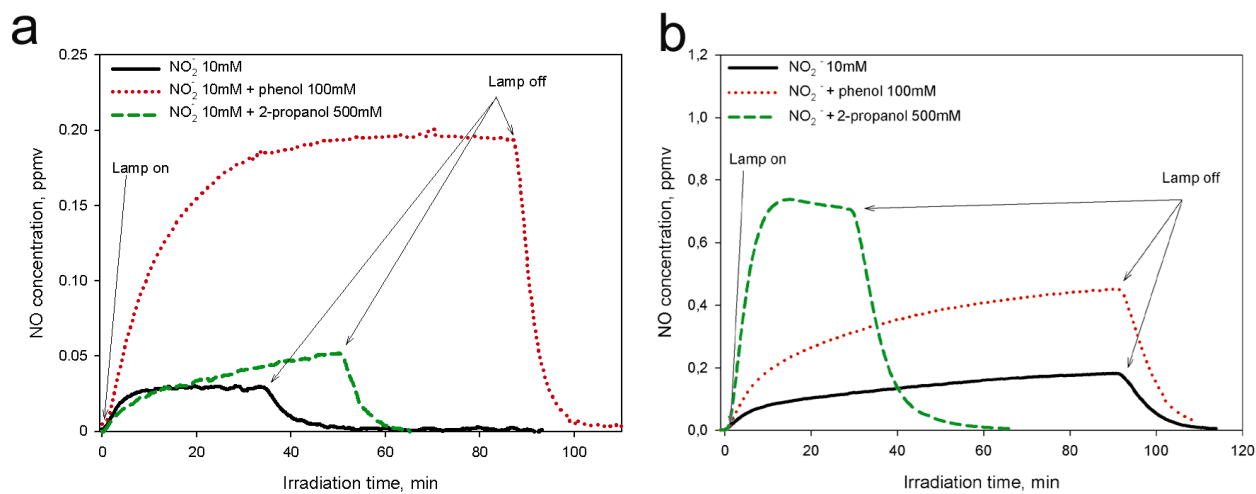

Figure 2. Formation of nitric oxide upon irradiation of 10 mM NaNO₂, alone and in the presence of 100 mM phenol or 500 mM 2-propanol. (a) 79:21 mixture of N₂:O₂; (b) Ar atmosphere, no O₂.